



**Matt Russell, Mayor**  
Garry Wilson, Ward II  
Christopher Updike, Ward III  
Jennifer Mitchell, Ward IV  
  
Eric Franklin, Ward I  
Gerry Pool, Ward II  
Shane Grooms, Ward III  
Jim Deichman, Ward IV

**AGENDA**  
**City Council Meeting**  
**City Council Chambers, 540 Civic Boulevard**  
**October 19, 2021 at 6:00 PM**

**Call Meeting to Order**

**Opening Prayer**

**Pledge of Allegiance to the United States Flag**

**Citizen Participation**

**Consent Agenda**

- [1.](#) Approve October 5, 2021 City Council Minutes.
- [2.](#) As per RSMo. 109.230(4), City records that are on file in the City Clerk’s office and have met the retention schedule will be destroyed in compliance with the guidelines established by the Secretary of State’s office.
- [3.](#) Approve Vendor List.

**Board, Commission, and Committee Schedule**

Board of Adjustment Meeting (Cancelled)	November 4, 2021
City Council Budget Workshop at 5:30	November 4, 2021
Planning & Zoning Meeting	November 8, 2021
City Council Meeting	November 16, 2021
City Council Meeting	November 30, 2021

**Old Business and Tabled Items**

- [4.](#) 21-58 An Ordinance of the City Council of the City of Republic, Missouri, Approving the Final Plat of Olde Savannah Phase Two Subdivision.
- [5.](#) 21-63 An Ordinance of the City Council of the City of Republic, Missouri, Approving the Final Plat of Monte Cristo Phase 10 Subdivision.
- [6.](#) 21-64 An Ordinance of the City Council of the City of Republic, Missouri, Amending Title I, Government Code, Chapter 110, Administrative Policies, Article VIII, Authority to Enter into Contracts Policy and Chapter 120, City Officers and Employees, Article IV, Miscellaneous Provisions.
- [7.](#) 21-65 An Ordinance of the City Council of the City of Republic, Missouri, Authorizing the Execution of an Intergovernmental Agreement with Missouri Department of Social Services Family Support Division Regarding the Low Income Household Water Assistance Program.

**Other Business (Resolutions)**

- [8.](#) 21-R-48 A Resolution of the City Council of the City of Republic, Missouri, Appointing a Council Member for Ward 1.

**Swearing-In of Appointed Official**

### **New Business (First Reading of Ordinances)**

- [9.](#) 21-66 An Ordinance of the City Council of the City of Republic, Missouri, Amending Title IV, Land Use, Chapter 405, Zoning Regulations, Article V, Height and Area Requirements, Exceptions, and Modifications.
- [10.](#) 21-67 An Ordinance of the City Council of the City of Republic, Missouri, Amending Title VI, Business Occupation.

### **Other Business (Resolutions)**

- [11.](#) 21-R-49 A Resolution of the City Council of the City of Republic, Missouri, Approving a Preliminary Plat for Emerald Valley Phase 2, a Residential Subdivision Consisting of Approximately 48 Acres Located in the 1300 Block of North Main Street.
- [12.](#) 21-R-50 A Resolution of the City Council of the City of Republic, Missouri, Authorizing Execution of a Public Donation Agreement Accepting Real Property from Convoy of Hope.
- [13.](#) 21-R-51 A Resolution of the City Council of the City of Republic, Missouri, Authorizing the Execution of a Fourth Amendment to Communication Lease Agreement with New Cingular Wireless PCS, LLC.

### **Reports from Staff**

**Executive Session:** *No further action, other than announcing adjournment by the Mayor, shall take place after an Executive Session that is scheduled as the last matter on the Agenda unless otherwise stated on the Agenda or as allowed per RSMo. 610.02.*

1. RSMo 610.021.1 Pending and/or potential litigation. Closed session. Closed vote. Closed record.
2. RSMo 610.021.2 Real estate acquisition. Closed session. Closed vote. Closed record.
3. RSMo 610.021.3 Hiring, firing, promotion, or disciplining personnel. Closed session. Closed vote. Closed record.

### **Adjournment**

Individuals addressing the Council are asked to step to the microphone and clearly state their name and address before speaking. In accordance with ADA guidelines, if you need special accommodations to attend any city meeting, please notify the City Clerk's Office at 732-3101 at least three days prior to the scheduled meeting. **All meetings are tape recorded for public viewing.**



**REPUBLIC**  
MISSOURI

## MINUTES

**City Council Meeting**  
**City Council Chambers, 540 Civic Boulevard**  
**October 05, 2021 at 6:00 PM**

**Matt Russell, Mayor**  
Garry Wilson, Ward II  
Christopher Updike, Ward III  
Jennifer Mitchell, Ward IV

Eric Franklin, Ward I  
Gerry Pool, Ward II  
Shane Grooms, Ward III  
Jim Deichman, Ward IV

### Call Meeting to Order

The regular session meeting of the City Council of the City of Republic, Greene County, Missouri, was called to order by Mayor Matt Russell at 6:00 p.m. Council Members present included Christopher Updike, Eric Franklin, Garry Wilson, Gerry Pool, Shane Grooms, and Jennifer Mitchell. Others in attendance were: City Administrator David Cameron, Interim City Attorney Damon Phillips, Assistant City Administrator/Parks and Recreation Director Jared Keeling, Information Systems Director Chris Crosby, Police Chief Brian Sells, Planning Manager Karen Haynes, Fire Chief Duane Compton, Chief of Staff Lisa Addington, BUILDS Administrator Andrew Nelson, Public Information Officer Allyssa Dudley, Finance Director Meghin Cook, and City Clerk Laura Burbridge.

### Opening Prayer

Opening prayer was led by City Administrator David Cameron.

### Pledge of Allegiance to the United States Flag

The Pledge of Allegiance was led by Mayor Matt Russell.

### Citizen Participation

Mayor Matt Russell opened citizen participation at 6:01 p.m. State Representative Bishop Davidson presented a Resolution to the Mayor for the 150th Anniversary of the City of Republic.

Ralph Belitz, 1466 S Natchez, spoke regarding the need for a noise ordinance regarding early morning yard or construction work. Mr. Belitz also shared his street needs a speed limit sign due to speeding issues. Mayor Russell closed citizen participation at 6:12 p.m.

### Consent Agenda

Motion was made by Council Member Pool and seconded by Council Member Franklin to approve the consent agenda. The vote was 6 Aye-Franklin, Grooms, Pool, Wilson, Updike, and Mitchell. 0 Nay. Motion Carried.

1. Approve September 21, 2021, City Council Minutes.
2. 21-R-43 A Resolution of the City Council of the City of Republic, Missouri, Approving and Authorizing the City Administrator to Submit a Renewal Application for Hall Provider of Bingo Premises.
3. 21-R-44 A Resolution of the City Council of the City of Republic, Missouri, Approving the 2022 City Council and Other 2022 Meeting Dates.
4. 21-R-45 A Resolution of the City Council of the City of Republic, Missouri, Authorizing the City Administrator to Continue Engaging Outside Legal Counsel Regarding Environmental Compliance Matters.

### Board, Commission, and Committee Schedule

Board of Adjustment Meeting	October 7, 2021 (Cancelled)
Planning & Zoning Meeting	October 12, 2021

City Council Meeting	October 19, 2021
City Council Budget Workshop	October 26, 2021
City Council Meeting	November 2, 2021

City Clerk Laura Burbridge provided updated dates. The Budget Workshop has been moved to November 4<sup>th</sup>. The November 2<sup>nd</sup> meeting was moved to November 30<sup>th</sup>.

### Old Business and Tabled Items

**5. 21-58 An Ordinance of the City Council of the City of Republic, Missouri, Approving the Final Plat of Olde Savannah Phase Two Subdivision.**

Staff notified Council that Bill 21-58 needed to be tabled until October 19th. Council Member Grooms motioned to table the meeting until October 19, 2021. Council Member Wilson seconded. The vote was 6 Aye-Franklin, Grooms, Mitchell, Pool, Updike, and Wilson. 0 Nay. Motion Carried.

**6. 21-61 An Ordinance of the City Council of the City of Republic, Missouri, Approving Amending the Zoning Code and Official Map by Changing the Classification of Approximately 4.77 Acres from Medium Density Single-Family Residential (R1-M) to General Commercial (C-3), Located at 503 North West Avenue.**

Motion was made by Council Member Mitchell and seconded by Council Member Franklin to have the second reading of Bill 21-61 by title only. The vote was 5 Aye-Franklin, Pool, Wilson, Mitchell, and Updike. 0 Nay. 1 Abstention-Grooms. Motion Carried. Karen Haynes was available to answer any questions from Council. Council Member Updike motioned for the passage of Bill 21-61. Council Member Mitchell seconded. A roll call vote was taken digitally. The vote was 6 Aye-Mitchell, Pool, Wilson, Updike, and Franklin. 0 Nay. 1 Abstention-Grooms. Motion Carried.

**7. 21-62 An Ordinance of the City Council of the City of Republic, Missouri, Approving Entry of an Abatement Order on Consent with the Missouri Department of Natural Resources Regarding Wastewater Treatment and Authorizing the Execution of Same by the Mayor.**

Motion was made by Council Member Franklin and seconded by Council Member Grooms to have the second reading of Bill 21-62 by title only. The vote was 6 Aye-Franklin, Grooms, Pool, Wilson, Mitchell, and Updike. 0 Nay. Motion Carried. Andrew Nelson was available to answer any questions from Council. Council Member Wilson motioned for the passage of Bill 21-62. Council Member Updike seconded. A roll call vote was taken digitally. The vote was 6 Aye-Mitchell, Pool, Wilson, Updike, Franklin, and Grooms. 0 Nay. Motion Carried.

### New Business (First Reading of Ordinances)

**8. 21-63 An Ordinance of the City Council of the City of Republic, Missouri, Approving the Final Plat of the Monte Cristo Phase 10 Subdivision.**

Motion was made by Council Member Grooms and seconded by Council Member Franklin to have the first reading of Bill 21-63 by title only. The vote was 6 Aye-Franklin, Grooms, Mitchell, Pool, Updike, and Wilson. 0 Nay. Motion Carried. Karen Haynes provided an overview of the bill. Gayle Saunders, 631 W. Melody Lane, spoke about concerns that developers are not taking care of the tree required to be planted on each property at development, stating that many of the trees planted in prior phases are no longer living. Mayor Russell reminded Council this is a first read and to get with staff prior to the next meeting with any questions.

9. **21-64 An Ordinance of the City Council of the City of Republic, Missouri, Amending Title I, Government Code, Chapter 110, Administrative Policies, Article VIII, Authority to Enter into Contracts Policy and Chapter 120, City Officers and Employees, Article IV, Miscellaneous Provisions.**

Motion was made by Council Member Grooms and seconded by Council Member Wilson to have the first reading of Bill 21-64 by title only. The vote was 6 Aye-Franklin, Grooms, Mitchell, Pool, Updike, and Wilson. 0 Nay. Motion Carried. Karen Haynes provided an overview of the bill. Mayor Russell reminded Council to get with staff prior to the next meeting with any questions.

10. **21-65 An Ordinance of the City Council of the City of Republic, Missouri, Authorizing the Execution of an Intergovernmental Agreement with Missouri Department of Social Services Family Support Division Regarding the Low Income Household Water Assistance Program.**

Motion was made by Council Member Grooms and seconded by Council Member Updike to have the first reading of Bill 21-65 by title only. The vote was 6 Aye-Franklin, Grooms, Mitchell, Pool, Updike, and Wilson. 0 Nay. Motion Carried. Meghan Cook provided an overview of the bill. Mayor Russell reminded Council to get with staff prior to the next meeting with any questions.

#### Other Business (Resolutions)

11. **21-R-46 A Resolution of the City Council of the City of Republic, Missouri, Authorizing the Police and Fire Departments to Utilize Cares Act Reimbursement Funds Allocated by Greene County, Missouri.**

Motion was made by Council Member Franklin and seconded by Council Member Updike to approve Resolution 21-R-46. Police Chief Brian Sells provided an overview of the Resolution. The vote was 6 Aye-Franklin, Grooms, Wilson, Pool, Mitchell, and Updike. 0 Nay. Motion Carried.

12. **21-R-47 A Resolution of the City Council of the City of Republic, Missouri, Determining the Intent of the City of Republic, Missouri, to Reimburse Itself for Certain Capital Expenditures in Connection with the Acquisition, Construction, and Equipping of a Public Works Facility.**

Motion was made by Council Member Updike and seconded by Council Member Pool to approve Resolution 21-R-47. Andrew Nelson provided an overview of the Resolution. The vote was 6 Aye-Franklin, Grooms, Wilson, Pool, Mitchell, and Updike. 0 Nay. Motion Carried.

#### Reports from Staff

City Administrator David Cameron noted the invitation provided to Council for the dedication ceremony of the Gateway Sign on Friday at 11:00. Mr. Cameron thanked Jared and Jennafer for their work on the sign and thanked City Utilities for the lease of the land. Mr. Cameron emphasized that we would love to have many people at the dedication ceremony, but there is no parking at the sign. Mr. Cameron shared there will be a shuttle service from the neighboring parking lot to the site. Mr. Cameron shared we are still working on road access. Mr. Cameron thanked the citizens for voting to build this sign and emphasized not to park on the highway.

City Administrator David Cameron shared on November 3<sup>rd</sup>; the Commission is expected to approve a 6-million-dollar allocation for widening MM. Mr. Cameron shared he and Andrew will be there for the vote and shared it is an open hearing in Kansas City. Mr. Cameron reported we are still working on the intergovernmental agreement with Greene County for another 1.5 million dollars of improvements as

well. Mr. Cameron reminded everyone that widening the street from 2 to 5 lanes will involve property acquisition. Mr. Cameron thanked everyone for the work done on this project.

City Administrator David Cameron thanked the Pumpkin Daze Committee for the great job on Pumpkin Daze. The Parks and Recreation Trust Edge pillar of focus was connection and they focused on connecting with different agencies in the community. Mr. Cameron shared the Parks Department partnered with the committee without taking the event from them. Mr. Cameron thanked the committee for their willingness to partner on this and thanked to our team for looking outside ourselves. Mr. Cameron shared it was great to see our banner with their logo and anticipates next year will be bigger and better. Mr. Cameron thanked staff for their vision and shared they are always first class and to the nines. Mr. Cameron shared he presented at the Chamber today about the growth and development of the city and looks forward to presenting to Council in November about the vision of the city in coordination with the budget discussion. Mr. Cameron shared his appreciation to the Chamber for allowing him to present this and thanked Mayor Russell and Council Member Mitchell for attending.

City Administrator David Cameron thanked Karen, Garrett, Jason, and Andrew for their work in Kansas City last week for a 2-day planning meeting on the Wastewater Treatment Plant. Mr. Cameron thanked State Representative Davidson for meeting to discuss fund availability and shared Congressman Long's office also called about it. Mr. Cameron emphasized we work hard to find a solution and the Mayor has been instrumental, possibly needing to go to Jefferson City at a moment's notice. Mr. Cameron acknowledged the fabulous job Public Information Officer Allyssa Dudley did on the presentation. Mr. Cameron shared she has been here 2-3 weeks and made the presentation with less than one hour of face time with him to set this up. Mr. Cameron thanked Allyssa, Chris, and Lisa for their work preparing for it and praised phenomenal result. Mr. Cameron shared he had a great time, despite not remembering much of it, and appreciates the work we and this community are doing.

City Administrator David Cameron shared he and Mayor Russell interviewed four candidates for the Ward 1 position and hope to get back together to discuss this in a few days. Mr. Cameron shared we are a growing city and could have up to 14,000 more people. Mr. Cameron shared we are working to improve the quality of place in Republic. Mr. Cameron thanked Mayor Russell and former Mayor Jeff Ussery for allowing us the tremendous potential to do our jobs. Mr. Cameron shared every time he and Mayor Russell meet, Mayor Russell asks how he can help. Mr. Cameron acknowledged he sees that from each member of Council and appreciates that we are allowed to do our job without interference. Mr. Cameron emphasized alignment starts at the legislative body and culture changes in the community. Mr. Cameron praised the great leadership on this Council, especially for the \$200.00 per month paycheck. Mr. Cameron emphasized it is a labor of love to lead and guide this community. We are trying to address the heavy items but still work on the smaller ones as well. We have 150-200 million dollars of decisions facing the community and Mayor Russell understands this as a business owner.

Council Member Franklin thanked everyone from Pumpkin Daze for the great event. Mr. Franklin shared it was great to see people laughing and having a good time. Mr. Franklin thanked everyone who was involved in the event.

Mayor Matt Russell shared they did interview for the Ward 1 vacancy and had some qualified individuals apply. Mayor Russell shared they will sit down and talk this week and get it worked out. Mayor Russell shared he would like to have a full legislative body again.

### **Adjournment**

Mayor Russell adjourned the meeting at 6:49 p.m.

ATTEST:

\_\_\_\_\_  
Laura Burbridge, City Clerk

\_\_\_\_\_  
Matt Russell, Mayor

DRAFT



# Record Destruction Request

## Form

MISSOURI RETENTION MANUAL CODE	NAME/DATE OF RECORDS TO BE DISPOSED	DATE(S) OF DOCUMENTS	RETENTION TIME NEEDED FOR RECORD
GS 090 Unemployment Insurance Case Files	Unemployment records	1989-1990, 1992-2001, 2003, 2005-2013	2 years after last action
GS 027 Employee Medical Records	Insurance Claims and medical documentation	2001-2013	7 years after separation
GS 064 Training Records	Training Records-training materials	2000	1) Training materials, retain one copy until superseded; 2) Program materials, retain 3 years
GS 043 Drug Testing Records	Drug Test Results	2002, 2005-2010	Retain positive 5 years, retain negative 1 year.
GS 063 Position Description, Classification, and Compensation Records	Wage Surveys	2004, 2007, 2013	3 years after obsolete or superseded
GS 091 Worker's Compensation Case File	Worker's Comp	2005-2010	10 years after closed if action





# Record Destruction Request

## Form

			taken, 3 years if no action
GS 028 Time and Attendance Records	Timesheets	1993-1999, 2001-2002, 2004, 2016-2017	3 years plus audit
GS 033 Wage and Tax Statements	W-2's	2006-2008, 2013-2015	5 years
GS 034 Federal and State Tax Records	1099's, 941's, W-9's, and similar federal and state completed forms.	2013	5 years
GS 062 Employment Recruitment & Selection Records	Postings and unsuccessful applicants.	2017	Retain unsuccessful application and other records 1 year, Announcements 3 years



Vendor	Added	Added User	Deleted	Deleted User
07501 - TNT Inspection Services LLC	09/01/2021	SHERRI WOODS		
07502 - Northwestern University	09/03/2021	SHERRI WOODS		
07503 - Michael Dewayne Wells	09/09/2021	SHERRI WOODS		
07504 - Huntley Tree Service LLC	09/14/2021	SHERRI WOODS		
07505 - GearGrid LLC	09/15/2021	SHERRI WOODS		
07506 - Northstar Construction Management Co Inc	09/17/2021	SHERRI WOODS		
07507 - The Trails At Valley Park LLC	09/17/2021	SHERRI WOODS		
07508 - Imperial LLC	09/23/2021	SHERRI WOODS		
07509 - Delong Plumbing Two Inc	09/23/2021	SHERRI WOODS		
07510 - Sam Richardson	09/23/2021	SHERRI WOODS		
07511 - Josiah Kennard	09/23/2021	SHERRI WOODS		
07512 - Elijah Kennard	09/23/2021	SHERRI WOODS		
07513 - Elisabeth Creech	09/23/2021	SHERRI WOODS		
07517 - Ethan Meyer	09/30/2021	SHERRI WOODS		
07518 - Edward Mark Ellman	10/05/2021	SHERRI WOODS		
07519 - Duane Gerald Lewis	10/05/2021	SHERRI WOODS		
07520 - Richard T Struckhoff	10/05/2021	SHERRI WOODS		
07521 - David J Sharon	10/05/2021	SHERRI WOODS		
07522 - Randall J Swift	10/05/2021	SHERRI WOODS		
07523 - DSPN Media and Consulting LLC	10/05/2021	SHERRI WOODS		
07525 - Joe Machens Ford Lincoln	10/06/2021	SHERRI WOODS		
07526 - Ambitec Inc	10/07/2021	SHERRI WOODS		
07527 - Brittany Garland	10/07/2021	SHERRI WOODS		
07528 - Mattie Wiles	10/07/2021	SHERRI WOODS		
07529 - Megan D Estes	10/07/2021	SHERRI WOODS		
07530 - Brittany Elizabeth Williams	10/07/2021	SHERRI WOODS		
07531 - Kaitlyn Flom	10/07/2021	SHERRI WOODS		
07532 - Jana Henderson	10/08/2021	SHERRI WOODS		
07533 - Miles Thomas	10/08/2021	SHERRI WOODS		
07534 - Bishop Davidson	10/08/2021	SHERRI WOODS		
07535 - Kaleb Stutesmun	10/15/2021	SHERRI WOODS		
07536 - Kelsi Fritts	10/15/2021	SHERRI WOODS		
07537 - Dustin Luttrell	10/15/2021	SHERRI WOODS		
07538 - Cheryl D Dean	10/15/2021	SHERRI WOODS		

**Vendor Count: (34)**



## AGENDA ITEM ANALYSIS

Project/Issue Name: 21-58 An Ordinance of the City Council of the City of Republic, Missouri, Approving the Final Plat of Olde Savannah Phase Two Subdivision.

Submitted By: Karen Haynes, Planning Manager, BUILDS Department

Date: October 19, 2021

### Issue Statement

The City of Republic's BUILDS Department received a Final Plat Application for Olde Savannah Phase Two Subdivision on August 02, 2021.

### Discussion and/or Analysis

The Final Plat of Olde Savannah Phase Two will legally divide approximately four point six-five (4.65) acres of land into nineteen (19) residential lots and includes the dedication of Right-of-Way, Utility, and Stormwater Easements. The Final Plat includes approximately (1050) linear feet of street and (990) linear feet of sidewalk.

The Final Plat of Olde Savannah Phase Two conforms to the Preliminary Plat approved by City Council on May 19, 2020.

City Staff has reviewed the Final Plat and has determined that it substantially conforms to the requirements of the Preliminary Plat, in addition to the requirements of the City Code Chapter 410 Subdivision Regulations, and Article V Major Subdivision-Final Plat.

### Recommended Action

Staff recommends approval of the Olde Savannah Phase Two Final Plat.

BILL NO. 21-58

ORDINANCE NO. 21-

**AN ORDINANCE OF THE CITY COUNCIL OF THE CITY OF REPUBLIC, MISSOURI,  
APPROVING THE FINAL PLAT OF THE OLDE SAVANNAH PHASE 2 SUBDIVISION**

*WHEREAS*, the City of Republic, Missouri, (herein called the "City" or "Republic") is a municipal corporation and Charter City located in Greene County, Missouri, being duly created, organized, and existing under the laws of the State of Missouri; and

*WHEREAS*, the preliminary plat of the Olde Savannah subdivision (herein called "Subdivision") was approved by the Council on May 19, 2020, in Resolution 20-R-11; and

*WHEREAS*, an application for the review and approval of a final plat of the Subdivision was received by the BUILDS Department, after which the BUILDS Department staff caused the review of the final plat document; and

*WHEREAS*, the minimum required public improvements for the subdivision's final plat have been inspected and approved by the BUILDS Department.

***NOW, THEREFORE, BE IT ORDAINED BY THE CITY COUNCIL OF THE CITY OF REPUBLIC, MISSOURI, AS FOLLOWS:***

- Section 1. That all conditions imposed by the Planning and Zoning Commission and the City Council relating to the acceptance and approval of the Subdivision have been met.
- Section 2. That the final plat of the Subdivision, attached hereto and incorporated herein as "Attachment 1", is hereby approved in all respects.
- Section 3. That the approval of the final plat of the Subdivision is contingent upon the same being recorded within sixty days after the approval certificate is signed and sealed under the hand of the City Clerk.
- Section 4. That the sale of lots and construction of structures in the Subdivision shall not commence until the final plat has been recorded.
- Section 5. The whereas clauses are hereby specifically incorporated herein by reference.
- Section 6. The provisions of this Ordinance are severable and if any provision hereof is declared invalid, unconstitutional, or unenforceable, such determination shall not affect the validity of the remainder of this Ordinance.
- Section 7. This Ordinance shall take effect and be in force from and after its passage as provided by law.

BILL NO. 21-58

ORDINANCE NO. 21-

*PASSED AND APPROVED* at a regular meeting of the City Council of the City of Republic, Missouri  
this \_\_\_\_\_ day of \_\_\_\_\_ 2021.

\_\_\_\_\_  
Matt Russell, Mayor

ATTEST:

\_\_\_\_\_  
Laura Burbridge, City Clerk

Approved as to Form: /s/ Michael Tighe for Damon Phillips, City Attorney

Final Passage and Vote:  
\_\_\_\_\_

# SUBD-FNL 21-007: Olde Savannah Phase 2

Item 4.

## Vicinity Map



### Legend

-  Parcels
-  Olde Savannah Ph. 2
-  Sinkhole
-  Floodplain

Parcel Owner: Olde Savannah, LLC  
 Parcel Address: 6300 Block of South Farm Road 89  
 Area: 4.65 Acres  
 Zoning: High Density Single Family Residential (R1-H)  
 Number of Lots: 19

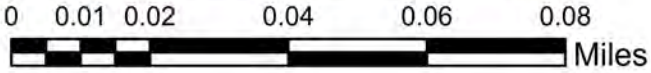

# FINAL PLAT OF OLDE SAVANNAH PHASE 2 A SUBDIVISION IN REPUBLIC, GREENE COUNTY, MISSOURI NW 1/4 OF THE SW 1/4 SECTION 28, TOWNSHIP 28 NORTH, RANGE 23 WEST

SPACE RESERVED FOR GREENE COUNTY RECORDER

- LEGEND**
- EXISTING IRON PIN
  - 5/8" IRON PIN  
(SEMI PERMANENT 5/8"x18" REBAR PLASTIC CAPPED "LC-2007008003")  
(SET AT ALL LOT CORNERS UNLESS OTHERWISE NOTED)
  - PERMANENT MONUMENT SET, 5/8"x24" REBAR WITH  
1 AND 3/4 INCH PLASTIC CAP STAMPED "LC 2007008003"
  - M MEASURED
  - P PLATTED
  - D DEEDED

**OWNER/DEVELOPER**  
OLDE SAVANNAH LLC  
3800 S FREMONT AVE  
SPRINGFIELD MO 65804

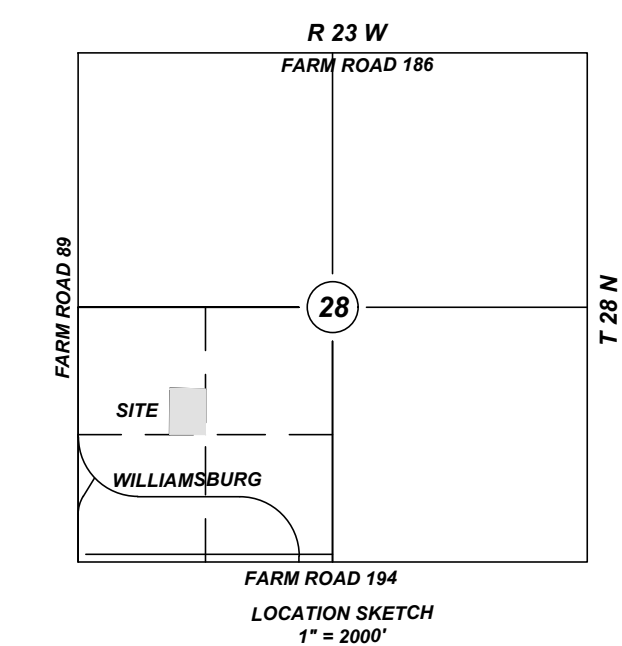
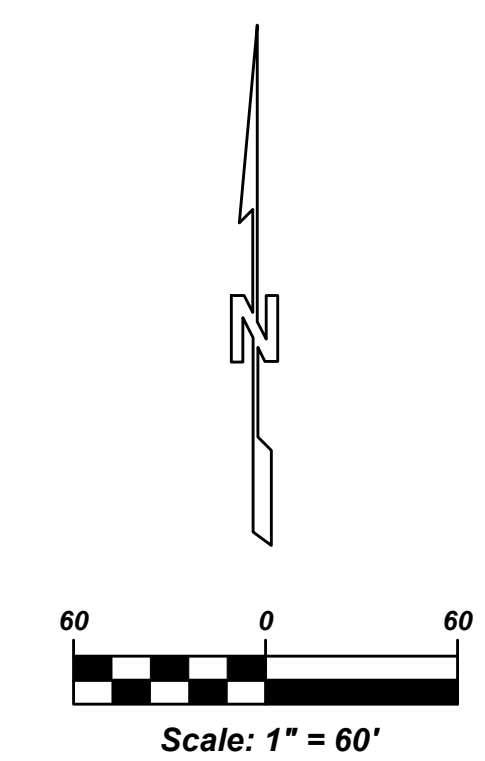
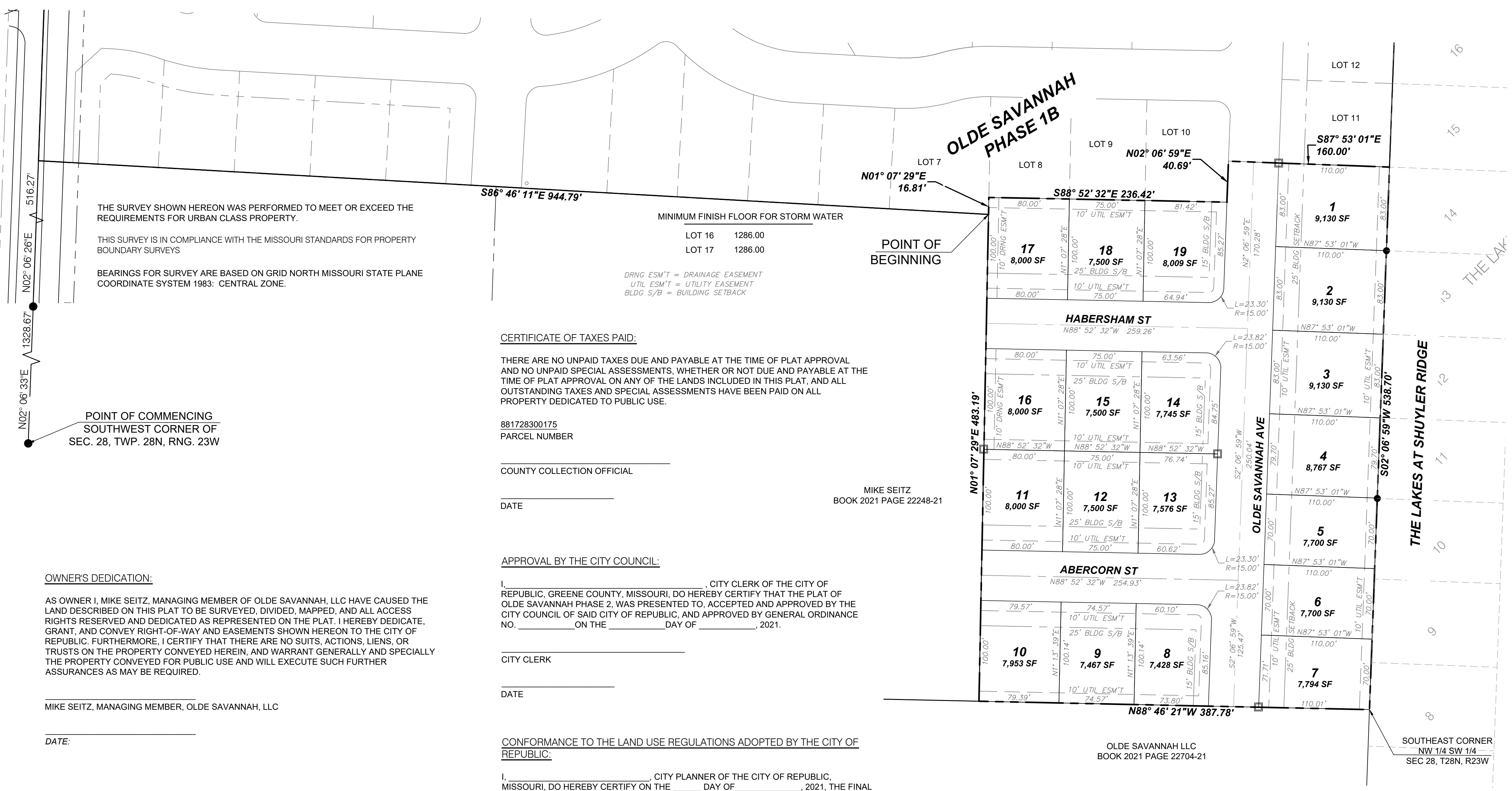

GRID NORTH MISSOURI STATE PLAN  
COORDINATE SYSTEM 1983: CENTRAL ZONE  
MISSOURI GEOGRAPHIC REFERENCE SYSTEM  
STATION: GR-87A  
N: 466761.79 (142289.279 METERS)  
E: 1352304.24 (412183.157 METERS)

**GENERAL NOTES:**

- 1- TOTAL AREA: 202,482 SQ. FT. = 4.65 ACRES (INCLUDES RIGHT-OF-WAY TO BE DEDICATED)
- 2- TOTAL NUMBER OF LOTS: 19
- 3- SMALLEST LOT: LOT 8 (7,428 SQ. FT.)
- 4- LARGEST LOT: LOTS 1, 2 & 3 (9,130 SQ. FT.)
- 5- DATE PRELIMINARY PLAT APPROVED: MAY 19, 2020
- 6- CURRENT ZONING: R1-H HIGH DENSITY SINGLE FAMILY
- 7- SOURCE OF TITLE: BOOK 2020 PAGE 17080-20
- 8- BUILDING SETBACKS -  
FRONT YARD - 25'  
REAR YARD - 25'  
SIDE YARD - 6'  
SIDE YARD W/ STREET FRONTAGE - 15'
- 9- ACCORDING TO FEMA COMMUNITY-PANEL NUMBER 29077C0427E, DATED DECEMBER 17, 2010 THE PROPERTY SHOWN HEREON LIES WITHIN A DESIGNATED FLOOD ZONE X. (AREAS DETERMINED TO BE OUTSIDE THE 0.2% ANNUAL CHANCE FLOODPLAIN)
- 10- THE SURVEY SHOWN HEREON WAS PERFORMED TO MEET OR EXCEED THE REQUIREMENTS FOR URBAN CLASS PROPERTY
- 11- ALL STREET RIGHT OF WAY WILL BE 50 FEET
- 12- SIDEWALK WILL BE ON THE EAST SIDE OF OLDE SAVANNAH AVE, THE NORTH SIDE OF HABERSHAM ST, AND THE NORTH SIDE OF ABERCORN ST
- 13- ALL COMMON AREAS & DRAINAGE AND DETENTION AREAS MUST BE OWNED AND MAINTAINED BY A HOMEOWNER'S ASSOCIATION.

**PROPERTY DESCRIPTION**

A TRACT OF LAND BEING A PART OF THE NORTH-WEST QUARTER OF THE SOUTHWEST QUARTER OF SECTION 28, TOWNSHIP 28 NORTH, RANGE 23 WEST, GREENE COUNTY, MISSOURI, BEING MORE PARTICULARLY DESCRIBED AS FOLLOWS:

COMMENCING AT THE SOUTHWEST CORNER OF SAID SOUTHWEST QUARTER; THENCE NORTH 02°06'33" EAST, ALONG THE WEST LINE OF SAID SOUTHWEST QUARTER, A DISTANCE OF 1328.67 FEET TO THE SOUTHWEST CORNER OF SAID NORTHWEST QUARTER OF THE SOUTHWEST QUARTER; THENCE NORTH 02°06'28" EAST, ALONG THE WEST LINE OF SAID NORTHWEST QUARTER OF THE SOUTHWEST QUARTER, A DISTANCE OF 516.27 FEET; THENCE SOUTH 86°46'11" EAST, A DISTANCE OF 944.79 FEET TO THE POINT OF BEGINNING; THENCE NORTH 01°07'29" EAST, A DISTANCE OF 16.81 FEET; THENCE SOUTH 88°52'32" EAST, A DISTANCE OF 236.42 FEET; THENCE NORTH 02°06'59" EAST, A DISTANCE OF 40.69 FEET; THENCE SOUTH 87°53'01" EAST, A DISTANCE OF 160.00 FEET TO A POINT ON THE EAST LINE OF SAID NORTHWEST QUARTER OF THE SOUTHWEST QUARTER; THENCE SOUTH 02°06'59" WEST, ALONG THE EAST LINE OF SAID NORTHWEST QUARTER OF THE SOUTHWEST QUARTER, ALSO BEING THE WEST LINE OF THE LAKES AT SHUYLER RIDGE, A SUBDIVISION RECORDED IN PLAT BOOK 22 AT PAGE 279 GREENE COUNTY RECORDER'S OFFICE, A DISTANCE OF 538.70 FEET TO THE SOUTHWEST CORNER OF SAID NORTHWEST QUARTER OF THE SOUTHWEST QUARTER; THENCE NORTH 88°46'21" WEST, ALONG THE SOUTH LINE OF SAID NORTHWEST QUARTER OF THE SOUTHWEST QUARTER, A DISTANCE OF 387.78 FEET; THENCE NORTH 01°07'29" EAST, A DISTANCE OF 483.19 FEET TO THE POINT OF BEGINNING, CONTAINING 202,482 SQUARE FEET OR 4.65 ACRES.

**CERTIFICATE OF TAXES PAID:**

THERE ARE NO UNPAID TAXES DUE AND PAYABLE AT THE TIME OF PLAT APPROVAL AND NO UNPAID SPECIAL ASSESSMENTS, WHETHER OR NOT DUE AND PAYABLE AT THE TIME OF PLAT APPROVAL ON ANY OF THE LANDS INCLUDED IN THIS PLAT, AND ALL OUTSTANDING TAXES AND SPECIAL ASSESSMENTS HAVE BEEN PAID ON ALL PROPERTY DEDICATED TO PUBLIC USE.

881728300175  
PARCEL NUMBER

COUNTY COLLECTION OFFICIAL

DATE

MIKE SEITZ  
BOOK 2021 PAGE 22248-21

**APPROVAL BY THE CITY COUNCIL:**

I, \_\_\_\_\_, CITY CLERK OF THE CITY OF REPUBLIC, GREENE COUNTY, MISSOURI, DO HEREBY CERTIFY THAT THE PLAT OF OLDE SAVANNAH PHASE 2, WAS PRESENTED TO, ACCEPTED AND APPROVED BY THE CITY COUNCIL OF SAID CITY OF REPUBLIC, AND APPROVED BY GENERAL ORDINANCE NO. \_\_\_\_\_ ON THE \_\_\_\_\_ DAY OF \_\_\_\_\_, 2021.

CITY CLERK

DATE

**CONFORMANCE TO THE LAND USE REGULATIONS ADOPTED BY THE CITY OF REPUBLIC:**

I, \_\_\_\_\_, CITY PLANNER OF THE CITY OF REPUBLIC, MISSOURI, DO HEREBY CERTIFY ON THE \_\_\_\_\_ DAY OF \_\_\_\_\_, 2021, THE FINAL PLAT OF OLDE SAVANNAH PHASE 2, CONFORMS TO THE CITY OF REPUBLIC LAND USE REGULATIONS, IN ACCORDANCE WITH TITLE IV OF THE REPUBLIC CODE OF ORDINANCES.

CITY PLANNER

**SURVEYOR'S DECLARATION:**

THAT I, JAMES A. VAUGHAN DO HEREBY DECLARE THAT THIS PLAT WAS PREPARED UNDER MY SUPERVISION FROM AN ACTUAL SURVEY OF THE LAND HEREIN DESCRIBED PREPARED BY CJW DATED APRIL 20, 2020 AND THAT THE CORNER MONUMENTS AND LOT CORNER PINS SHOWN HEREIN WERE PLACED UNDER MY PERSONAL SUPERVISION IN ACCORDANCE WITH CURRENT MISSOURI STANDARDS FOR BOUNDARY SURVEYS AS PROMULGATED BY THE MISSOURI DEPARTMENT OF AGRICULTURE.

DATE PREPARED: AUGUST 02, 2021

SIGNATURE: \_\_\_\_\_ MO PLS NO. 002555

DATE: \_\_\_\_\_

**OWNERS DEDICATION:**

AS OWNER I, MIKE SEITZ, MANAGING MEMBER OF OLDE SAVANNAH, LLC HAVE CAUSED THE LAND DESCRIBED ON THIS PLAT TO BE SURVEYED, DIVIDED, MAPPED, AND ALL ACCESS RIGHTS RESERVED AND DEDICATED AS REPRESENTED ON THE PLAT. I HEREBY DEDICATE, GRANT, AND CONVEY RIGHT-OF-WAY AND EASEMENTS SHOWN HEREON TO THE CITY OF REPUBLIC. FURTHERMORE, I CERTIFY THAT THERE ARE NO SUITS, ACTIONS, LIENS, OR TRUSTS ON THE PROPERTY CONVEYED HEREIN, AND WARRANT GENERALLY AND SPECIALLY THE PROPERTY CONVEYED FOR PUBLIC USE AND WILL EXECUTE SUCH FURTHER ASSURANCES AS MAY BE REQUIRED.

MIKE SEITZ, MANAGING MEMBER, OLDE SAVANNAH, LLC

DATE:

**ACKNOWLEDGEMENT OF LIMITED LIABILITY COMPANY**

STATE OF MISSOURI )  
                                  ) SS  
COUNTY OF GREENE )

ON THIS \_\_\_\_\_ DAY OF \_\_\_\_\_, 2021, BEFORE ME PERSONALLY APPEARED MIKE SEITZ, TO ME KNOWN, WHO, DULY SWORN, DID SAY THAT HE IS THE MANAGING MEMBER OF OLDE SAVANNAH, LLC, LIMITED LIABILITY COMPANY ORGANIZED AND EXISTING UNDER THE LAWS OF THE STATE OF MISSOURI AND THAT HE EXECUTED THE FOREGOING INSTRUMENT IN THE NAME OF THE ENTITY, AND THAT HE HAD THE AUTHORITY TO SIGN THE SAME AND ACKNOWLEDGED SAID INSTRUMENT TO BE THE FREE ACT AND DEED OF THE SAID LIMITED LIABILITY COMPANY. IN WITNESS WHEREOF, I HAVE HEREUNTO SET MY HAND AND AFFIXED MY OFFICIAL SEAL IN MY OFFICE IN \_\_\_\_\_ COUNTY, MISSOURI.

NOTARY PUBLIC: \_\_\_\_\_

MY COMMISSION EXPIRES: \_\_\_\_\_

<b>No.:</b>	<b>Revision:</b>	<b>Date:</b>	<b>FINAL PLAT OF OLDE SAVANNAH SUBDIVISION PHASE 2</b>		
			<b>SW1/4 SEC. 28, TWP. 28N, RNG. 23W CITY OF REPUBLIC, GREENE CO., MISSOURI</b>		
<b>Prepared by:</b>					
<b>CJW</b> CJW Transportation Consultants, L.L.C.					
5051 S. National Suite 7A Springfield, MO 65810		Tel: 417.889.3400 Fax: 417.889.3402			
www.GoCJW.com					
SURVEY BY CJW		DESIGN CJW		SCALES HOR. 1"=60' VERT. N/A	
DATE 08-02-2021		DRAWN CJW		SHEET 1 OF 1 SHEETS	
DWG FINAL PLAT		CHECKED CJW		FILE NO. 20155	

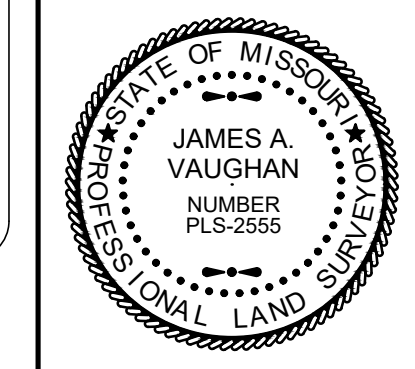



## AGENDA ITEM ANALYSIS

Project/Issue Name: 21-63 An Ordinance of the City Council of the City of Republic, Missouri, Approving the Final Plat of Monte Cristo Phase 10 Subdivision.

Submitted By: Karen Haynes, Assistant BUILDS Administrator

Date: October 19, 2021

### Issue Statement

The City of Republic's BUILDS Department received a Final Plat Application for the Monte Cristo Phase 10 Subdivision on September 15, 2021.

### Discussion and/or Analysis

The Final Plat of Monte Cristo Phase 10 will legally divide approximately fifteen point five (15.5) acres of land into forty (40) residential lots and includes the dedication of Right-of-Way, Utility, and Stormwater Easements. The Final Plat includes approximately (3253) linear feet of street and (3674) linear feet of sidewalk.

The Final Plat of Monte Cristo Phase 10 conforms to the Preliminary Plat approved by City Council on March 27, 2006.

City Staff has reviewed the Final Plat and has determined that it substantially conforms to the requirements of the Preliminary Plat, in addition to the requirements of the City Code Chapter 410 Subdivision Regulations, and Article V Major Subdivision-Final Plat.

### Recommended Action

Staff recommends approval of the Monte Cristo Phase 10 Final Plat.



**AN ORDINANCE OF THE CITY COUNCIL OF THE CITY OF REPUBLIC, MISSOURI, APPROVING THE FINAL PLAT OF MONTE CRISTO PHASE TEN SUBDIVISION**

**WHEREAS**, the City of Republic, Missouri, (herein called the “City” or “Republic”) is a municipal corporation and Charter City located in Greene County, Missouri, being duly created, organized, and existing under the laws of the State of Missouri; and

**WHEREAS**, the Preliminary Plat of the Monte Cristo Subdivision (herein called “Subdivision”) was approved by the Council on March 27, 2006, in Resolution; and

**WHEREAS**, an application for the review and approval of the Final Plat of the Subdivision was received by the BUILDS Department, after which the BUILDS Department staff caused the review of the Final Plat; and

**WHEREAS**, the minimum required public improvements for the Subdivision’s Final Plat have been inspected and approved by the BUILDS Department.

**NOW, THEREFORE, BE IT ORDAINED BY THE CITY COUNCIL OF THE CITY OF REPUBLIC, MISSOURI, AS FOLLOWS:**

- Section 1:** That all conditions imposed by the Planning and Zoning Commission and the City Council relating to the acceptance and approval of the Subdivision have been met.
- Section 2:** That the Final Plat of the Subdivision, attached hereto and incorporated herein as “Attachment 1”, is hereby approved in all respects.
- Section 3:** That the approval of the Final Plat of the Subdivision is contingent upon the same being recorded within sixty days after the approval certificate is signed and sealed under the hand of the City Clerk.
- Section 4:** That the sale of lots and construction of structures in the Subdivision shall not commence until the Final Plat has been recorded.
- Section 5:** Whereas clauses are hereby specifically incorporated herein by reference.
- Section 6:** The provisions of this Ordinance are severable and if any provision hereof is declared invalid, unconstitutional, or unenforceable, such determination shall not affect the validity of the remainder of this Ordinance.
- Section 7:** This Ordinance shall take effect and be in force from and after its passage as provided by law.

**PASSED AND APPROVED** at a regular meeting of the City Council of the City of Republic, Missouri, this \_\_\_\_\_ day of \_\_\_\_\_, 2021.

\_\_\_\_\_  
Matt Russell, Mayor

Attest:

\_\_\_\_\_  
Laura Burbridge, City Clerk

DocuSigned by:  
*Damon Phillips* 9/27/2021  
11E90D87116B4F4...

Approved as to Form: \_\_\_\_\_ Damon Phillips, City Attorney

Final Passage and Vote: \_\_\_\_\_

# SUBD-FNL 21-008: Monte Cristo Phase 10

Item 5.

## Vicinity Map

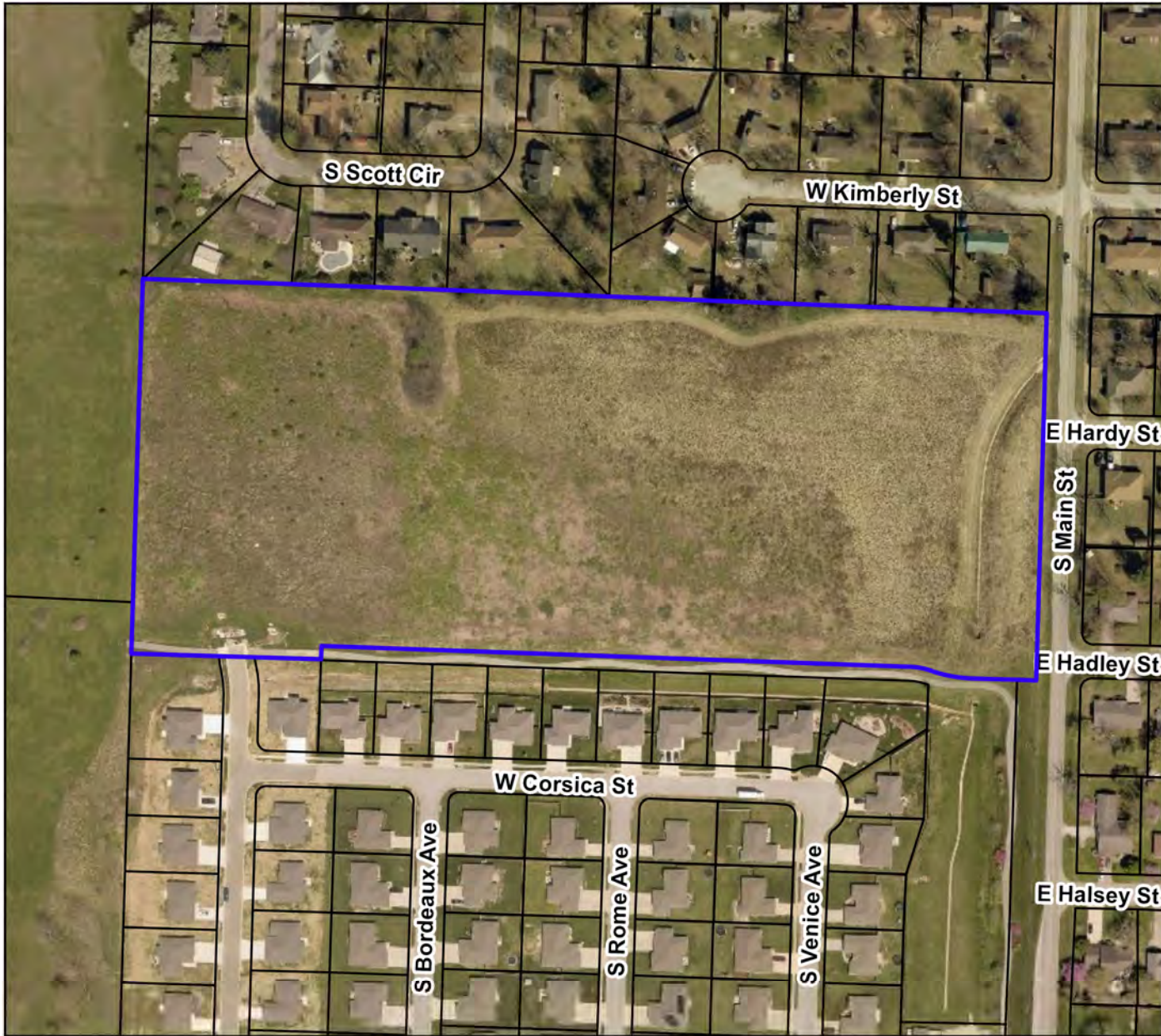

### Legend

-  Monte Cristo 10
-  Parcels
-  Sinkhole
-  Floodplain

Parcel Owner: RLDC LLC  
Parcel Address: Northern Termination of S. Calabria Ave.  
Area: 15.5 acres  
Zoning: PDD (Monte Cristo)  
Number of Lots: 40

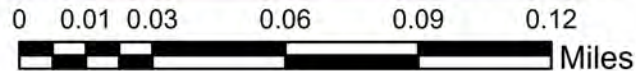

PROPERTY DESCRIPTION:

MONTE CRISTO SUBDIVISION PHASE TEN A TRACT OF LAND LOCATED IN THE SOUTHEAST QUARTER OF THE NORTHEAST QUARTER OF SECTION 30, TOWNSHIP 28 NORTH, RANGE 23 WEST, ALL BEING IN REPUBLIC, GREENE COUNTY, MISSOURI AND BEING MORE PARTICULARLY DESCRIBED AS FOLLOWS:

BEGINNING AT THE SOUTHWEST CORNER OF SCOTT ACRES 1ST ADDITION, A SUBDIVISION RECORDED IN PLAT BOOK AA PAGE 78 GREENE COUNTY RECORDER'S OFFICE; THENCE SOUTH 87°33'53" EAST, ALONG THE SOUTH LINE OF SAID SUBDIVISION, A DISTANCE OF 226.90 FEET TO AN EXISTING FENCE; THENCE SOUTH 01°28'14" WEST, LEAVING SAID SOUTH LINE AND ALONG SAID FENCE, A DISTANCE OF 3.84 FEET; THENCE SOUTH 87°49'52" EAST, ALONG SAID FENCE, A DISTANCE OF 589.38 FEET; THENCE NORTH 03°18'04" EAST, ALONG SAID FENCE, A DISTANCE OF 1.10 FEET TO A POINT ON THE SOUTH LINE OF CHASTAIN SUBDIVISION, A SUBDIVISION RECORDED IN PLAT BOOK HH PAGE 22 GREENE COUNTY RECORDER'S OFFICE; THENCE SOUTH 87°33'53" EAST, ALONG SAID SOUTH LINE, A DISTANCE OF 479.81 FEET TO A POINT ON THE WEST RIGHT OF WAY OF HIGHWAY P; THENCE SOUTH 01°55'05" WEST, ALONG SAID WEST RIGHT OF WAY, A DISTANCE OF 524.01 FEET; THENCE NORTH 88°10'32" WEST, ALONG AN EXTENSION OF THE NORTH LINE OF THE CITY OF REPUBLIC DEDICATED WALKING TRAIL RIGHT OF WAY, ALSO BEING THE NORTH LINE OF MONTE CRISTO PHASE ONE, A SUBDIVISION RECORDED IN PLAT BOOK AAA PAGE 17 GREENE COUNTY RECORDER'S OFFICE, A DISTANCE OF 93.14 FEET; THENCE WESTERLY 54.59 FEET, ALONG SAID NORTH LINE AND ALONG A 180.00 FOOT RADIUS CURVE TO THE RIGHT, HAVING A CHORD BEARING AND DISTANCE OF NORTH 79°29'13" WEST, 54.38 FEET; THENCE WESTERLY 36.10 FEET, ALONG SAID NORTH LINE AND ALONG A 120.00 FOOT RADIUS CURVE TO THE LEFT, HAVING A CHORD BEARING AND DISTANCE OF NORTH 79°25'00" WEST, 35.97 FEET; THENCE NORTH 88°02'12" WEST, ALONG SAID NORTH LINE, A DISTANCE OF 845.51 FEET TO THE NORTHWEST CORNER OF SAID MONTE CRISTO PHASE ONE; THENCE SOUTH 01°58'15" WEST, ALONG THE WEST LINE OF SAID MONTE CRISTO PHASE ONE, A DISTANCE OF 20.00 FEET TO THE NORTHEAST CORNER OF MONTE CRISTO PHASE 4, A SUBDIVISION RECORDED IN PLAT BOOK AAA PAGE 577 GREENE COUNTY RECORDER'S OFFICE; THENCE NORTH 88°03'00" WEST, ALONG THE NORTH LINE OF SAID MONTE CRISTO PHASE 4, A DISTANCE OF 267.92 TO THE WEST LINE OF THE SOUTHEAST QUARTER OF THE NORTHEAST QUARTER OF SAID SECTION 30; THENCE NORTH 01°53'50" EAST, ALONG SAID WEST LINE, A DISTANCE OF 541.50 FEET TO THE POINT OF BEGINNING. CONTAINING 674,629 SQUARE FEET OR 15.5 ACRES

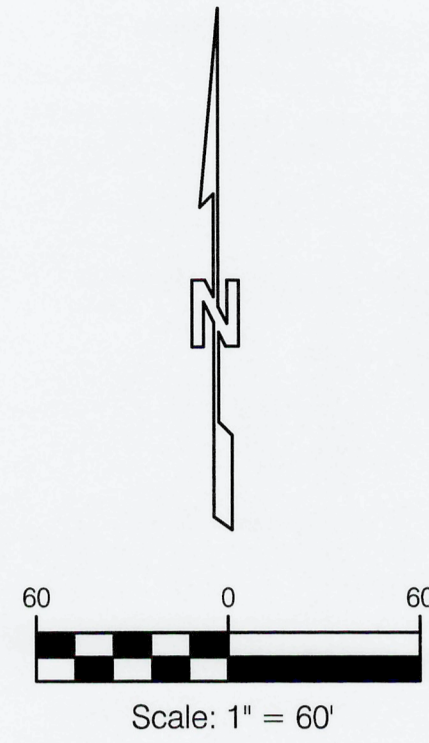

GRID NORTH MISSOURI STATE PLAN COORDINATE SYSTEM 1983: CENTRAL ZONE ELEVATIONS BASED ON MISSOURI GEOGRAPHIC REFERENCE SYSTEM STATION: GR-87A

FINAL PLAT OF MONTE CRISTO SUBDIVISION PHASE 10

SE 1/4 NE 1/4 SEC 30, T28N, R23W REPUBLIC, GREENE COUNTY, MISSOURI

OWNER/DEVELOPER

RLDC LLC 3800 S FREMONT AVE SPRINGFIELD MO 65804

LEGEND

- EXISTING IRON PIN
○ 5/8" IRON PIN (SEMI PERMANENT 5/8"x18" REBAR PLASTIC CAPPED 'LC-2007080006') (SET AT ALL LOT CORNERS UNLESS OTHERWISE NOTED)
□ PERMANENT MONUMENT SET, 5/8"x24" REBAR WITH 1 AND 3/4 INCH PLASTIC CAP STAMPED 'LC 2007080003'
M MEASURED
P PLATTED
D DEEDED

GENERAL NOTES:

- 1. - TOTAL AREA: 15.5 ACRES (INCLUDES RIGHT-OF-WAY TO BE DEDICATED)
2. - TOTAL NUMBER OF LOTS: 40
3. - SMALLEST LOT: LOT 2, 3, 5 - 11, 24 & 37 (9000 SQ. FT.)
4. - LARGEST LOT: LOT 16 (15,737 SQ. FT.)
5. - DATE PRELIMINARY PLAT APPROVED: MARCH 27, 2006
6. - CURRENT ZONING: MONTE CRISTO PDD
7. - SOURCE OF TITLE: BOOK 2015 PAGE 2943215
8. - BUILDING SETBACKS - FRONT YARD - 25' REAR YARD - 25' SIDE YARD - 6' SIDE YARD W/ STREET FRONTAGE - 25'
9. - ACCORDING TO FEMA COMMUNITY-PANEL NUMBER 29077C0426E, DATED DECEMBER 17, 2010 THE PROPERTY SHOWN HEREON LIES WITHIN A DESIGNATED FLOOD ZONE X. (AREAS DETERMINED TO BE OUTSIDE THE 0.2% ANNUAL CHANCE FLOODPLAIN.)
10. - ALL COMMON AREAS & DRAINAGE AND DETENTION AREAS MUST BE OWNED AND MAINTAINED BY A HOMEOWNER'S ASSOCIATION.
11. - THE SURVEY SHOWN HEREON WAS PERFORMED TO MEET OR EXCEED THE ACCURACY REQUIREMENTS FOR URBAN CLASS PROPERTY

OWNERS DEDICATION:

AS OWNER I, MIKE SEITZ, MANAGING MEMBER OF RLDC, LLC HAVE CAUSED THE LAND DESCRIBED ON THIS PLAT TO BE SURVEYED, DIVIDED, MAPPED, AND ALL ACCESS RIGHTS RESERVED AND DEDICATED AS REPRESENTED ON THE PLAT. I HEREBY DEDICATE, GRANT, AND CONVEY RIGHT-OF-WAY AND EASEMENTS SHOWN HEREON TO THE CITY OF REPUBLIC. FURTHERMORE, I CERTIFY THAT THERE ARE NO SUITS, ACTIONS, LIENS, OR TRUSTS ON THE PROPERTY CONVEYED HEREIN, AND WARRANT GENERALLY AND SPECIALLY THE PROPERTY CONVEYED FOR PUBLIC USE AND WILL EXECUTE SUCH FURTHER ASSURANCES AS MAY BE REQUIRED.

MIKE SEITZ, MANAGING MEMBER, RLDC, LLC

DATE:

ACKNOWLEDGEMENT OF LIMITED LIABILITY COMPANY

STATE OF MISSOURI ) COUNTY OF GREENE )

ON THIS DAY OF 2021, BEFORE ME PERSONALLY APPEARED MIKE SEITZ, TO ME KNOWN, WHO, DULY SWORN, DID SAY THAT HE IS THE MANAGING MEMBER OF RLDC, LLC, LIMITED LIABILITY COMPANY OF THE STATE OF MISSOURI AND THAT HE EXECUTED THE FOREGOING INSTRUMENT ON BEHALF OF THE LLC, AND THAT HE HAD THE AUTHORITY TO SIGN THE SAME AND ACKNOWLEDGED SAID INSTRUMENT TO BE THE FREE ACT AND DEED OF THE SAID LLC. IN WITNESS WHEREOF, I HAVE HEREUNTO SET MY HAND AND AFFIXED MY OFFICIAL SEAL IN MY OFFICE IN COUNTY, MISSOURI.

NOTARY PUBLIC:

MY COMMISSION EXPIRES:

CERTIFICATE OF TAXES PAID:

THERE ARE NO UNPAID TAXES DUE AND PAYABLE AT THE TIME OF PLAT APPROVAL AND NO UNPAID SPECIAL ASSESSMENTS, WHETHER OR NOT DUE AND PAYABLE AT THE TIME OF PLAT APPROVAL ON ANY OF THE LANDS INCLUDED IN THIS PLAT, AND ALL OUTSTANDING TAXES AND SPECIAL ASSESSMENTS HAVE BEEN PAID ON ALL PROPERTY DEDICATED TO PUBLIC USE.

1730101175 PARCEL NUMBER

COUNTY COLLECTION OFFICIAL

DATE

APPROVAL BY THE CITY COUNCIL:

I, LAURA BURBRIDGE, CITY CLERK OF THE CITY OF REPUBLIC, DO HEREBY CERTIFY THAT THE PLAT OF MONTE CRISTO PHASE 10, WAS PRESENTED, ACCEPTED AND APPROVED BY THE CITY COUNCIL OF SAID CITY OF REPUBLIC, AND APPROVED BY GENERAL ORDINANCE NO. ON THE DAY OF 2021.

CITY CLERK

DATE

CONFORMANCE TO THE LAND USE REGULATIONS ADOPTED BY THE CITY OF REPUBLIC:

I, CITY PLANNER OF THE CITY OF REPUBLIC, MISSOURI, DO HEREBY CERTIFY ON THE DAY OF 2021, THE FINAL PLAT OF MONTE CRISTO PHASE 10, CONFORMS TO THE CITY OF REPUBLIC LAND USE REGULATIONS, IN ACCORDANCE WITH TITLE IV OF THE REPUBLIC CODE OF ORDINANCES.

CITY PLANNER

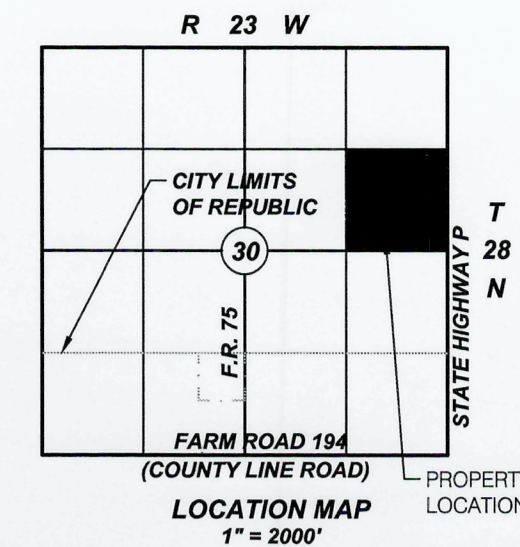

SPACE RESERVED FOR GREENE COUNTY RECORDER

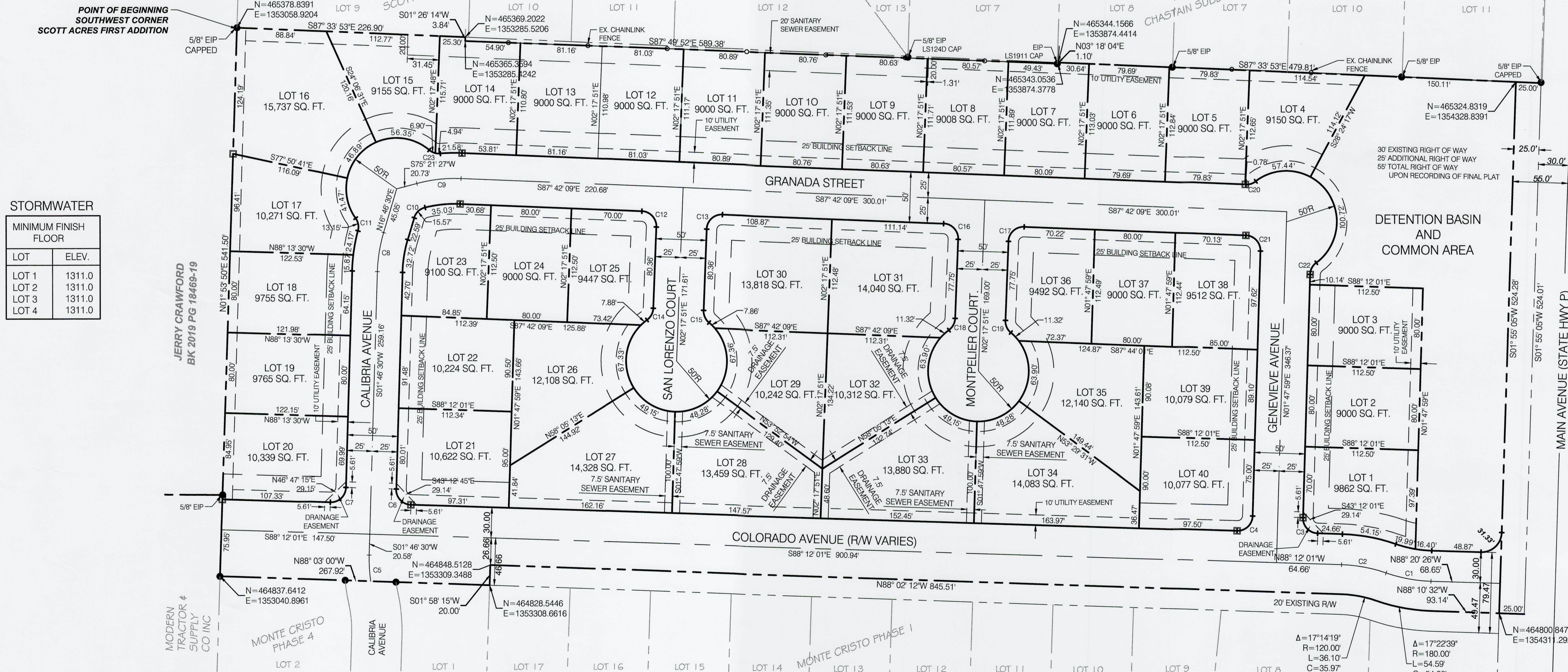

Table with 2 columns: LOT, ELEV. Rows 1-4.

Curve Table with columns: Curve #, Length, Radius, Delta, Chord Direction, Chord Length. Rows C1-C12.

Curve Table with columns: Curve #, Length, Radius, Delta, Chord Direction, Chord Length. Rows C13-C23.

DRAINAGE/Common AREA NOTE:

CITY OF REPUBLIC RIGHTS. NOTWITHSTANDING ANY OTHER PROVISION TO THE CONTRARY WITHIN THIS DECLARATION, AND IN CONJUNCTION WITH THE POWERS GRANTED TO THE CITY OF REPUBLIC UNDER TITLE IV, LAND USE, ET SEQ., AS AMENDED, READOPTED OR RE-CODIFIED FROM TIME TO TIME, WHICH IS INCORPORATED HEREIN BY REFERENCE, IN THE EVENT FOR ANY REASON THE ASSOCIATION SHOULD FAIL TO MAINTAIN ANY COMMON AREA OR AREAS, OR IN THE EVENT THE ASSOCIATION SHOULD BE DISSOLVED FOR ANY REASON OR CEASE TO EXIST, AND THE LOT OWNERS (UNIT OWNERS FOR CONDOMINIUMS) FAIL TO MAINTAIN SUCH COMMON AREA OR AREAS, THEN THE CITY SHALL HAVE THE RIGHT AND FULL AUTHORITY AND ABILITY TO INTERCEDE AND MAINTAIN THE COMMON AREAS AND ASSESS THE CITY'S COSTS OF SAME TO THE LOT OWNERS (OR UNIT OWNERS) WITHIN THE SUBDIVISION (OR CONDOMINIUM) OR ANY LOT (UNIT) OR PARCELS PREVIOUSLY SERVED BY THE ASSOCIATION OR ANY OF THE COMMON AREAS OF THE SUBDIVISION (CONDOMINIUM), ON A PRO RATA BASIS OF SQUARE FOOTAGE OF THE LOTS (UNITS) WITHIN THE AREA PREVIOUSLY SERVED BY THE ASSOCIATION AND SUCH SHALL RUN AS A LIEN AGAINST THE LOTS. THE CITY SHALL BE GIVEN THE POWER PROVIDED HEREIN, AS WELL AS ANY OTHER REMEDY AVAILABLE TO IT UNDER LAW, TO SET AND ENFORCE SUCH ASSESSMENTS TO PAY FOR THE MAINTENANCE OF, OR ABATEMENT OF ANY NUISANCE CONTAINED IN, ANY COMMON AREA OR AREAS.

SURVEYORS DECLARATION:

THAT I, JAMES A. VAUGHAN DO HEREBY DECLARE THAT THIS PLAT WAS PREPARED UNDER MY SUPERVISION FROM AN ACTUAL SURVEY OF THE LAND HEREIN DESCRIBED PREPARED BY C.J.W. DATED DECEMBER 13, 2017 AND THAT THE CORNER MONUMENTS AND LOT CORNER PINS SHOWN HEREIN WERE PLACED UNDER MY PERSONAL SUPERVISION IN ACCORDANCE WITH CURRENT MISSOURI STANDARDS FOR BOUNDARY SURVEYS AS PROMULGATED BY THE MISSOURI DEPARTMENT OF AGRICULTURE

DATE PREPARED: JULY 23, 2021 SIGNATURE: [Signature] MO PLS NO. 002555 DATE: 10/03/2021

Professional seal for James A. Vaughan, Missouri Professional Land Surveyor, and logo for CJW Transportation Consultants, LLC.

Final plat title block containing project name, location, survey details, and drawing information.

## AGENDA ITEM ANALYSIS

Project/Issue Name: 21-64 An Ordinance of the City Council of the City of Republic, Missouri, Amending Title I, Government Code, Chapter 110, Administrative Policies, Article VIII, Authority to Enter into Contracts Policy and Chapter 120, City Officers and Employees, Article IV, Miscellaneous Provisions.

Submitted By: Karen Haynes, BUILDS Assistant Administrator  
Laura Burbridge, City Clerk

Date: October 19, 2021

### Issue Statement

Consideration to approve amendments to Section 110.200, Persons Authorized to Enter into Contracts on Behalf of City and 120.140, Acceptance of Easements Dedicated to Public Use.

### Discussion and/or Analysis

The City of Republic is requesting Amendments to Section 110.200 to adhere to the Purchasing Policy adopted by Council on April 6, 2021 and amend Section 120.140 changing the Director of Public Works to the BUILDS Administrator or their designee and granting authority to accept deficient right-of-way for projects not requiring platting.

#### 110.200 Persons Authorized To Enter Into Contracts On Behalf Of City

The City Administrator and Finance Director are hereby authorized to enter into contracts on behalf of the City without prior City Council approval in an amount not to exceed ~~twenty-five~~fifty thousand dollars (\$~~25~~50,000.00) in value, provided that the City Administrator and Finance Director jointly approve entry into such contracts and that the City Council has appropriated funds for such contracts in the budget or by City Council action.

#### 120.140 Acceptance Of Easements And Right-of-Way Dedicated To Public Use

- A. The ~~Director of Public Works~~ BUILDS Administrator or their designee may accept easements and deficient right-of-way on behalf of the City when all of the conditions in Subsections (1) through (3) exist and at least one (1) of the conditions in Subsection (4) exists.
1. The easement or deficient right-of-way dedication is offered at no cost to the City or can be obtained at a cost that does not exceed the authorizations for purchases established in the City purchasing manual for a department head or the City Administrator;

2. The easement or deficient right-of-way dedication is adjacent to, or an extension of an existing easement or right-of-way or other public infrastructure improvement owned by or dedicated to the City;
3. The easement or deficient right-of-way dedication is necessary for the proposed or planned construction or maintenance of a public improvement or storm water drainage area;
4. The easement or right-of-way is necessary or expedient:
  - a) To follow a maintenance directive of the City Council;
  - b) To improve water, sanitary sewer, and storm water drainage, or right-of-way; or
  - c) To obtain additional right-of-way up to the amount prescribed in the City's Adopted Major Thoroughfare Plan, Transportation Master Plan, or City Code. ~~subdivision regulations of the Land Development Code.~~
5. In addition, the ~~Public Works Director~~ BUILDS Administrator or their designee may accept easements or deficient right-of-way as part of a project for which obtaining easements and/or right-of-way was a known element of the project and proceeding with the project has been approved by City Council. This authorization is subject to meeting the requirements of the City purchasing manual for expenditures if not otherwise authorized by City Council.

**Recommended Action**

Staff recommends approval.

**AN ORDINANCE OF THE CITY COUNCIL OF THE CITY OF REPUBLIC, MISSOURI, AMENDING TITLE I, GOVERNMENT CODE, CHAPTER 110, ADMINISTRATION POLICIES, ARTICLE VIII, AUTHORITY TO ENTER INTO CONTRACTS POLICY AND CHAPTER 120, CITY OFFICERS AND EMPLOYEES, ARTICLE VI, MISCELLANEOUS PROVISIONS**

**WHEREAS**, the City of Republic, Missouri, (herein called the "City" or "Republic") isa municipal corporation and Charter City located in Greene County, Missouri, being duly created, organized, and existing under the laws of the State of Missouri; and

**WHEREAS**, on April 6, 2021, in Ordinance 21-18, the City Council adopted a new purchasing policy contained in Section 110.020 of the Municipal Code of the City of Republic, Missouri; and

**WHEREAS**, the purchasing policy adopted in Ordinance 21-18 omitted amending Section 110.200 regarding the not to exceed amount the City Administrator and Finance Director may enter into for contracts on behalf of the City without prior City Council approval; and

**WHEREAS**, the City of Republic has recognized the need to continually review and revise the Municipal Code of the City of Republic, Missouri to accurately reflect staff titles and terminology used within the City;

**WHEREAS**, authorizing the BUILDS Administrator or their designee to accept right-of-way dedications in addition to easements for public use under certain conditions will provide the grantors, the City, and the public which it serves, greater flexibility in proceeding with public improvements.

**NOW THEREFORE, BE IT ORDAINED BY THE COUNCIL OF THE CITY OF REPUBLIC, IN THE STATE OF MISSOURI, AS FOLLOWS:**

Section 1: Title I, Government Code, Chapter 110, Administration Policies, Article VIII, Authority To Enter Into Contracts Policy is hereby amended by amending Section 110.200 Persons Authorized to Enter Into Contracts on Behalf of City to read as follows:

**110.200 Persons Authorized To Enter Into Contracts On Behalf Of City**

The City Administrator and Finance Director are hereby authorized to enter into contracts on behalf of the City without prior City Council approval in an amount not to exceed ~~twenty-five~~ **fifty** thousand dollars (~~\$250,000.00~~) in

value, provided that the City Administrator and Finance Director jointly approve entry into such contracts and that the City Council has appropriated funds for such contracts in the budget or by City Council action.

Title I, Government Code, Chapter 120, City Officers and Employees is hereby amended by amending section 120.140 Acceptance Of Easements Dedicated To Public Use to read as follows:

120.140 Acceptance Of Easements **And Right-of-Way** Dedicated To Public Use

A. The ~~Director of Public Works~~ **BUILDS Administrator or their designee** may accept easements **and deficient right-of-way** on behalf of the City when **in the exercise of their discretion they determine that** all of the conditions in Subsections (1) through (3) exist and at least one (1) of the conditions in Subsection (4) exists, **or that the conditions in Subsection (5) exist.**

1. The easement **or deficient right-of-way dedication** is offered at no cost to the City or can be obtained at a cost that does not exceed the authorizations for purchases established in the City purchasing manual for a department head or the City Administrator;
2. The easement **or deficient right-of-way dedication** is adjacent to, or an extension of, an existing easement **or right-of-way** or **other public infrastructure** improvement owned by or dedicated to the City;
3. The easement **or deficient right-of-way dedication** is necessary for the **proposed or planned** construction or maintenance of a public improvement or storm water drainage area;
4. The easement **or right-of-way** is necessary or expedient:
  - a) To follow a maintenance directive of the City Council;
  - b) To improve water, sanitary sewer, ~~and~~ storm water drainage, **or right-of-way**; or
  - c) To obtain additional right-of-way up to the amount prescribed in **the City's Adopted Major Thoroughfare Plan, Transportation Master Plan, or City Code**. ~~subdivision regulations of the Land Development Code.~~



5. In addition, the ~~Public Works Director~~ **BUILDS Administrator or their designee** may accept easements **or deficient right-of-way** as part of a project for which obtaining easements **and/or right-of-way** was a known element of the project and proceeding with the project has been approved by City Council. This authorization is subject to meeting the requirements of the City purchasing manual for expenditures if not otherwise authorized by City Council.

EXPLANATION - Matter in bold-face type in the above is added language. Matter in in the above is deleted.

Section 2. All other Sections of the Municipal Code of the City of Republic, Missouri, not specifically referenced in this Ordinance shall remain unmodified and in full force and effect.

Section 3. The whereas clauses are hereby specifically incorporated herein by reference.

Section 4. The provisions of this Ordinance are severable and if any provision hereof is declared invalid, unconstitutional, or unenforceable, such determination shall not affect the validity of the remainder of this Ordinance.

Section 5. This Ordinance shall take effect and be in force from and after its passage as provided by law.

PASSED AND APPROVED at a regular meeting of the City Council of the City of Republic, Missouri, this\_day of October 2021.

\_\_\_\_\_  
Matt Russell, Mayor

ATTEST:

\_\_\_\_\_  
Laura Burbridge, City Clerk

DocuSigned by:  
*Damon Phillips* 9/29/2021  
11F90D87116B4F4...

Approved as to Form \_\_\_\_\_, Damon Phillips, City Attorney

Final Passage and Vote: \_\_\_\_\_



To: City Council  
 From: Karen Haynes, Assistant BUILDS Administrator  
 Date: October 12, 2021  
 Subject: Deficient Right-of-Way

---

The proposed Chapter 100 Amendment grants the BUILDS Administrator or their Designee the authority to accept Right-of-Way (ROW) in addition to Easements. The Amendment specifically addresses a known gap between the acceptance of ROW by City Council through Final Platting of Major Subdivisions and development which occurs when no platting is required.

Generally, the BUILDS Department defines ROW as, a legal right for public use intended to be occupied by a road, crosswalk, railroad, utilities, or other mechanism for passage obtained by dedication, lawful condemnation, or purchase.

The City's Land Use Ordinances, Transportation Plan, and Major Thoroughfare Plan identify existing ROW and future ROW and more specifically identify the required width of land required for each ROW category.

- Primary Arterial: 110'
- Secondary Arterial: 80'
- Collector: 70'
- Local: 50'

The BUILDS Department generally defines **Deficient ROW**, as any existing or future ROW that is less than that identified by Ordinance or Adopted Plan. Typically, ROW is measured from an existing Section Line from the State Coordinate System or from the centerline of the ROW.

For example, if a property is adjacent to an existing Collector Street (70'); Deficient ROW would be defined as anything less than 35' from the centerline or section line to the property line of the parcel. In this instance, if a Major Subdivision was not proposed, the BUILDS Administrator would have the authority to accept the dedication of Deficient ROW through a Deed of Dedication, which would then be presented to the Greene County Recorder's Office for recording.

# Chapter 100 Memo Map

Item 6.

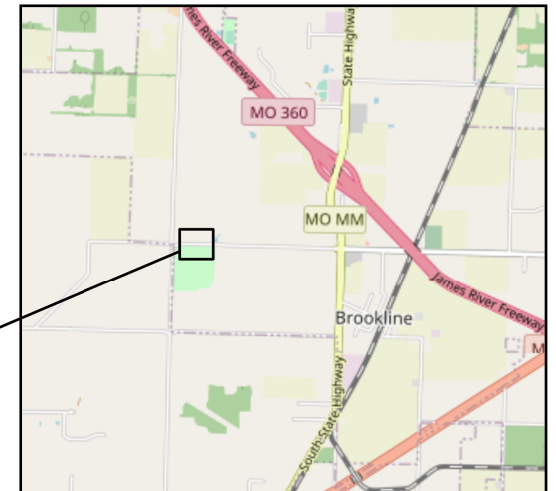

## Legend

- Parcels
- Currently Held ROW
- ROW for Secondary Arterial Street Classification (80 ft)

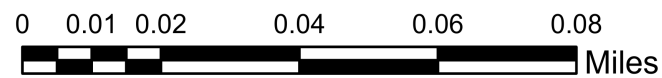



## **AGENDA ITEM ANALYSIS**

Project/Issue Name: 21-65 An Ordinance of the City Council of the City of Republic, Missouri, Authorizing the Execution of an Intergovernmental Agreement with Missouri Department of Social Services Family Support Division Regarding the Low Income Household Water Assistance Program.

Submitted By: Meghin Cook, Finance Director

Date: October 19, 2021

### **Issue Statement**

To authorize an agreement with the Department of Social Services to allow citizens to utilize their Low-Income Household Water Assistance Program for disconnect fees, past due bills, and reconnection fees.

### **Discussion and/or Analysis**

The Low-Income Household Water Assistance Program (LIHWAP) is administered by the Department of Social Services (DSS) and is funded by the Administration of Children and Families. The program will provide up to \$750 for water and wastewater (sewer) disconnection fees, customers who are in threat of disconnection, arrearages (past due bills), and reconnection fees. LIHWAP is expected to begin in Missouri on October 1, 2021, for elderly and disabled households, and November 1, 2021, for other households. This resource will remain available until September 30, 2023 or until all funds are spent.

The City of Republic is resuming utility shut offs beginning October 12<sup>th</sup> and this service would assist those at risk of disconnect avoid being shut off or assist in their services being reinstated.

### **Recommended Action**

Staff recommends approval.

**AN ORDINANCE OF THE CITY COUNCIL OF THE CITY OF REPUBLIC,  
MISSOURI, AUTHORIZING THE EXECUTION OF AN  
INTERGOVERNMENTAL AGREEMENT WITH MISSOURI DEPARTMENT  
OF SOCIAL SERVICES FAMILY SUPPORT DIVISION REGARDING THE LOW  
INCOME HOUSEHOLD WATER ASSISTANCE PROGRAM**

*WHEREAS*, the City of Republic, Missouri, (herein called the "City" or "Republic") is a municipal corporation and Charter City located in Greene County, Missouri, being duly created, organized and existing under the laws of the State of Missouri; and

*WHEREAS*, Section 70.220 RSMo., authorizes governments to cooperate with one another in various matters; and

*WHEREAS*, the Missouri Department of Social Services-Family Support Division has presented an Intergovernmental Agreement setting forth the terms and conditions for providing funds to be used to assist low-income household to have access to drinking and wastewater services, attached in Ex. 1; and

*WHEREAS*, the City Council finds that this Intergovernmental Agreement is in the best interest of the City as it will not only benefit low-income households but also the community as a whole.

***NOW, THEREFORE, BE IT ORDAINED BY THE CITY COUNCIL OF THE CITY OF REPUBLIC, MISSOURI, AS FOLLOWS:***

Section 1. That the Intergovernmental Agreement attached as Ex. 1 is accepted.

Section 2. That Mayor Matt Russell is hereby authorized to execute on behalf of the City of Republic, Missouri, the Intergovernmental Agreement attached as Ex. 1.

Section 3. That the City Administrator or their designee is authorized and directed behalf of the City to take the steps necessary to execute this Ordinance and effect the terms of the ordained agreement described herein.

Section 4. That this Ordinance shall be in full force and effect from and after the date of passage.

***PASSED AND APPROVED*** at a regular meeting of the City Council of the City of Republic, Missouri, this \_\_\_\_ day of October, 2021.

BILL NO. 21-65

ORDINANCE NO. 21-

\_\_\_\_\_  
Matt Russell, Mayor

ATTEST:

\_\_\_\_\_  
Laura Burbridge, City Clerk

DocuSigned by:  
*Damon Phillips*  
11F90D87116B4F4...

10/1/2021

Approved as to Form: \_\_\_\_\_, Damon Phillips, City Attorney

Final Passage and Vote: \_\_\_\_\_

PATRICK LUEBBERING, CHIEF FINANCIAL OFFICER  
DIVISION OF FINANCE AND ADMINISTRATIVE SERVICES  
P.O. BOX 1082 • JEFFERSON CITY, MO 65102-1082  
WWW.DSS.MO.GOV • 573-751-2542 • 573-751-7598 FAX

The Low-Income Household Water Assistance Program (LIHWAP) is administered by the Department of Social Services (DSS) and is funded by the Administration of Children and Families. The program will provide up to \$750 for water and wastewater (sewer) disconnection fees, customers who are in threat of disconnection, arrearages (past due bills), and reconnection fees. LIHWAP is expected to begin in Missouri on October 1, 2021 for elderly and disabled households, and November 1, 2021 for other households.

How the Program Works:

- DSS and Contracted Agencies will notify potentially eligible clients about the availability of the LIHWAP program.
- The client will apply for benefits through DSS Contracted Agencies.
- DSS will send a letter to clients stating they are or are not eligible for the program.
- If the client is eligible, DSS will send a Customer Eligibility Listing (CEL) to the utility company to make a pledge on the clients account.
- If the utility company agrees to accept payment (pledge), DSS will send the payment electronically or with a paper check.
- If the utility company will not accept payment or participate in the program, DSS will send the payment directly to the client.
- Applications will be processed in the order they are received. The program will continue until the funding is spent, or through September 30, 2023.

TDD / TTY: 800-735-2966  
RELAY MISSOURI: 711

For clients to be eligible, they must:

- Be responsible for paying the water and/or wastewater (sewer) bill
- Be a United States citizen (or have been legally admitted for permanent residence)
- Have \$3,000 or less in bank accounts, retirement accounts, or investments
- Meet specific income guidelines based on household size

Client's Income Guidelines Requirements

Household Size	Household Must be Under the Below Monthly Income Amounts to Receive the Benefit
1	\$0 - \$2,211
2	\$0 - \$2,891
3	\$0 - \$3,571
4	\$0 - \$4,252
5	\$0 - \$4,932
6	\$0 - \$5,612
7	\$0 - \$5,740

Utility companies can participate in the program by:

1. Signing the attached "Supplier Agreement" and returning it to DSS at:
  - Email: [fsd.lihwap@dss.mo.gov](mailto:fsd.lihwap@dss.mo.gov), OR
  - Fax: (573) 522-9557, OR
  - Mail to:
 

Department of Social Services/LIHWAP  
3418 Knipp Dr. Ste. C  
Jefferson City, MO 65109
2. Register in MissouriBuys. Please see the attached "Missouri Buys Vendor Registration Checklist" for more information.



## Contracted Agency Contacts

**Audrain, Boone, Callaway, Cole, Cooper, Howard, Moniteau, and Osage:**  
Central Missouri Community Action Agency - (573) 443-1100

**St. Louis County:** Community Action Agency of St. Louis County - (314) 446-4420

**Andrew, Buchanan, Clinton, and DeKalb:**  
Community Action Partnership of Greater St. Joseph - (816) 233-8281

**Atchison, Gentry, Holt, Nodaway, and Worth:**  
Community Services, Inc. of Northwest Missouri - (660) 582-3113

**Barton, Jasper, Newton, and McDonald:**  
Economic Security Corporation of Southwest Area - (417) 781-0352

**Bollinger, Cape Girardeau, Iron, Madison, Perry, St. Francois, St. Genevieve, and Washington:**  
East Missouri Action Agency - (800) 392-8663

**Dunklin, Mississippi, New Madrid, Pemiscot, Scott, and Stoddard:**  
Delta Area Economic Opportunity Corporation - (573) 379-3851

**Caldwell, Daviess, Grundy, Harrison, Linn, Livingston, Mercer, Putnam, and Sullivan:**  
Community Action Partnership North Central Missouri - (660) 359-3907

**City of St. Louis and Wellston:** Urban League - (314) 615-3632

**Jefferson and Franklin:** Jefferson-Franklin Community Action Corporation - (636) 789-2686

**Camden, Crawford, Gasconade, Laclede, Maries, Miller, Phelps, and Pulaski:**  
Missouri Ozarks Community Action, Inc. - (573) 765-3263

**Carroll, Chariton, Johnson, Lafayette, Pettis, Ray, Saline:**  
Missouri Valley Community Action Agency - (660) 831-5331

**Lewis, Lincoln, Macon, Marion, Monroe, Montgomery, Pike, Ralls, Randolph, Shelby, St. Charles, and Warren:**  
North East Community Action Corporation - (573) 324-0120

**Adair, Clark, Knox, Schuyler, and Scotland:**  
Community Action Partnership North East Missouri - (660) 665-9855

**Douglas, Howell, Oregon, Ozark, Texas, and Wright:** Ozark Action, Inc. - (417) 256-6147

**Barry, Christian, Dade, Dallas, Greene, Lawrence, Polk, Stone, Taney, and Webster:**  
Ozarks Area Community Action Corporation - (417) 864-3460

**Butler, Carter, Dent, Reynolds, Ripley, Shannon, and Wayne:**  
South Central Missouri Community Action Agency - (800) 325-4633

**Jackson, Clay, and Platte:** Mid-America Assistance Coalition - (816) 768-8900

**Bates, Benton, Cass, Cedar, Henry, Hickory, Morgan, St. Clair, and Vernon:**  
West Central Missouri Community Action Agency - (660) 476-2185

**LOW INCOME HOUSEHOLD WATER ASSISTANCE PROGRAM  
SUPPLIER AGREEMENT  
BETWEEN  
MISSOURI DEPARTMENT OF SOCIAL SERVICES  
FAMILY SUPPORT DIVISION  
And  
WATER/WASTERWATER SUPPLIERS**

**1. Purpose**

1.1 This agreement, made by and between the Department of Social Services, Family Support Division (hereinafter referred to as the Department) and the Home Water/Wastewater Supplier stated below, (hereinafter referred to as the Supplier) shall be as follows:

\_\_\_\_\_  
(Name of Company)

1.2 Missouri’s Low Income Household Water Assistance Program (LIHWAP) is authorized under Section 553 Title V of Division H of the Consolidated Appropriations Act, 2021, Public Law No: 116-260. Consistent with legislative instructions, program requirements use existing processes, procedures, and policies currently in place to provide assistance to low-income households. In particular, Office of Community Services (OCS) has closely modeled the LIHWAP terms and conditions on assurances and requirements outlined in the Low Income Household Energy Assistance Act, 42 U.S.C. 8621 *et seq.*

1.3 This agreement shall govern the purchase of water/wastewater services from the Supplier on behalf of households eligible for LIHWAP. Funds awarded shall be used as part of an overall emergency effort to prevent, prepare for, and respond to the COVID-19 pandemic, with the public health focus of ensuring that low-income households have access to drinking water and wastewater services. The funds will be used to cover or reduce arrearages, rates, and fees associated with reconnection or preventions of disconnections of service, and rate reduction to eligible households for such services. This agreement is for the provision of water bill payments to assist low-income households with water and wastewater reconnection and ongoing services.

1.4 The parties acknowledge that this agreement and the services provided by the Supplier are governed by and subject to the federal and state laws and regulations in accordance with the LIHWAP supplemental terms and conditions.

**2. Definitions**

2.1 **Credit Balance** - any surplus of funds remaining on the account of an eligible customer created as the result of a LIHWAP payment to the supplier at the conclusion of the appropriate program period defined in the agreement.

2.2 **Eligible Customer** - a household that makes application for assistance under LIHWAP, is determined eligible for benefits by the Department or contractor, and is accepted by the Supplier as an active account.

2.3 **Payment** - a line of credit payment to the Supplier equal to the maximum subsidy per eligible customer as set forth in Attachment A of this agreement.

**3. Terms of Agreement/Modifications**

3.1 The agreement period shall be effective October 1, 2021 through September 30, 2023. This agreement shall not bind, nor purport to bind, the Department for any commitment in excess of the original agreement period. This agreement shall become effective upon signature by authorized representatives of the Supplier and the Department and shall apply to water/wastewater assistance to eligible customers under LIHWAP in accordance with the following program period, as established above.

- a. Water/Wastewater: home drinking water and wastewater consumed beginning on or after October 1<sup>st</sup> of each year and ending no later than the end of the first billing cycle for an eligible customer after September 30<sup>th</sup> of each year - not to extend past September 30, 2023.

3.2 Changes to this agreement must be made by a formal agreement amendment signed and approved by and between the duly authorized representative of the Supplier and the Department prior to the effective date of

such modification. No other document, including correspondence, e-mail, acts, or oral communications from any person, shall be used or construed as an amendment or modification to the agreement.

- 3.3 This document expresses the complete agreement of the parties. Performance of the agreement shall be governed solely by the specifications and requirements contained in the agreement. The exclusive venue for any litigation arising under this agreement shall be Cole County, Missouri. This agreement shall be interpreted in accordance with the laws of the State of Missouri.

#### 4. Responsibilities of the Parties

##### 4.1 The Department agrees to:

- a. Provide the Supplier with a weekly listing of eligible customers (Customer Eligibility Listing or CEL) who have designated the company as their primary water/wastewater supplier. These listings shall include at least the following data elements:
  1. Complete name of eligible customer;
  2. Complete address of eligible customer;
  3. Customer account number provided on the Supplier's billing information;
  4. Amount of payment the Department will make on behalf of each eligible customer whose name appears on the listing; and
  5. Social Security Number of the customer supplied by the Department.
- b. Secure from each eligible customer and from its agents or contractors, written authorization for the release of information concerning the eligible customer's account with the Supplier.

##### 4.2 The Supplier agrees to:

- a. Require any of its districts, regional or local companies who provide services to eligible customers in Missouri, to comply with all provisions of this agreement. The Supplier shall complete and submit to the Department Exhibit #1 – Supplier Information and the signed agreement the complete name and address of any sub-suppliers who will be involved under the terms of this agreement.
- b. As conditions for receiving payment for its eligible customers under Missouri's Low Income Household Water Assistance Program, the Supplier:
  1. Shall not discriminate with regard to the terms or conditions of the sale, availability of credit, or price of home water offered to eligible customers in relation to its other residential customers.
  2. Shall return Customer Eligibility Listings (CEL's) to the Department within **fifteen (15) calendar days** after they are received, indicating whether the LIHWAP payment to be made on behalf of the eligible customer can be accepted by the Supplier. If the Supplier notifies the Department that they cannot accept payment on behalf of a particular eligible customer for reasons other than those stipulated in this agreement, payment will automatically be made on behalf of the eligible customer. If the Supplier **fails to return** a CEL within a **thirty (30) calendar day** timeframe, **direct payments** will be made on behalf of **all customers** who appeared on said listing.
  3. Shall accept the LIHWAP payment to be made on behalf of an eligible customer; and not use any portion of the LIHWAP payment made on behalf of the eligible customer for reimbursement of fees charged by collection agencies.
  4. Shall credit, through normal billing process, the full amount of the LIHWAP pledge received to an eligible customer's account. The Supplier may apply any portion of the received LIHWAP pledge to an eligible customer's previous account balance, provided the pledge will continue/restore services for at least thirty (30) calendar days after the LIHWAP pledge is applied to the eligible customer's previous account balance.
  5. Should make an effort to offer eligible customers, on whose behalf the Department has made payment, a deferred payment plan for any balance due on their account that exceeds the amount made by the Department and consider continued provision of water and wastewater services to the eligible customer who maintains their deferred payment plan for the duration of this agreement.
  6. Shall provide water and wastewater services at least equivalent to the amount of the pledge made by the Department on behalf of the eligible customer. Services shall be restored or continued during the service period covered by the payment for at least thirty (30) calendar days from the date of the pledge made on behalf of the eligible customer.

7. Should consider waiving deposits, name change or late payment fees for an eligible customer for whom the Supplier agrees to accept a LIHWAP payment. Item 7.
8. Shall not transfer any portion of the LIHWAP payment made on behalf of an eligible customer to any other customer's account.
9. Should notify each eligible customer in writing of the amount of any credit balance remaining on their account because of the LIHWAP payment, no later than the end of the first billing cycle for the eligible customer after September 30<sup>th</sup> of each year. In the case of payments received after September 30<sup>th</sup>, notification of any credit balance must be made no later than the next regular billing cycle for the customer on whose behalf the LIHWAP payment is received.
10. Shall refund any LIHWAP credit balance remaining on an eligible customer's account to the Department and any remaining customer credit balance directly to the customer, when the customer voluntarily terminates service with the Supplier or leaves the Supplier's designated service area, no later than sixty (60) calendar days after their final billing statement or by the end of the program year (September 30<sup>th</sup>).
11. In the event the designated customer dies during the program coverage period and the credit balance on their account is not used by a surviving household member over the age of eighteen (18) at the same address, it will be refunded to the Department. Any credit balances that cannot be utilized under the terms of this agreement will be refunded to the Department no later than September 30<sup>th</sup> of each program year.
12. Refunds must include the following information: Customer name and address, date of LIHWAP payment to the Supplier, and reason for return.
13. Shall not accept the LIHWAP payment on behalf of customers with the following account status:
- a. Inactive Account: an account on which service was terminated and the Supplier does not agree to restore or continue service to this customer under the provisions of this agreement;
  - b. Commercial Account: an account identified by the Supplier via rate structures or other means as generally being utilized by a commercial business;
  - c. Not Our Customer: an account which the Supplier is unable to identify via existing records as being a customer of the company;
  - d. Invalid Account Number: an account which the Supplier is unable to identify via existing records the customer account number;
  - e. Needs Additional Payment: an account on which the Supplier needs additional funds to restore and continue services;
  - f. Negative Customer Response: an account which the Supplier is able to verify, but, the customer failed to call and make an appointment to restore services; or
14. Must utilize the identifying information below concerning eligible customers served when corresponding with the Department:
- Complete name of eligible customer (account holder);
  - Complete address of eligible customer;
  - Customer account number of eligible customer; and
  - Social Security Number of the customer supplied by the Department.

## 5. Payments

- 5.1 The Department agrees to provide payment to the Supplier within fifteen (15) calendar days for those customers on whose behalf the Supplier has agreed to accept payment.
- a. Failure to submit the CELs within the time frames set forth in this agreement may delay payment to the Supplier.
- 5.2 The Supplier is encouraged to participate in the Department's direct deposit program and to complete an Automatic Clearing House/Electronic Funds Transfer (ACH/EFT) application.
- 5.3 If funds for payment of service costs of eligible customers are not sufficient to permit the Department to reimburse the Supplier in accordance with the payment maximums specified in Attachment A, the Department will prorate payments to the Supplier on the basis of the total obligations for water and wastewater services costs of all eligible customers in Missouri and the amount of funding available to me

these obligations. The Department will utilize this procedure until all available funding for the payment of water and wastewater services costs of eligible customers has been expended.

## **6. Monitoring/Reporting**

6.1 The Department is required to perform a review of actual usage data of eligible customers served during the program year. The Department will provide a report to the Supplier at the end of the program year. The Supplier shall submit to the Department actual usage data for each eligible customer in each billing cycle or calendar month of the pertinent period set forth under the program period defined in this agreement. Actual usage data submitted shall include:

- a. The complete name and address of each eligible customer;
- b. The customer's account number;
- c. The Social Security Number of each customer;
- d. The amount of any credit balance remaining on the account of an eligible customer at the end of the first billing cycle for an eligible customer after September 30th of each year;
- e. The amount of an eligible customer's outstanding account balance at the time the Supplier agreed to accept the LIHWAP payment if the Supplier used the payment in accordance with this agreement;

## **7. Confidentiality**

- 7.1 The Supplier shall understand that all discussions with the Supplier and all information gained by the Supplier as a result of the Supplier's performance under this agreement shall be confidential. The contractor shall not release reports, documentation, or material prepared required by this agreement without the prior written consent of the Department.
- 7.2 The Department shall only use information provided by the Supplier about the account of an eligible customer for administering LIHWAP. The Department shall obtain the same agreement from any of its Suppliers.
- 7.3 The Supplier agrees not to use or disclose any information related to its eligible customers to any parties except the Department with all applicable state and federal laws dealing with privacy and confidentiality of information related to eligible customers of LIHWAP. This agreement shall immediately be declared null and void if the Supplier is determined to be out of compliance with privacy and confidentiality laws
- 7.4 The Supplier shall ensure that all persons in its employ who are authorized to have access to or use information obtained from the Department understand the conditions of this agreement. In the case of information obtained electronically or by using the web-based access, attest to such understanding in writing by signing a DSS Security Access and Confidentiality Agreement form. Availability of this information must be limited to employees with a "need to know". The Department shall deny access to information if the Supplier is determined to be out of compliance. The Department may declare this agreement null and void if the Supplier is determined to be out of compliance with the agreement.
- 7.5 The Supplier agrees to retain all books, records, and other documents relevant to this agreement for a minimum of five (5) years or until any litigation, claim, negotiation, audit, or other action involving the records that was initiated prior to the expiration of this five (5) year period has been completed. Upon request of the Department, the Supplier shall permit authorized representatives of the Department, and such other Federal or State agencies as may require such information, to have access to such records as may be necessary to confirm the Supplier's compliance with the provisions of this agreement.

## **8. Fraud Prevention and Reporting**

- 8.1 The Supplier shall report any financial fraud or abuse or misconduct in the administration of LIHWAP to the Department of Social Services (DSS), Division of Legal Services (DLS). The Supplier shall call 877-770-8055 or report by email at [DLS.ReportVendorFraud@dss.mo.gov](mailto:DLS.ReportVendorFraud@dss.mo.gov). Suppliers shall cooperate with all DLS investigations of suspected fraud or abuse or misconduct.
- 8.2 The Supplier may be prosecuted under applicable federal or state law or both for false claims, statements, or documents, or concealment of material fact.

## **9. Termination**

- 9.1 Termination of this agreement without cause may occur by either party terminating its duties under this agreement upon provision of thirty (30) calendar days written notice to the other, except that the duties of Section 4.2b 9 through 13, 5.3 and 6.1 shall survive. Additionally:

- a. It is understood and agreed upon that in the event funds or appropriation authority from local, state and federal sources are not obtained and continued at an aggregate level sufficient to allow for the purchase of the indicated quantity of services, as determined by the Department, the obligation of each party hereunder shall thereupon terminate immediately upon receipt of written notice from the Department;
- b. Either party may terminate this agreement immediately by written notice for cause related to the adequacy of performance. Any written notification shall be effective upon deposit in the mail; and
- c. The Supplier shall not incur new obligations for the terminated portion of the agreement after the effective date of the termination for cause. The Supplier shall cancel as many outstanding obligations as possible.

10. **Debarment Certification**

10.1 The Supplier, by signing the signature page of this original agreement and any amendment signature page(s), certifies that the Supplier is not presently debarred, suspended, proposed for debarment, declared ineligible, voluntarily excluded from participation, or otherwise excluded from or ineligible for participation under federal assistance programs. The Supplier should complete and return the attached certification regarding debarment, etc., Exhibit #2 with the agreement. The Supplier must satisfactorily complete this certification prior to award of this agreement.

11. **Business Compliance**

11.1 The Supplier must comply with the laws regarding conducting business in the State of Missouri. The Supplier certifies by signing the signature page of this original document and any amendment page(s) that the Supplier and any proposed subcontractors either are presently in compliance with such laws or shall comply with such laws prior to any resulting agreement. The Supplier shall provide documentation of compliance upon request by the Department. The compliance to conduct business in the state shall include, but not necessarily be limited to:

- a. Registration of business name (if applicable);
- b. Certificate of authority to transact business/certificate of good standing (if applicable);
- c. Taxes (e.g., city/county/state/federal);
- d. State and local certifications (e.g., professions/occupations/activities);
- e. Licenses and permits (e.g., city/county license, sales permits); and
- f. Insurance (e.g., worker's compensation/unemployment compensation).

11.2 The provider must complete and submit Exhibit #3, Registration of Business Name (if applicable) with the Missouri Secretary of State, prior to award of contract.

11.3 In the event the Supplier contracts with any other party (subcontractor) to carry out the terms of this agreement, the Supplier shall include in its contracts with any other party this agreement as an incorporation by reference.

This agreement and any attachments thereto set forth all promises, agreements, and understandings between the Department and the Supplier. In witness thereof, the Department and the Supplier hereby execute this agreement.

\_\_\_\_\_  
Authorized Representative of Supplier

\_\_\_\_\_  
Authorized Representative of the  
Department of Social Services

\_\_\_\_\_  
Date

\_\_\_\_\_  
Date

**EXHIBIT #1: SUPPLIER INFORMATION**

Item 7.

**PLEASE COMPLETE THE INFORMATION BELOW AND RETURN WITH THE SIGNED AGREEMENT AND EXHIBIT #2. THE DIVISION WILL COMPLETE THE LAST LINE AND RETURN WITH THE SUPPLIER COPY OF THE SIGNED AGREEMENT.**

*Please attach a complete listing of all your branch offices, including their names, address, telephone and fax numbers and current e-mail addresses.*

COMPANY NAME \_\_\_\_\_

COMPANY MAILING ADDRESS \_\_\_\_\_  
\_\_\_\_\_

CITY \_\_\_\_\_ STATE \_\_\_\_\_ ZIP CODE \_\_\_\_\_

COUNTY \_\_\_\_\_

TELEPHONE NUMBER (\_\_\_\_) \_\_\_\_\_

FAX NUMBER (\_\_\_\_) \_\_\_\_\_

E-MAIL ADDRESSES (Primary) \_\_\_\_\_

(Other) \_\_\_\_\_

(Other) \_\_\_\_\_

(Other) \_\_\_\_\_

(Other) \_\_\_\_\_

(Other) \_\_\_\_\_

Water and wastewater services \_\_\_\_\_

-----  
**For State Office Use Only:**

**Supplier Number Assigned:** \_\_\_\_\_

HOUSEHOLD SIZE	MONTHLY INCOME AMOUNTS
	0%-60% STATE MEDIAN INCOME (SMI)
1	\$0-2,211
2	\$0-2,891
3	\$0-3,571
4	\$0-4,252
5	\$0-4,932
6	\$0-5,612
7	\$0-5,740
8	\$0-5,868
9	\$0-5,996
10	\$0-6,124
11	\$0-6,252
12	\$0-6,380
13	\$0-6,508
14	\$0-6,636
15	\$0-6,764
16	\$0-6,892
17	\$0-7,020
18	\$0-7,148
19	\$0-7,276
20	\$0-7,404

<b>Benefit Amount</b>
<b>Not to exceed \$750.00</b>



**Exhibit 2 - Certification Regarding Debarment, Suspension, Ineligibility and Voluntary Exclusion  
Lower Tier Covered Transactions**

Item 7.

This certification is required by 2 CFR Part 180.

**(BEFORE COMPLETING CERTIFICATION, READ INSTRUCTIONS FOR CERTIFICATION)**

- (1) The prospective recipient of Federal assistance funds certifies, by submission of this proposal, that neither it nor its principals are presently debarred, suspended, proposed for debarment, declared ineligible, or voluntarily excluded from participation in this transaction by any Federal department or agency.
- (2) Where the prospective recipient of Federal assistance funds is unable to certify to any of the statements in this certification, such prospective participant shall attach an explanation to this proposal.

Company Name	DUNS #
Authorized Representative's Printed Name	Authorized Representative's Title
Authorized Representative's Signature	Date

**Instructions for Certification**

- 1. By signing and submitting this proposal, the prospective recipient of Federal assistance funds is providing the certification as set out below.
- 2. The certification in this clause is a material representation of fact upon which reliance was placed when this transaction was entered into. If it is later determined that the prospective recipient of Federal assistance funds knowingly rendered an erroneous certification, in addition to other remedies available to the Federal Government, the Department of Labor (DOL) may pursue available remedies, including suspension or debarment.
- 3. The prospective recipient of Federal assistance funds shall provide immediate written notice to the person to which this proposal is submitted if at any time the prospective recipient of Federal assistance funds learns that its certification was erroneous when submitted or has become erroneous by reason of changed circumstances.
- 4. The terms "covered transaction," "debarred," "suspended," "ineligible," "lower tier covered transaction," "participant," "person," "primary covered transaction," "principal," "proposal," and "voluntarily excluded," as used in this clause, have the meanings set out in the Definitions and Coverage sections of rules implementing Executive Order 12549. You may contact the person to which this proposal is submitted for assistance in obtaining a copy of those regulations.
- 5. The prospective recipient of Federal assistance funds agrees by submitting this proposal that, should the proposed covered transaction be entered into, it shall not knowingly enter into any lower tier covered transaction with a person who is debarred, suspended, declared ineligible, or voluntarily excluded from participation in this covered transaction, unless authorized by the DOL.
- 6. The prospective recipient of Federal assistance funds further agrees by submitting this proposal that it will include the clause titled "Certification Regarding Debarment, Suspension, Ineligibility and Voluntary Exclusion - Lower Tier Covered Transactions," without modification, in all lower tier covered transactions and in all solicitations for lower tier covered transactions.
- 7. A participant in a covered transaction may rely upon a certification of a prospective participant in a lower tier covered transaction that it is not debarred, suspended, ineligible, or voluntarily excluded from the covered transaction, unless it knows that the certification is erroneous. A participant may decide the method and frequency by which it determines the eligibility of its principals. Each participant may but is not required to check the List of Parties Excluded from Procurement or Nonprocurement Programs.
- 8. Nothing contained in the foregoing shall be construed to require establishment of a system of records in order to render in good faith the certification required by this clause. The knowledge and information of a participant is not required to exceed that which is normally possessed by a prudent person in the ordinary course of business dealings.
- 9. Except for transactions authorized under paragraph 5 of these instructions, if a participant in a covered transaction knowingly enters into a lower tier covered transaction with a person who is suspended, debarred, ineligible, or voluntary excluded from participation in this transaction, in addition to other remedies available to the Federal Government, the DOL may pursue available remedies, including suspension or debarment.

**EXHIBIT # 3:**

Item 7.

**Registration of Business Name (if applicable) with the Missouri Secretary of State:**

The vendor should indicate the vendor's charter number and company name with the Missouri Secretary of State. Additionally, the vendor should provide proof of the vendor's good standing status with the Missouri Secretary of State. If the vendor is exempt from registering with the Missouri Secretary of State pursuant to section 351.572, RSMo, identify the specific section of 351.572 RSMo, which supports the exemption.

<b>Charter Number (if applicable)</b>	<b>Company Name</b>
If exempt from registering with the Missouri Secretary of State pursuant to section 351.572 RSMo, identify the section of 351.572 to support the exemption:	

If your business entity is not registered, you may go to the link provided below to register:

[www.sos.mo.gov/fileonline](http://www.sos.mo.gov/fileonline)

If you believe your business entity is exempt from registering with the Secretary of State due to one of the specific exemptions contained in the Missouri Revised Statutes, please indicate in your response the specific exemption that applies to your business entity.

Below are the exemption sections of the Missouri Revised Statutes for the most popular business entity types:

1. General Business - section 351.572, RSMo, located at:  
<http://revisor.mo.gov/main/OneSection.aspx?section=351.572&bid=18804&hl=>
2. Limited Liability Company - section 347.163.5, RSMo, located at:  
<http://revisor.mo.gov/main/OneSection.aspx?section=347.163&bid=18500&hl=>
3. Limited Partnership - section 359.551.5, RSMo, located at:  
<http://revisor.mo.gov/main/OneSection.aspx?section=359.551&bid=19476&hl=>
4. Non-Profit - section 355.751.2, RSMo, located at:  
<http://revisor.mo.gov/main/OneSection.aspx?section=355.751&bid=19289&hl=>
5. Professional Corporation - section 356.231, RSMo, located at:  
<http://revisor.mo.gov/main/OneSection.aspx?section=356.231&bid=19340&hl=>

Note: Limited Liability Partnerships have no exemptions.

For questions regarding registration, contact the Missouri Secretary of State at:

[corporations@sos.mo.gov](mailto:corporations@sos.mo.gov) or (573) 751-4153 (toll free 866-223-6535)



## AGENDA ITEM ANALYSIS

Project/Issue Name: 21-R-48 A Resolution of the City Council of the City of Republic, Missouri, Appointing a Council Member for Ward 1.

Submitted By: Laura Burbridge, City Clerk

Date: October 19, 2021

### Issue Statement

The appointment of a Council Member for Ward 1.

### Discussion and/or Analysis

In the April 2021 municipal election, Brandon Self was elected as Council Member to represent Ward 1. Mr. Self has since moved out of Ward 1 and is not able to serve on the Council pursuant to Section 3.2(b) of the City's Charter. Therefore, a vacancy has been created on the City Council.

Pursuant to Section 3.6(c) of the Charter, " A vacancy in the Council shall be filled for the remainder of the expired term, if any, at the next regular municipal election, but the Mayor with the advice and consent of the Council may fill the vacancy until the person elected to serve the remainder of the unexpired term takes office."

This vacancy has been posted by the City and applications have been accepted from residents of Ward 1 who are interested in serving on the City Council. The Mayor has also interviewed the applicants.

**A RESOLUTION OF THE CITY COUNCIL OF THE CITY OF REPUBLIC, MISSOURI, APPOINTING A COUNCIL MEMBER FOR WARD 1**

**WHEREAS**, the City of Republic, Missouri, (herein called the "City") is a municipal corporation and Charter City located in Greene County, Missouri, being duly created, organized and existing under the laws of the State of Missouri; and

**WHEREAS**, Brandon Self was elected as a Council Member for Ward 1 at the municipal election held on April 6, 2021, but is unable to serve because he is no longer a resident of Ward 1 and, therefore, a vacancy has occurred on the City Council for Ward 1; and

**WHEREAS**, the City's Charter provides under Section 3.6, if a vacancy of the Council occurs, it shall be filled for the remainder of the unexpired term, if any, at the next regular municipal election, but the Mayor with the advice and consent of the Council may fill the vacancy until the person elected to serve the remainder of the unexpired term takes office.

**NOW, THEREFORE, BE IT RESOLVED BY THE CITY COUNCIL OF THE CITY OF REPUBLIC, MISSOURI, AS FOLLOWS:**

- Section 1. That \_\_\_\_\_, with the advice and consent of the Council, is appointed as a Council Member for Ward 1 pursuant to Section 3.6(c) of the Charter.
- Section 2. That the individual appointed shall be subject to the same duties and qualifications as would be required of any Council Member elected.
- Section 3. This Resolution shall become effective on and after the date of passage and approval.

**PASSED AND APPROVED** at a regular meeting of the City Council of the City of Republic, Missouri, this 19<sup>th</sup> day of October 2021.

\_\_\_\_\_  
Matt Russell, Mayor

Attest:

\_\_\_\_\_

Laura Burbridge, City Clerk

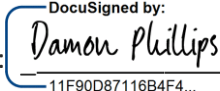
Approved as to Form:  10/15/2021, Damon Phillips, City Attorney  
11F90D87116B4F4...

Final Passage and Vote: \_\_\_\_\_



## AGENDA ITEM ANALYSIS

Project/Issue Name: 21-66 An Ordinance of the City Council of the City of Republic, Missouri, Amending Title IV, Land Use, Chapter 405, Zoning Regulations, Article V, Height and Area Requirements, Exceptions, and Modifications.

Submitted By: Chris Tabor, Principal Planner of BUILDS Department

Date: October 19, 2021

### Issue Statement

Consideration to approve Amendments to Chapter 405 Article V "Height and Area Requirements, Exceptions, and Modifications".

### Discussion and/or Analysis

The City of Republic is requesting Amendments to Chapter 405 Article V – specifically to Sections 405.540 and 405.545, to provide clarity to existing regulations and update building height restrictions for multi-family structures.

The purpose of article five is to regulate parcels as they relate to the various zoning districts that the City of Republic has adopted. Section 405.540 consists of a chart that displays those zoning districts and conveys how various aspects of parcels are treated for each. Examples of lot attributes include, but are not limited to, setbacks for various yards on a lot, lot width/depth/frontage requirements, and lot density. Accompanying the chart is Section 405.545, which is a list of exceptions. Use of the chart necessitates bouncing back and forth between the two sections to understand the ordinance.

This amendment reduces the list of exceptions by adding them into the chart, itself, when possible and removing those which are redundant or outdated altogether.

### **Change in Maximum Building Height**

The Amendment also removes the cap on maximum building height for residential districts. Previously, all residential zoning districts capped building height at three stories. Research into the topic has led Staff to understand that the placement of the limit was originally related to concerns that the Fire Department would not be able to adequately serve buildings beyond the three stories. Staff has concluded that these concerns are now mitigated by regulations within the adopted International Fire Code (IFC). The IFC places requirements on the design and build of structures regarding fire safety. In this case, sprinkling is required for residential buildings above eleven meters or, roughly, three stories.

### Recommended Action

Staff recommends the approval of the referenced Amendment.

**AN ORDINANCE OF THE CITY COUNCIL OF THE CITY OF REPUBLIC, MISSOURI, AMENDING TITLE IV, LAND USE, CHAPTER 405, ZONING REGULATIONS, ARTICLE V, HEIGHT AND AREA REQUIREMENTS, EXCEPTIONS, AND MODIFICATIONS**

*WHEREAS*, the City of Republic, Missouri, (herein called the “City” or “Republic”) is a municipal corporation and Charter City located in Greene County, Missouri, being duly created, organized, and existing under the laws of the State of Missouri; and

*WHEREAS*, the BUILDS Staff is proposing an amendment to Chapter 405-Article V “Height and Area Requirements, Exceptions, and Modifications” at Art. 405.540 and Art. 405.545, in order to make more clear the requirements described therein and to revise said requirements to conform with currently applicable standards, as described in the attached Exhibit 1; and

*WHEREAS*, the City did submit said proposed amendment to the Planning and Zoning Commission, which did set October 12, 2021, as the date a public hearing would be held on such proposed amendment; and

*WHEREAS*, a notice of the time and date of the public hearing was given by publication in The Greene County Commonwealth, a newspaper of general circulation in the City, such notice being at least 15 days before the date set for public hearing; and

*WHEREAS*, a public hearing was conducted by the Planning and Zoning Commission on October 12, 2021, after which the Commission rendered written findings of fact on the proposed amendment; and thereafter, submitted the same together with its recommendations, to the Council; and

*WHEREAS*, the Planning and Zoning Commission, by a vote of 6 Ayes to 0 Nays, recommended approval of such proposed amendment; and

*WHEREAS*, the proposed amendment was submitted to City Council at its regular meeting on October 19, 2021, after which the City Council did proceed to vote to adopt said amendment.

***NOW, THEREFORE, BE IT ORDAINED BY THE CITY COUNCIL OF THE CITY OF REPUBLIC, MISSOURI, AS FOLLOWS:***

Section 1. The amendment to Chapter 405-Article V “Height and Area Requirements, Exceptions, and Modifications” at Art. 405.540 and Art. 405.545, as described in attached Exhibit 1 is hereby approved and adopted by Council.

Section 2. The whereas clauses are hereby specifically incorporated herein by reference.

Section 3. This Ordinance shall take effect and be in force from and after its passage as provided by law.

***PASSED AND APPROVED*** at a regular meeting of the City Council of the City of Republic, Missouri, this \_\_\_\_ day of \_\_\_\_\_ 2021.

BILL NO. 21-66

ORDINANCE NO. 21-

\_\_\_\_\_  
Matt Russell, Mayor

Attest:

\_\_\_\_\_  
Laura Burbridge, City Clerk

DocuSigned by:  
*Damon Phillips*  
11F90D87116B4F4...

10/10/2021

Approved as to Form: \_\_\_\_\_, Damon Phillips,  
City Attorney

Final Passage and Vote: \_\_\_\_\_

**405.540 Height And Area Regulations Established -- Chart**

The required height and area regulations are established and shown on the following chart which is part of Article V.

**CITY OF REPUBLIC HEIGHT AND AREA REGULATIONS CHART**

	AG	R-1L	R-1M	R-1H	R1-MH	R-1Z	R-2	R-3	C-1	C-2	<u>C-3</u>	M-1	M-2
Min. Lot Size	3 acres	12,000 s.f.	9,000 s.f.	7,000 s.f.	6,000 s.f.	5,000 s.f.	10,000 s.f.	2,500 s.f. <sup>(44)</sup>	--	--	--	--	--
Front Setback	25'	25'	25'	25'	25'	25'	25'	<del>25'</del> <sup>(4)</sup> 15'	15' (4)	15' (4)	<u>15'</u>	15' (4)	15' (4)
Rear Setback	25'	25'	25'	25'	25'	25'	25'	<del>25'</del> 15'	15' (E6)	15' (E6)	<u>15'</u> (E)	15' (G7)	30' (G7)
Side Street Setback at an Intersection of two Collector Class Streets or Greater	25'	25' <sup>(42)</sup>	25' <sup>(42)</sup>	25' <sup>(42)</sup>	25'	25'	25'	<del>25'</del> <sup>(4)</sup> 15'	15'	15'	<u>15'</u>	15'	15'
Side Street Setback at an Intersection of Local and Collector Class Streets	<u>20'</u>	<u>20'</u>	<u>20'</u>	<u>20'</u>	<u>25'</u>	<u>25'</u>	<u>25'</u>	<u>15'</u>	<u>15'</u>	<u>15'</u>	<u>15'</u>	<u>15'</u>	<u>15'</u>
Side Street Setback at an Intersection of Local and	<u>15'</u>	<u>15'</u>	<u>15'</u>	<u>15'</u>	<u>25'</u>	<u>25'</u>	<u>25'</u>	<u>15'</u>	<u>15'</u>	<u>15'</u>	<u>15'</u>	<u>15'</u>	<u>15'</u>



<b>Local Class Streets.</b>														
Interior Side Yard Setback	6'	6' <sup>(F)</sup>	6' <sup>(F)</sup>	6' <sup>(F)</sup>	6' <sup>(F)</sup>	0 <sup>(D)</sup>	6'	15' <sup>(E)</sup>	6' <sup>(E)</sup>	6' <sup>(E)</sup>	<u>6'</u> <sup>(E)</sup>	15' <sup>(G)</sup>	15' <sup>(G)</sup>	
Min. Lot Width	100'	100'	80'	70'	60'	45'	85'	70'	--	--	--	--	--	
Min. Cul-de-sac Lot Width	60'	80' <sup>(J)</sup>	70' <sup>(J)</sup>	60' <sup>(J)</sup>	40' <sup>(J)</sup>	40' <sup>(J)</sup>	80' <sup>(J)</sup>	60' <sup>(J)</sup>	--	--	--	--	--	
Min. Lot Depth	200'	110'	100'	90'	80'	100'	100'	100'	--	--	--	--	--	
Max. Lot Coverage	--	--	--	--	--	--	--	80%	90%	90%	<u>90%</u>	90%	90%	
<b>Max Density (Lots per acre)</b>	<b><u>0.33</u></b>	<b><u>3.63</u></b>	<b><u>4.84</u></b>	<b><u>6.22</u></b>	<b><u>7.26</u></b>	<b><u>8.71</u></b>	<b><u>4.36</u></b>	<b><u>17.42</u></b>	--	--	--	--	--	
Min. Distance Between Structures	--	--	--	--	--	--	--	15'	--	--	--	--	--	
Max. Building Height	--	<del>3</del> stories <sup>f</sup>	<del>3</del> stories <sup>f</sup>	<del>3</del> stories <sup>f</sup>	<del>3</del> stories <sup>f</sup>	<del>3</del> stories <sup>f</sup>	<del>3</del> stories <sup>f</sup>	<del>3</del> stories <sup>f</sup>	<del>(H)</del>	<del>(H)</del>	<del>(H)</del>	<del>(H)</del>	<del>(H)</del>	

**NOTES:** The coordinating notes (subscript 1-12) concerning this table are contained in Section 405.545: Height and Area Exceptions and Conditions.

**405.545 Height And Area Exceptions And Conditions**

- A. ~~The minimum front yard setback established in Section 405.540 shall apply except:~~
  1. ~~Where a structure or dwelling is to be constructed on a lot or parcel of land that is within one hundred (100) feet of an existing structure or dwelling unit on both sides, the minimum front yard setback shall be an average of the two (2) closest front corners of the adjacent structures; or Where a structure or dwelling is to be constructed on a lot or parcel of land that is within one hundred (100) feet of an existing building on one (1) side only, such dwelling or structure may be constructed as close to the street as the existing adjacent building, with exception to a corner lot, in which the exception shall not apply.~~
- B. ~~(Reserved)~~
- C. ~~The front yard and side street setback can be reduced to fifteen (15) feet when off street parking is provided in the rear of the main structure or dwelling unit(s).~~
- D. ~~The dwelling unit shall be placed on one (1) interior side property line with a zero (0) setback and the dwelling unit setback on the other interior side property line shall be a minimum of ten (10) feet, excluding the connecting elements such as fences, walls and trellises, but including covered porches,~~

- patios and storage spaces which are part of the principal structure. Non-zero lot line dwelling units shall comply with the interior side yard setbacks of the appropriate single-family residential district.
- E. ~~No building shall exceed three (3) stories above grade. Upper story (third (3rd) story) windows shall not face onto an adjacent property owner's private space if within a less intensive zoning district, unless a setback of fifty (50) feet is provided and a vegetative buffer is provided in accordance with Section 405.900(C) Option 4.~~
- F. The minimum interior side or rear yard setback shall be as established in Section **405.540** unless **the premises is located adjacent to a residential zoning district, in which case the minimum rear yard and side yard setback shall each be twenty-five (25) feet.:**
1. ~~The structure is part of a planned commercial complex or center, in which case the setback shall not apply; or~~
  2. ~~The premises is located adjacent to a residential zoning district, in which case the minimum side yard setback shall be twenty five (25) feet.~~
- G. The minimum interior side or rear yard setback shall be as established in Section **405.540** unless the premises is located adjacent to a residential zoning district, in which case the minimum **rear yard and** side yard setback shall **each** be thirty-five (35) feet in a "M-1" District; and fifty (50) feet in a "M-2" District.
- H. No maximum building height unless the structure is adjacent to a single-family residential district, in which case the height of the structure shall remain below a forty-five degree (45°) bulk plane as measured from the boundary of the adjacent residential district.
- I. ~~The minimum interior side yard setback shall not apply to parcel combinations or parcels where residential structures are constructed across a common property line, in which ownership of both lots are the same and the possibility of future subdivision is eliminated. Parcels in which residential structures are proposed for construction across common property lines must comply with the City's Subdivision Regulations.~~
- J. The minimum lot width on a cul-de-sac shall be measured across the front of the lot at the radius of the twenty-five (25) feet setback.
- K. ~~The maximum density allowable may be increased in accordance with Section **405.140(E)** — Request for an increase in density.~~
- L. ~~For corner lots at the intersection of two local class thoroughfares, the side street setback shall be fifteen (15) feet. For corner lots at the intersection of a local class thoroughfare with a collector class thoroughfare, the side street setback shall be twenty (20) feet. For all other intersections, the side street setback shall be twenty-five (25) feet.~~

# Findings of Fact

Date of Hearing:

10/12/2021

Time:

6:00PM

Type of Application:

Code Amendment

Name of Applicant:

City of Republic

Location:

City Council Chambers

Based upon the facts presented during the course of this hearing, I have found that the application is generally:

- Conforming to the City's adopted Land Use Plan  Yes  No
- Conforming to the City's adopted Transportation Plan  Yes  No
- Conforming to other adopted plans of the City (i.e. water, wastewater, parks, etc.)  Yes  No
- Compatible with surrounding land uses  Yes  No
- Able to be adequately served by municipal infrastructure  Yes  No
- Aligned with the purposes of RSMo. 89.040  Yes  No

Statement of Relevant Facts Found:

Q Evidence Presented against Changes

Based on these findings, I have concluded to recommend the application to the City Council for:

Approval  Denial

Commissioner Name:

Commissioner Signature:

Brandon Andrews

Date:

10/12/2021

# Findings of Fact

Date of Hearing:

10/12/2021

Time:

6:00PM

Type of Application:

Code Amendment

Name of Applicant:

City of Republic

Location:

City Council Chambers

Based upon the facts presented during the course of this hearing, I have found that the application is generally:

- Conforming to the City's adopted Land Use Plan  Yes  No
- Conforming to the City's adopted Transportation Plan  Yes  No
- Conforming to other adopted plans of the City (i.e. water, wastewater, parks, etc.)  Yes  No
- Compatible with surrounding land uses  Yes  No
- Able to be adequately served by municipal infrastructure  Yes  No
- Aligned with the purposes of RSMo. 89.040  Yes  No

### Statement of Relevant Facts Found:

Developers have expressed interest in apartment buildings higher than 3 stories  
C-3 wasn't on original ordinance. It is now added.

Based on these findings, I have concluded to recommend the application to the City Council for:

Approval  Denial

Commissioner Name:

Kevin Hahn

Commissioner Signature:



Date:

10/12/21

# Findings of Fact

Date of Hearing:

10/12/2021

Time:

6:00PM

Type of Application:

Code Amendment

Name of Applicant:

City of Republic

Location:

City Council Chambers

**Based upon the facts presented during the course of this hearing, I have found that the application is generally:**

- Conforming to the City's adopted Land Use Plan  Yes  No
- Conforming to the City's adopted Transportation Plan  Yes  No
- Conforming to other adopted plans of the City (i.e. water, wastewater, parks, etc.)  Yes  No
- Compatible with surrounding land uses  Yes  No
- Able to be adequately served by municipal infrastructure  Yes  No
- Aligned with the purposes of RSMo. 89.040  Yes  No

**Statement of Relevant Facts Found:**

Removal of Max height  
Mod. location of Chart to include conditions + exceptions for better visibility

**Based on these findings, I have concluded to recommend the application to the City Council for:**

Approval  Denial

Commissioner Name:

Brian Debraun

Commissioner Signature:

*Brian Debraun*

Date:

10-12-21

# Findings of Fact

Date of Hearing:  Time:  Type of Application:

Name of Applicant:  Location:

**Based upon the facts presented during the course of this hearing, I have found that the application is generally:**

- Conforming to the City's adopted Land Use Plan  Yes  No
- Conforming to the City's adopted Transportation Plan  Yes  No
- Conforming to other adopted plans of the City (i.e. water, wastewater, parks, etc.)  Yes  No
- Compatible with surrounding land uses  Yes  No
- Able to be adequately served by municipal infrastructure  Yes  No
- Aligned with the purposes of RSMo. 89.040  Yes  No

**Statement of Relevant Facts Found:**

**Based on these findings, I have concluded to recommend the application to the City Council for:**  Approval  Denial

Commissioner Name:  Commissioner Signature:  Date:

# Findings of Fact

Date of Hearing:  Time:  Type of Application:

Name of Applicant:  Location:

Based upon the facts presented during the course of this hearing, I have found that the application is generally:

- Conforming to the City's adopted Land Use Plan  Yes  No
- Conforming to the City's adopted Transportation Plan  Yes  No
- Conforming to other adopted plans of the City (i.e. water, wastewater, parks, etc.)  Yes  No
- Compatible with surrounding land uses  Yes  No
- Able to be adequately served by municipal infrastructure  Yes  No
- Aligned with the purposes of RSMo. 89.040  Yes  No

Statement of Relevant Facts Found:

Based on these findings, I have concluded to recommend the application to the City Council for:  Approval  Denial

Commissioner Name:  Commissioner Signature:  Date:

# Findings of Fact

Date of Hearing:

10/12/2021

Time:

6:00PM

Type of Application:

Code Amendment

Name of Applicant:

City of Republic

Location:

City Council Chambers

**Based upon the facts presented during the course of this hearing, I have found that the application is generally:**

- Conforming to the City's adopted Land Use Plan       Yes       No
- Conforming to the City's adopted Transportation Plan       Yes       No
- Conforming to other adopted plans of the City (i.e. water, wastewater, parks, etc.)       Yes       No
- Compatible with surrounding land uses       Yes       No
- Able to be adequately served by municipal infrastructure       Yes       No
- Aligned with the purposes of RSMo. 89.040       Yes       No

**Statement of Relevant Facts Found:**

**Based on these findings, I have concluded to recommend the application to the City Council for:**

Approval       Denial

Commissioner Name:

Darran Campbell

Commissioner Signature:

Darran Campbell

Date:

10-12-21





## AGENDA ITEM ANALYSIS

Project/Issue Name: 21-67 An Ordinance of the City Council of the City of Republic, Missouri, Amending Title VI, Business Occupation.  
Submitted By: Chris Tabor, Principal Planner of BUILDS Department  
Date: October 19, 2021

### Issue Statement

Consideration to approve Amendments to Title VI “Business and Occupation”

### Discussion and/or Analysis

The City of Republic is requesting Amendments to Title VI “Business and Occupation”, specifically Chapters 600, 605, 610, 615, 630, and 631, in order to make general updates that brings the ordinance into conformance with the processes currently practiced by the City.

Title VI lays out how the City’s licensing regime ought conduct itself. The specific areas covered by the ordinance are: licensing of liquor, licensing of businesses, licensing of solicitation activities, licensing of massage establishments, cigarette taxing, licensing of pawnshops and pawnbrokers, regulations pertaining to the purchase of precious metals or jewelry by a business, and medical marijuana facilities.

The responsibility of licensing was formerly undertaken by the City Clerk but currently falls under the purview of the BUILDS Department. This change occurred in 2018 but is not reflected by the existing ordinance. A great many of the alterations in the amendment simply denote this: simply substituting “BUILDS Department Administrator or their designee” for “City Clerk.” Other changes consist of merging the ordinance with current practices for material collection and application submission and review.

### Recommended Action

Staff recommends the approval of the referenced Amendment.

**AN ORDINANCE OF THE CITY COUNCIL OF THE CITY OF REPUBLIC, MISSOURI, AMENDING TITLE VI, BUSINESS OCCUPATION**

**WHEREAS**, the City of Republic, Missouri, (herein called the "City" or "Republic") is a municipal corporation and Charter City located in Greene County, Missouri, being duly created, organized, and existing under the laws of the State of Missouri; and

**WHEREAS**, the City of Republic strives to continually review and revise the Municipal Code of the City of Republic, Missouri to enhance clarity and simplify needless complexity or ambiguity in its language; and

**WHEREAS**, the City of Republic revised the process of business licensing in 2018, removing it from the office of the City Clerk into the BUILDS Department to create a "one stop shop" for businesses and building.

**NOW THEREFORE, BE IT ORDAINED BY THE COUNCIL OF THE CITY OF REPUBLIC, IN THE STATE OF MISSOURI, AS FOLLOWS:**

Section 1: The amendments to Title VI "Business Occupation" as described in attached Exhibit 1 is hereby approved and adopted by Council.

Section 2: The whereas clauses are hereby specifically incorporated herein by reference.

Section 3: This Ordinance shall take effect and be in force from and after its passage as provided by law.

**PASSED AND APPROVED** at a regular meeting of the City Council of the City of Republic, Missouri, this\_\_day of November 2021.

\_\_\_\_\_  
Matt Russell, Mayor

ATTEST:

\_\_\_\_\_  
Laura Burbridge, City Clerk

DocuSigned by:  
*Damon Phillips* 10/14/2021  
11E90D87116B4F4

Approved as to Form \_\_\_\_\_, Damon Phillips, City Attorney

Final Passage and Vote: \_\_\_\_\_

## Exhibit 1

## 600.030 License Regulations

- A. *Package Sales, Limitations.* No license shall be issued for the sale of intoxicating liquor in the original package, not to be consumed upon the premises where sold, except to a person engaged in, and to be used in connection with, the operation of one (1) or more of the following businesses: a drug store, a cigar and tobacco store, a grocery store, a general merchandise store, a confectionery or delicatessen store, nor to any such person who does not have and keep in his/her store a stock of goods having a value according to invoices of at least one thousand dollars (\$1,000.00), exclusive of fixtures and intoxicating liquors. Under such license, no intoxicating liquor shall be consumed on the premises where sold nor shall any original package be opened on the premises of the vendor except as otherwise provided in this Chapter or law.
- B. *Newly-Opened Restaurant Bars Or Amusement Places.*
1. Any new restaurant bar having been in operation for less than ninety (90) days may be issued a temporary license to sell intoxicating liquor by the drink at retail for consumption on the premises between the hours of 9:00 A.M. and Midnight on Sunday for a period not to exceed ninety (90) days if the restaurant bar can show a projection of annual business from prepared meals or food consumed on the premises of at least fifty percent (50%) of the total gross income of the restaurant bar for the year or can show a projection of annual business from prepared meals or food consumed on the premises which would exceed not less than two hundred thousand dollars (\$200,000.00). The license fee shall be prorated for the period of the temporary license based on the cost of the annual license for the establishment.
  2. Any new amusement place having been in operation for less than ninety (90) days may be issued a temporary license to sell intoxicating liquor by the drink at retail for consumption on the premises between the hours of 9:00 A.M. and Midnight on Sunday for a period not to exceed ninety (90) days if the amusement place can show a projection of gross receipts of at least one hundred thousand dollars (\$100,000.00) of which at least fifty thousand dollars (\$50,000.00) of such gross receipts are in non-alcoholic sales for the first (1st) year of operation. The license fee shall be prorated for the period of the temporary license based on the cost of the annual license for the establishment.
  3. Any new resort/restaurant having been in operation for less than ninety (90) days may be issued a temporary license, for a period not to exceed ninety (90) days, to sell intoxicating liquor by the drink at retail for consumption on the premises between the hours of 6:00 A.M. and 1:30 A.M. on weekdays and between the hours of 6:00 A.M. on Saturdays until 1:30 A.M. on Sundays. No intoxicating liquor may be sold on Sundays except in accordance with the provisions of Section 600.020(C) of this Code of Ordinances and except in accordance with the provisions of Subsection (B)(1) hereof. No such temporary license shall be issued except for an establishment having at least thirty (30) rooms for the overnight accommodation of transient guests, having a restaurant or similar facility on the premises, at least sixty percent (60%) of the gross income of which is derived from the sale of prepared meals or food; or which is a restaurant provided with special space and accommodations where, in consideration of payment, food, without lodging, is habitually furnished to travelers and customers, and which restaurant

can show a projection of annual gross receipts of not less than seventy-five thousand dollars (\$75,000.00) per year, with at least fifty thousand dollars (\$50,000.00) of such gross receipts from non-alcoholic sales; or which is a seasonal resort restaurant as defined and with food sales as established in Subsection (2) of Section 311.095, RSMo.

C. *Temporary Permit For Sale By Drink — Certain Organizations.*

1. The ~~City Clerk~~ **BUILDS Department Administrator or their designee** may issue a permit for the sale of intoxicating liquor for consumption on premises where sold to any church, school, civic, service, fraternal, veteran, political or charitable club or organization for sale at a picnic, bazaar, fair or similar gathering. The permit shall be issued only for the day or days named therein and it shall not authorize the sale of intoxicating liquor for more than seven (7) days by any such club or organization.
2. If the event will be held on a Sunday, the permit shall authorize the sale of intoxicating liquor on that day beginning at 9:00 A.M.
3. At the same time that an applicant applies for a permit under the provisions of this Subsection, the applicant shall notify the Director of Revenue of the holding of the event by certified mail and by such notification shall accept responsibility for the collection and payment of any applicable sales tax.
4. No provision of law or rule or regulation of the City shall be interpreted as preventing any wholesaler or distributor from providing customary storage, cooling or dispensing equipment for use by the permit holder at such picnic, bazaar, fair or similar gathering.

D. *Operating Hours, Days.*

1. No licensee or any employee of such licensee shall sell, give away or otherwise dispose of, or allow the same to be done, on or about the premises, any intoxicating liquor in any quantity between the hours of 1:30 A.M. and 6:00 A.M. on weekdays and between the hours of 1:30 A.M. on Sunday and 6:00 A.M. on Monday, except as otherwise authorized and licensed for Sunday sales. Any person licensed to sell intoxicating liquor by the drink shall keep a closed place during the aforementioned prohibited times.
2. When January first (1st), March seventeenth (17th), July fourth (4th) or December thirty-first (31st) falls on Sunday and on the Sundays prior to Memorial Day and Labor Day and on the Sunday on which the national championship game of the National Football League is played, commonly known as "Super Bowl Sunday", any person having a license to sell intoxicating liquor by the drink may be open for business and sell intoxicating liquor by the drink under the provisions of his/her license on that day from the time and until the time which would be lawful on another day of the week, notwithstanding any provisions of this Chapter to the contrary.

E. *General License Regulations.*

1. Each license issued hereunder shall be conspicuously posted on the premises for which the license has been issued.
2. A separate license shall be required for each place of business. Every license issued under the provisions of this Chapter shall particularly describe the premises at which intoxicating liquor may be sold thereunder, and such license shall not be deemed to authorize or permit the sale of intoxicating liquor at any place other than that described therein.
3. No license issued under this Chapter shall be transferable or assignable except as herein provided. In the event of the death of the licensee, the widow or widower

or the next of kin of such deceased licensee, who shall meet the other requirements of this Chapter, may make application and the ~~Clerk~~**BUILDS Department Administrator or their designee** may transfer such license to permit the operation of the business of the deceased for the remainder of the period for which a license fee has been paid by the deceased. Whenever one (1) or more members of a partnership withdraws from the partnership, the ~~Clerk~~**BUILDS Department Administrator or their Designee**, upon being requested, shall permit the remaining partner or partners originally licensed, to continue to operate for the remainder of the period for which the license fee has been paid, without obtaining a new license.

4. In the event any licensee desires to change the location of his/her place of business in the City, it shall be necessary for him/her to file an application in the same manner as herein provided for an original application, except that no additional fee shall be charged and the amended license, describing the new location, shall be issued immediately upon the approval of the application by the Council. Any change of location of the enterprise prior to issuance of such an amended license shall constitute a violation of this Section.
- F. *Druggists May Sell And Physicians Prescribe Liquor.* Any druggist may have in his/her possession intoxicating liquor purchased by him/her from a licensed vendor under a license pursuant to State law, or intoxicating liquor lawfully acquired at the place of acquisition and legally transported into this State, and lawfully inspected, gauged and labeled as provided by State law; such intoxicating liquor to be used in connection with the business of a druggist in compounding medicines or as a solvent or preservative; provided, that nothing in this Chapter shall prevent a regularly licensed druggist, after he/she procures a license therefor, from selling intoxicating liquor in the original package, but not to be drunk or the packages opened on the premises where sold; and provided further, that nothing in this Chapter shall be construed as limiting the right of a physician to prescribe intoxicating liquor in accordance with his/her professional judgment for any patient at any time, or prevent a druggist from selling intoxicating liquor to a person on prescription from a regularly licensed physician as above provided.
- G. *Certain Persons May Not Be Supplied Intoxicating Liquors.*
1. No licensee or his employee shall sell or supply intoxicating liquor, or permit the same to be sold or supplied, to a habitual drunkard or to any person who is under or apparently under the influence of intoxicating liquor. Intoxicating liquor shall not be given, sold or otherwise supplied to any person under the age of twenty-one (21) years, but this shall not apply to the supplying of intoxicating liquor to a person under said age for medicinal purposes only or to the administering of such intoxicating liquor to any person by a duly licensed physician. No person under the age of twenty-one (21) years shall sell, or assist in the sale or dispensing of intoxicating liquor except as may be authorized under Section 311.300, RSMo.
  2. These provisions shall not apply to premises where substantial quantity of foods are served, premises used primarily as a bowling alley or premises with licenses prescribed in Section 311.480, RSMo. For the purpose of this paragraph, "*substantial quantities of food*" shall mean the amount of prepared meals and food wherefrom at least fifty percent (50%) of the gross income of any establishment has been derived during the three (3) most recent months preceding. Persons under the age of twenty-one (21) are restricted from entering premises selling intoxicating liquors, etc., except that a person age sixteen (16) through twenty (20) years may be on said premises if accompanied by a legal guardian, parent or

spouse over the age of twenty-one (21) years. It shall be unlawful for any licensee holding a sales-by-drink license for intoxicating liquor or beer, or his employee, agent or servant, to either directly or indirectly suffer or allow a person under the age of twenty-one (21) years to enter the premises of said licensee, except that a person age sixteen (16) through twenty (20) years may be on said premises if accompanied by a legal guardian, parent or spouse over the age of twenty-one (21) years.

H. *Prohibiting The Use Of Alcoholic Beverages And Drugs By Any Minor At Open House Parties.*

1. No person who is the owner in possession, a tenant or subtenant, or has temporary charge of any residence or premises shall allow an open house party to take place at the residence or premises if any alcoholic beverage or drug is possessed or consumed at the residence or premises by any minor where the person knew or reasonably should have known that any alcoholic beverage or drug was in the possession of or being consumed by a minor at the residence or premises and where the person failed to take reasonable steps to prevent the possession or consumption of the alcoholic beverage or drug at the residence or premises.

The provisions of this Section shall not apply to:

- a. The consumption, use or possession of a drug by a minor pursuant to a lawful prescription for each drug.
- b. Religious observance or prescribed medical treatments.
- c. The possession by a minor of alcoholic beverages or lawfully prescribed drugs incidental to the lawful employment of such minor.

2. The following definitions shall be used for the provisions of this Section:

**ADULT**

Person seventeen (17) years of age or older.

**ALCOHOLIC BEVERAGE**

Any alcoholic liquor as defined now and hereafter by the Revised Statutes of Missouri (RSMo). Currently, "alcoholic liquor" is defined by Section 311.020, RSMo.

**CONTROL**

Any form of authority, regulation, responsibility or dominion, including a possessory right.

**DRUG**

A controlled substance as defined and described now or hereafter by the Revised States of Missouri. Currently "controlled substances" are defined and described by Sections 195.005 — 195.425, RSMo.

**MINOR**

A person not legally permitted by reason of age to possess, consume or purchase alcoholic liquor as described now or hereafter by the Revised Statutes of Missouri.

#### OPEN HOUSE PARTY

A social gathering at a residence or premises of persons in addition to the owner or those with rights of possession or their immediate family members at which one (1) or more minors are present.

#### RESIDENCE OR PREMISES

A motel room, hotel room, home, apartment, condominium or other dwelling unit, including the curtilage of a dwelling unit, or a hall, meeting room or other place of assembly, whether occupied as a dwelling or specifically for social functions and whether owned, leased, rented or used with or without compensation.

### 600.050 Application For License And Renewal

- A. *Filing Of An Application.* Each application for an original or renewal license shall be filed with the **BUILDS Department Administrator or their designee**~~City Clerk~~ on a form to be provided by the City, signed and sworn to by the applicant. Each application shall be accompanied by a proper remittance reflecting the appropriate license fee made payable to the City.
- B. *Qualifications.* Neither the applicant nor any officer, director or shareholder of a corporate applicant shall have been convicted of a felony or of any distribution, sale or possession of any controlled substances or dangerous drugs. The applicant shall present with the application a bona fide sale contract or option duly executed, which may be subject to the applicant obtaining a liquor license, or a bona fide lease duly executed by the lessor, or an option for a lease duly executed, subject to the applicant obtaining a liquor license, covering the property for which a liquor license is requested. If the applicant is a corporation, the petition shall set forth all of the above information with respect to the managing officer or officers, identifying such officer or officers. The application shall further state the full name of the corporation, its date of incorporation, its registered agent and registered address, the names and addresses of all shareholders of the corporation, and whether said corporation operates any other business or controls or is controlled by any other corporation or business, and if so, the application shall further state the name of such controlled or controlling corporation or business, its registered agent and registered address, and the location of all businesses operated by it and the name and address of any such businesses with a liquor license, whether within or without the City; and the application shall also state if such controlling corporation or any controlled corporation is doing business under a fictitious name, and the address where said business is located. The **BUILDS Department Administrator or their designee**~~City Clerk~~ may request such additional information as ~~the Clerk may~~ **deemed** necessary or appropriate in determining whether or not an application should be granted or denied.
- C. *Review Of Application.* Upon the submission of an application to the City, the **BUILDS Department Administrator or their designee**~~City Clerk~~ shall review the application and all documents filed therewith and approve or deny the application in accordance with the following:
1. No license shall be granted for the sale of intoxicating liquor within three hundred (300) feet of any school, church or other building regularly used as a place of religious worship, unless the applicant for the license shall first obtain the consent, in writing, of the Board of Directors of the school or hospital, or the consent, in writing, of the majority of the Managing Board of the church or place of worship, except that when a school, church or place of worship

shall hereafter be established within three hundred (300) feet of any place of business licensed to sell intoxicating liquor, the license shall not be denied for lack of consent in writing as herein provided. The three hundred (300) feet distance provided for in this Section shall be measured from the center threshold of the main public entrances of such premises by the most direct walking route. No license shall be denied under this Section if a valid license to sell intoxicating beverages had been issued for the same location or address within one (1) year immediately preceding the application for a new license to be issued for the same location.

2. The ~~City Clerk~~ **BUILDS Department Administrator or their designee** shall not approve the issuance of a license if in the opinion of the ~~issu~~~~er~~ ~~Clerk~~ extraordinary or unusual circumstances exist which would result in detrimental harm to the surrounding community. In such a circumstance, the matter shall be referred to the City Council for its determination.
3. The ~~City Clerk~~ **BUILDS Department Administrator or their designee** shall approve the application and issue a license if after said application is reviewed it is found that:
  - a. The applicant is a person of good moral character, a native born or naturalized citizen of the United States of America, a registered voter and a taxpaying citizen of the City;
  - b. No license theretofore issued to such applicant to sell intoxicating liquors has been revoked within two (2) years of the date of the application;
  - c. The applicant has not been convicted since the ratification of the Twenty-First Amendment to the Constitution of the United States of the violation of any law applicable to the sale of intoxicating liquor, or that such applicant has not employed in his/her business any person whose license has been revoked or who has been convicted of violating the provisions of such law since the date aforesaid;
  - d. The applicant plans and proposes to conduct a retail liquor business in compliance with the laws of the State of Missouri, the ordinances of the City and the provisions of this Chapter;
  - e. The provisions of Subdivisions (1) or (2) of this Subsection do not apply.
- D. Upon approval of any application for a license the ~~Clerk~~ **BUILDS Department Administrator or their designee** shall grant the applicant a license to conduct business in the City for a term to expire with the thirtieth (30th) day of June next succeeding the date of such license, unless such license be revoked or suspended for cause before the expiration of such time.
- E. Applications for renewal of licenses must be filed on or before the first (1st) day of May of each calendar year. The ~~City Clerk~~ **BUILDS Department Administrator or their designee** shall review such renewal applications in accordance with the provisions of this Chapter and all other ordinances of the City which may affect any such renewal application. Upon being satisfied that the renewal application is proper and in order and upon payment of the appropriate license fee, the ~~Clerk~~ **BUILDS Department Administrator or their designee** shall renew the license.



## 600.080 Administration Of Law -- License Suspension

- A. *Suspension Or Revocation Of License — When — Manner.* The Hearing Officer may suspend or revoke the license of any person for cause shown. In such cases the City Clerk **BUILDS Department Administrator or their designee** shall schedule a hearing before the Hearing Officer not less than ten (10) days prior to the effective date of revocation or suspension, and prior to the hearing the Clerk **BUILDS Department Administrator or their designee** shall give not less than ten (10) days' written notice specifying grounds for the suspension or revocation thereof to the licensee of the grounds upon which the license is sought to be revoked or suspended and the time, date and place of the hearing. Notice may be accomplished by personal delivery, U.S. mail or by posting on the licensed premises. The hearing shall be conducted in accordance with Section 600.090 of this Chapter.
- B. *Grounds For Suspension Or Revocation.* A license may be suspended or revoked for any of the following reasons:
1. Violating any of the provisions of either this Chapter, Chapters 311 or 312, RSMo., or any ordinance of the City;
  2. Failing to obtain or keep a license from the State Supervisor of Liquor Control;
  3. Making a false affidavit in an application for a license under this Chapter;
  4. Failing to keep an orderly place or house;
  5. Selling, offering for sale, possessing or knowingly permitting the consumption on the licensed premises of any kind of intoxicating liquors, the sale, possession or consumption of which is not authorized under the license;
  6. Selling, offering for sale, possessing or knowingly permitting the consumption of any intoxicating liquor which has not been inspected and labeled according to the laws of the State of Missouri; or
  7. Selling, giving, or otherwise supplying intoxicating liquor to:
    - a. Any person under the age of twenty-one (21) years,
    - b. Any person during unauthorized hours on the licensed premises,
    - c. A habitual drunkard or to any person who is under or apparently under the influence of intoxicating liquor, or
    - d. Any person on the licensed premises during a term of suspension as ordered by the Council.
- C. *Automatic Revocation/Suspension.* A license shall be revoked automatically if the licensee's State liquor license is revoked or if the licensee is convicted in any court of any violation of Chapter 311 or Chapter 312, RSMo., or of any felony violation of Chapter 195, RSMo., in the course of business. A license shall be suspended automatically if the licensee's State liquor license is suspended, and the suspension shall be for a term not less than that imposed by the State.
- D. *Effect Of Suspension.* No person whose license shall have been suspended by order of the Hearing Officer shall sell or give away any intoxicating liquor during the time such suspension is in effect. Any licensee desiring to keep premises open for the sale of food or merchandise during the period of suspension shall display the Hearing Officer's order of suspension in a conspicuous place on the premises so that all persons visiting the premises may readily see the same.

## 600.090 Hearings Upon Suspension Or Revocation Of Licenses

- A. *Testimony — Evidence.* Hearings before the Hearing Officer shall be in the nature of a contested case. Testimony of witnesses and other evidence pertinent to the inquiry may be taken in such hearings, and all proceedings in such hearings shall be recorded. Any person residing or conducting a business within two hundred (200) feet of the establishment shall have the right to produce witnesses and testimony.
- B. *Witnesses — How Summoned.* Subpoenas may be issued by the Hearing Officer for any person whose testimony is desired at any hearing. Such subpoenas may be served and returns thereon made by any agent and in the same manner as provided by law for the service of subpoenas in civil suits in the Circuit Courts of this State. The Hearing Officer also may issue subpoenas duces tecum requiring the production of documents or other items pertaining to the subject of the inquiry.
- C. *Witnesses To Be Sworn.* Before any witness shall testify in any such hearing, he/she shall be sworn by the ~~City Clerk~~ **BUILDS Department Administrator or their designee** to tell the truth and nothing but the truth.
- D. *Decision — Suspension Or Revocation.* If the evidence supports a finding that the license should be revoked or suspended pursuant to Section 600.080 of this Chapter, the Hearing Officer shall issue a written order which shall include specific findings of fact and conclusions of law setting forth the grounds for the action taken. If the evidence fails to support a finding that the license should be revoked or suspended, then no such order shall be issued.
- E. *Appeal.* Any applicant or licensee aggrieved by a decision of the Hearing Officer may appeal such decision to the Circuit Court pursuant to the procedure set out in Code Section 430.090. The appeal shall not stay the effect of the Hearing Officer's decision.

## 605.005 Definitions

The following words, terms and phrases, when used in this Article, shall have the meanings ascribed to them in this Section, except where the context clearly indicates a different meaning:

**APPROVED** Complying with all applicable State laws and City ordinances. The word "approved" does not give any City Officer or employee discretion to fail to approve any item or method, except for failure to comply with applicable City ordinances and State laws.

**BUSINESS** Every person, sole proprietorship, corporation, partnership or other types of business enterprises, contractor, subcontractor, manufacturer, merchant or wholesaler, excluding charitable and civic groups, engaged in any business, occupation, pursuit, profession or trade or in keeping or maintaining an institution, establishment, article, utility or commodity specified in this Article, except as may be otherwise provided in this Article.

~~**CITY CLERK** The City Clerk or designated representative.~~

**CITY OFFICER** When duties and responsibilities are given to any City Officer such as the Finance Director or the Chief of Police, the duties may be performed by the named officer or any City Officer or employee under the officer's supervision, if that City Officer or employee has been assigned by his/her superior to perform the duties in question. Duties concerning drafting regulations, drafting forms or making recommendations to the City Council are not to be delegated. Duties concerning administrative appeals are not to be delegated.

**CONTRACTOR** A person who performs, or causes to be performed by employees or subcontractors, one (1) or more of the categories of building trades whether for new construction or related to maintenance or repair of existing structures or buildings.

**BUILDS DEPARTMENT ADMINISTRATOR**

**The Administrator of the BUILDS Department of the City of Republic.**

**EMPLOYEE** Any person in the regular employ of a merchant, business or contractor and whose wages, tips, commissions, fees, draw accounts, salary or any combination thereof are computed on an hourly, weekly or monthly basis.

**FEES** Unless otherwise provided, all license and permit fees and taxes levied on or required to be paid, as provided in this Code, by any merchant, manufacturer, contractor or business.

**FINANCE DIRECTOR** The Finance Director or designated representative.

**LICENSE** Unless otherwise provided, all licenses and permits required to be secured or had, as provided in this Code, by any merchant, manufacturer, business or contractor.

**LICENSE YEAR** Unless otherwise provided, the license year shall begin on January first (1st) and shall end on December thirty-first (31st) next.

**MANUFACTURER** Every person, excluding charitable and civic groups, engaged in the process of manufacturing, fabricating or refining at any place occupied for that purpose within the City, except as may be otherwise provided by ordinance.

**MERCHANT** Every person, excluding charitable and civic groups, engaged in the selling or leasing of any goods (new or used), wares (including food or beverages) or merchandise at any store, vehicle, stand or place occupied for that purpose within the City, or from catalog stores and similar operations within the City, directly to ultimate consumers for use or consumption except as may be otherwise provided by ordinance.

**PERSON** Natural person, firm, partnership, co-partnership, corporation, company, association, joint stock association and/or their lessees, duly constituted trustees or receivers, heirs, administrators or assigns.

**RETAILER** Any person who sells to a consumer or to any person for any purpose other than resale.

**SAFE** Having no defect in design, materials, workmanship, method of installation or method of normal use which creates a hazard to any person or property.

**SPECIAL EVENT** An activity that takes place ~~in~~over a short period of time usually less than one (1) week and generally occurring once per year. Examples of special events include Pumpkin Daze, the fair and the rodeo.

**SUBCONTRACTOR** A licensed contractor under contract or performing for and not on the payroll of a licensed contractor or owner.

**TEMPORARY LICENSE** An extension of time within which the prior year's license may be used to operate on a temporary basis but not to extend longer than March second (2nd) of the license year or a license issued for a brief duration as authorized in this Chapter.

**TEMPORARY SEASONAL BUSINESS LICENSE** A business license to a business that operates during a specific period of time during the year and operates ninety (90) days or less in a year.

**WHOLESALE** Any person engaged in the business of making sales of merchandise or products to any other person engaged in the business of making sales of merchandise or products at retail within the City.

#### 605.010 General Provisions

- A. *Scope.* The provisions of this Section apply to all business licenses of the City, except where an ordinance concerning a particular business contains a specific provision to the contrary, in which case the specific provision shall apply.
- B. *License Required.* It shall be unlawful for a person to operate a business within the City without first having obtained a valid business license or permit. It shall be unlawful for a person to continue to operate a business after the expiration of the license unless an application has been made for a new license and a new license has been issued.
  1. Advertising or soliciting constitutes engaging in business. It shall be unlawful for any person who is required by the provisions of this Chapter to secure a license to advertise the activity without first securing such license. The listing in an advertisement of an address which is inside the City or a telephone number which is located inside the City shall constitute prima facie evidence that the person is engaged in the business activity that is being advertised. For purposes of this Section, "advertising" means the use of any handbill, billboard, sign, newspaper, radio, loudspeaker, television, telephone listing, internet computer listing or other message or device whereby the services or products are offered to the public.
  2. It shall be unlawful for any person who is required by the provisions of this Chapter to have a license in order to engage in the licensed activity to solicit, to accept consideration or to offer the services or products to the public without first securing a license.
- C. *Application — Issuance Of License.* In the absence of a provision to the contrary, applications for business licenses shall be made to the **BUILDS Department Administrator or their designee City Clerk** on forms supplied by the **BUILDS Department Administrator or their designee City Clerk**. No license shall be issued to any merchant, manufacturer, business, occupation or trade until all of its delinquent financial obligations to the City have been paid. Financial obligations include, but are not limited to, personal property taxes, other license fees, water service fees, sewer service fees, permit fees or inspection fees. If all required information is supplied, the requested fees have been paid, and it does not appear that any applicable State law or City ordinance will be violated by the operation of the business, the license shall be issued.
- D. *Late Fee.* Businesses (except temporary and seasonal businesses) failing to submit an application for license renewal by January first (1st) will be deemed to be late and be assessed a late fee as provided for in the fee schedule found in Section 805.060.
- E. *License Non-Assignable.* No license shall be assignable, transferable or refundable.
- F. *Occupancy Permit Required.* Licenses required by this Article shall not be issued until an

occupancy permit has been issued and approved by the Community Development Department unless the business is one that in common practice would not necessarily have a business location in the City. In such a case, the business must provide the address of its business location on its application and must provide the City with notice of any change of address within a reasonable time after the change. In addition, no occupancy or building permit may be issued until such time contractors and/or subcontractors have made application for a business license. Occupancy permitting may be waived for businesses operating out of residences at the discretion of the BUILDS Department Administrator or their designee.

- G. *Issuing Agency.* The BUILDS Department Administrator or their designee~~City Clerk~~ shall issue all approved licenses and subsequent licenses.
- H. *Maintenance And Posting Of License.* All licenses granted by the City shall be carefully preserved at the address for which they were issued as shown thereon, be prominently posted and be available for examination during normal business hours by any duly authorized agent of the City.
- I. *Denial Of License.* No license or permit shall be issued to any applicant who shall have failed to pay any other obligation then due and owing to the City, including, but not limited to, sales tax, tourism tax, personal property tax, inspection fees and sewer connection fees, or be in violation of any lawfully imposed building, health, safety or zoning code and/or ordinance; nor shall any license or permit be issued to any applicant for the purpose of conducting business at any location where any neighborhood improvement district assessment is delinquent and unpaid.
- J. *Inspections.* Any business in the City may be inspected by City Officers and employees authorized to enforce provisions of ordinances relating to that business. In the absence of an emergency and in the absence of sound reasons whereby an inspection cannot be made during regular business hours, inspections shall be made during regular business hours. Immediately upon arriving at the place of business for the purpose of making an inspection, the City Officer or employee making the inspection shall identify himself/herself and shall state that the purpose of the visit is to make an inspection. No person having control of any business premises shall refuse to permit a City Officer or employee to enter for the purpose of making an inspection. If entry is refused, the City Officer or employee shall leave and seek a search warrant or other appropriate court order to gain entry.
- K. *Issuance.* Licenses shall be issued to each applicant complying with all applicable State laws and City ordinances and licenses shall be refused for any applicant failing to comply with all such applicable laws and ordinances.
- L. *Issuance Of Temporary License.* Upon application for a new business license and if the BUILDS Department Administrator or their designee~~City Clerk~~ determines that the requirements for obtaining a license have been substantially met except for minor procedural or ministerial matters, a temporary license may be issued for a period of thirty (30) days upon payment of a processing fee as provided for in the fee schedule found in Section 805.060. The temporary license may be extended for one (1) additional thirty (30) day period upon written application to the BUILDS Department Administrator or their designee~~City Clerk~~ and a determination that the applicant is making progress toward compliance with the requirements of this Code.
- M. *Issuance Of A Temporary Seasonal License.* Upon application for a temporary seasonal business license and if the BUILDS Department Administrator or their designee~~City Clerk~~ determines that the requirements for obtaining a business license have been met, a temporary seasonal business license shall be issued for a period not to exceed ninety (90)

days upon payment of a processing fee as provided for in the feeschedule found in Section 805.060. For purposes of this Chapter, a temporary seasonalbusiness license is not a renewal of a previous license but is a request for issuance of a new license **and may not be issued in lieu of renewal.**

#### 605.020 Duration Of Licenses -- Prorating Of License Fees, Etc.

- A. The term of licenses issued pursuant to this Chapter shall be for one (1) year beginning January 1 and ending December 31 of the same year. All license fees shall be paid in full and in advance.
- B. Every merchant, manufacturer, contractor or business renewing a license shall submit the required license application and fee on or before January 1. Any new merchant, manufacturer, contractor or business commencing operations or business in the last quarter of the year shall pay a prorated fee as provided for in the fee schedule found in Section 805.060.

#### 605.030 Separate License For Each Place Of Business

- A. A separate license shall be obtained for each place of business operated by a licensee under this Chapter.
- B. A license may be amended to authorize the conduct of the same business or manufacturing at a different location, provided the control of the business remains with the same person, upon filing with the **BUILDS Department Administrator or their designee** ~~City Clerk~~ an amended application, within fifteen (15) days of the change. It shall also be compulsory that all requirements of the building, health, safety or zoning codes or ordinances be met in respect to the new location and premises.

#### 605.060 Proof Of Taxes Paid Required

- A. Any person, firm or corporation who is required to pay sales tax to the City of Republic, Missouri, must show proof to the **BUILDS Department Administrator or their designee** ~~City Clerk~~ that all sales taxes due to the State of Missouri and the City of Republic, Missouri, have been paid to the date of the application prior to being issued a City business license.
- B. Any person, firm or corporation failing to provide proof of payment of such sales tax shall not be issued a City business license until such time as said State and City sales taxes and penalties and interest thereon are fully paid and the Department of Revenue for the State of Missouri certifies that same are fully paid.

#### 605.070 Violations -- Denial, Non-Renewal, Suspension Or Revocation

- A. *Delinquent Payments.* All license fees provided for in this Article shall be deemed delinquent if not paid on or before the due date.
- B. *Safety Precautions.* No contractor or trade doing business within the City limits and actively engaged in the business of electrical work, paving, plumbing, sewer work or gas fitting shall permit any unsafe conditions to be left without placement of suitable warning lights, signs or barriers and recognized suitable trench safety. Any such violation shall be deemed a public nuisance and may be abated by action for civil damages or injunction or both such remedies.
- C. *Grounds For Denial Or Non-Renewal.* The **BUILDS Department Administrator or their**

designeeCity Clerk shall not issue a business license when the City Clerk has reason to believe that the issuance of the license will result in the operation of the business in violation of this Code or that the operation of the business will cause or result in a nuisance or that a nuisance is on the land where the business is to be licensed. Upon the **BUILDS Department Administrator or their designee**City Clerk making a determination that there may be a violation of this Section, the **BUILDS Department Administrator or their designee**City Clerk shall notify the applicant in writing that the **BUILDS Department Administrator or their designee**City Clerk will not issue the license or that the **BUILDS Department Administrator or their designee**City Clerk will not renew the license, stating the reasons for the City Clerk's decision or the BUILDS Department Administrator or their designee.

- D. *Procedure For Denial Or Non-Renewal.* If the **BUILDS Department Administrator or their designee**City Clerk determines that the application for a license is not to be granted or if the **BUILDS Department Administrator or their designee**City Clerk determines not to renew the license, then a written notice to the person requesting the license or renewal thereof shall give the applicant at least five (5) days' notice to request an informal meeting with the **BUILDS Department Administrator or their designee**City Clerk. The **BUILDS Department Administrator or their designee**City Clerk shall, if an informal meeting is requested within that time, hold a meeting with the applicant, informing the applicant of the basis upon which the decision was made and shall attempt to informally resolve the matter. The informal meeting shall be held within ~~five~~ **ten (10)** working days of receipt of the written request for an informal meeting. After such informal meeting, the **BUILDS Department Administrator or their designee**City Clerk may reverse the City Clerk's decision **of the BUILDS Department Administrator or their designee** or may reaffirm the prior decision in writing. The City Clerk's written decision **of the BUILDS Department Administrator or their designee** shall be issued within five (5) days of the informal meeting. Thereafter, the applicant may request a public hearing by filing a written request with the **BUILDS Department Administrator or their designee**City Clerk within ten (10) days of the date of the City Clerk's written decision **of the BUILDS Department Administrator or their designee**. At the public hearing, a hearing officer appointed by the City Administrator shall hear evidence, determine the facts upon the evidence presented at the hearing and render a decision. The public hearing shall be held within twenty (20) days of the receipt of the written request by the **BUILDS Department Administrator or their designee**City Clerk. The decision of the hearing officer shall be in writing and shall be issued within ten (10) days of the hearing. The hearing may be continued by the hearing officer for good cause shown by any party to the proceeding.
- E. *Revocation Or Suspension Of License Authorized.* The license of a merchant, manufacturer, contractor or business may be revoked by a hearing officer after public hearing and notice for any one (1) or more of the following reasons:
1. Failure to comply with the provisions of this Article or any other ordinance pertaining to the business codes, building codes, fire codes, health codes or zoning codes or ordinances of the City.
  2. Failure to operate the business as required by law.
  3. Creation of a public nuisance.
  4. Providing false information to obtain a license.
  5. Failure to pay any obligation due and owing to the City.
- F. *Notice Of Suspension Or Revocation Hearing.* Upon the **BUILDS Department Administrator or their designee**City Clerk determining that a possible violation of this Article has occurred, the **BUILDS Department Administrator or their designee**City Clerk shall issue a notice that

a hearing relative to the possible suspension or revocation of the business license is to be held pursuant to this Section. The licensee shall have at least five (5) days' written notice of the time and place of such hearing. The written notice shall be directed by certified or registered U.S. mail to the business address of the licensee on the licensee's application on file in the office of the **BUILDS Department Administrator or their designee**~~City Clerk~~ and shall specify the grounds upon which the license is sought to be suspended or revoked.

At the public hearing, a hearing officer appointed by the City Administrator shall hear evidence, determine the facts based upon the evidence presented at the hearing and render a decision. The decision of the hearing officer shall be in writing and shall be issued within ten (10) days of the hearing. The hearing may be continued by the hearing officer for good cause shown by any party to the proceeding.

- G. *Hearing On Suspension Or Revocation — Appeals.* The licensee may present such evidence on licensee's behalf as the Hearing Officer deems relevant. The Hearing Officer's decision may be appealed pursuant to the procedure set out in Code Section 430.090. The appeal shall not stay the effect of the Hearing Officer's decision.
- H. *Conduct Of Hearings.* The hearing officer shall have all the powers set forth in this Article and Chapter 430 of this Code and shall conduct the hearing in accordance with the procedures set forth in this Article and Chapter 430. The hearing officer shall determine whether or not there is a basis for not issuing the license, not renewing the license, suspending the license or revoking the license. The decision of the hearing officer and the right to appeal his decision shall be in accordance with this Article and Chapter 430 of this Code. All notice for purposes of this Section shall be deemed to occur two (2) days after the date the notice is placed in the United States mail, postage prepaid.
- I. *Suspension Disposition.* If the hearing officer determines that the violation has been corrected or that the licensee is actively and continuously working to correct the violation, then the hearing officer may issue a suspension order not to exceed sixty (60) days. Upon expiration of the period of suspension, the licensee shall submit a written request to the **BUILDS Department Administrator or their designee**~~City Clerk~~ for reinstatement of the license. If the **BUILDS Department Administrator or their designee**~~City Clerk~~ determines that the licensee is in compliance with the requirements of this Article, the **BUILDS Department Administrator or their designee**~~City Clerk~~ shall issue a written notice of reinstatement. If the **BUILDS Department Administrator or their designee**~~City Clerk~~ determines that the licensee is not in compliance with this Article, the proceedings for revocation of a license shall be instituted.
- J. *Revocation Disposition.* If the hearing officer determines that there is a violation of this Article that has not been corrected or that the violation is incapable of being corrected or that the licensee is not actively and continuously working to correct the violation, the hearing officer shall revoke the business license. Upon revocation of a license, a business shall not be eligible to apply for a business license in the City for one (1) year from the date of revocation. After one (1) year, the licensee may apply for a license subject to meeting all requirements set forth in this Article.
- K. *Discontinuance Of Or Withholding Of City Services.* The City, its boards, commissions or agents shall withhold or discontinue all City improvements or services of whatsoever nature, including the furnishing of sewer, water, electricity and gas, and further, no permits shall be issued by the Community Development Department or Public Works Department to any entity or persons operating a business within the City limits without a valid business license issued pursuant to this Article. Disconnection from the City water utilities may be carried out if such violation is not corrected within ten (10) days after delivery of a notice of such



violation.

#### 605.110 License -- Fees

- A. The license required by Section 605.100 shall be issued by the **BUILDS Department Administrator or their designee**~~City Clerk~~ upon payment of a fee as provided for in the fee schedule found in Section 805.060.
1. A vehicle with a capacity of one-half (1/2) ton or less.
  2. A vehicle with a capacity of one-half (1/2) ton not exceeding one and one-half (1 1/2) ton.
  3. A vehicle with a capacity of over one and one-half (1 1/2) ton.

#### 605.130 Collection And Accounting For Taxes Collected Under Article

The license taxes provided for in Section 605.110 shall be collected by the Director of Finance and accounted for as other license taxes. The license required by Section 605.100 shall not be issued until the amount prescribed therefor shall have been paid to the Director of Finance, and no license shall be assigned or transferred. All licenses shall be signed ~~by the Mayor and attested by~~ **by the BUILDS Department Administrator or their designee**~~City Clerk and countersigned by the Director of Finance.~~

#### 605.140 Exchange Telephone Service -- License Tax

- A. Every person, firm, company or corporation now or hereafter engaged in the business of furnishing exchange telephone service in the City of Republic, Missouri, shall pay the said City as an annual license tax, three percent (3%) of the gross receipts derived from the furnishing of such service within said City, as hereinafter set forth.
- B. All such persons, firms, companies or corporations mentioned in Subsection (A) hereof shall file with the **BUILDS Department Administrator or their designee**~~City Clerk~~ of the said City on or before the fifteenth (15th) day of July, 1969, a sworn statement of the gross receipts derived by such person, firm, company or corporation from the furnishing of such service during the period from January 1, 1969 to June 30, 1969 and on or before the fifteenth (15th) day of July and January of each calendar year thereafter a similar statement of the gross receipts derived by such person, firm, company or corporation from the furnishing of such service during the six (6) month period immediately preceding. At the time of filing any such statement, the person, firm, company or corporation involved shall pay to the City Collector of the City three percent (3%) of such gross receipts.
- C. The first payment of tax provided for herein shall be due and payable on July 15, 1969 and shall be for the period from January 1, 1969 to June 30, 1969.
- D. The payments required by the provisions of this Section shall be in lieu of all other excises, changes, exactions, rentals, impositions or other license or occupation taxes heretofore imposed upon any person, firm, company or corporation engaged in the business described in Subsection (A) hereof, but nothing herein contained shall be construed to exempt such person, firm, company or corporation from any general or special ad valorem tax imposed upon the public generally by said City.
- E. By letter dated April 12, 2006, the Director of Revenue set forth information as to gross receipts and taxes paid by telecommunications companies. The figures appear to show a substantial under payment of taxes to the City of Republic and are at best in need of further analysis to determine if other inaccuracies in the figures may exist that would

substantially alter the calculation of the revenue neutral rate. That based upon the most reliable information now before the Board, the Board determines that the revenue neutral rate for the City of Republic to be three percent (3%) and the percentage set forth in Subsections (A — B) of this Section is adjusted to reflect the revenue neutral rate and is to be effective July 1, 2006.

- F. It is the intent of the City of Republic to fully comply with the requirements of law; however, certain Cities in the State of Missouri have filed suit challenging the validity of Section 92.086, RSMo., and should a court of law determine in that case or any other case instituted to establish a different revenue neutral rate for the City of Republic that a lesser rate should apply, then the City's rate shall be adjusted to meet the judgment of the court upon exhaustion of all appeals.

#### 610.060 Identification Card -- Termination

- A. Any registration may be revoked or suspended upon a finding by the Hearing Officer that the registrant has failed to maintain compliance with the provisions of this Chapter or the conditions of the ~~City Clerk's~~ acceptance of the application by the **BUILDS Department Administrator or their designee**.
- B. The hearing procedures set forth in Code Section 605.070 shall apply to this Chapter.

#### 610.070 Licenses Required

No professional solicitor shall participate in public solicitation until he/she has obtained the proper licensing from the **BUILDS Department Administrator or their designee**~~City Clerk~~ and has paid the applicable merchant license fee.

#### 610.090 Reports By Registrants -- Records Open To Inspection

All persons registered with the **BUILDS Department Administrator or their designee**~~City Clerk~~ must maintain, for his/her inspection or that of his/her duly authorized agent, complete records of all transactions in which the registrant engages and for which the public solicitation was made.

#### 610.100 Solicitations From Occupants Of Motor Vehicles Prohibited

Without prior approval from the **BUILDS Department Administrator or their designee**~~City Clerk~~, it shall be unlawful for any person to engage in any public solicitation from the occupants of any motor vehicle while said motor vehicle shall be upon the public streets or ways of the City unless the vehicle shall be lawfully parked at the time of said solicitation.

#### 615.030 License Fee

- A. Any person obtaining a license to act as a massage business shall pay to the **BUILDS Department Administrator or their designee**~~City Clerk~~ a license fee as provided for in the fee schedule found in Section 805.060. The term of licenses issued shall be for one (1) year beginning January 1 and ending December 31 of the same year. All license fees shall be paid in full and in advance. Any new massage business commencing business in the last quarter of the year shall pay a prorated fee as provided for in the fee schedule found in Section 805.060.
- B. Every massage business renewing a license shall submit the required license application and fee on or before January 1.

## 630.010 Definitions

For the purposes of this Chapter the following terms, phrases, and words shall have the following meanings unless otherwise indicated by context:

CHIEF OF POLICE The Chief of Police of the City of Republic Police Department. ~~CITY CLERK The person appointed by Council of the City of Republic to perform the City Clerk duties.~~

**BUILDS DEPARTMENT ADMINISTRATOR**

**The Administrator of the BUILDS Department of the City of Republic.**

DIRECTOR OF FINANCE The Director of Finance of the City of Republic.

MONTH Period of time from one date in a calendar month to the corresponding date in the following calendar month, but if there is no such corresponding date, then the last date of such following month, and when computations are made for a fraction of a month, a day shall be one-thirtieth (1/30th) of a month.

NET ASSETS The book value of the current assets of a person or pawnbroker less its applicable liabilities as stated herein. Current assets include the investment made in cash, bank deposits, merchandise inventory, and loans due from customers, excluding the pawn service charge. Current assets do not include the investments made in fixed assets of real estate, furniture, fixtures, or equipment; investments made in stocks, bonds, or other securities; or investments made in prepaid expenses or other general intangibles. Applicable liabilities include trade or other accounts payable; accrued sales, income, or other taxes; accrued expenses; and notes or other payables that are unsecured or secured in whole or part by current assets. Applicable liabilities do not include liabilities secured by assets other than current assets. Net assets must be represented by a capital investment unencumbered by any liens or other encumbrances to be subject to the claims of general creditors.

PAWNBROKER Any person engaged in the business of lending money on the security of pledged goods or engaged in the business of purchasing tangible personal property on condition that it may be redeemed or repurchased by the seller for a fixed price within a fixed period of time.

PAWNSHOP The location at which, or premises in which, a pawnbroker regularly conducts business.

PERSON An individual, partnership, corporation, limited liability company, joint venture, trust, association, or any other legal entity however organized.

PERSON OF GOOD MORAL CHARACTER A person who has not been convicted of any State, Federal, or municipal offense involving drugs or narcotics, robbery, burglary, theft, stealing, receiving stolen property, embezzlement, extortion, forgery, gambling, bribery, perjury, any weapons offense, or any crime of violence.

PLEGGED GOODS Tangible personal property other than choses in action, securities, or printed evidence of indebtedness, which property is deposited with, or otherwise actually delivered into the possession of, a pawnbroker in the course of his/her business in connection with a pawn transaction.

SECURED PERSONAL CREDIT LOAN Every loan of money made in this City, the payment of which is secured by a security interest in tangible personal property which is physically delivered into the hands of the lender at the time of the making of the loan and which is to be retained by the lender while the loan is a subsisting obligation.

#### 630.020 Licenses

- A. *Licenses Required.* No person shall operate a pawnshop in the City of Republic unless such person obtains a pawnshop license issued by the City in accordance with the general licensing provisions of the Municipal Code and the specific provisions of this Chapter. A license is required for each place where pawnbroking business is transacted, and no one shall act as an agent, employee, or solicitor for any pawnbroker while such pawnbroker is engaged in such business at a place other than that specified in the license. It shall be unlawful for any person to conduct or transact a pawnbroker business in the City unless he/she shall keep posted in a conspicuous place in the place of business, license certificate therefor, and a copy of all ordinances relating to pawnbrokers.
- B. *Licensing Year.* All licenses issued under this Chapter are for a period of one (1) year, or portion of one (1) year, and expire on Midnight of March fifteenth (15th). The license fee for any license which is issued for a portion of a year shall be prorated by the **BUILDS Department Administrator or their designee**~~City Clerk~~.
- C. *Application For New Pawnshop License.* An application for a new pawnshop license shall be under oath and on forms prescribed and provided by the **BUILDS Department Administrator or their designee**~~City Clerk~~ and shall contain other relevant information sufficient to inform the **BUILDS Department Administrator or their designee**~~City Clerk~~ regarding the qualifications of the applicant for a license as required by the **BUILDS Department Administrator or their designee**~~City Clerk~~. At a minimum, the application shall include:
1. The full name and address of the applicant, and each prospective pawnshop employee, if known, for the past two (2) years;
  2. The address where the business is to be conducted;
  3. A statement as to whether the applicant, and each prospective pawnshop employee, if known, have ever been convicted of a felony;
  4. The name, address and phone number of at least two (2) persons of good moral character who may be used as character references for the applicant, and each prospective pawnshop employee, if known; and
  5. If the applicant is a partnership, the application shall include the required information for each partner, and whether such partner is a general partner or a limited partner. If the applicant is a corporation or limited liability company, the application shall include the required information for each officer, shareholder and director.
  6. The application shall be accompanied by:
    - a. An investigation fee is required, as provided for in the fee schedule found in Section 805.060, if the applicant is unlicensed at the time of applying for the pawnshop license, an additional fee is required as provided for in the fee schedule found in Section 805.060, if the applicant is unlicensed at the time of applying for the pawnshop license, or two hundred fifty dollars (\$250.00) if the application involves a second (2nd) or additional license to an applicant previously licensed for a separate location, or involves substantially identical principals and owners of a licensed pawnshop at a separate location;

- b. Proof of general liability insurance in the amount of five hundred thousand dollars (\$500,000.00);
  - c. An annual fee as provided for in the fee schedule found in Section 805.060; and
  - d. If the applicant is a corporation, a "certificate of good standing" issued by the Missouri Secretary of State.
- D. *Non-Use And Transfer Of License.*
- 1. If a pawnbroker shall not conduct business for any continuous period of ninety (90) days at any time after the issuance of a license, the license shall be null and void.
  - 2. Licenses are personal to the licensee and shall not be transferred to any other person. Any attempt to transfer such license to any other person shall render said license null and void. It shall be unlawful for any person to do business, or to attempt to do business under a license transferred to him.
- E. *Investigation By BUILDS Department City Clerk. The BUILDS Department Administrator or their designee City Clerk shall investigate the facts contained in an application for a new pawnshop license, and shall request the assistance of the Chief of Police and any other person who has knowledge of the facts contained in the application or who is authorized to investigate these facts.*
- F. *Standards For Issuance.* No license shall be issued to any person who:
- 1. Is not of good moral character, or to any pawnshop employing persons who are not of good moral character;
  - 2. Makes a false statement of material facts in the application for a license or a renewal license;
  - 3. Fails to show that the pawnshop will be operated lawfully and fairly within the purposes of the Chapter;
  - 4. Has a felony or misdemeanor conviction which either directly relates to the duties and responsibilities of the occupation of pawnbroker or which otherwise makes the applicant presently unfit for a license;
  - 5. Does not have net assets of at least fifty thousand dollars (\$50,000.00) readily available for use in conducting business as a pawnshop for each licensed pawnshop; or
  - 6. Does not file with the BUILDS Department Administrator or their designee City Clerk a bond satisfactory to the BUILDS Department City Clerk in an amount of five thousand dollars (\$5,000.00) with a surety company qualified to do business in this City. The aggregate liability of such surety shall not exceed the amount stated in the bond. The bond shall run to the City for the use of the City and of any person(s) who may have a cause of action against the obligor of such bond under the provisions of this Chapter. Such bond shall be conditioned that the obligor will comply with the provisions of this Chapter and by all rules and regulations adopted by the BUILDS Department Administrator or their designee City Clerk and will pay to the City and to any such person(s) any and all amounts of money that may become due or owing to the City or to such person(s) from such obligor under and by virtue of the provisions of this Chapter or any rules adopted by the BUILDS Department Administrator or their designee City Clerk pursuant to this Chapter during the time such bond is in effect.

If the BUILDS Department Administrator or their designee City Clerk is unable to verify that the applicant meets the net assets requirement for a licensed pawnshop as required

by Subparagraph (5) of this Subsection, the **BUILDS Department Administrator or their designee**~~City Clerk~~ may require a finding, including the presentation of a current balance sheet, by an independent certified public accountant, that the accountant has reviewed the books and records of the applicant, and that the applicant meets the net assets requirement of this Chapter.

- G. *Exemption From Requirement For New Pawnshop License.* No person who is lawfully operating a pawnshop on the date of the enactment of this Chapter shall be required to obtain a license under this Section in order to continue operating such pawnshop, so long as such person does not violate any other provisions of Sections 367.011 to 367.060, RSMo., or this Chapter. Such persons may continue to operate those pawnshops then in existence, but thereafter must receive annual renewal licenses even though the operation of such pawnshop might cause the number of pawnbrokers in the City to exceed the number determined by operation of Subsection (H) hereof. Such persons shall be required to pay the five hundred dollar (\$500.00) annual fee prescribed in Subsection (I), but such payment shall be in lieu of any occupational license fee.
- H. *Limitation On Number Of Pawnbrokers In The City.* Subject to the provisions of Subsection (G) hereof, no license for engaging in the business of pawnbroker shall be issued when the issuance thereof would increase the number of such licenses outstanding and in force at that time to more than one (1) per each twelve thousand (12,000) inhabitants residing in the City.
- I. *Subsequent License Applications.* Subsequent to the first year for which a license is issued to a pawnbroker, each pawnbroker shall make a renewal application to the **BUILDS Department Administrator or their designee**~~City Clerk~~. The application shall be filed by March first of the current licensing year, and shall be on the forms, and shall contain such information, as the **BUILDS Department Administrator or their designee**~~City Clerk~~ may require. The forms shall contain such information as will assist the **BUILDS Department Administrator or their designee**~~City Clerk~~ in determining whether conditions have changed and whether a renewal license should be issued for the subsequent licensing year. The **BUILDS Department Administrator or their designee**~~City Clerk~~ may request the assistance of the Chief of Police or any other City employee or person having knowledge of the truth or falsity of the matters contained in the application, or who is able to investigate those matters. The annual fee for the issuance of a renewal license applies as provided for in the fee schedule found in Section 805.060.
- J. *Denial, Suspension Or Revocation Of License.*
1. If the **BUILDS Department Administrator or their designee**~~City Clerk~~ believes that any condition prevents issuance of a license or such condition has changed in the case of a renewal of a license such that the licensee would not be eligible to receive a pawnbroker's license, or that the licensee is in violation of this Chapter or any State or municipal law, the **BUILDS Department Administrator or their designee**~~City Clerk~~ shall notify the licensee in writing of the intended action and the reasons therefor and the hearing procedures set forth in Code Section 605.070 shall apply.
  2. If the **BUILDS Department Administrator or their designee**~~City Clerk~~ believes that the licensee is capable of remedying the adverse change in conditions, and if the licensee has not previously been in violation of this Chapter or State or municipal law, the **BUILDS Department Administrator or their designee**~~City Clerk~~ shall notify the licensee in writing of the intended action and the reasons therefor and the hearing procedures set forth in Code Section 605.070 shall apply. If the **BUILDS**

Department Administrator or their designee~~City Clerk~~ believes that the changed condition(s) are such that, if true, the licensee would not be able to remedy the situation in a reasonable time, or if the licensee has previously been in violation of this Chapter or State or municipal law, then the BUILDS Department Administrator or their designee~~City Clerk~~ shall notify the licensee in writing of the intended action and the reasons therefor and the hearing procedures set forth in Code Section 605.070 shall apply.

3. If the BUILDS Department~~City Clerk~~ believes that the safety, morals, or peace of residents of the City is immediately affected by the change in conditions, the BUILDS Department Administrator or their designee~~City Clerk~~ may suspend or revoke the license prior to the hearing called for below, but he/she shall afford the licensee an informal meeting to determine if the emergency suspension should continue in place and the informal meeting will be within five (5) business days of the suspension or revocation. If the BUILDS Department Administrator or their designee~~City Clerk~~ believes that the changed condition is not of such imminent hazard to the safety, morals, or peace of the residents of the City, he/she shall notify the licensee in writing of the intended action and the reasons therefor and the hearing procedures set forth in Code Section 605.070 shall apply. This procedure shall apply to a hearing as a result of an emergency suspension described above.

K. *Issuance Of Pawnshop Licenses Prohibited, When.*

1. No license shall be issued for the operation of a pawnshop as defined within this Chapter wherein said pawnshop will be located within one thousand (1,000) feet of any church or other building regularly used as a place of religious worship, school, or residentially zoned property. The one-thousand-foot distance provided for in this Section shall be measured from the center threshold of the main entrances of such premises by the most direct walking route.
2. No license shall be issued for the operation of a pawnshop as defined in this Chapter wherein said pawnshop will be located within one thousand (1,000) feet of property on which there is located another pawnshop. The one-thousand-foot distance provided for in this Section shall be measured from the center threshold of the main entrances of such premises by the most direct walking route.
3. No license shall be issued for the operation of a pawnshop as defined in this Chapter wherein said pawnshop will be located within one thousand (1,000) feet of any residence, unless the licensee shall provide to the BUILDS Department Administrator or their designee~~City Clerk~~ written authorization for such operation from the owner of record of such property and each adult resident thereof. The one-thousand-foot distance provided for in this Section shall be measured from the center threshold of the main entrances of such premises by the most direct walking route.

631.010 Purchase Documentation

- A. Any business offering payment for the purchase of gold, silver or other precious metal, including, but not limited to, aluminum, copper, bronze or precious or semi-precious stones and/or jewelry shall, prior to accepting any such items:
  1. Every person required to make and maintain records shall make a daily report to the Chief of Police, giving a complete description of all articles purchased or taken in barter or exchange by him or pledged with him, including the date of the transaction, any number, letter, marking or engraving that may be on such

property for the purposes of identification, including any owner-applied markings, and the first and last name, residential address, driver's license number, military identification number, identification certificate number, or other official number capable of identifying the seller or pledger, race, sex, color of eyes and hair, and height and weight of the person from whom a purchase was made. For all property purchased or taken in barter or exchange, an acknowledgment that the seller provided the dealer at the time of the sale or barter or exchange with a signed document that the seller had the right to sell the property.

- a. Any person selling any of the items listed in this Section must provide the person taking such goods a valid government-issued identification to complete required forms.
  - b. No person or business, either wholesale or retail, shall receive any personal property from any minor without written consent of such minor's parents or guardian.
2. Every person regularly engaged in or conducting business for the purchase, sale, barter, exchange, recycling, reselling of antiques, coins, any metal including, but not limited to, aluminum, copper, gold, silver, brass, bronze and platinum, gems and semi-precious stones, watches, both wholesale and retail, shall keep a substantial and well-bound book or other form of permanent record in which he/she shall legibly and permanently enter a description of all personal property, including precious gems or metals, pledged or purchased by him/her, except those items purchased from wholesale dealers, including any number, letter, marking or engraving that may be on such property for purposes of identification, including any owner-applied markings. For purposes of this Chapter, the term "*offering payment*" means the purchase, sale, barter or exchange of any item mentioned in this Subsection, including the advertising thereof, and including such business conducted by an established dealer in a permanent location, and including any temporary, transient or itinerant business, whether or not such dealer is engaged in other business activities at such locations.
- a. If such property contains in whole or in part a precious gem or metal and such property is difficult to describe, the property shall be photographed and the photograph shall be attached to the record book or kept with the other permanent record describing the property. The amount of the loan or purchase price and, if a loan, the time when the loan shall be due, and the interest charged therefore shall also be recorded.
  - b. Such records shall not be defaced or erased and shall be open to any Peace Officer as defined in Section 590.010, RSMo., together with the articles purchased or pledged, provided that the articles shall be still in the possession of the dealer or merchant. For purposes of this Chapter, a secondhand dealer shall include, but not be limited to, those persons who purchase items for resale at flea markets and persons other than wholesale dealers in such items.
  - c. Every person or business required to keep permanent records under this Section shall keep those records for a period of at least two (2) years from the date of the last transaction recorded therein.
  - d. Every person or business shall make their reports of such property (pledged, taken in barter or exchange, or purchased) electronically as set out in Section 367.031, RSMo., and shall report the information prescribed by that Statute and Subsection 90-3(a) to the electronic



database as authorized by the Statute. If more than one (1) such electronic database is available for such reporting, each dealer or person so licensed shall make their reports to the database directed for such reporting by the Chief of Police. The database designation information shall be on file with and available at the Police Department headquarter and the **BUILDS Department Administrator or their designee**~~City Clerk~~.

- B. Each dealer or person licensed by the City and engaged in such business as described in this Subsection, in lieu of making the daily report to the Chief of Police as described in the preceding Subsection, shall make their daily reports of such property (pledged, taken in barter or exchange, or purchased) electronically as set out in Section 367.031, RSMo., and shall report the information prescribed by that Statute and in the preceding Subsection to the electronic database as authorized by the Statute. If more than one (1) such electronic database is available for such reporting, each dealer or person so licensed shall make their reports to the database directed for such reporting by the Chief of Police. This database designation information shall be on file with and available at the Police Department headquarters and the **BUILDS Department Administrator or their designee**~~City Clerk~~.
1. Every person required to make and maintain records pursuant to this Section, in addition to the report required in Subsection (B), shall make a report of any purchase, sale, barter or exchange of scrap metal, including aluminum, copper, platinum and all other metals regardless of kind or type, with a value of fifty dollars (\$50.00) or more within twenty-four (24) hours of the purchase, sale, barter or exchange to the Chief of Police in an electronic database designated by such Chief. The electronic database form or report shall be completed in full without missing data or information.
- C. No gold, silver, diamonds or other precious or semi-precious gems or precious metals received or purchased by any person subject to Subsection (A), including, but not limited to, all persons license by the City and engaged in such business as described in Subsection (A), shall be removed from a designated location within the City within ten (10) days after receipt thereof, except when redeemed by the owner, nor shall any such precious gems or precious metals be melted or recut within ten (10) days from the receipt thereof, except when redeemed by the owner. Further, no person subject to Section 631.010, including, but not limited to, all persons licensed and engaged in such business as described in Subsection (A), shall sell, transfer ownership or possession of, or otherwise remove from said designated location any goods of any kind or type, including, but not limited to, all items described in Subsection (A), received in purchase, sale, barter, exchange for seventy-two (72) hours from the time of the receipt of such goods, except for redemption of such goods by the owner.
- D. The requirements of this Section are in addition to any other requirements on businesses found elsewhere in the Republic Municipal Code.
- E. Violations of this Section shall be punishable by the general punishment provisions set forth in Section 100.220 of the Republic Municipal Code.

#### 610.040 Identification Card -- Application

- A. Any person required to register under Section 610.020 shall make application to the ~~City Clerk~~ **BUILDS Department Administrator or their designee** upon an approved form for registration. No application will be accepted until satisfactory evidence is presented to the ~~City Clerk~~ **BUILDS Department Administrator or their designee** that:
1. ~~The applicant is of good moral character;~~

- 2- Shall not have been convicted of a felony in the last five (5) years;
- 3- Shall not have had his/her registration revoked within the past three (3) years;and
- 4- Shall have paid a non-refundable annual application fee as provided for in the fee schedule found in Section 805.060 for a calendar year. In addition, a person may obtain a quarterly permit for ninety (90) days as provided for in the fee schedule found in Section 805.060.
- 5- The applicant shall deliver the application in person to City Hall.

#### 610.080 Background Check

For purposes of ascertaining if criminal convictions have occurred, ~~fingerprinting of applicants or licensees for the purpose of receiving~~ criminal history record information shall be required with the applicants or licensees bearing **both the responsibility and** the cost of obtaining the criminal record history per the fees established by the State of Missouri. A criminal history shall be good for a period of January first (1st) through December thirty-first (31st) of the year of the application.



## AGENDA ITEM ANALYSIS

Project/Issue Name: 21-R-49 A Resolution of the City Council of the City of Republic, Missouri, Approving a Preliminary Plat for Emerald Valley Phase 2, a Residential Subdivision Consisting of Approximately 48 Acres Located in the 1300 Block of North Main Street.

Submitted By: Chris Tabor, Principal Planner for BUILDS Department

Date: October 19, 2021

### Issue Statement

Bester Properties LLC has requested review and approval of a Preliminary Plat of Emerald Valley Phase 2, a subdivision of approximately forty-eight (48) acres, consisting of one hundred and forty-five (145) residential lots zoned Single Family Medium Density Residential (R1-M), streets, and infrastructure.

**Conformity with Preliminary Plat Review Criteria:** Preliminary Plats are reviewed for their conformance with the following review criteria to ensure the development, in the proposed location:

- (1) Will not endanger the public health or safety;
- (2) Will not injure the value of adjoining property or abutting property;
- (3) Will be in conformity with the Comprehensive Plan, Transportation Plan, Zoning Code, Water System Master Plan, Wastewater System Facility Plan, or other plans officially adopted by the City Council; and
- (4) Will be in harmony with the area in which it is located

Preliminary Plats are reviewed by the City Planner and the City Engineer in conformance with the requirements of Chapter 410 of Republic's Municipal Code, the Comprehensive Plan, and all applicable City adopted codes and regulations.

### Discussion and/or Analysis

The property subject to this Preliminary Plat Application is comprised of approximately forty-eight (48) acres of land located at the 1300 Block of North Main Street. The property is zoned Single Family Medium Density Residential (R1-M).

The following paragraphs contain brief analyses of the application's conformity with the Preliminary Plat Review Criteria identified above.

### **Consistency with the Comprehensive Plan**

The referenced Preliminary Plat contains (145) Single Family Medium Density Residential (R1-M) lots with a minimum required lot size of 9,000 square feet and consists of streets, open space, utility easements, and detention areas. The Preliminary Plat of Emerald Valley Phase 2 has a density of 3 lots/acre.

### **Transportation Plan**

The Preliminary Plat proposes two new Street connections: Topaz Boulevard and Citrine Street will both connect to Main Street. There are two future connection points created by this subdivision to serve future development: Topaz Boulevard, which terminates to the east, and Sapphire Avenue, which terminates to the north. These connections allow those adjacent parcels access to Emerald Valley as development progresses. New public streets will be dedicated to the City during the Final Platting Process; deficient Right-of-Way (ROW) along North Main Street will be dedicated to the City during the Final Platting Process.

A Traffic Impact Study (TIS) was required of the Applicant. The Study required determined that the future intersection of Main Street and Topaz Boulevard will require a designated southbound left turn lane.

### **Water and Wastewater Master Plan**

The referenced parcel is not currently connected to municipal utilities, development of the property will require connection to the City's water and sanitary sewer systems. Development will require an extension of the existing water main along the east side of Main Street (transitioning from a 10-inch to an 8-inch) from Emerald Valley Phase 1 to the northern edge of the new subdivision. The looping of the water system is expected to create a connection with the 6-inch main on North Hampton Avenue.

Wastewater will gravity-feed north from the east property line through an 8-inch main to the Evergreen Lift Station and then pumped to the Wastewater Treatment Plant.

Both the water and sewer system currently have the capacity to serve the potential development.

### **Zoning Code**

The Preliminary Plat of Emerald Valley Phase 2 has been platted for the construction of one hundred forty-five single-family lots, associated infrastructure, including public streets and sidewalks, public water and sanitary sewer mains, and stormwater detention.

**Floodplain:** The subject parcel **does** contain a Special Flood Hazard Area (SFHA/Floodplain); development of the subject parcel will require compliance with the City's Floodplain Ordinance.

**Sinkholes:** The subject parcel contains one (1) identified sinkhole, located between lots 194 and 195 along the south side of Sapphire Avenue. A Sinkhole Analysis was completed by the Applicant and reviewed by the City; development of the property



requires compliance with Section 410.700 Sinkholes and Karst Features of the Republic Municipal Code, requiring a thirty (30) foot setback from the sinkhole rim for all development. The Preliminary Plat for Emerald Valley Phase 2 meets the requirements of the referenced Ordinance.

**Stormwater:** The Preliminary Plat contains two Stormwater Detention Areas between designed to control the release of stormwater attributable from the development; the first, 2.93 acres on the south edge of the subdivision, the second, 0.97 acres in the northwest corner. The Plat contains a conceptual layout of the Detention Area; the area will be designed to mitigate existing conditions to reduce the amount of post-development flows to less than pre-development flows. The Stormwater Detention Area's outflow will flow onto adjacent property to the south of the property; a Stormwater Report will be reviewed by the TRT during Infrastructure Design review. The Stormwater Detention Area and all open space/common area will be maintained by a Homeowner's Association.

**Infrastructure Design:** The design of the streets, sidewalks, water and sanitary sewer systems, and stormwater detention will be reviewed and permitted during the Infrastructure Permitting Process.

#### **Recommended Action**

Staff considers the **proposed Preliminary Plat in general conformity with the requirements for Preliminary Plats and is recommending approval of the application.**

RESOLUTION NO. 21-R-49

**A RESOLUTION OF THE CITY COUNCIL OF THE CITY OF REPUBLIC, MISSOURI, APPROVING A PRELIMINARY PLAT FOR EMERALD VALLEY PHASE 2, A RESIDENTIAL SUBDIVISION CONSISTING OF APPROXIMATELY 48 ACRES LOCATED IN THE 1300 BLOCK OF NORTH MAIN STREET**

*WHEREAS*, the City of Republic, Missouri, (herein called the “City” or “Republic”) is a municipal corporation and Charter City located in Greene County, Missouri, being duly created, organized, and existing under the laws of the State of Missouri; and

*WHEREAS*, the Planning and Zoning Commission and the City Council have adopted Subdivision Regulations and plans governing the subdivision of land within the City; and

*WHEREAS*, the Preliminary Plat for the Emerald Valley Phase 2 residential subdivision consisting of approximately 48 acres and located in the 1300 Block of North Main Street has been reviewed by the BUILDS department, City Planner and City Engineer, (“Staff”) for conformance with the requirements of applicable City codes and regulations, including Chapter 410 of the City’s Municipal Code, all plans officially adopted by City Council, public safety, and area impact; and

*WHEREAS*, Staff considers the proposed Preliminary Plat to be in general conformity with the requirements for Preliminary Plats and is recommending approval of the application for same; and

*WHEREAS*, the Planning and Zoning Commission considered the proposed Preliminary Plat on October 12, 2021, after which the Commission rendered written findings of fact, and thereafter, submitted the same together with its recommendations, to the Council; and

*WHEREAS*, the Planning and Zoning Commission, by a vote of 6 Ayes to 0 Nays, recommended approval of such proposed Preliminary Plat.

***NOW, THEREFORE, BE IT RESOLVED BY THE CITY COUNCIL OF THE CITY OF REPUBLIC, MISSOURI, AS FOLLOWS:***

- Section 1. The Preliminary Plat for the Emerald Valley Phase 2 residential subdivision consisting of approximately 48 acres and located in the 1300 Block of North Main Street, attached as Exhibit A, shall serve as the guide to the development of the subdivision.
- Section 2. The Preliminary Plat generally complies with the requirements for Preliminary Plats.
- Section 3. The whereas clauses are hereby specifically incorporated herein by reference.
- Section 4. This Resolution will become effective on and after the date of passage and approval as provided by law.

***PASSED AND APPROVED*** at a regular meeting of the City Council of the City of Republic, Missouri, this 19th day of October 2021.

RESOLUTION NO. 21-R-49

\_\_\_\_\_  
Matt Russell, Mayor

Attest:

\_\_\_\_\_  
Laura Burbridge, City Clerk

DocuSigned by:  
*Damon Phillips*  
11F90D87116B4F4...

10/10/2021

Approved as to Form: \_\_\_\_\_, Damon Phillips,  
Interim City Attorney

Final Passage and Vote: \_\_\_\_\_





# SUBD-PRE 21-003: Emerald Valley Phase 2

Item 11.

### Vicinity Map



- Legend**
- Emerald Valley Phase 2
  - Parcels
  - Sinkhole
  - Floodplain

Parcel Owner: Bester Properties LLC  
Parcel Address: 1300 Block of N. Main St.  
Area: 48 Acres  
Zoning: Single Family Medium Density Residential (R1-M)  
No. of Lots: 145

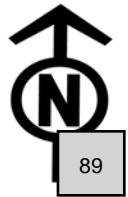
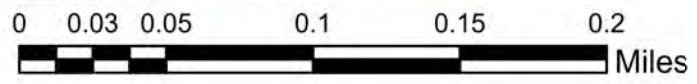

# SUBD-PRE 21-003: Emerald Valley Phase 2

Item 11.

## Zoning Map

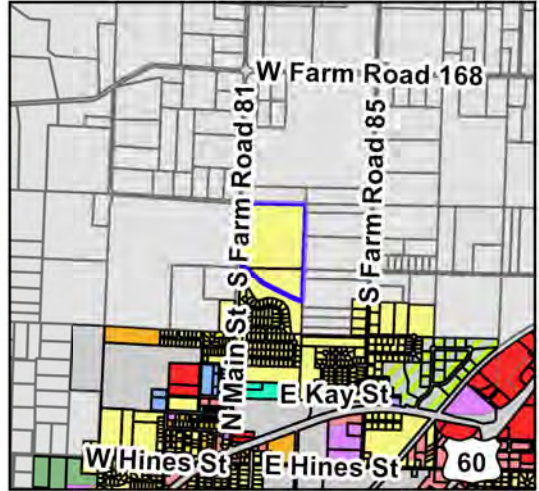

### Legend

- Emerald Valley Phase 2
  - Parcels
- ### Zoning
- AG Agricultural
  - C-1 Commercial
  - C-2 General Commercial
  - C-3 General Commercial
  - M-1 Light Manufacturing
  - M-2 Heavy Manufacturing
  - PDD Planned Development
  - R1-L Single Family Low Density
  - R1-M Single Family Medium Density
  - R1-H Single Family High Density
  - R1-Z Zero Lot Line Residential
  - R-2 Two-family Residential
  - R-3 Multi-family Residential

Parcel Owner: Bester Properties LLC  
 Parcel Address: 1300 Block of N. Main St.  
 Area: 48 Acres  
 Zoning: Single Family Medium Density Residential (R1-M)  
 No. of Lots: 145

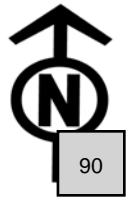
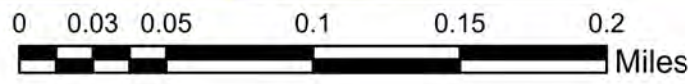

# Findings of Fact

Date of Hearing:

10/12/2021

Time:

6:00PM

Type of Application:

Other

Name of Applicant:

Bester Properties LLC - for Emerald Valley Ph 2

Location:

City Council Chambers

**Based upon the facts presented during the course of this hearing, I have found that the application is generally:**

- Conforming to the City's adopted Land Use Plan  Yes  No
- Conforming to the City's adopted Transportation Plan  Yes  No
- Conforming to other adopted plans of the City (i.e. water, wastewater, parks, etc.)  Yes  No
- Compatible with surrounding land uses  Yes  No
- Able to be adequately served by municipal infrastructure  Yes  No
- Aligned with the purposes of RSMo. 89.040  Yes  No

**Statement of Relevant Facts Found:**

No info given to deny this plat

**Based on these findings, I have concluded to recommend the application to the City Council for:**

Approval  Denial

Commissioner Name:

Brandon Andrews

Commissioner Signature:



Date:

10/12/2021

# Findings of Fact

Date of Hearing:

10/12/2021

Time:

6:00PM

Type of Application:

Other

Name of Applicant:

Bester Properties LLC - for Emerald Valley Ph 2

Location:

City Council Chambers

Based upon the facts presented during the course of this hearing, I have found that the application is generally:

- Conforming to the City's adopted Land Use Plan  Yes  No
- Conforming to the City's adopted Transportation Plan  Yes  No
- Conforming to other adopted plans of the City (i.e. water, wastewater, parks, etc.)  Yes  No
- Compatible with surrounding land uses  Yes  No
- Able to be adequately served by municipal infrastructure  Yes  No
- Aligned with the purposes of RSMo. 89.040  Yes  No

## Statement of Relevant Facts Found:

Already zoned (R1 - m)  
Speed limit change is up to Greene County  
Developer pays for shoulder left turn lane

Based on these findings, I have concluded to recommend the application to the City Council for:

Approval  Denial

Commissioner Name:

Kevin Haun

Commissioner Signature:

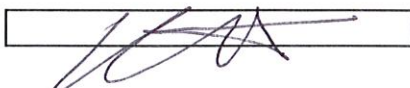

Date:

10/12/21

# Findings of Fact

Date of Hearing:

10/12/2021

Time:

6:00PM

Type of Application:

Other

Name of Applicant:

Bester Properties LLC - for Emerald Valley Ph 2

Location:

City Council Chambers

Based upon the facts presented during the course of this hearing, I have found that the application is generally:

- Conforming to the City's adopted Land Use Plan  Yes  No
- Conforming to the City's adopted Transportation Plan  Yes  No
- Conforming to other adopted plans of the City (i.e. water, wastewater, parks, etc.)  Yes  No
- Compatible with surrounding land uses  Yes  No
- Able to be adequately served by municipal infrastructure  Yes  No
- Aligned with the purposes of RSMo. 89.040  Yes  No

## Statement of Relevant Facts Found:

Speed Limit change? Set by Greene County

Water main 10"-8"? Not applicable to this approval

Based on these findings, I have concluded to recommend the application to the City Council for:

Approval  Denial

Commissioner Name:

Brian DeBrowe

Commissioner Signature:



Date:

10-12-21

# Findings of Fact

Date of Hearing:

10/12/2021

Time:

6:00PM

Type of Application:

Other

Name of Applicant:

Bester Properties LLC - for Emerald Valley Ph 2

Location:

City Council Chambers

**Based upon the facts presented during the course of this hearing, I have found that the application is generally:**

- Conforming to the City's adopted Land Use Plan  Yes  No
- Conforming to the City's adopted Transportation Plan  Yes  No
- Conforming to other adopted plans of the City (i.e. water, wastewater, parks, etc.)  Yes  No
- Compatible with surrounding land uses  Yes  No
- Able to be adequately served by municipal infrastructure  Yes  No
- Aligned with the purposes of RSMo. 89.040  Yes  No

**Statement of Relevant Facts Found:**

[Empty box for Statement of Relevant Facts Found]

**Based on these findings, I have concluded to recommend the application to the City Council for:**

Approval  Denial

Commissioner Name:

CYNTHIA HYDER

Commissioner Signature:

C. Hyder

Date:

10/12/21

# Findings of Fact

Date of Hearing:

10/12/2021

Time:

6:00PM

Type of Application:

Other

Name of Applicant:

Bester Properties LLC - for Emerald Valley Ph 2

Location:

City Council Chambers

Based upon the facts presented during the course of this hearing, I have found that the application is generally:

- Conforming to the City's adopted Land Use Plan  Yes  No
- Conforming to the City's adopted Transportation Plan  Yes  No
- Conforming to other adopted plans of the City (i.e. water, wastewater, parks, etc.)  Yes  No
- Compatible with surrounding land uses  Yes  No
- Able to be adequately served by municipal infrastructure  Yes  No
- Aligned with the purposes of RSMo. 89.040  Yes  No

### Statement of Relevant Facts Found:

[Empty box for Statement of Relevant Facts Found]

Based on these findings, I have concluded to recommend the application to the City Council for:

- Approval  Denial

Commissioner Name:

RAWSON ELLIS

Commissioner Signature:

[Handwritten Signature]

Date:

10/12/21

# Findings of Fact

Date of Hearing:

10/12/2021

Time:

6:00PM

Type of Application:

Other

Name of Applicant:

Bester Properties LLC - for Emerald Valley Ph 2

Location:

City Council Chambers

Based upon the facts presented during the course of this hearing, I have found that the application is generally:

- Conforming to the City's adopted Land Use Plan  Yes  No
- Conforming to the City's adopted Transportation Plan  Yes  No
- Conforming to other adopted plans of the City (i.e. water, wastewater, parks, etc.)  Yes  No
- Compatible with surrounding land uses  Yes  No
- Able to be adequately served by municipal infrastructure  Yes  No
- Aligned with the purposes of RSMo. 89.040  Yes  No

### Statement of Relevant Facts Found:

A side walk will be connected from Emerald Phase 1 to Phase 2.

Based on these findings, I have concluded to recommend the application to the City Council for:

Approval  Denial

Commissioner Name:

Darran Campbell

Commissioner Signature:

Darran Campbell

Date:

10-12-21





## AGENDA ITEM ANALYSIS

Project/Issue Name: 21-R-50 A Resolution of the City Council of the City of Republic, Missouri, Authorizing Execution of a Public Donation Agreement Accepting Real Property from Convoy of Hope.

Submitted By: Andrew Nelson, BUILDS Administrator

Date: Tuesday, October 19, 2021

### Issue Statement

A resolution to authorize the City to enter into an agreement to receive property from Convoy of Hope.

### Discussion and/or Analysis

The City wishes to enter into an agreement with Convoy of Hope to receive approximately 3.12 acres of real property located at 7200 Farm Road 144 for public purposes including the potential construction of a water tower and corresponding well and associated utility improvements. In exchange for the parcel, Convoy of Hope would be allowed to place its logo on said tower. If the City does not utilize the property for a water tower and well, it may revert to Convoy of Hope, but the City can also opt to purchase it.

### Recommended Action

Staff recommends approval.

**A RESOLUTION OF THE CITY COUNCIL OF THE CITY OF REPUBLIC, MISSOURI, AUTHORIZING EXECUTION OF A PUBLIC DONATION AGREEMENT ACCEPTING REAL PROPERTY FROM CONVOY OF HOPE**

*WHEREAS*, the City of Republic, Missouri, (herein called the “City” or “Republic”) is a municipal corporation and Charter City located in Greene County, Missouri, being duly created, organized, and existing under the laws of the State of Missouri; and

*WHEREAS*, Convoy of Hope is a foreign not for profit corporation in good standing which owns certain real property as described in Exhibit 1; and

*WHEREAS*, Convoy of Hope desires to dedicate the referenced real property to the City for public purpose, which may include construction of a water tower, and which may bear a logo from Convoy of Hope, with a possibility of reversion to Convoy of Hope or retention by the City, all as described in Exhibit 1; and

***NOW, THEREFORE, BE IT RESOLVED BY THE CITY COUNCIL OF THE CITY OF REPUBLIC, MISSOURI, AS FOLLOWS:***

- Section 1. The submitted attached proposed Public Donation Agreement as attached in Exhibit 1 is accepted.
- Section 2. On behalf of the City, the City Administrator is authorized to enter into an agreement substantially in the form as attached.
- Section 3. The City Administrator is authorized on behalf of the City to take the steps necessary to execute this Resolution.
- Section 4. The whereas clauses are hereby specifically incorporated herein by reference.
- Section 5. This Resolution will become effective on and after the date of passage and approval as provided by law.

***PASSED AND APPROVED*** at a regular meeting of the City Council of the City of Republic, Missouri, this 19th day of October 2021.

\_\_\_\_\_  
Matt Russell, Mayor

Attest:

\_\_\_\_\_  
Laura Burbridge, City Clerk

DocuSigned by:  
*Damon Phillips*  
11E90D87116B4E4

Approved as to Form: \_\_\_\_\_, 10/14/2021, Damon Phillips, City Attorney

Final Passage and Vote: \_\_\_\_\_

## PUBLIC DONATION AGREEMENT

This Public Donation Agreement is made and entered into as of the \_\_\_\_\_ day of \_\_\_\_\_, 2021, by and between the City of Republic, Missouri (the City) and Convoy of Hope, a foreign nonprofit corporation in good standing (Convoy of Hope); (collectively, the “Parties”).

## RECITALS:

- A. Convoy of Hope owns an approximately 3.12 acre property generally located at 7200 W. Farm Road 144 (the Parcel) as described in Exhibit 1.
- B. Convoy of Hope desires to donate the Parcel to the City for public purpose, as authorized by law, under the condition that Convoy of Hope be permitted to add its logo to the water tower.
- C. The City acknowledges that the Parcel is a donation, and that Convoy of Hope has not and will not be provided a direct financial benefit as a condition of the donation.
- D. On \_\_\_\_\_, 2021, the City Council of the City adopted \_\_\_\_\_ authorizing the City to enter into this Agreement.

NOW, THEREFORE, in consideration of the premises and other good and valuable consideration, the receipt and adequacy of which are hereby acknowledged and agreed, the City and Convoy of Hope agree as follows:

1. **Conveyance.** The City will provide Convoy of Hope with a general warranty deed in customary form to be executed by Convoy of Hope in order to dedicate the Parcel referenced herein to the City, which deed will be recorded by the City within 30 days of receipt from Convoy of Hope.
2. **Water Tower.** The City will hold the Parcel to use for public purpose, including until such a time as it may choose to use the parcel for a water tower. If the City uses the Parcel for a water tower, then it will allow Convoy of Hope to paint its logo and/or the words “Convoy of Hope” on the water tower. The City will also allow Convoy of Hope to maintain or repaint their logo and/or the words “Convoy or Hope” as reasonably necessary. Any alternative logos or anything else Convoy of Hope desires to paint on the water tower must be approved by the City.
3. **Reversion.** The City shall have a ten-year “Construction Period” from the date of this Agreement in which to build a water tower, which will begin on the date of the signing of this contract. The Parties agree that if the Parcel is not used for a water tower within the Construction Period, then Convoy of Hope will have the right to the title to the Parcel. Specifically, at the end of the Construction Period, if Convoy of Hope has not been permitted to add their logo to a water tower on the Parcel, Convoy of Hope is entitled to the title to the Parcel. A demand for title must be made at least 90 days prior to the expiration of the Construction Period, and if Convoy of Hope is permitted to add its logo to a water tower on the parcel prior to the expiration of the Construction Period, then the demand is void.

If the Construction Period ends and Convoy of Hope has not demanded title to the Parcel, then the Construction Period will be extended for 2 years, and Convoy of Hope will be able to demand title to the parcel as late as 90 days prior to the end of the extended Construction Period on the same

terms as though it were the original Construction Period. If no such demand is made, then the Construction Period may be extended automatically to as long as 20 years total without any further written agreement.

4. **Limitations on Reversion.** If Convoy of Hope demands the title to the Parcel while construction of a water tower is ongoing, the City may, upon notification of Convoy of Hope, extend the Construction Period by two years.
5. **Optional Payment in Lieu of Reversion and Exclusion of Remedies.** In the event of breach of this Agreement by the City the City may opt to retain title to the Parcel and to pay Convoy of Hope the fair market value of the Parcel in exclusion of all other remedies Convoy of Hope may have at the time or that may arise later, and the Parties will then be free of all future obligations under this Agreement. The City may exercise this option by providing written notice to Convoy of Hope. Fair market value will be determined as of the date notice is submitted to Convoy of Hope, and in an amount agreed upon by the Parties or determined by a court of proper jurisdiction.
6. **Public Donation.** As referenced herein, the City acknowledges the Parcel is a donation, and will take such steps as are reasonably necessary to document that Convoy of Hope has not and will not be provided a direct financial benefit as a condition of the donation.
7. **Term.** This contract shall be terminated and the City shall have no further obligations under this contract:
  - a. If no Convoy of Hope logo has been added to a water tower on the Parcel, then 20 years after the signing of the contract;
  - b. Ten years after the Convoy of Hope Logo shall be added to a water tower on the Parcel;
  - c. At such time as a water tower on the Parcel shall be destroyed, abandoned, or taken down;  
or
  - d. At such time as the City may return title to the Parcel to Convoy of Hope by warranty deed.
8. **Entire Agreement.** The Parties acknowledge that there may be subsequent agreements related to the matters referenced herein; however, this Agreement is the entire agreement to date between the Parties, and any changes of other terms or conditions must be in writing and approved by the Parties.
9. **Jurisdiction and Venue:** This Agreement shall be governed by the laws of the State of Missouri and venue as to any disputes related to this Agreement shall be Circuit Court of Greene County, Missouri.
10. **Liability:** Nothing in this Agreement shall be construed to create any liability on behalf of the City for any direct, special, indirect, liquated, consequential damages, or attorney fees.
11. **Indemnification:** Missouri law does not allow a governmental entity to indemnify a private company. The City will not defend, indemnify, or hold harmless Convoy of Hope, its officers, agents, successors, assigns, or any other individual or entity, and this Agreement shall not be construed to require any such obligation.
12. **Attorney Fees:** No attorney fees shall be assessed against the City for any matter related to this Agreement.
13. **Headings:** The headings in this Agreement are for convenience of reference only and shall not limit or otherwise affect the meaning thereof.

- 14. **Assignment:** This Agreement may not be assigned by any party without the prior written consent of the other parties.
- 15. **Public Entity and Officer Immunity and Defenses:** In no event shall the language or requirements of this Agreement constitute or be construed as a waiver or limitation of any rights or defenses with regard to applicable sovereign, governmental, official, or any individual immunities and any other protections or defenses as provided by federal and state constitutions, statutes, and laws. The procurement and maintenance of insurance shall not be construed as waiving any such defense otherwise available.
- 16. **Severability Clause:** A determination of invalidity or unconstitutionality by a court of competent jurisdiction of any clause, sentence, paragraph, section or part, of this Agreement shall not affect the validity of the remaining parts to this Agreement.
- 17. **Contingent Upon Funds and Approval:** To the extent that this Agreement calls for the expenditure of funds by the City it is contingent upon the City having sufficient funds available for the subject of this Agreement and this Agreement is subject to and conditioned upon approval by ordinance by the City Council.
- 18. **Notices:** Any notice, request or demand provided for in this Agreement shall be deemed to have been given when the same shall have been personally delivered to the following offices or deposited in the United States Mail, Registered or Certified, with postage thereon prepaid as follows:

City of Republic, Missouri Attn: City Administrator 213 North Main  
Street Republic, Missouri 65738

The Registered Agent for Convoy of Hope at the time of Notice, or its  
last Registered Agent with the Missouri Secretary of State.

**IN WITNESS WHEREOF**, the Parties have caused this to be signed by their duly authorized representatives, the day and year set forth below.

**Convoy of Hope**

\_\_\_\_\_  
Signature

Dated: \_\_\_\_\_

\_\_\_\_\_  
Printed Name and title

**City of Republic, Missouri**

\_\_\_\_\_  
David Cameron, City Administrator

Dated: \_\_\_\_\_

\_\_\_\_\_  
Attest: Laura Burbridge, City Clerk

Approved as to form:

\_\_\_\_\_  
Damon Phillips, City Attorney

## Exhibit 1

Convoy of Hope currently owns the Parcel with a legal description as follows:

A TRACT OF LAND BEING A PART OF THE SOUTHEAST QUARTER (SE<sup>1</sup>/<sub>4</sub>) OF THE NORTHEAST QUARTER (NE<sup>1</sup>/<sub>4</sub>) OF SECTION TWENTY-EIGHT (28), TOWNSHIP TWENTY-NINE (29) NORTH, RANGE TWENTY-THREE (23) WEST, GREENE COUNTY, MISSOURI, SAID TRACT OF LAND BEING MORE PARTICULARLY DESCRIBED AS FOLLOWS: COMMENCING AT AN EXISTING IRON PIN AT THE NORTHEAST CORNER OF THE NORTHEAST QUARTER (NE<sup>1</sup>/<sub>4</sub>) OF SAID NORTHEAST QUARTER (NE<sup>1</sup>/<sub>4</sub>); THENCE SOUTH 02°30'06" WEST, ALONG THE EAST LINE OF SAID NORTHEAST QUARTER (NE<sup>1</sup>/<sub>4</sub>) OF THE NORTHEAST QUARTER (NE<sup>1</sup>/<sub>4</sub>), A DISTANCE OF 1323.53 FEET TO AN IRON PIN SET AT THE NORTHEAST CORNER OF SAID SOUTHEAST QUARTER (SE<sup>1</sup>/<sub>4</sub>) OF THE NORTHEAST QUARTER (NE<sup>1</sup>/<sub>4</sub>) FOR A POINT OF BEGINNING; THENCE SOUTH 02°30'06" WEST, ALONG THE EAST LINE OF SAID SOUTHEAST QUARTER (SE<sup>1</sup>/<sub>4</sub>) OF THE NORTHEAST QUARTER (NE<sup>1</sup>/<sub>4</sub>), A DISTANCE OF 692.15 FEET TO AN IRON PIN SET ON THE EXISTING MISSOURI HIGHWAY AND TRANSPORTATION COMMISSION RIGHT-OF-WAY FOR FARM ROAD 97; THENCE NORTH 87°46'37" WEST, ALONG SAID EXISTING RIGHT-OF-WAY LINE, A DISTANCE OF 12.36 FEET TO AN EXISTING 1000 NAIL ON THE EXISTING WEST RIGHT-OF-WAY LINE OF SAID FARM ROAD 97; THENCE ALONG THE EXISTING MISSOURI HIGHWAY AND TRANSPORTATION COMMISSION WEST RIGHT-OF-WAY LINE OF FARM ROAD 97 THE FOLLOWING THREE COURSES; 1) THENCE SOUTH 12°08'15" WEST, A DISTANCE OF 83.13 FEET TO AN IRON PIN SET; 2) THENCE SOUTH 06°49'33" WEST, A DISTANCE OF 82.36 FEET TO AN EXISTING 100D NAIL; 3) THENCE SOUTH 00°16'35" WEST, A DISTANCE OF 102.71 FEET TO AN EXISTING 100D NAIL, SAID POINT BEING ON THE EAST RIGHT-OF-WAY OF MISSOURI HIGHWAY 360; THENCE ALONG THE EAST RIGHT-OF-WAY LINE OF SAID MISSOURI HIGHWAY 360 THE FOLLOWING SIX COURSES; 1) THENCE NORTH 25°06'15" WEST, A DISTANCE OF 60.32 FEET TO AN EXISTING 1000 NAIL; 2) THENCE NORTH 21°24'16" WEST, A DISTANCE OF 235.51 FEET TO AN IRON PIN SET; 3) THENCE NORTH 09°22'29" WEST, A DISTANCE OF 250.31 FEET TO AN IRON PIN SET; 4) THENCE NORTH 04°48'59" EAST, A DISTANCE OF 196.02 FEET TO AN EXISTING 100D NAIL; 5) THENCE NORTH 14°09'11" EAST, A DISTANCE OF 170.14 FEET TO AN EXISTING 100D NAIL; 6) THENCE NORTH 27°23'13" EAST, A DISTANCE OF 89.73 FEET TO AN IRON PIN SET ON THE NORTH LINE OF SAID SOUTHEAST QUARTER (SE<sup>1</sup>/<sub>4</sub>) OF THE NORTHEAST QUARTER (NE<sup>1</sup>/<sub>4</sub>); THENCE SOUTH 88°06'39" EAST, ALONG THE NORTH LINE OF SAID SOUTHEAST QUARTER (SE<sup>1</sup>/<sub>4</sub>) OF THE NORTHEAST QUARTER (NE<sup>1</sup>/<sub>4</sub>), A DISTANCE OF 123.37 FEET TO THE POINT OF BEGINNING.



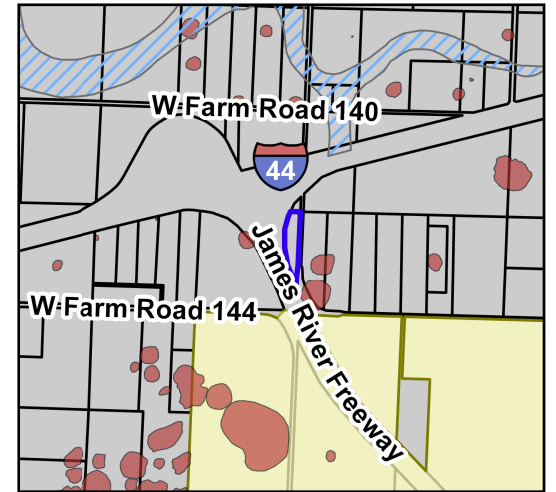
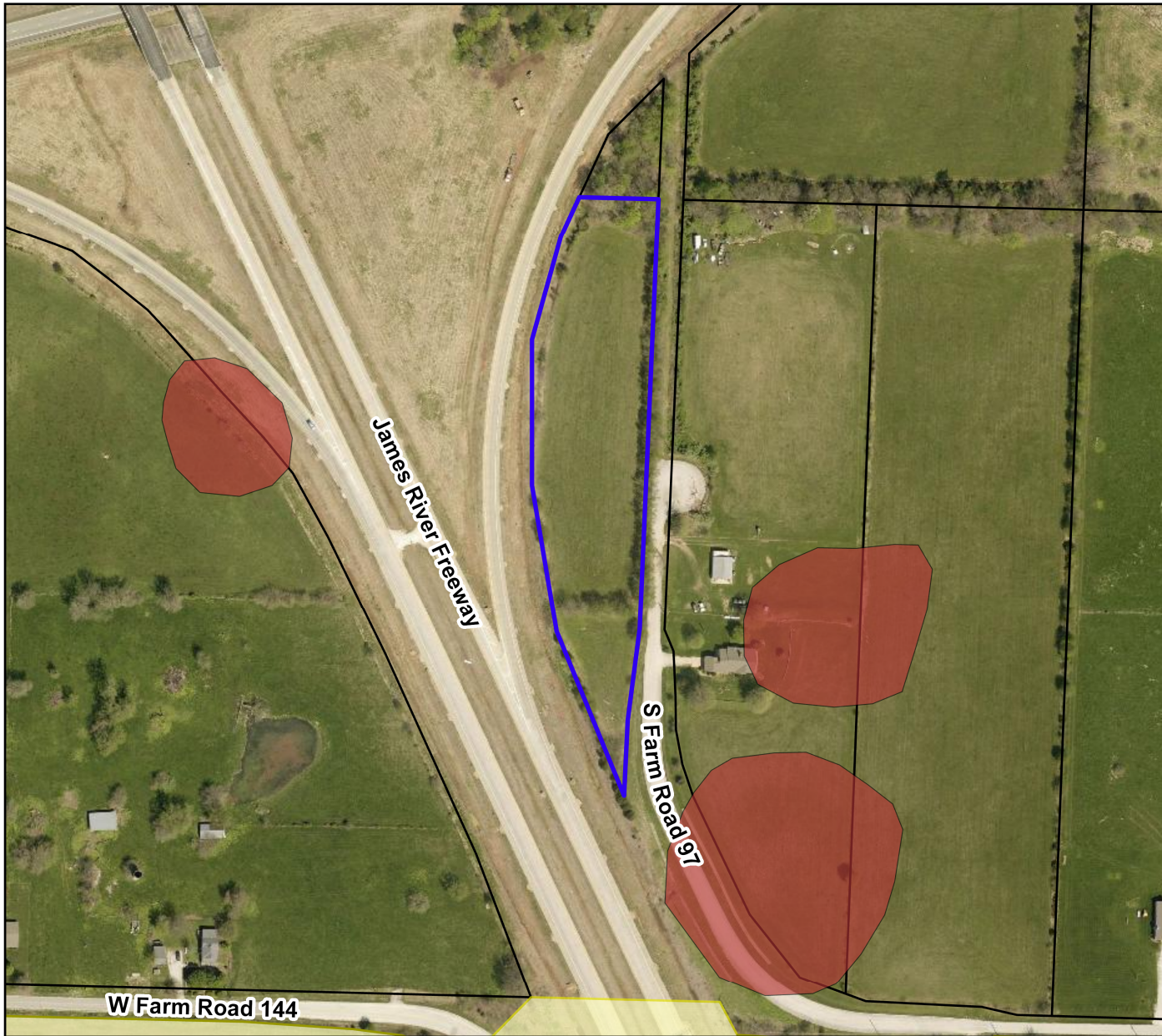

# Convoy of Hope Property for City Agreement

Item 12.

## Vicinity Map



### Legend

-  Convoy Agreement Property
-  Parcels
-  Republic City Limits
-  Sinkhole
-  Floodplain

Parcel Owner: Convoy of Hope  
Parcel Id No.: 881428100025  
Area: 3.12 Acres  
Jurisdiction: Greene County

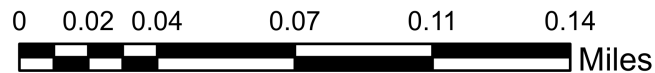





## AGENDA ITEM ANALYSIS

Project/Issue Name: 21-R-51 A Resolution of the City Council of the City of Republic, Missouri, Authorizing the Execution of a Fourth Amendment to Communication Lease Agreement with New Cingular Wireless PCS, LLC.

Submitted By: Andrew Nelson, BUILDS Administrator

Date: October 19, 2021

### Issue Statement

To approve the fourth amendment to Option Tower and Ground Space Lease with AT&T.

### Discussion and/or Analysis

In 2003, the city approved an agreement with New Cingular Wireless PCS, LLC (AT&T) allowing them to lease space on City property in order to place cellular antennas and all required equipment for operation. This lease automatically renews on 5-year terms unless the City chooses to opt out of it. The new term will begin on June 1, 2023 and will be automatically renewed for up to five additional 5-year terms.

This fourth amendment is to allow the Tenant to cancel the agreement within 60 days of renewal date and allows modification of rent beginning June 1, 2023. Monthly rent will be \$1,900.00 (\$22,800.00 annually) and will increase by 10% at the beginning of each 5-year extension term. In addition, this amendment also includes a fair and equitable agreement related to utility charges toward the tenant.

### Recommended Action

Staff recommends approval of the amendment.

**A RESOLUTION OF THE CITY COUNCIL OF THE CITY OF REPUBLIC, MISSOURI, AUTHORIZING EXECUTION OF THE FOURTH AMENDMENT TO COMMUNICATION LEASE AGREEMENT WITH NEW CINGULAR WIRELESS PCS, LLC**

*WHEREAS*, the City of Republic, Missouri, (herein called the "City" or "Republic") is a municipal corporation and Charter City located in Greene County, Missouri, being duly created, organized, and existing under the laws of the State of Missouri; and

*WHEREAS*, the City has an existing lease agreement ("Agreement") with Cingular Wireless PCS, LLC ("Tenant") for lease of a portion of City property located in the area of 687 East Hines Street, Republic, MO 65738; and

*WHEREAS*, in the City and Tenant desire to amend the Agreement as described in the attached Exhibit 1, including to extend the terms, adjust the rent, and clarify the scope of Tenant's permitted use, and to revise the notice requirements.

***NOW, THEREFORE, BE IT RESOLVED BY THE CITY COUNCIL OF THE CITY OF REPUBLIC, MISSOURI, AS FOLLOWS:***

- Section 1. The submitted attached proposed Fourth Amendment to Communication Lease Agreement as attached Exhibit 1 is accepted.
- Section 2. On behalf of the City, the Mayor is authorized to enter into an agreement in the form as attached.
- Section 3. The City Administrator is authorized on behalf of the City to take the steps necessary to execute this Resolution.
- Section 4. The whereas clauses are hereby specifically incorporated herein by reference.
- Section 5. This Resolution will become effective on and after the date of passage and approval as provided by law.

***PASSED AND APPROVED*** at a regular meeting of the City Council of the City of Republic, Missouri, this day of October 2021.

\_\_\_\_\_  
Matt Russell, Mayor

Attest:

\_\_\_\_\_  
Laura Burbridge, City Clerk

DocuSigned by:  
*Damon Phillips*  
11E90D87116B4F4

10/10/2021

Approved as to Form: \_\_\_\_\_, Damon Phillips,  
Interim City Attorney

Final Passage and Vote: \_\_\_\_\_

Market: KS / MO  
 Cell Site Number: KS4308  
 Cell Site Name: Republic DT  
 Fixed Asset Number: 10041071

#### FOURTH AMENDMENT TO COMMUNICATION LEASE AGREEMENT

THIS FOURTH AMENDMENT TO COMMUNICATION LEASE AGREEMENT (“**Amendment**”) dated as of the later date below is by and between City of Republic, Missouri, having a mailing address at 213 North Main Avenue, Attn: City Administrator, Republic, MO 65738 (“**Landlord**”) and New Cingular Wireless PCS, LLC, a Delaware limited liability company, having a mailing address at 1025 Lenox Park Blvd NE, 3rd Floor, Atlanta, GA 30319 (“**Tenant**”).

WHEREAS, Landlord and Tenant (or its affiliate or predecessor-in-interest) entered into a Communication Lease Agreement (“**Original Lease**”) dated January 17, 2003, as amended by Amendment to Lease Agreement (“**First Amendment to Communication Lease Agreement**”) dated April 1, 2003, as amended by Amendment to Lease Agreement (“**Second Amendment to Communication Lease Agreement**”) date unknown, and as amended by Third Amendment to Lease Agreement (“**Third Amendment to Communication Lease Agreement**”) dated December 2, 2010, , whereby Landlord leased to Tenant certain Leased Premises, therein described, that are a portion of the property (“**Property**”) located at 687 East Hines Street, Republic, MO 65738 (collectively, the “**Agreement**”); and

WHEREAS, Landlord and Tenant desire to amend the Agreement to extend the term of the Agreement; and

WHEREAS, Landlord and Tenant desire to adjust the Rent in conjunction with the modifications to the Agreement contained herein; and

WHEREAS, Landlord and Tenant desire to amend the Agreement to clarify the scope of Tenant's permitted use of the Leased Premises; and

WHEREAS, Landlord and Tenant, desire to amend the Agreement to modify the notice section thereof; and

WHEREAS, Landlord and Tenant, in their mutual interest, wish to amend the Agreement as set forth below accordingly.

NOW THEREFORE, in consideration of the foregoing and other good and valuable consideration, the receipt and sufficiency of which are hereby acknowledged, Landlord and Tenant agree as follows:

1. **Term.** The term of the Agreement shall be amended to provide that the Agreement has a new initial term of five (5) years (“**New Initial Term**”), commencing on June 1, 2023, (“**New Term Commencement Date**”). As of such New Term Commencement Date, all remaining extension Terms in the Agreement except as set forth herein shall be void and of no further force and consequence. The Agreement will be automatically renewed for up to five (5) additional five (5) year terms (each an “**Extension Term**”) upon the same terms and conditions of the Agreement, as amended herein, without further action by Tenant, unless Tenant notifies Landlord in writing of Tenant’s intention not to renew the Agreement at least sixty (60) days prior to the expiration of the New Initial Term or the then current Extension Term. Hereafter, the defined term “**Term**” shall include the New Initial Term and any applicable Extension Term. Landlord agrees and acknowledges that except that as such permitted use or other rights may be amended herein, Tenant may continue to use and exercise its rights under the Agreement as permitted prior to the New Initial Term.

2. **Modification of Rent.** Commencing on June 1, 2023, the current rent payable under the Agreement shall be One Thousand Nine Hundred and No/100 Dollars (\$1,900.00) per month (the “**Rent**”), and shall continue during the Term, subject to adjustment, if any, as provided below. In the event of any overpayment of Rent prior to or after the Effective Date, Tenant shall have the right to deduct from any future Rent payments an amount equal to the overpayment amount.

3. **Future Rent Increase / Extension Term Increase.** The Agreement is amended to provide that commencing on June 1, 2028, Rent shall increase by ten percent (10%) and at the beginning of each Extension Term, as applicable.

4. **Permitted Use.** Tenant, its personnel, invitees, contractors, agents, or assigns may use the Leased Premises, at no additional cost or expense, for the transmission and reception of any and all communications signals and, with prior written notice to landlord, to modify, supplement, replace, upgrade, expand, including but not limited to the number and type(s) of antennas, or refurbish the equipment and/or improvements thereon or relocate the same within the Leased Premises at any time during the term of the Agreement for any reason, so long as these changes do not exceed the structural capacity of the tower/structure at this height, or in order to be in compliance with any current or future federal, state or local mandated application, including but not limited to emergency 911 communication services, or for any other reason. Landlord shall reasonably cooperate in obtaining governmental and other use permits or approvals necessary or desirable for the foregoing permitted use. If Landlord does not comply with the terms of this section, in addition to any other rights it may have at law, Tenant may terminate the Agreement and shall have no further liability to Landlord. If Landlord does not comply with the terms of this section, Tenant will have the right to exercise any and all rights available to it under law and equity, including the right to cure Landlord's default and to deduct the costs of such cure from any monies due to Landlord from Tenant.

5. **Acknowledgement.** Landlord acknowledges that: 1) this Amendment is entered into of the Landlord's free will and volition; 2) Landlord has read and understands this Amendment and the underlying Agreement and, prior to execution of this Amendment, was free to consult with counsel of its choosing regarding Landlord's decision to enter into this Amendment and to have counsel review the terms and conditions of this Amendment; 3) Landlord has been advised and is informed that should Landlord not enter into this Amendment, the underlying Agreement between Landlord and Tenant, including any termination or non-renewal provision therein, would remain in full force and effect.

6. **Notices.** Article XV of the Agreement is hereby deleted in its entirety and replaced with the following:

**NOTICES.** All notices, requests, demands and communications hereunder will be given by first class certified or registered mail, return receipt requested, or by a nationally recognized overnight courier, postage prepaid, to be effective when properly sent and received, refused or returned undelivered. Notices will be addressed to the parties as follows.

If to Landlord:

City of Republic, Missouri  
Attn: City Administrator  
213 North Main Avenue  
Republic, MO 65738

If to Tenant:

New Cingular Wireless PCS, LLC  
Attn: TAG – LA  
Re: Cell Site #: KS4308  
Cell Site Name: Republic DT (MO)  
Fixed Asset #: 10041071  
1025 Lenox Park Blvd. NE  
3rd Floor  
Atlanta, GA 30319

With a copy to:

New Cingular Wireless PCS, LLC  
Attn: Legal Department  
Re: Cell Site #: KS4308  
Cell Site Name: Republic DT (MO)

Fixed Asset #: 10041071  
208 S. Akard Street  
Dallas, Texas, 75202-4206

The copy sent to the Legal Department is an administrative step which alone does not constitute legal notice. Either party hereto may change the place for the giving of notice to it by thirty (30) days prior written notice to the other as provided herein.

7. **Right of First Refusal.** Notwithstanding any other provisions contained in the Agreement, if at any time after the Effective Date, Landlord receives a bona fide written offer from a third party seeking any sale, conveyance, assignment or transfer, whether in whole or in part, of any property interest in or related to the Leased Premises, including without limitation any offer seeking an assignment or transfer of the Rent payments associated with the Agreement or an offer to purchase an easement with respect to the Leased Premises (“Offer”), Landlord shall immediately furnish Tenant with a copy of the Offer. Tenant shall have the right within ninety (90) days after it receives such copy to match the financial terms of the Offer and agree in writing to match such terms of the Offer. Such writing shall be in the form of a contract substantially similar to the Offer, but Tenant may assign its rights to a third party. If Tenant chooses not to exercise this right or fails to provide written notice to Landlord within the ninety (90) day period, Landlord may sell, convey, assign or transfer such property interest in or related to the Leased Premises pursuant to the Offer, subject to the terms of the Agreement. If Landlord attempts to sell, convey, assign or transfer such property interest in or related to the Leased Premises without complying with this Article 7, the sale, conveyance, assignment or transfer shall be void. Tenant shall not be responsible for any failure to make payments under the Agreement and reserves the right to hold payments due under the Agreement until Landlord complies with this Article 7. Tenant’s failure to exercise the right of first refusal shall not be deemed a waiver of the rights contained in this Article 7 with respect to any future proposed conveyances as described herein.

8. **Charges.** All charges payable under the Agreement such as utilities and taxes shall be billed by Landlord within one (1) year from the end of the calendar year in which the charges were incurred; any charges beyond such period shall not be billed by Landlord, and shall not be payable by Tenant. The foregoing shall not apply to monthly Rent which is due and payable without a requirement that it be billed by Landlord. The provisions of this subsection shall survive the termination or expiration of the Agreement.

9. **Other Terms and Conditions Remain.** In the event of any inconsistencies between the Agreement and this Amendment, the terms of this Amendment shall control. Except as expressly set forth in this Amendment, the Agreement otherwise is unmodified and remains in full force and effect. Each reference in the Agreement to itself shall be deemed also to refer to this Amendment.

10. **Capitalized Terms.** All capitalized terms used but not defined herein shall have the same meanings as defined in the Agreement.

[NO MORE TEXT ON THIS PAGE - SIGNATURES TO FOLLOW ON NEXT PAGE]

**IN WITNESS WHEREOF**, the parties have caused this Amendment to be effective as of the last date written below.

**LANDLORD:**  
City of Republic, Missouri

**TENANT:**  
New Cingular Wireless PCS, LLC,  
a Delaware limited liability company

By: AT&T Mobility Corporation  
Its: Manager

By: \_\_\_\_\_  
Print Name: \_\_\_\_\_  
Its: \_\_\_\_\_  
Date: \_\_\_\_\_

By: \_\_\_\_\_  
Print Name: \_\_\_\_\_  
Its: \_\_\_\_\_  
Date: \_\_\_\_\_

[REMAINDER OF PAGE INTENTIONALLY LEFT BLANK]