



**AGENDA
CITY OF CEDAR FALLS, IOWA
CITY COUNCIL MEETING
TUESDAY, JANUARY 17, 2023
7:00 PM AT CITY HALL, 220 CLAY STREET**

Call to Order by the Mayor

Roll Call

Pledge of Allegiance

Approval of Minutes

1. Regular meeting of January 3, 2023.

Agenda Revisions

Special Presentations

Public Forum. (Speakers will have one opportunity to speak for up to 5 minutes on topics relevant to City business.)

Staff Updates

Special Order of Business

2. Public hearing on the proposed FY2023-FY2028 Capital Improvements Program (CIP).
 - a) Receive and file proof of publication of notice of hearing. (Notice published January 6, 2023)
 - b) Written communication filed with the City Clerk.
 - c) Staff comments.
 - d) Public comments.
 - e) Resolution approving and adopting the FY2023-FY2028 Capital Improvements Program (CIP).
3. Resolution declaring an official intent under Treasury Regulation 1.150-2 to issue debt to reimburse the City for certain original expenditures paid in connection with specified projects. (contingent upon approval of previous item)
4. Public hearing on the proposed rezoning to R-4, Multiple Unit Residential Zoning District, pursuant to a Zoning Agreement, for property located on Lots 5 and 6, Midway Business Park.
 - a) Receive and file proof of publication of notice of hearing. (Notice published January 6, 2023)
 - b) Written communication filed with the City Clerk.
 - c) Staff comments.
 - d) Public comments.
 - e) Pass an ordinance amending the Zoning Map by placing property located on Lots 5 and 6 of the

Midway Business Park in the R-4, Multiple Unit Residential Zoning District, pursuant to provisions of a Zoning Agreement, upon its first consideration.

5. Public hearing on the proposed rezoning from R-4, Multiple Unit Residential, to R-1, One & Two Unit Residential, for Lots 1-4 of Midway Second Addition.
 - a) Receive and file proof of publication of notice of hearing. (Notice published January 6, 2023)
 - b) Written communication filed with the City Clerk.
 - c) Staff comments.
 - d) Public comments.
 - e) Pass an ordinance amending the Zoning Map by removing property generally described as Lots 1-4 of Midway Second Addition from the R-4, Multiple Unit Residential Zoning District, to the R-1, One & Two Unit Residential Zoning District, upon its first consideration.

Consent Calendar: (The following items will be acted upon by voice vote on a single motion without separate discussion, unless someone from the Council or public requests that a specific item be considered separately.)

6. Receive and file the City Council Work Session minutes of January 3, 2023 relative to the following items:
 - a) Council Policy Development.
7. Receive and file the City Council Standing Committee minutes of January 3, 2023 relative to the following items:
 - a) Annual Report of Library.
 - b) RETF items implemented by Public Safety.
8. Approve the following recommendations of the Mayor relative to the appointment of members to Boards and Commissions:
 - a) Shirley Merner, Health Trust Fund Board of Trustees, term ending 12/31/28.
9. Approve the following applications for retail alcohol licenses:
 - a) College Square Cinema, 6301 University Avenue, Special Class C retail alcohol - renewal.
 - b) Fraternal Order of Eagles, 2125 West Lone Tree Road, Class C retail alcohol & outdoor service - renewal.
 - c) Kwik Spirits, 4116 University Avenue, Class E retail alcohol - renewal.

Resolution Calendar: (The following items will be acted upon by roll call vote on a single motion without separate discussion, unless someone from the Council or public requests that a specific item be considered separately.)

10. Resolution Calendar with items considered separately.
11. Resolution approving and adopting amendments to the City's Accounting Policies and Procedures and Purchasing Manual.
12. Resolution approving and authorizing execution of a Contract with Exceptional Persons, Inc. (EPI) relative to Community Development Block Grant (CDBG) funding for service agencies.
13. Resolution approving the final plat of Wild Horse Ridge Sixth Addition.
14. Resolution approving and authorizing the expenditure of funds for the purchase of ultraviolet (UV) disinfection lamps for the Water Reclamation facility.
15. Resolution approving the Certificate of Completion and accepting the work of Aspro, Inc. for the College Hill Parking Lot Improvements Project.

- [16.](#) Resolution approving and authorizing execution of a License Agreement with Aureon Network Services relative to installing a fiber optic telecommunications system within the West 2nd Street public right-of-way.
- [17.](#) Resolution approving and authorizing execution of a License Agreement with Windstream Intellectual Property Services, LLC relative to installing a fiber optic telecommunications system within the West 12th Street and Union Road public right-of-way.
- [18.](#) Resolution approving and authorizing execution of an Owner Purchase Agreement; and approving and accepting one Temporary Construction Easement, in conjunction with the Oak Park Sanitary Sewer Repair Project.
- [19.](#) Resolution approving and accepting completion of public improvements in Wild Horse Ridge Fifth Addition.
- [20.](#) Resolution approving and accepting completion of public improvements in Wild Horse Ridge Sixth Addition.
- [21.](#) Resolution approving and accepting a Warranty Deed, in conjunction with the Main Street Reconstruction Project.
- [22.](#) Resolution receiving and filing, and setting February 6, 2023 as the date of public hearing on the proposed plans, specifications, form of contract & estimate of cost for the Hudson Road & West Ridgeway Avenue Intersection Improvements Project.
- [23.](#) Resolution receiving and filing, and setting February 6, 2023 as the date of public hearing on the proposed plans, specifications, form of contract & estimate of cost for the Oak Park Boulevard Sanitary Sewer Replacement Project.

Allow Bills and Claims

- [24.](#) Allow Bills and Claims for January 17, 2023.

Council Updates and Announcements

Council Referrals

Adjournment

**CITY HALL
CEDAR FALLS, IOWA, JANUARY 3, 2023
REGULAR MEETING, CITY COUNCIL
MAYOR ROBERT M. GREEN PRESIDING**

- The City Council of the City of Cedar Falls, Iowa, met in Regular Session, pursuant to law, the rules of said Council and prior notice given each member thereof, at 7:07 P.M. on the above date. Members present: Schultz (via phone), deBuhr, Kruse, Harding, Ganfield, Sires, Dunn. Absent: None. Mayor Green led the Pledge of Allegiance.
- 54093 - It was moved by Kruse and seconded by Harding that the minutes of the Regular Meeting of December 19, 2022 be approved as presented and ordered of record. Motion carried unanimously.
- 54094 - The Mayor then asked if there were any agenda revisions. City Clerk Danielsen noted that items 22, 28 and 29 on the Resolution Calendar were being removed from the agenda.
- 54095 - Tamie Stahl, 1009 Lakeshore Drive, spoke in support of Fire Chief Bostwick and requested his reinstatement. Mayor Green clarified that Chief Bostwick is currently on administrative leave and has not suspended.
- 54096 - City Administrator Gaines announced that an offer of employment has been made for the Diversity Equity Inclusion Specialist position.
- 54097 - Mayor Green announced that in accordance with the public notice of December 21, 2022, this was the time and place for a public hearing on the proposed FY2023-FY2028 Capital Improvements Program (CIP). It was then moved by Harding and seconded by Dunn that the proof of publication of notice of hearing be received and placed on file. Motion carried unanimously.
- 54098 - The Mayor then asked if there were any written communications filed to the proposed CIP. Upon being advised that there were no written communications on file, the Mayor then called for oral comments. Finance & Business Operations Director Rodenbeck provided a summary of the proposed CIP and budget process. There being no one else present wishing to speak about the CIP, the Mayor declared the hearing closed and passed to the next order of business.
- 54099 - It was moved by Dunn and seconded by Harding that a resolution approving and adopting the FY2023-FY2028 Capital Improvements Program (CIP), be adopted. Following comments and questions by Councilmembers deBuhr, Ganfield, Sires, and Kruse, and responses by City Administrator Gaines, Finance & Business Operations Director Rodenbeck and Public Works Director Schrage, the Mayor put the question on the motion and upon call of the roll, the following named Councilmembers voted. Aye: Schultz, Harding, Dunn. Nay: deBuhr, Kruse, Ganfield, Sires. Motion failed.
- 54100 - Mayor Green announced that in accordance with the public notice of December 22, 2022, this was the time and place for a public hearing on a proposed

Southwest Cedar Falls Urban Renewal Plan for a proposed urban renewal area. It was then moved by Ganfield and seconded by Harding that the proof of publication of notice of hearing be received and placed on file. Motion carried unanimously.

- 54101 - The Mayor then asked if there were any written communications filed to the proposed plan. Upon being advised that there were no written communications on file, the Mayor then called for oral comments. Economic Development Coordinator Graham provided a brief summary of the proposed Urban Renewal Plan. There being no one else present wishing to speak about the plan, the Mayor declared the hearing closed and passed to the next order of business.
- 54102 - It was moved by Kruse and seconded by deBuhr that Resolution #23,019, determining an area of the City to be an economic development area, and that the rehabilitation, conservation, redevelopment or a combination thereof, of such area is necessary in the interest of the public health, safety or welfare of the residents of the City; designating such area as appropriate for urban renewal projects; and adopting the Southwest Cedar Falls Urban Renewal Plan, be adopted. Following a question by Councilmember Ganfield and response by Economic Development Coordinator Graham, the Mayor put the question on the motion and upon call of the roll, the following named Councilmembers voted. Aye: Schultz, deBuhr, Kruse, Harding, Ganfield, Sires, Dunn. Nay: None. Motion Carried. The Mayor then declared Resolution #23,019 duly passed and adopted.
- 54103 - It was moved by Kruse and seconded by Harding that Resolution #23,020, approving and authorizing execution of an Offer to Buy Real Estate and Acceptance for real estate located at 6512 West Ridgeway Avenue relative to expansion of the West Viking Road Industrial Park, be adopted. Following due consideration by the Council, the Mayor put the question on the motion and upon call of the roll, the following named Councilmembers voted. Aye: Schultz, deBuhr, Kruse, Harding, Ganfield, Sires, Dunn. Nay: None. Motion Carried. The Mayor then declared Resolution #23,020 duly passed and adopted.
- 54104 - It was moved by deBuhr and seconded by Kruse to repass, over Mayor's veto, Ordinance #3021, amending Section 18-23(5), Powers and duties of the Planning and Zoning Commission, of the Code of Ordinances relative to removing 2/3 majority vote required by City Council to approve amendments to the City's comprehensive plan that are disapproved by the Planning and Zoning Commission. Following comments by Councilmembers deBuhr, Dunn, Ganfield, Harding, Schultz, Sires and Kruse, and Mayor Green, the Mayor put the question on the motion and upon call of the roll, the following named Councilmembers voted. Aye: deBuhr, Kruse, Ganfield, Sires. Nay: Schultz, Harding, Dunn. Motion failed due to requirement of five aye votes.
- 54105 - It was moved by Harding and seconded by Dunn to repass, over Mayor's veto, Ordinance #3022, amending Chapter 26, Zoning, of the Code of Ordinances relative to removing the 2/3 majority vote required by City Council to approve zoning amendments that are disapproved by the Planning and Zoning Commission. Following comments by Councilmember Ganfield, the Mayor put the question on the motion and upon call of the roll, the following named

Councilmembers voted. Aye: deBuhr, Kruse, Ganfield, Sires. Nay: Schultz, Harding, Dunn. Motion failed due to requirement of five aye votes.

- 54106 - It was moved by Harding and seconded by Ganfield that the following items on the Consent Calendar be received, filed and approved:

Receive and file the report of the Mayor relative to the appointment of Mayor Pro Tem for 2023.

Receive and file the report of the Mayor relative to the appointment of Standing Committees for 2023.

Receive and file the City Council Goal Setting Report of November 15 & 17, 2022.

Receive and file the City Council Standing Committee minutes of December 19, 2022 relative to the following items:

- a) Capital Improvements Program (CIP).
- b) Format of FY2024 City Council Goals, Work Program and Short-Term Financial Plan document.

Receive and file CFD 1123: Mayor Policy - Council Meeting Security and Good Order.

Receive and file the resignation of Don Timmerman as a member of the Housing Commission.

Receive and file Departmental Monthly Reports of November 2022.

Approve the following applications for retail alcohol licenses:

- a) Huhot Mongolian Grill, 6301 University Avenue, Special Class C retail alcohol - renewal.
- b) Hy-Vee Market Grille, 6301 University Avenue, Class C retail alcohol – change in ownership.
- c) Hy-Vee Food Store, 6301 University Avenue, Class E retail alcohol – change in ownership.
- d) AmericInn by Wyndham, 5818 Nordic Drive, Class B retail alcohol – new.
- e) Holiday Inn Express & Suites, 1614 Technology Parkway, Class B retail alcohol – new.
- f) Second State Brewing, 203 State Street, Class C retail alcohol & outdoor service – new.

Motion carried unanimously.

- 54107 - It was moved by Kruse and seconded by Harding to receive and file Disclosures of Potential Conflicts of Interest for elected officials. Following comments and questions by Councilmembers deBuhr, Sires and Dunn, and responses by Mayor Green, the motion carried 5-2, with deBuhr and Kruse voting Nay.

- 54108 - It was moved by Harding and seconded by Ganfield to receive and file CFD 1129: Mayor Policy - Administrator Performance Evaluation. Following a request by Councilmember deBuhr to replace the word “councilors” to “councilmembers”

throughout the document, the motion carried unanimously.

- 54109 - It was moved by Kruse and seconded by Dunn that the following resolutions be introduced and adopted:

Resolution #23,021, approving and adopting amendments to Personnel Policy 307: Overtime, for the City of Cedar Falls.

Resolution #23,022, levying a final assessment for costs incurred by the City to mow the property located at 323 West 2nd Street.

Resolution #23,023, levying a final assessment for costs incurred by the City to mow the property located at 829 Lilac Lane.

Resolution #23,024, approving and authorizing execution of an Agreement for the Use of State or Local Overtime and Authorized Expense/Strategic Initiative Program for Organized Crime Drug Enforcement Task Force (OCDETF) for FY2023, Case #WC-IAN-139.

Resolution #23,025, approving and authorizing execution of an Agreement for the Use of State or Local Overtime and Authorized Expense/Strategic Initiative Program for Organized Crime Drug Enforcement Task Force (OCDETF) for FY2023, Case #WC-IAN-136.

Resolution #23,026, approving and authorizing execution of a Travel Iowa Data Co-op Agreement with the Iowa Economic Development Authority (IEDA) relative to access to statewide and localized visitation data.

Resolution #23,027, approving and authorizing execution of an Owner Purchase Agreement; and approving and accepting one Temporary Construction Easement, in conjunction with the Main Street Reconstruction Project.

Resolution #23,028, approving and accepting two Warranty Deeds, in conjunction with the Main Street Reconstruction Project.

Resolution #23,029, setting January 17, 2023 as the date of public hearing on the proposed rezoning to R-4, Multiple Unit Residential, and associated zoning agreement for property located on Greenhill Circle, Midway Business Park.

Resolution setting #23,030, January 17, 2023 as the date of public hearing on the proposed rezoning from R-4, Multiple Unit Residential, to R-1, One & Two Unit Residential, for Lots 1-4, Midway Second Addition.

Following due consideration by the Council, the Mayor put the question on the motion and upon call of the roll, the following named Councilmembers voted. Aye: Schultz, Kruse, Harding, Ganfield, Sires, Dunn. Nay: deBuhr. Motion carried. The Mayor then declared Resolutions #23,021 through #23,030 duly passed and adopted.

- 54110 - It was moved by Dunn and seconded by Harding that Resolution #23,031, approving and adopting the FY2024 City Council Goals, Work Program and Short-Term Financial Plan, be adopted. Following due consideration by the

Council, the Mayor put the question on the motion and upon call of the roll, the following named Councilmembers voted. Aye: Schultz, Harding, Ganfield, Dunn. Nay: deBuhr, Kruse, Sires. Motion Carried. The Mayor then declared Resolution #23,031 duly passed and adopted.

54111 - It was moved by Kruse and seconded by Harding that Resolution #23,032, approving and authorizing execution of a Services Agreement with Cope Murphy + Co. LLP relative to providing lobbyist services relative to legislative action, be adopted. Following comments and questions by Councilmembers Kruse and deBuhr, and responses by Finance & Business Operations Director Rodenbeck and Mayor Green, the Mayor put the question on the motion and upon call of the roll, the following named Councilmembers voted. Aye: deBuhr, Kruse, Harding, Dunn. Nay: Schultz, Ganfield, Sires. Motion Carried. The Mayor then declared Resolution #23,032 duly passed and adopted.

54112 - It was moved by Dunn and seconded by Harding that Resolution #23,033, approving a C-1, Commercial Zoning District site plan for construction of a triplex to be located on Lot 4, Hannah Park Commercial Addition, be adopted. Following a question by Councilmember deBuhr and response by Planning & Community Services Manager Howard, the Mayor put the question on the motion and upon call of the roll, the following named Councilmembers voted. Aye: Schultz, deBuhr, Kruse, Harding, Ganfield, Sires, Dunn. Nay: None. Motion Carried. The Mayor then declared Resolution #23,033 duly passed and adopted.

54113 - It was moved by Dunn and seconded by Harding that the bills and claims of January 3, 2022 be allowed as presented, and that the Controller/City Treasurer be authorized to issue City checks in the proper amounts and on the proper funds in payment of the same. Upon call of the roll, the following named Councilmembers voted. Aye: Schultz, deBuhr, Kruse, Harding, Ganfield, Sires, Dunn. Nay: None. Motion carried.

54114 - It was moved by Kruse and seconded by Harding to adjourn to Executive Session to discuss Legal Matters per Iowa Code Section 21.5(1)(c) to discuss strategy with counsel in matters that are presently in litigation or where litigation is imminent where its disclosure would be likely to prejudice or disadvantage the position of the governmental body in that litigation. Upon call of the roll, the following named Councilmembers voted. Aye: Schultz, deBuhr, Kruse, Harding, Ganfield, Sires, Dunn. Nay: None. Motion carried.

The City Council adjourned to Executive Session at 8:16 P.M.

Mayor Green reconvened the Council meeting at 9:35 P.M.

54115 - It was moved by Ganfield and seconded by Sires that the meeting be adjourned at 9:36 P.M. Motion carried unanimously.

Jacqueline Danielsen, MMC, City Clerk



DEPARTMENT OF FINANCE & BUSINESS OPERATIONS

CITY OF CEDAR FALLS, IOWA
220 CLAY STREET
CEDAR FALLS, IOWA 50613
319-273-8600
FAX 319-268-5126

INTEROFFICE MEMORANDUM

TO: Mayor Green & City Council Members
FROM: Jennifer Rodenbeck, Director of Finance & Business Operations
DATE: January 11, 2023
SUBJECT: FY23-FY28 Capital Improvements Program

Attached is the FY23-FY28 Capital Improvements Program (CIP) that incorporated the changes from the Finance & Business Operations (FBO) committee on December 19th and adding the *s as approved at the Jan. 3rd City Council meeting to all non-City funding right next to the project line item amount. There will be a presentation at the January 17th FBO committee meeting to discuss possible amendments to the CIP and allow for further council discussion and consideration of the CIP.

If you have questions regarding the CIP, please feel free to contact me.

**FY23 - FY28 CAPITAL IMPROVEMENTS PROGRAM
CITY OF CEDAR FALLS, IOWA**

Item 2.

Presented to City Council/Planning & Zoning Comm:
Approved by the City Council:
Resolution Number:

19-Dec-2022

New FY23

#	PROJECT OR PROGRAM	DEPT/ DIV.	FY23		FY24		FY25		FY26		FY27		FY28		SUBTOTAL		TOTAL FUNDING AMOUNT
			FUNDING		FUNDING		FUNDING		FUNDING		FUNDING		FUNDING		FUNDING		
			SOURCE	AMOUNT	SOURCE	AMOUNT	SOURCE	AMOUNT	SOURCE	AMOUNT	SOURCE	AMOUNT	SOURCE	AMOUNT	SOURCE	AMOUNT	
1	Annual TIF Rebates	AD/ED	TIF-UN	117,390	TIF-UN	76,280	TIF-UN	44,020	TIF-UN	18,810	TIF-UN	9,410			TIF-UN	265,910	8,159,540
			TIF-CH	64,450	TIF-CH	64,450									TIF-CH	128,900	
			TIF-DT	1,409,870	TIF-DT	1,497,170	TIF-DT	1,593,880	TIF-DT	1,619,090	TIF-DT	1,644,720			TIF-DT	7,764,730	
2	Gibson Property Development - Phase I-II	ADM/ED	TIF-STH	150,000	TIF-STH	1,425,000	TIF-STH	1,875,000	TIF-STH	350,000					TIF-STH	3,800,000	3,800,000
3	Gibson Property Development - Phase III-V	ADM/ED											TIF-STH	8,223,000	TIF-STH	8,223,000	8,223,000
4	Industrial Park Expansion (Phase I)	ADM/ED	TIF-UN	9,000,000	TIF-UN	500,000									TIF-UN	9,500,000	9,500,000
5	Industrial Park Land Acquisition	ADM/ED	TIF-UN	3,500,000			TIF-UN	4,000,000			TIF-UN	1,500,000			TIF-UN	9,000,000	9,000,000
6	Northern Industrial Park: Insurance and Maintenance	ADM/ED	TIF-UN	30,000	TIF-UN	30,000	TIF-UN	30,000	TIF-UN	30,000	TIF-UN	30,000	TIF-UN	30,000	TIF-UN	180,000	180,000
7	Bond Fees	FBO/ADM			GO 2024	50,000			GO 2026	50,000			GO 2028	50,000	GO	150,000	150,000
8	Capitalized Interest	FBO/ADM			GO 2024	150,000			GO 2026	150,000			GO 2028	150,000	GO	450,000	450,000
9	Vehicle Replacement Program	FBO/ADM	SCF	440,000	SCF	469,000	SCF	400,000	SCF	400,000	SCF	400,000	SCF	400,000	SCF	2,509,000	6,123,000
			SRF				SRF	35,000	SRF	35,000	SRF	35,000	SRF	35,000	SRF	140,000	
			REF	270,000			REF	200,000	REF	200,000	REF	200,000	REF	200,000	REF	1,070,000	
			VRF	459,000	VRF	345,000	VRF	400,000	VRF	400,000	VRF	400,000	VRF	400,000	VRF	2,404,000	
10	Cable TV Equipment Upgrades	FBO/CTV	CTF	100,000	CTF	100,000	CTF	100,000	CTF	100,000	CTF	100,000	CTF	100,000	CTF	600,000	600,000
11	Video Server	FBO/CTV			CTF	15,000								CTF	15,000	15,000	
12	Master Control Server	FBO/CTV			CTF	55,000								CTF	55,000	55,000	
13	Video Switcher/Replay replacement	FBO/CTV	CTF	40,000										CTF	40,000	40,000	
14	Broadcast Lenses	FBO/CTV	CTF	75,000	CTF	30,000	CTF	75,000						CTF	180,000	180,000	
15	Camera's - Installation, Maintenance & Replacements	FBO/IS	GO 2022	20,000	GO 2022	20,000	GO 2024	70,000	GO 2026	95,000	GO 2028	95,000	GO 2028	70,000	GO	370,000	370,000
16	CIP/Capital Asset Software	FBO/IS	DPR	65,000											DPR	65,000	65,000
17	City Mobile App	FBO/IS	DPR	1,950	DPR	1,950									DPR	3,900	3,900
18	Computer Equipment & Software	FBO/IS	DPR	70,000	DPR	70,000	DPR	70,000	DPR	70,000	DPR	70,000	DPR	70,000	DPR	420,000	420,000
19	Document Imaging	FBO/IS	DPR	20,000	DPR	6,000	DPR	6,000	DPR	6,000	DPR	20,000			DPR	58,000	58,000
20	Door Lock System	FBO/IS	CP	50,400	CP	50,400									CP	100,800	120,000
			DPR	9,600	DPR	9,600									DPR	19,200	
21	Financial System & Human Capital Software	FBO/IS	GO 2022	300,000	GO 2024	400,000									GO	700,000	3,750,000
			DR	500,000											DR	500,000	
			DPR	800,000	DPR	350,000	DPR	350,000	DPR	350,000	DPR	350,000	DPR	350,000	DPR	2,550,000	
22	GIS	FBO/IS	DPR	15,000	DPR	15,000	DPR	15,000	DPR	20,000	DPR	15,000	DPR	15,000	DPR	95,000	95,000
23	Mid-Range Operating System Upgrade	FBO/IS			DPR	4,500									DPR	4,500	4,500
24	Mobile Data Computer Replacement - Police	FBO/IS	DPR	20,000	DPR	15,000	DPR	15,000	DPR	15,000	DPR	15,000	DPR	15,000	DPR	95,000	95,000
25	Network Upgrades	FBO/IS	DPR	75,000	DPR	140,000	DPR	75,000	DPR	110,000	DPR	90,000	DPR	60,000	DPR	550,000	550,000
26	Penetration Security Testing Services	FBO/IS	DPR	80,000	DPR	80,000	DPR	80,000	DPR	80,000	DPR	80,000	DPR	80,000	DPR	480,000	480,000
27	Permitting System	FBO/IS					DPR	320,000	DPR	150,000	DPR	150,000	DPR	150,000	DPR	770,000	770,000
28	Work Order Management Software	FBO/IS	DPR	25,000	DPR	25,000									DPR	50,000	50,000
29	Library Automated Materials Handler	FBO/LIBRARY			GO 2024	86,000									GO	86,000	172,000
					CF	86,000									CF	86,000	
30	Youth Department Service Desk Replacement	FBO/LIBRARY					CF	55,000							CF	55,000	55,000
31	Replacement of Community Center Tables and Chairs	FBO/LIBRARY			CF	50,000									CF	50,000	50,000
32	Parking Lot: City Hall	FBO/PARKING			TIF-DT	130,000									TIF-DT	130,000	130,000
33	Parking Lot: College Hill Parking Restoration	FBO/PARKING	TIF-CH	10,000											TIF-CH	10,000	10,000
34	Parking Lot: Downtown Lot Improvements	FBO/PARKING			TIF-DT	150,000	TIF-DT	150,000							TIF-DT	300,000	300,000
35	Parking Lot: Downtown Parking Ramp Study	FBO/PARKING	TIF-DT	100,000											TIF-DT	100,000	100,000

**FY23 - FY28 CAPITAL IMPROVEMENTS PROGRAM
CITY OF CEDAR FALLS, IOWA**

Item 2.

Presented to City Council/Planning & Zoning Comm:
Approved by the City Council:
Resolution Number:

19-Dec-2022

New FY23

#	PROJECT OR PROGRAM	DEPT/ DIV.	FY23		FY24		FY25		FY26		FY27		FY28		SUBTOTAL		TOTAL FUNDING AMOUNT
			FUNDING		FUNDING		FUNDING		FUNDING		FUNDING		FUNDING		FUNDING		
			SOURCE	AMOUNT	SOURCE	AMOUNT	SOURCE	AMOUNT	SOURCE	AMOUNT	SOURCE	AMOUNT	SOURCE	AMOUNT	SOURCE	AMOUNT	
36	Parking Lot: Downtown Parking Structure	FBO/PARKING			TIF-DT	2,500,000	TIF-DT	1,800,000	TIF-DT	16,100,000					TIF-DT	20,400,000	20,400,000
37	Parking Lot: Gateway Park Parking Lot & Lighting	FBO/PARKING					GO 2026	250,000							GO	250,000	250,000
38	Parking Lot: Pheasant Ridge Pro Shop	FBO/PARKING											GIF	605,000	GIF	605,000	605,000
39	Parking Equipment/Technology Replacement	FBO/PARKING			TIF-CH	20,000								TIF-CH	20,000	300,000	
					TIF-DT	280,000								TIF-DT	280,000		
40	Postage Machine Replacement	FBO/PUB RECORD			GR	15,000								GR	15,000	15,000	
41	Access to Transportation	CD/CDBG			CDBG	22,420								CDBG	22,420	22,420	
42	Consolidated Plan	CD/CDBG			CDBG	10,000								CDBG	10,000	40,000	
					HCV	5,000								HCV	5,000		
					GR	25,000								GR	25,000		
43	Neighborhood Accessibility	CD/CDBG	CDBG	92,870	CDBG	64,000								CDBG	156,870	156,870	
44	Neighborhood Recreational Amenities	CD/CDBG	CDBG	20,000										CDBG	20,000	20,000	
45	Owner Occupied Rehabilitation	CD/CDBG	CDBG	25,000	CDBG	67,000								CDBG	92,000	272,000	
			HOME	90,000	HOME	90,000								HOME	180,000		
46	Renter Occupied Rehabilitation	CD/CDBG	CDBG	75,000	CDBG	33,500								CDBG	108,500	108,500	
47	City Hall Repurpose & Remodel	CD/INSPECT	GFS	2,503,720										GFS	2,503,720	2,503,720	
48	Code Enforcement, Property Clean-up, Condemnation	CD/INSPECT			CDBG	5,000			CDBG	5,000			CDBG	5,000	285,000		
			CP	45,000	CP	45,000	CP	45,000	GP	45,000	CP	45,000	CP	45,000	270,000		
49	Hearst Center Expansion	CD/INSPECT								PRIV	875,000	PRIV	1,495,000	PRIV	2,370,000	8,300,000	
												GO 2028	700,000	GO	700,000		
												CF	750,000	CF	750,000		
								GFS	320,000			GFS	1,130,000	GFS	1,450,000		
										F/S	675,000	F/S	675,000	F/S	1,350,000		
														CIF	180,000		
										BHCG	750,000	BHCG	750,000	BHCG	1,500,000		
50	Land Acquisition - School Administration Site	CD/INSPECT											GFS	210,000	GFS	210,000	
51	Pedestrian way from Andy Ave. to Aldrich Elementary	CD/INSPECT	GO 2024	15,000	GO 2024	15,000								GO	30,000	30,000	
52	Pheasant Ridge Pro Shop and Cart Storage Repairs	CD/INSPECT	GIF	15,000	GIF	50,000			GIF	46,000				GIF	111,000	111,000	
53	UNI Dome Renovation	CD/INSPECT					EDF	1,500,000	EDF	1,500,000				EDF	3,000,000	50,000,000	
					UNI	16,666,670	UNI	15,166,660	UNI	15,166,670				UNI	47,000,000		
54	Bike Network on-street Signage	CD/PLAN	SCF	5,000	SCF	5,000	SCF	5,000	SCF	5,000	SCF	5,000	SCF	5,000	SCF	30,000	30,000
55	Bus Shelters & Related Amenities	CD/PLAN	MET	15,000			MET	15,000			MET	15,000		MET	45,000	45,000	
56	Cedar River Safety and Recreational River Improvements Phase I	CD/PLAN	ER	1,000,000	ER	700,000								ER	1,700,000	6,703,550	
			PRIV	500,000										PRIV	500,000		
			BHCG	1,500,000										BHCG	1,500,000		
			TRC	400,000										TRC	400,000		
					H/M-PK	70,000								H/M-PK	70,000		
					GFS	300,000								GFS	300,000		
			GO 2022	288,550	GO 2022	70,000								GO	358,550		
			GR	150,000										GR	150,000		
			F/S	1,725,000										F/S	1,725,000		
57	Cedar Valley Placemaking	CD/PLAN					F/S	113,240	F/S	113,240				F/S	226,480	592,310	
							GO 2026	125,760	GO 2026	65,750				GO	191,510		
							BHCG	16,000	BHCG	16,000				BHCG	32,000		
							H/M-PK	71,160	H/M-PK	71,160				H/M-PK	142,320		

**FY23 - FY28 CAPITAL IMPROVEMENTS PROGRAM
CITY OF CEDAR FALLS, IOWA**

Item 2.

Presented to City Council/Planning & Zoning Comm:
Approved by the City Council:
Resolution Number:

New FY23

#	PROJECT OR PROGRAM	DEPT/ DIV.	FY23		FY24		FY25		FY26		FY27		FY28		SUBTOTAL		TOTAL FUNDING AMOUNT
			FUNDING		FUNDING		FUNDING		FUNDING		FUNDING		FUNDING		FUNDING		
			SOURCE	AMOUNT	SOURCE	AMOUNT	SOURCE	AMOUNT	SOURCE	AMOUNT	SOURCE	AMOUNT	SOURCE	AMOUNT	SOURCE	AMOUNT	
58	Community-wide Strategic Plan	CD/PLAN			GR	12,500	GR	12,500							GR	25,000	25,000
59	Comprehensive Plan & Zoning Code Updates	CD/PLAN			GR	125,000	GR	150,000	GR	150,000	GR	150,000	GR	150,000	GR	725,000	750,000
					TIF-CH	25,000								TIF-CH	25,000		
60	Conversion of rental homes back to owner-occupied	CD/PLAN	GR	100,000	GR	100,000	GR	100,000	GR	100,000	GR	100,000			GR	500,000	500,000
61	Historic Reconnaissance Survey of Overman Park Neighborhood	CD/PLAN			F/S	11,000								F/S	11,000	13,400	
					GR	2,400								GR	2,400		
62	Parks and Public Lands Master Plan	CD/PLAN					GO 2026	75,000	GO 2026	75,000					GO	150,000	150,000
63	Property/Flood Buyouts	CD/PLAN	F/S	500,000										F/S	500,000	1,080,000	
					CP	300,000	CP	70,000	CP	70,000	CP	70,000	CP	70,000	CP	580,000	
64	Resilience Initiatives	CD/PLAN	GR	25,000			GR	25,000	GR	25,000	GR	25,000	GR	25,000	GR	125,000	125,000
65	Support for Historical Society Enhance Iowa Grant	CD/PLAN			H/M-VT	16,000	H/M-VT	17,000	H/M-VT	17,000				H/M-VT	50,000	50,000	
66	Wayfinding Signage Plan	CD/PLAN							H/M-VT	30,000				H/M-VT	30,000	30,000	
67	Ballfield Fencing Spot Repair	CD/REC	SBPF	3,000	SBPF	3,000	SBPF	3,000	SBPF	3,000	SBPF	3,000	SBPF	3,000	SBPF	18,000	18,000
68	Dugout Covers - Birdsall Park	CD/REC							SBPF	107,000				SBPF	107,000	107,000	
69	Facility Improvements - Rec Center	CD/REC			RCCIP	10,000								RCCIP	10,000	10,000	
70	New HS Pool	CD/REC			RCCIP	1,400,000								RCCIP	1,400,000	21,000,000	
					SCHOOLS	7,600,000	SCHOOLS	500,000						SCHOOLS	8,100,000		
					F/S		F/S	700,000						F/S	700,000		
					BHCG		BHCG	900,000						BHCG	900,000		
					PRIV	3,000,000	PRIV	300,000						PRIV	3,300,000		
					GO 2024	700,000								GO	700,000		
					GFS	3,400,000	GFS	2,500,000						GFS	5,900,000		
71	Orchard Hill Park - Pickleball Expansion	CD/REC			GO 2024	110,000								GO	110,000	400,000	
					PRIV	190,000								PRIV	190,000		
					H/M-PK	100,000								H/M-PK	100,000		
72	Outdoor Fitness Park	CD/REC										NFG	30,000	NFG	30,000	150,000	
												PRIV	120,000	PRIV	120,000		
73	Park Renovations	CD/REC					GO 2026	100,000	GO 2026	50,000	GO 2026	200,000	GO 2028	100,000	GO	450,000	450,000
74	Turf Replacement Robinson Dresser	CD/REC											GO 2028	87,500	GO	87,500	175,000
													RCCIP	87,500	RCCIP	87,500	
75	Weight Equipment	CD/REC	RCRG	300,000										RCRG	300,000	300,000	
76	Falls-Cabanas	CD/REC					RCCIP	15,000						RCCIP	15,000	15,000	
77	Falls-Improve fencing location	CD/REC	RCCIP	9,050										RCCIP	9,050	9,050	
78	Falls-Maintenance	CD/REC	RCCIP	67,000	RCCIP	55,000	RCCIP	65,000	RCCIP	35,000	RCCIP	35,000	RCCIP	35,000	RCCIP	292,000	292,000
79	Falls-Splash Feature	CD/REC	RCCIP	5,000	RCCIP	70,000								RCCIP	75,000	75,000	
80	Hearst Center Master Plan	CD/CULT	ACB	15,000										ACB	15,000	55,000	
			CIF	25,000										CIF	25,000		
			FRIEND	15,000										FRIEND	15,000		
81	Hearst Center Fundraising Feasibility Study	CD/CULT			ACB	15,000								ACB	15,000	40,000	
			FRIEND	10,000	FRIEND	15,000								FRIEND	25,000		
82	RAGBRAI Start Up Funds	CD/V&T					TRC	5,000						TRC	5,000	5,000	

FY23 - FY28 CAPITAL IMPROVEMENTS PROGRAM
CITY OF CEDAR FALLS, IOWA

Item 2.

Presented to City Council/Planning & Zoning Comm:
Approved by the City Council:
Resolution Number:

19-Dec-2022

New FY23

#	PROJECT OR PROGRAM	DEPT/ DIV.	FY23		FY24		FY25		FY26		FY27		FY28		SUBTOTAL		TOTAL FUNDING AMOUNT
			FUNDING		FUNDING		FUNDING		FUNDING		FUNDING		FUNDING		FUNDING		
			SOURCE	AMOUNT	SOURCE	AMOUNT	SOURCE	AMOUNT	SOURCE	AMOUNT	SOURCE	AMOUNT	SOURCE	AMOUNT	SOURCE	AMOUNT	
83	Replace Horse & Rider Sculpture @ Visitor Center	CD/V&T					TRC	950							TRC	950	20,000
							PRIV	9,550							PRIV	9,550	
							ACB	9,500							ACB	9,500	
84	Replacement of Street Banners	CD/V&T			TRC	2,500			TRC	2,500				TRC	2,500	7,500	7,500
85	Tourism Market Study	CD/V&T					TRC	25,000						TRC	25,000	25,000	25,000
86	Visitor Center-Cedar Falls 3D Sign	CD/V&T					TRC	22,000						TRC	22,000	22,000	22,000
87	Visitor Center-Interior Painting & Updates	CD/V&T			TRC	15,000								TRC	15,000	15,000	15,000
88	Visitor Center Retaining Wall and Patio Repair	CD/V&T	TRC	30,000										TRC	30,000	30,000	30,000
89	Bridges/Culverts: Hudson Road Bridge Deck Overlay	PW/ENG					LST	900,000						LST	900,000	900,000	900,000
90	Bridges/Culverts: Inspections/Repairs	PW/ENG	SCF	200,000	SCF	55,000	SCF	200,000	SCF	55,000	SCF	200,000	SCF	55,000	SCF	765,000	765,000
91	Bridges/Culverts: Katowski Drive Box Culvert Replacement	PW/ENG	STW	240,000	STW	240,000								STW	480,000	480,000	480,000
92	Bridges/Culverts: Olive Street Box Culvert Replacement	PW/ENG	TIF-CH	1,400,000	TIF-CH	1,400,000								TIF-CH	2,800,000	2,800,000	2,800,000
93	Bridges/Culverts: Ridgeway Avenue Bridge Replacement	PW/ENG					TIF-STH	185,000						TIF-STH	185,000	665,000	665,000
							F/S	480,000						F/S	480,000		
94	Industrial & City Development: Infrastructure Oversizing	PW/ENG	GO 2022	50,000	GO 2024	50,000	GO 2024	50,000	GO 2026	50,000	GO 2026	50,000	GO 2028	50,000	GO	300,000	660,000
			STW	30,000	STW	30,000	STW	30,000	STW	30,000	STW	30,000	STW	30,000	STW	180,000	
			SRF	30,000	SRF	30,000	SRF	30,000	SRF	30,000	SRF	30,000	SRF	30,000	SRF	180,000	
95	Sanitary Sewer: Gibson Property Extension	PW/ENG					TIF-STH	90,000	TIF-STH	300,000				TIF-STH	390,000	390,000	390,000
96	Sanitary Sewer: Main Street to James Dr. Extension	PW/ENG	SRF	330,000										SRF	330,000	1,020,000	1,020,000
					SA	690,000								SA	690,000		
97	Sanitary Sewer: Northern Industrial Park Realignment	PW/ENG										TIF-UN	550,000	TIF-UN	550,000	550,000	550,000
98	Sanitary Sewer: Pheasant Ridge Water/Sewer Connection	PW/ENG										GIF	110,000	GIF	110,000	110,000	110,000
99	Sanitary Sewer: SW Branch of Dry Run Creek Extension	PW/ENG						SRB-2026	2,310,000					SRB	2,310,000	2,310,000	2,310,000
100	Sidewalks/Trails: Assessment Program	PW/ENG	SA	100,000	SA	100,000	SA	100,000	SA	100,000	SA	100,000	SA	100,000	SA	600,000	600,000
101	Sidewalks/Trails: Autumn Ridge Sidewalk Infill	PW/ENG										GO 2028	65,000	GO	65,000	65,000	65,000
102	Sidewalks/Trails: Grand Avenue Trail Infill (Bronson to Galloway)	PW/ENG										GO 2028	130,000	GO	130,000	130,000	130,000
103	Sidewalks/Trails: Lake Street Trail	PW/ENG	GO 2022	40,000										GO	40,000	290,000	290,000
			F/S	250,000										F/S	250,000		
104	Sidewalks/Trails: Lloyd Lane Sidewalk Infill	PW/ENG								GO 2026	45,000			GO	45,000	45,000	45,000
105	Sidewalks/Trails: McClain Drive Sidewalk Infill	PW/ENG										GO 2028	100,000	GO	100,000	100,000	100,000
106	Sidewalks/Trails: Reconstruction Program	PW/ENG	GO 2022	75,000	GO 2024	100,000	GO 2024	100,000	GO 2026	100,000	GO 2026	100,000	GO 2028	100,000	GO	575,000	575,000
107	Sidewalks/Trails: Trail Oversizing	PW/ENG	GO 2022	20,000	GO 2024	20,000	GO 2024	20,000	GO 2026	20,000	GO 2026	20,000	GO 2028	20,000	GO	120,000	120,000
108	Sidewalks/Trails: Trail Reconstruction	PW/ENG	H/M-TR	50,000	H/M-TR	50,000	H/M-TR	50,000	H/M-TR	50,000	H/M-TR	50,000	H/M-TR	50,000	H/M-TR	300,000	300,000
109	Sidewalks/Trails: Union Road Trail Phase II	PW/ENG	GO 2020	75,000										GO	75,000	90,000	90,000
			F/S	15,000										F/S	15,000		
110	Sidewalks/Trails: W. 20th Street Sidewalk Infill	PW/ENG			GO 2024	50,000								GO	50,000	50,000	50,000
111	Storm Water: Drainage Studies	PW/ENG	F/S	221,000										F/S	221,000	446,000	446,000
			STW	75,000			STW	75,000			STW	75,000		STW	225,000		
112	Storm Water: Huntington Rd. Extension over Green Creek	PW/ENG									STW	250,000		STW	250,000	500,000	500,000
											LST	250,000		LST	250,000		
113	Storm Water: Northern Cedar Falls Storm Sewer Extension	PW/ENG									GO 2028	480,000		GO	480,000	480,000	480,000
114	Storm Water: Slope Repair (Greenwood Cemetery)	PW/ENG	GO 2022	70,000										GO	70,000	620,000	620,000
					STW	275,000	STW	275,000						STW	550,000		

**FY23 - FY28 CAPITAL IMPROVEMENTS PROGRAM
CITY OF CEDAR FALLS, IOWA**

Item 2.

Presented to City Council/Planning & Zoning Comm:
Approved by the City Council:
Resolution Number:

19-Dec-2022

New FY23

#	PROJECT OR PROGRAM	DEPT/ DIV.	FY23		FY24		FY25		FY26		FY27		FY28		SUBTOTAL		TOTAL FUNDING AMOUNT
			FUNDING		FUNDING		FUNDING		FUNDING		FUNDING		FUNDING		FUNDING		
			SOURCE	AMOUNT	SOURCE	AMOUNT	SOURCE	AMOUNT	SOURCE	AMOUNT	SOURCE	AMOUNT	SOURCE	AMOUNT	SOURCE	AMOUNT	
115	Storm Water: Slope Repair (W. Ridgewood Dr.)	PW/ENG	GO 2020	30,000											GO	30,000	330,000
			STW	300,000											STW	300,000	
116	Storm Water: Storm Sewer Extension to North College Street	PW/ENG											GO 2028	10,000	GO	10,000	75,000
													STW	65,000	STW	65,000	
117	Storm Water: University Avenue Bioretention Swales/Cells	PW/ENG	F/S	77,000											F/S	77,000	140,000
			STW	63,000											STW	63,000	
118	Storm Water: W. 18th St. Extension over Dry Run Creek	PW/ENG									STW	250,000			STW	250,000	500,000
											LST	250,000			LST	250,000	
119	Streets: Aldrich Elementary School Connections	PW/ENG	CP	575,000											CP	575,000	6,175,000
					SA	300,000	SA	1,150,000	SA	1,150,000					SA	2,600,000	
							GO 2024	1,375,000	GO 2026	1,375,000					GO	2,750,000	
			SCF	250,000											SCF	250,000	
120	Streets: Alley Reconstruction Program	PW/ENG	STW	85,000	STW	85,000	STW	85,000	STW	85,000	STW	85,000	STW	85,000	STW	85,000	2,450,000
			F/S	60,750											F/S	60,750	
							TIF-DT	80,000	TIF-DT	60,000	TIF-DT	60,000	TIF-DT	60,000	TIF-DT	60,000	
			SCF	364,250	SCF	315,000	SCF	235,000	SCF	235,000	SCF	235,000	SCF	235,000	SCF	1,819,250	
121	Streets: Annual Street Repair Program (Resurfacing & Reconstruction)	PW/ENG	LST	4,000,000	LST	4,000,000	LST	4,000,000	LST	3,500,000	LST	3,940,000	LST	3,940,000	LST	23,380,000	26,900,000
			GO 2022	60,000	GO 2024	60,000	GO 2024	60,000	GO 2026	60,000	GO 2026	60,000	GO 2028	60,000	GO	360,000	
			SRF	250,000	SRF	250,000	SRF	250,000	SRF	250,000	SRF	150,000	SRF	150,000	SRF	1,300,000	
								TIF-UN	500,000						TIF-UN	500,000	
			SCF	240,000	SCF	240,000	SCF	240,000	SCF	240,000	SCF	200,000	SCF	200,000	SCF	1,360,000	
122	Streets: Cedar Heights Drive Reconstruction	PW/ENG	F/S	1,700,000											F/S	1,700,000	2,750,000
			GO 2022	375,000											GO	375,000	
			SCF	75,000											SCF	75,000	
			LST	600,000											LST	600,000	
123	Streets: Center Street Improvements (ER Total Funding = \$800,000)	PW/ENG	STW	300,000											STW	300,000	1,625,000
			ER	775,000											ER	775,000	
			SCF	500,000											SCF	500,000	
			PRIV	50,000											PRIV	50,000	
124	Streets: Cyber Lane Extension	PW/ENG	TIF-STH	55,000											TIF-STH	55,000	55,000
125	Streets: Greenhill Road & South Main Street Intersection	PW/ENG	GO 2022	250,000											GO	250,000	2,575,000
			F/S	500,000											F/S	500,000	
			LST	1,825,000											LST	1,825,000	
126	Streets: Hwy 58 & Greenhill Road Intersection	PW/ENG											F/S	32,000,000	F/S	32,000,000	36,000,000
													TIF-UN	4,000,000	TIF-UN	4,000,000	
127	Streets: Hudson Road & Ridgeway Ave. Traffic Signal	PW/ENG	TIF-STH	210,000											TIF-STH	210,000	580,000
			SCF	200,000											SCF	200,000	
			LST	170,000											LST	170,000	
128	Streets: IANR CFU Spur Grade Crossing Removals	PW/ENG			LST	52,500	LST	125,000	LST	90,000					LST	267,500	4,700,000
					F/S	355,000	F/S	1,125,000	F/S	810,000					F/S	2,290,000	
					RR	177,500	RR	562,500	RR	465,000					RR	1,205,000	
					TIF-DT	62,500	TIF-DT	375,000	TIF-DT	375,000					TIF-DT	812,500	
					CP	62,500	CP	62,500							CP	125,000	

**FY23 - FY28 CAPITAL IMPROVEMENTS PROGRAM
CITY OF CEDAR FALLS, IOWA**

Item 2.

Presented to City Council/Planning & Zoning Comm:
Approved by the City Council:
Resolution Number:

19-Dec-2022

New FY23

#	PROJECT OR PROGRAM	DEPT/ DIV.	FY23		FY24		FY25		FY26		FY27		FY28		SUBTOTAL		TOTAL FUNDING AMOUNT	
			FUNDING		FUNDING		FUNDING		FUNDING		FUNDING		FUNDING		FUNDING			
			SOURCE	AMOUNT	SOURCE	AMOUNT	SOURCE	AMOUNT	SOURCE	AMOUNT	SOURCE	AMOUNT	SOURCE	AMOUNT	SOURCE	AMOUNT		
129	Streets: Main Street Reconstruction	PW/ENG	F/S	1,500,000	F/S	1,400,000									F/S	2,900,000	31,052,000	
			SCF	687,000	SCF	687,000	SCF	4,478,000							SCF	5,852,000		
			ARPA	900,000	ARPA	1,550,000	ARPA	200,000							ARPA	2,650,000		
			STW	500,000	STW	500,000	STW	200,000							STW	1,200,000		
			CFU	1,450,000	CFU	1,450,000	CFU	200,000							CFU	3,100,000		
			LST	5,000,000	LST	5,800,000	LST	1,900,000							LST	12,700,000		
			TIF-DT	1,600,000	TIF-DT	500,000									TIF-DT	2,100,000		
			GO 2022	50,000			GO 2026	500,000							GO	550,000		
130	Streets: Prairie Parkway Roundabout Landscaping Improvements	PW/ENG	TIF-PP	450,000										TIF-PP	450,000	490,000		
			PRIV	40,000										PRIV	40,000			
131	Streets: Prairie Parkway & Viking Road Intersection Improvements	PW/ENG			TIF-PP	300,000	TIF-PP	3,200,000						TIF-PP	3,500,000	3,500,000		
132	Streets: Ridgeway Avenue Reconstruction	PW/ENG	TIF-STH	1,300,000	TIF-STH	1,300,000								TIF-STH	2,600,000	2,600,000		
133	Streets: Seal Coat Program	PW/ENG	LST	100,000	LST	100,000	LST	100,000	LST	100,000	LST	100,000	LST	100,000	LST	600,000	1,500,000	
			SCF	150,000	SCF	150,000	SCF	150,000	SCF	150,000	SCF	150,000	SCF	150,000	SCF	900,000		
134	Streets: Traffic Planning	PW/ENG			SCF	150,000	SCF	75,000	SCF	75,000	SCF	75,000	SCF	75,000	SCF	450,000	450,000	
135	Streets: Union Road Culvert Replacement	PW/ENG					GO 2026	10,000							GO	10,000	660,000	
							STW	60,000	STW	340,000					STW	400,000		
							SRF	15,000	SRF	235,000					SRF	250,000		
136	Streets: Viking Road Reconstruction & Sidewalk Infill	PW/ENG	TIF-UN	6,600,000										TIF-UN	6,600,000	6,965,000		
			CFU	365,000										CFU	365,000			
137	Streets: W. 12th Street Extension	PW/ENG							SCF	570,000					SCF	570,000	1,130,000	
															PRIV	500,000		
																CFU		60,000
138	Streets: W. 22nd Street Reconstruction	PW/ENG			LST	385,000									LST	385,000	1,115,000	
			GO 2022	80,000											GO	80,000		
							SCF	250,000								SCF		250,000
							TIF-CH	400,000								TIF-CH		400,000
139	Streets: W. 23rd Street Reconstruction	PW/ENG			GO 2024	100,000									GO	100,000	1,100,000	
							CFU	100,000								CFU		100,000
							LST	650,000								LST		650,000
							UNI	250,000								UNI		250,000
140	Streets: West 27th Street Improvements	PW/ENG	SCF	740,000	SCF	750,000									SCF	1,490,000	7,450,000	
			GO 2022	110,000												GO		110,000
			SCHOOLS	1,875,000	SCHOOLS	1,875,000										SCHOOLS		3,750,000
			LST	1,000,000	LST	1,100,000										LST		2,100,000
141	Streetscape: Downtown Streetscape & Reconstruction Phase II	PW/ENG	TIF-DT	150,000										TIF-DT	150,000	150,000		
142	Cemetery Columbariums	PW/CEM			GR	70,000	GR	70,000	GR	70,000				GR	210,000	210,000		
143	Golf Course Maintenance	PW/GOLF	GIF	5,000	GIF	5,000	GIF	10,000	GIF	5,000	GIF	10,000	GIF	5,000	GIF	40,000	40,000	
144	Pheasant Ridge Cart Path Renovations	PW/GOLF	GIF	65,000				GIF	40,000			GIF	40,000	GIF	145,000	145,000		
145	Bess Streeter Park Playground Equipment Upgrade	PW/PARK	H/M-PK	63,000										H/M-PK	63,000	63,000		
146	Big Woods Lake Cabin	PW/PARK			BHC	62,500									BHC	62,500	125,000	
							BWMR	62,500							BWMR	62,500		
147	Cedar River Dam Maintenance	PW/PARK	CP	75,000										CP	75,000	75,000		
148	Gold Star Family Memorial Monument	PW/PARK			PRIV	65,000	PRIV	40,000						PRIV	105,000	105,000		

**FY23 - FY28 CAPITAL IMPROVEMENTS PROGRAM
CITY OF CEDAR FALLS, IOWA**

Item 2.

Presented to City Council/Planning & Zoning Comm:
Approved by the City Council:
Resolution Number:

19-Dec-2022

New FY23

#	PROJECT OR PROGRAM	DEPT/ DIV.	FY23		FY24		FY25		FY26		FY27		FY28		SUBTOTAL		TOTAL FUNDING AMOUNT
			FUNDING		FUNDING		FUNDING		FUNDING		FUNDING		FUNDING		FUNDING		
			SOURCE	AMOUNT	SOURCE	AMOUNT	SOURCE	AMOUNT	SOURCE	AMOUNT	SOURCE	AMOUNT	SOURCE	AMOUNT	SOURCE	AMOUNT	
149	Mini Plaza on 1st St. Historical Area - Rotary Club	PW/PARK			PRIV	75,000									PRIV	75,000	75,000
150	New Park Identification Signage	PW/PARK	H/M-PK	25,000											H/M-PK	25,000	25,000
151	Park Improvements	PW/PARK	H/M-PK	25,000	H/M-PK	25,000	H/M-PK	25,000	H/M-PK	25,000	H/M-PK	25,000	H/M-PK	25,000	H/M-PK	150,000	150,000
152	Pickle Ball Court Maintenance	PW/PARK	GR	35,000	GR	5,000	GR	5,000	GR	5,000	GR	5,000	GR	40,000	GR	95,000	95,000
153	Place to Play Park - Future Maintenance	PW/PARK	PRIV	6,000	PRIV	6,000	PRIV	6,000	PRIV	6,000	PRIV	6,000	PRIV	6,000	PRIV	36,000	36,000
154	Place to Play Park Modifications	PW/PARK	PRIV	50,000											PRIV	50,000	50,000
155	Private Property Hazardous Tree Removal	PW/PARK	SA	2,000,000	SA	2,000,000									SA	4,000,000	4,000,000
156	Roundabout Landscape Improvements	PW/PARK	GR	5,000	GR	10,000	GR	10,000	GR	10,000	GR	10,000	GR	10,000	GR	55,000	55,000
157	Serley Park Renovation	PW/PARK	H/M-PK	25,000			H/M-PK	56,000							H/M-PK	81,000	400,000
								GO 2026	239,000						GO	239,000	
							PRIV	9,000	PRIV	36,000					PRIV	45,000	
							CF	10,000	CF	25,000					CF	35,000	
158	Skate Park Relocation	PW/PARK			PRIV	300,000									PRIV	300,000	300,000
159	Street Tree Replacement	PW/PARK	H/M-PK	8,000	H/M-PK	8,000	H/M-PK	8,000	H/M-PK	10,000	H/M-PK	10,000	H/M-PK	10,000	H/M-PK	54,000	54,000
160	Trail Maintenance	PW/PARK	H/M-TR	50,000	H/M-TR	50,000	H/M-TR	50,000	H/M-TR	50,000	H/M-TR	50,000	H/M-TR	50,000	H/M-TR	300,000	300,000
161	Veterans Park Restrooms	PW/PARK							PRIV	50,000					PRIV	50,000	50,000
162	Cedar Falls Landscape Improvements	PW/LANDSCAPE	CP	25,000	CP	25,000	CP	25,000	CP	25,000	CP	25,000	CP	25,000	CP	150,000	150,000
163	Beach House Dehumidification System	PW/BLDG			BH	15,000									BH	15,000	15,000
164	Building Exterior Weatherproofing - Public Buildings	PW/BLDG	GR	60,000			GR	60,000			GR	60,000			GR	180,000	180,000
165	Community Center Flooring and Furniture	PW/BLDG	CF	6,000											CF	6,000	63,000
			GR	57,000											GR	57,000	
166	LED Lighting Upgrade - Aquatic Center	PW/BLDG	GR	25,000											GR	25,000	25,000
167	LED Lighting Upgrade - Library	PW/BLDG			GR	35,000	GR	30,000							GR	65,000	65,000
168	Library Atrium Window Replacement	PW/BLDG			CF	15,000									CF	15,000	25,000
					GR	10,000									GR	10,000	
169	Library Drive-Through Book Returns	PW/BLDG	CF	3,500											CF	3,500	7,000
			GR	3,500											GR	3,500	
170	Rec Center Heat Pumps	PW/BLDG	RCCIP	20,000	RCCIP	25,000	RCCIP	25,000	RCCIP	25,000					RCCIP	95,000	95,000
171	Expanded Poly Styrene (Styrofoam) Densifier	PW/REF			REF	95,000									REF	95,000	95,000
172	Orchard Hill Recycling Drop Site Improvements	PW/REF			REF	25,000									REF	25,000	25,000
173	Refuse and Yard Waste Cart Tracking	PW/REF	REF	25,000	REF	25,000									REF	50,000	50,000
174	Security Cameras at Recycling Sites	PW/REF			REF	50,000	REF	50,000							REF	100,000	100,000
175	SW Solid Waste Transfer Station	PW/REF											REF	1,000,000	REF	1,000,000	1,000,000
176	Material Storage Bunkers	PW/STR								SCF	75,000				SCF	75,000	75,000
177	Streetscape: College Hill Maintenance & Improvements	PW/STR	TIF-CH	5,000	TIF-CH	5,000	TIF-CH	5,000	TIF-CH	5,000	TIF-CH	300,000	TIF-CH	5,000	TIF-CH	325,000	325,000
178	Streetscape: Downtown Maintenance & Improvements	PW/STR	TIF-DT	10,000	TIF-DT	10,000	TIF-DT	10,000	TIF-DT	10,000	TIF-DT	10,000	TIF-DT	10,000	TIF-DT	60,000	60,000
179	Storm Water: Erosion Repair Project	PW/STR	STW	25,000	STW	25,000	STW	25,000	STW	25,000	STW	25,000	STW	25,000	STW	150,000	150,000
180	Signalized Intersection Upgrade	PW/TO	SCF	200,000	SCF	200,000	SCF	200,000	SCF	200,000	SCF	200,000	SCF	200,000	SCF	1,200,000	1,200,000
181	Siren Replacement	PW/TO	GR	60,000	GR	5,000	GR	5,000	GR	5,000	GR	5,000	GR	5,000	GR	85,000	85,000
182	Bulk Fluids Room Expansion	PW/VEH MAINT			VRF	100,000									VRF	100,000	100,000
183	Electric Shore Station for Patrol Vehicles	PW/VEH MAINT					VRF	50,000							VRF	50,000	50,000
184	P511 Replacement Aerial Truck	PW/VEH MAINT										GO 2028	1,800,000	GO	1,800,000	1,800,000	1,800,000

**FY23 - FY28 CAPITAL IMPROVEMENTS PROGRAM
CITY OF CEDAR FALLS, IOWA**

Item 2.

Presented to City Council/Planning & Zoning Comm:
Approved by the City Council:
Resolution Number:

19-Dec-2022

New FY23

#	PROJECT OR PROGRAM	DEPT/ DIV.	FY23		FY24		FY25		FY26		FY27		FY28		SUBTOTAL		TOTAL FUNDING AMOUNT
			FUNDING		FUNDING		FUNDING		FUNDING		FUNDING		FUNDING		FUNDING		
			SOURCE	AMOUNT	SOURCE	AMOUNT	SOURCE	AMOUNT	SOURCE	AMOUNT	SOURCE	AMOUNT	SOURCE	AMOUNT	SOURCE	AMOUNT	
185	Vehicle Locators	PW/VEH MAINT					VRF	15,000	VRF	10,000					VRF	25,000	25,000
186	Building Maintenance	PW/WTR									SRF	30,000			SRF	30,000	30,000
187	Hudson Road Sanitary Line Replacement	PW/WTR											SRF	50,000	SRF	50,000	50,000
188	Lift Station Pump Rebuild or Replacement	PW/WTR	SRF	75,000	SRF	135,000	SRF	75,000	SRF	75,000	SRF	75,000	SRF	75,000	SRF	510,000	510,000
189	Nutrient Reduction Improvements	PW/WTR			SRB-2024	13,550,000	SRB-2024	30,000,000	SRB-2026	31,000,000	SRB-2026	34,000,000			SRB	108,550,000	112,400,000
					ARPA	3,850,000	ARPA							ARPA	3,850,000		
190	Oak Park Sewer Replacement Project	PW/WTR	SRB-2018	900,000											SRB	900,000	900,000
191	Cross Connection Removal Reimbursement	PW/WTR	SRF	150,000	SRF	150,000	SRF	150,000	SRF	50,000	SRF	50,000	SRF	50,000	SRF	600,000	600,000
192	Polymer Pumps	PW/WTR	SRF	75,000											SRF	75,000	75,000
193	Sanitary Sewer Infiltration & Inflow Reduction Project	PW/WTR	SRF	50,000	SRF	50,000	SRF	50,000	SRF	50,000	SRF	50,000	SRF	50,000	SRF	300,000	300,000
194	Sanitary Sewer Spot Repairs/Emergency	PW/WTR	SRF	30,000	SRF	30,000	SRF	30,000	SRF	30,000	SRF	30,000	SRF	30,000	SRF	180,000	180,000
195	Sartori Trust Farm Improvements	PW/WTR									HT	20,000			HT	20,000	20,000
196	Sewer Collection System Expansion Study	PW/WTR					SRF	250,000							SRF	250,000	250,000
197	Sipline Existing Sanitary Sewers	PW/WTR	SRF	250,000	SRF	250,000	SRF	250,000	SRF	250,000	SRF	250,000	SRF	250,000	SRF	1,500,000	1,500,000
198	UV Disinfection Bulb Replacement	PW/WTR	SRF	60,000									SRF	60,000	SRF	120,000	120,000
199	AED	PSS/FIRE					GR	15,000							GR	15,000	15,000
200	Bunker Gear, Replacement of Pass Devices and Volunteer Equipment	PSS/FIRE	GO 2022	45,000	GO 2024	63,000	GO 2024	45,000	GO 2026	45,000	GO 2026	45,000	GO 2028	45,000	GO	288,000	288,000
201	Fire Hose	PSS/FIRE	GR	21,000			GR	6,000	GR	12,000	GR	6,000	GR	12,000	GR	57,000	57,000
202	Hazardous Material Upgrade	PSS/FIRE					GR	8,000							GR	8,000	8,000
203	Replacement of Thermal Imaging Units	PSS/FIRE			GR	18,760	GR	18,760							GR	37,520	37,520
204	SCBA Replacement	PSS/FIRE			GO 2024	98,010									GO	98,010	392,040
					FF	294,030									FF	294,030	
205	Technical Rescue Equipment and SCBA	PSS/FIRE	GO 2024	5,000	GO 2024	10,000	GO 2024	7,000	GO 2026	7,000	GO 2026	10,000	GO 2028	7,000	GO	46,000	46,000
206	Ballistic Vests Replacements	PSS/POLICE	PF	4,880	PF	7,000	PF	7,000							PF	18,880	79,750
			F/S	4,870	F/S	7,000	F/S	7,000	F/S	14,000	F/S	14,000	F/S	14,000	F/S	60,870	
207	Equipment Reserve	PSS/POLICE	GR	9,000	GR	11,000	GR	11,000	GR	11,000	GR	11,000	GR	11,000	GR	64,000	64,000
208	Forensic Cellphone & Tablet Equipment	PSS/POLICE			GR	5,000			GR	7,500			GR	10,000	GR	22,500	22,500
209	In Car Camera/Body Cameras	PSS/POLICE			GO 2024	240,000									GO	240,000	240,000
210	Lab and Investigative Equipment	PSS/POLICE	GR	10,000			GR	12,000			GR	12,000			GR	34,000	34,000
211	Radar	PSS/POLICE	GR	9,000	GR	12,000	GR	12,000	GR	12,000	GR	8,000	GR	8,000	GR	61,000	61,000
212	Firearms, TASERS, Less-Lethal Systems	PSS/POLICE	GR	18,000	GR	10,000	GR	20,000	GR	20,000	GR	15,000	GR	15,000	GR	98,000	98,000
FY23-28 CIP TOTAL				\$73,923,600		\$94,829,140		\$90,881,980		\$85,236,720		\$50,869,130		\$63,901,500		\$459,642,070	\$459,642,070

	FY23	FY24	FY25	FY26	FY27	FY28	TOTAL	
ACB --- Art Culture Board	15,000	15,000	9,500	0	0	0	39,500	--- ACB
ARPA --- American Rescue Plan Act	900,000	5,400,000	200,000	0	0	0	6,500,000	--- ARPA *
BH --- Beach House Escrow	0	15,000	0	0	0	0	15,000	--- BH
BHC --- Black Hawk County	0	62,500	0	0	0	0	62,500	--- BHC *
BHCG --- Black Hawk County Gaming Grant	1,500,000	0	916,000	16,000	750,000	750,000	3,932,000	--- BHCG *
BWMR --- Big Woods Maintenance Revenue	0	62,500	0	0	0	0	62,500	--- BWMR
CDBG --- Community Development Block Grant	212,870	201,920	0	5,000	0	5,000	424,790	--- CDBG *
CF --- Community Foundation	9,500	151,000	65,000	25,000	0	750,000	1,000,500	--- CF *
CFU --- Cedar Falls Utility	1,815,000	1,450,000	300,000	60,000	0	0	3,625,000	--- CFU *
CIF --- Cultural Improvement Fund	25,000	0	0	180,000	0	0	205,000	--- CIF
CMS --- Community Main Street	0	0	0	0	0	0	0	--- CMS *
CP --- Capital Projects	770,400	482,900	202,500	140,000	140,000	140,000	1,875,800	--- CP
CTF --- Cable Television Fund	215,000	200,000	175,000	100,000	100,000	100,000	890,000	--- CTF
DPR --- Data Processing Receipts	1,181,550	717,050	931,000	801,000	790,000	740,000	5,160,600	--- DPR
DR --- Data Processing Cash Reserves	500,000	0	0	0	0	0	500,000	--- DR
EDF --- Economic Development Fund	0	0	1,500,000	1,500,000	0	0	3,000,000	--- EDF
ER --- Emergency Reserve	1,775,000	700,000	0	0	0	0	2,475,000	--- ER
FF --- Assist to FF Grant	0	294,030	0	0	0	0	294,030	--- FF *
FRIEND --- Friends of the Public Library & Hearst	25,000	15,000	0	0	0	0	40,000	--- FRIEND *
F/S --- Federal or State Funding	6,553,620	1,773,000	2,425,240	937,240	689,000	32,689,000	45,067,100	--- F/S *
GFS --- General Fund Savings	2,503,720	3,700,000	2,500,000	320,000	0	1,340,000	10,363,720	--- GFS
GIF --- Golf Improvement Fund	85,000	55,000	50,000	51,000	50,000	720,000	1,011,000	--- GIF
GO 2020 --- General Obligation Bond	105,000	0	0	0	0	0	105,000	--- GO 2020
GO 2022 --- General Obligation Bond	1,833,550	90,000	0	0	0	0	1,923,550	--- GO 2022
GO 2024 --- General Obligation Bond	20,000	2,302,010	1,727,000	0	0	0	4,049,010	--- GO 2024
GO 2026 --- General Obligation Bond	0	0	1,060,760	2,381,750	530,000	0	3,972,510	--- GO 2026
GO 2028 --- General Obligation Bond	0	0	0	0	575,000	3,544,500	4,119,500	--- GO 2028
GR --- General Revenue	587,500	471,660	570,260	427,500	407,000	286,000	2,749,920	--- GR
HCV --- Section 8	0	5,000	0	0	0	0	5,000	--- HCV *
H/M --- Hotel/Motel Tax Receipts	0	0	0	0	0	0	0	--- H/M-PK
H/M-PK --- Hotel/Motel Tax Receipts-Parks	146,000	203,000	160,160	106,160	35,000	35,000	685,320	--- H/M-PK
H/M-TR --- Hotel/Motel Tax Receipts-Trails	100,000	100,000	100,000	100,000	100,000	100,000	600,000	--- H/M-TR
H/M-VT --- Hotel/Motel Tax Receipts-Visitor & Tourism	0	16,000	17,000	47,000	0	0	80,000	--- H/M-VT
HOME --- HOME Investment Partnerships Program	90,000	90,000	0	0	0	0	180,000	--- HOME *
HT --- Health Trust	0	0	0	0	20,000	0	20,000	--- HT
LST --- Local Sales Tax (LST)	12,695,000	11,437,500	7,675,000	3,690,000	4,540,000	4,040,000	44,077,500	--- LST
MET --- MET Transit	15,000	0	15,000	0	15,000	0	45,000	--- MET *
NFG --- National Fitness Grant	0	0	0	0	0	30,000	30,000	--- NFG *
PF --- Police Forfeiture	4,880	7,000	7,000	0	0	0	18,880	--- PF
PMF --- Parking Meter Fund	0	0	0	0	0	0	0	--- PMF
PRIV --- Private Contribution	646,000	3,636,000	364,550	592,000	881,000	1,621,000	7,740,550	--- PRIV *
RCCIP --- Recreation Center Capital	101,050	1,560,000	105,000	60,000	35,000	122,500	1,983,550	--- RCCIP
RCRG --- Rec Relief Grant	300,000	0	0	0	0	0	300,000	--- RCRG
REF --- Refuse Fund	295,000	195,000	250,000	200,000	200,000	1,200,000	2,340,000	--- REF
RR --- Railroad CN	0	177,500	562,500	465,000	0	0	1,205,000	--- RR *
SA --- Special Assessment	2,100,000	3,090,000	1,250,000	1,250,000	100,000	100,000	7,890,000	--- SA *
SBPF --- Softball Player Fund	3,000	3,000	3,000	110,000	3,000	3,000	125,000	--- SBPF
SCF --- Street Construction Fund	4,051,250	3,271,000	5,983,000	1,930,000	1,540,000	1,320,000	18,095,250	--- SCF
SCHOOLS --- School	1,875,000	9,475,000	500,000	0	0	0	11,850,000	--- SCHOOLS *
SRB-2018 --- Sewer Revenue Bond - 2018	900,000	0	0	0	0	0	900,000	--- SRB-2018
SRB-2024 --- Sewer Revenue Bond - 2024	0	13,550,000	30,000,000	0	0	0	43,550,000	--- SRB-2024
SRB-2026 --- Sewer Revenue Bond - 2026	0	0	0	33,310,000	34,000,000	0	67,310,000	--- SRB-2026
SRF --- Sanitary Sewer Rental Fund	1,300,000	895,000	1,135,000	1,005,000	700,000	780,000	5,815,000	--- SRF
STW --- Storm Water Fund	1,618,000	1,155,000	750,000	480,000	715,000	205,000	4,923,000	--- STW
TIF-CH --- Tax Increment Financing - College Hill	1,479,450	1,914,450	5,000	5,000	300,000	5,000	3,708,900	--- TIF-CH
TIF-DT --- Tax Increment Financing - Downtown	3,269,870	5,129,670	4,008,880	18,164,090	1,714,720	70,000	32,357,230	--- TIF-DT
TIF-UN --- Tax Increment Financing - Unified Industrial Park	19,247,390	606,280	4,074,020	548,810	1,539,410	4,580,000	30,595,910	--- TIF-UN
TIF-PP --- Tax Increment Financing - Pinnacle Prairie	450,000	300,000	3,200,000	0	0	0	3,950,000	--- TIF-PP
TIF-STH --- Tax Increment Financing - South Cedar Falls	1,715,000	2,725,000	2,150,000	650,000	0	8,223,000	15,463,000	--- TIF-STH
TRC --- Tourism Cash Reserves	430,000	17,500	52,950	2,500	0	2,500	505,450	--- TRC
UNI --- University of Northern Iowa	0	16,666,670	15,416,660	15,166,670	0	0	47,250,000	--- UNI *
VRF --- Vehicle Rental Fees	459,000	445,000	465,000	410,000	400,000	400,000	2,579,000	--- VRF
TOTALS:	\$73,923,600	\$94,829,140	\$90,881,980	\$85,236,720	\$50,889,130	\$63,901,500	\$459,642,070	TOTAL
GO-2020 Amounts	105,000	0	0	0	0	0	105,000	GO-2020 Bond
GO-2022 Amounts	1,833,550	90,000	0	0	0	0	1,923,550	GO-2022 Bond
GO-2024 Amounts	20,000	2,302,010	1,727,000	0	0	0	4,049,010	GO-2024 Bond
GO-2026 Amounts	0	0	1,060,760	2,381,750	530,000	0	3,972,510	GO-2026 Bond
GO-2028 Amounts	0	0	0	0	575,000	3,544,500	4,119,500	GO-2028 Bond
SRB-2018	900,000	0	0	0	0	0	900,000	SRB-2018
SRB-2024	0	13,550,000	30,000,000	0	0	0	43,550,000	SRB-2024
SRB-2026	0	0	0	33,310,000	34,000,000	0	67,310,000	SRB-2026
Capital Projects:	770,400	482,900	202,500	140,000	140,000	140,000	1,875,800	Capital Projects
Bonds/CapProj:	\$3,628,950	\$16,424,910	\$32,990,260	\$35,831,750	\$35,245,000	\$3,684,500	\$127,805,370	Bond/Capital Projects Total

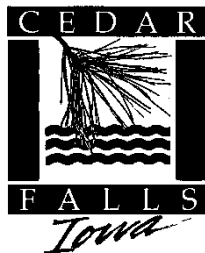

DEPARTMENT OF FINANCE & BUSINESS OPERATIONS

CITY OF CEDAR FALLS, IOWA
220 CLAY STREET
CEDAR FALLS, IOWA 50613
319-273-8600
FAX 319-268-5126

INTEROFFICE MEMORANDUM

TO: Mayor Green and City Council Members
FROM: Jennifer Rodenbeck, Director of Finance & Business Operations
DATE: January 10, 2023
SUBJECT: Annual Reimbursement Resolution

Please find attached a copy of the IRS mandated reimbursement resolution. Each year the City submits a list of projects prior to the sale of General Obligation bonds and Revenue bonds that allows the City to be eligible to reimburse ourselves from the bond funds for previously incurred expenses relating to the projects listed.

The attachment referred to in the resolution will be the FY23-FY28 Capital Improvements Program (CIP) that is also being presented to Council for approval. After formal adoption, a copy of the final CIP will be attached to the resolution and filed in the City's official records.

If you have any questions, please feel free to contact me.

RESOLUTION NO. _____

RESOLUTION DECLARING AN OFFICIAL INTENT UNDER TREASURY REGULATION 1.150-2 TO ISSUE DEBT TO REIMBURSE THE CITY FOR CERTAIN ORIGINAL EXPENDITURES PAID IN CONNECTION WITH SPECIFIED PROJECTS

WHEREAS, the City anticipates making cash expenditures for one or more capital improvements projects, generally described on Attachment A (each of which shall hereinafter be referred to as a "Project"), and

WHEREAS, the City reasonably expects to issue debt to reimburse the costs of a Project, and

WHEREAS, the Council believes it is consistent with the City's budgetary and financial circumstances to issue this declaration of official intent.

NOW THEREFORE, be it resolved by the City Council of the City of Cedar Falls, Iowa:

Section 1. That this Resolution be and does hereby serve as a declaration of official intent under Treasury Regulation 1.150-2.

Section 2. That it is reasonably expected that capital expenditures will be made in respect of the foregoing Projects, from time to time and in such amounts as this Council determines to be necessary or desirable under the circumstances then and there existing.

Section 3. That the City reasonably expects to reimburse all or a portion of the foregoing expenditures with the proceeds of bonds, notes or other indebtedness to be issued or incurred by the City in the future.

Section 4. That the total estimated costs of the projects, the maximum principal amount of bonds, notes or other indebtedness to be issued for the foregoing Projects and the estimated dates of completion of the Projects are reasonably expected to be as follows:

See Attachment A:

- All Projects with the identifications code of G.O. 2020, 2022, 2024, 2026, and 2028; SRF, STW, SRB-2018, SRB-2024, and SRB-2026.
- All Projects with the identifications code of TIF-UN, TIF-DT, TIF-CH, TIF-PP, and TIF-STH.
- All Projects with CP, LST, SCF, ER, and GFS.

If such grants are not received, it is intended that the costs to be financed will be increased accordingly.

Section 5. That the City reasonably expects to reimburse the above-mentioned Project costs no later than the later of eighteen months after the capital expenditures are paid or eighteen months after the property is placed in service.

Section 6. That this Resolution be maintained by the City Clerk in an Official Intent File maintained in the office of the City Clerk and available at all times for public inspection, subject to such revisions as may be necessary.

ADOPTED this 17th day of January 2023.

Robert M. Green, Mayor

ATTEST:

Jacque Danielsen, MMC, City Clerk



DEPARTMENT OF COMMUNITY DEVELOPMENT

City of Cedar Falls
 220 Clay Street
 Cedar Falls, Iowa 50613
 Phone: 319-273-8600
 Fax: 319-273-8610
 www.cedarfalls.com

MEMORANDUM

Planning & Community Services Division

TO: Honorable Mayor Robert M. Green and City Council
FROM: Chris Sevy, Planner I
DATE: January 17, 2023
SUBJECT: Zoning Agreement – Midway Business Park

REQUEST: New Zoning Agreement - Midway Business Park

PETITIONER: Lucas Moore, Oak District LLC

LOCATION: Lots 5 & 6 Midway Business Park: Greenhill Circle

PROPOSAL

The applicant submitted a request to amend the zoning restriction placed on Lots 5 and 6 of the Midway Business Park subdivision. This restriction only allows for the construction of professional service office buildings and the applicant wishes to establish a nursing home/senior assisted living facility on said lots.

BACKGROUND

In the process of preparing an amendment to the zoning agreement it was discovered that there was an error in the legal description included in the original zoning agreement from 1994 so it did not accurately describe the same properties that were rezoned to R-4 at the time. Since this error nullifies that rezoning, the agreement, and any subsequent amendments, it is best to rescind the original agreement and draft a new one that includes the conditions that remain relevant today, specifically the use restrictions in the Midway Business Park. It is also necessary to properly rezone to R-4 as the original resolution to rezone used the same legal description as the agreement.

The other two conditions of the original 1994 agreement have already been accomplished. Namely, Lovejoy Drive ends in a cul-de-sac, and four single family homes have been constructed on the four lots at the end of Lovejoy. This effectively separates the residential neighborhood from the Midway Business Park, so no commercial traffic can flow through the neighborhood (see aerial image below). For reference, the minutes from the previous meeting are noted below.

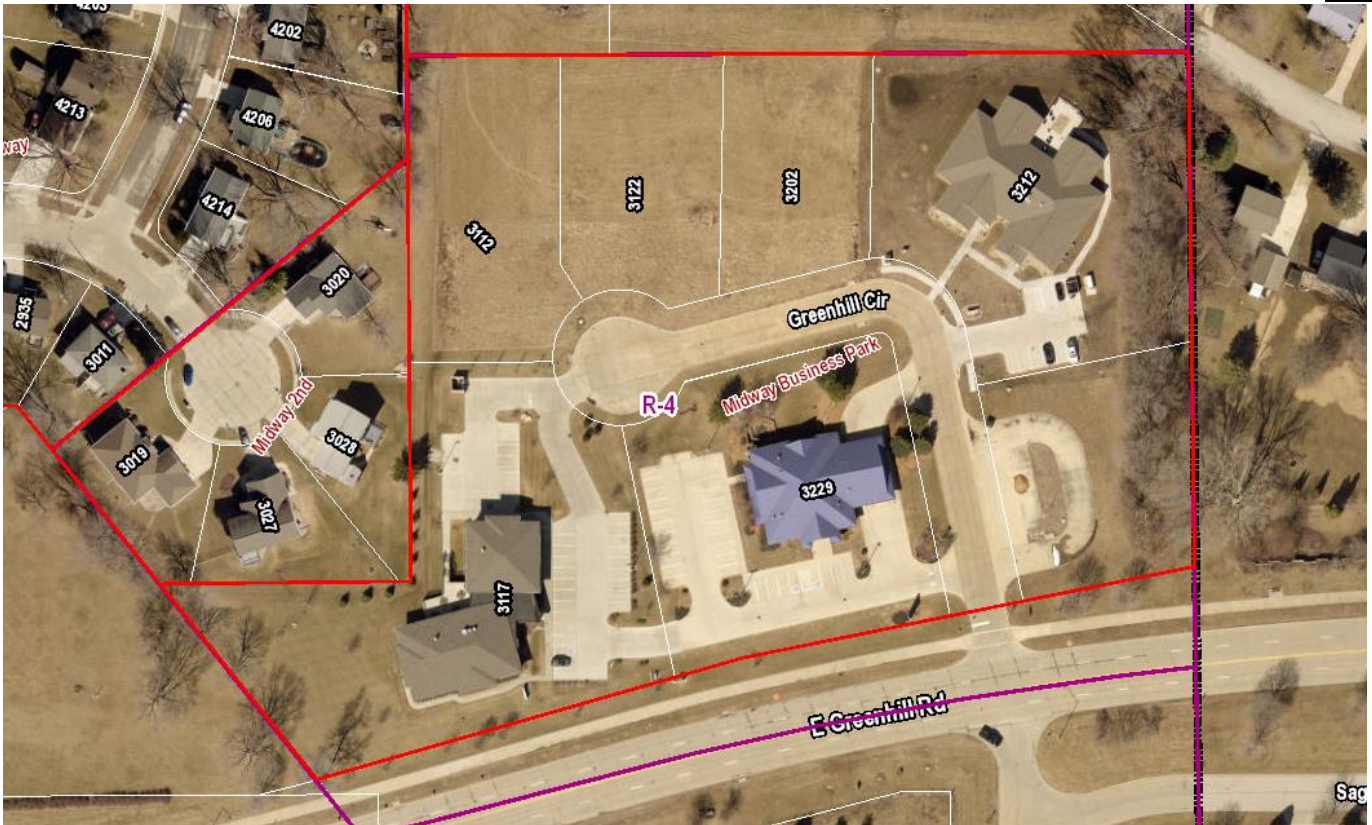

Aside from the issue of the legal description of the land this would apply to, no material facts regarding the request and staff's analysis have changed. It should be noted that an amendment to the 1994 agreement was approved in 2018 which provided for a nursing home/senior assisted living use on lots 7 and 8. With the success of the initial facility, Oak District, the applicant would like to take the necessary steps with a new zoning agreement to allow a second similar assisted living facility on Lots 5 & 6. If this request is approved, only two lots within the Midway Business Park Subdivision will remain undeveloped.

One important issue is that there are four single-family homes at the end of Lovejoy Drive (cul-de-sac abutting the business park) that were zoned R-4 and were included in the 1994 agreement to be restricted to single-family use. Since the conditions of the original 1994 agreement have already been accomplished and the legal description did not entirely encompass those lots, the use restrictions may not be enforceable. The property is currently zoned R-4, High Density Residential. To ensure that multifamily and non-residential uses are not established in that single-family neighborhood counter to the intent of the original agreement (however unlikely), staff will be recommending rezoning these properties to R-1 to be consistent with the rest of the residential neighborhood. Staff has reached out to these property owners to explain the situation and proposes to rezone their properties to R-1, so staff is bringing that forward as a separate rezoning case before Council.

ANALYSIS

To the north, the property abuts a City-owned lot that is used as a stormwater detention basin, to the east is the Oak District assisted living facility, to the south is First Security State Bank and to the west is an undeveloped lot currently owned by First Security State Bank.

This request is unlike a typical rezoning request because the initial request restricted the usage of these two lots to professional office uses. The proposal is to execute a new zoning agreement to allow a use that is generally permitted in the R-4 district. All basic utility accommodations serve the property including sanitary sewer and a water main to each lot. The developer would utilize one connection and the other service connections will need to be abandoned at the developers cost. Vehicular access to the property is from Greenhill Circle.

The two lots in question are 1.09 acres in area. The site plan submitted mirrors the previous development showing a 9,813 square foot building with 16 units and 11 parking spaces to serve the staff and visitors, as most residents are unable to drive.

Based on the proposed development of Lots 5 and 6 in the Midway Business Park addition, staff supports this request to allow nursing homes and assisted living facilities in addition to professional offices by executing a new zoning agreement. The proposed use, assisted living, is allowed in the R-4 zoning district. Reviewing the case history of this zoning agreement and subsequent platting of the property, staff finds that this change to the zoning restrictions will be compatible with the surrounding neighborhood. The one-story building is similar in height to nearby homes and subject to similar building setbacks. Use of the property for supportive housing is consistent with the intended purpose of the zone. The traffic to the subject properties will not affect the surrounding residential properties because the only access to these lots is from Greenhill Circle via Greenhill Road.

The zoning agreement approved in 1994 and revised in 2018 will need to be rescinded and replaced by a new zoning agreement which accommodates the proposed assisted living facility. The new zoning agreement will only encompass the lots within the Midway Business Park and not the four single family lots at the end of Lovejoy.

Two notices were mailed to the adjoining property owners regarding this zoning district amendment. Notice of these rezone considerations was published in the WCF Courier on December 7, 2022 and notice of Council's hearing was published in the WCF Courier on January 6, 2023.

STAFF RECOMMENDATION

At their December 14 meeting, the Planning and Zoning Commission unanimously recommended approval of RZ22-003, a new zoning agreement that encompasses the Midway Business Park and restricts the uses to professional offices, nursing homes, and assisted living facilities. As part of this action, the resolutions approving the 1994 agreement and the 2018 amendment will be rescinded.

The Planning and Zoning Commission also recommends approval of a proper rezoning of the Midway Business Park to R-4 utilizing the correct legal description.

PLANNING & ZONING COMMISSION

Introduction
11/22/2022

The next item for consideration by the Commission was a request to rezone property in Midway Business Park to R-4 with a new Zoning Agreement. Acting Chair Hartley introduced the item and Mr. Sevy provided background information. He explained that staff brought forward a zoning agreement in September for this request and it was discovered through that process that there were some errors in the original legal description from the 1994 agreement. This consideration is more of a formality at this point since the commission previously voted in favor of the changes that the applicant has requested. At this time, staff proposes to replace the agreement as opposed to amending it, cleaning up provisions that have been fulfilled. Staff recommends setting a public hearing to consider a new zoning agreement that will encompass the Midway Business Park and restrict the uses to professional offices, nursing homes and assisted living facilities. The resolutions approving the 1994 agreement and the 2018 amendment will be rescinded. The new agreement will be brought forward at the public hearing. Staff also recommends setting a public hearing to consider a proper rezoning of the Midway Business Park to R-4 utilizing the correct legal description.

Ms. Crisman made a motion to approve move the item forward for public hearing. Mr. Larson seconded the motion. The motion was approved unanimously with 5 ayes (Crisman, Grybovych, Hartley, Larson and Moser), and 0 nays.

Public Hearing
12/14/2022

The first item of business was a public hearing for a new zoning agreement in Midway Business Park. Acting Chair Lynch introduced the item and Mr. Sevy provided background information. He explained that the property sits east of Cedar Heights Drive and north of Greenhill Road and the applicant would like to build an assisted living facility on Lots 5 and 6 which isn't permitted by the current zoning agreement. It is appropriate to execute a new zoning agreement and rezone to R-4 to update the zoning restriction and correct the legal description error discussed at the previous meeting. Staff recommends approval of the rezoning and the new zoning agreement.

Mr. Larson made a motion to approve the item. Ms. Grybovych seconded the motion. The motion was approved unanimously with 5 ayes (Crisman, Grybovych, Larson, Lynch and Moser), and 0 nays.

Attachments: Location map
Lots where assisted living facility is proposed
Request Letter
Original Zoning Agreement
New Agreement
Rezone Ordinance

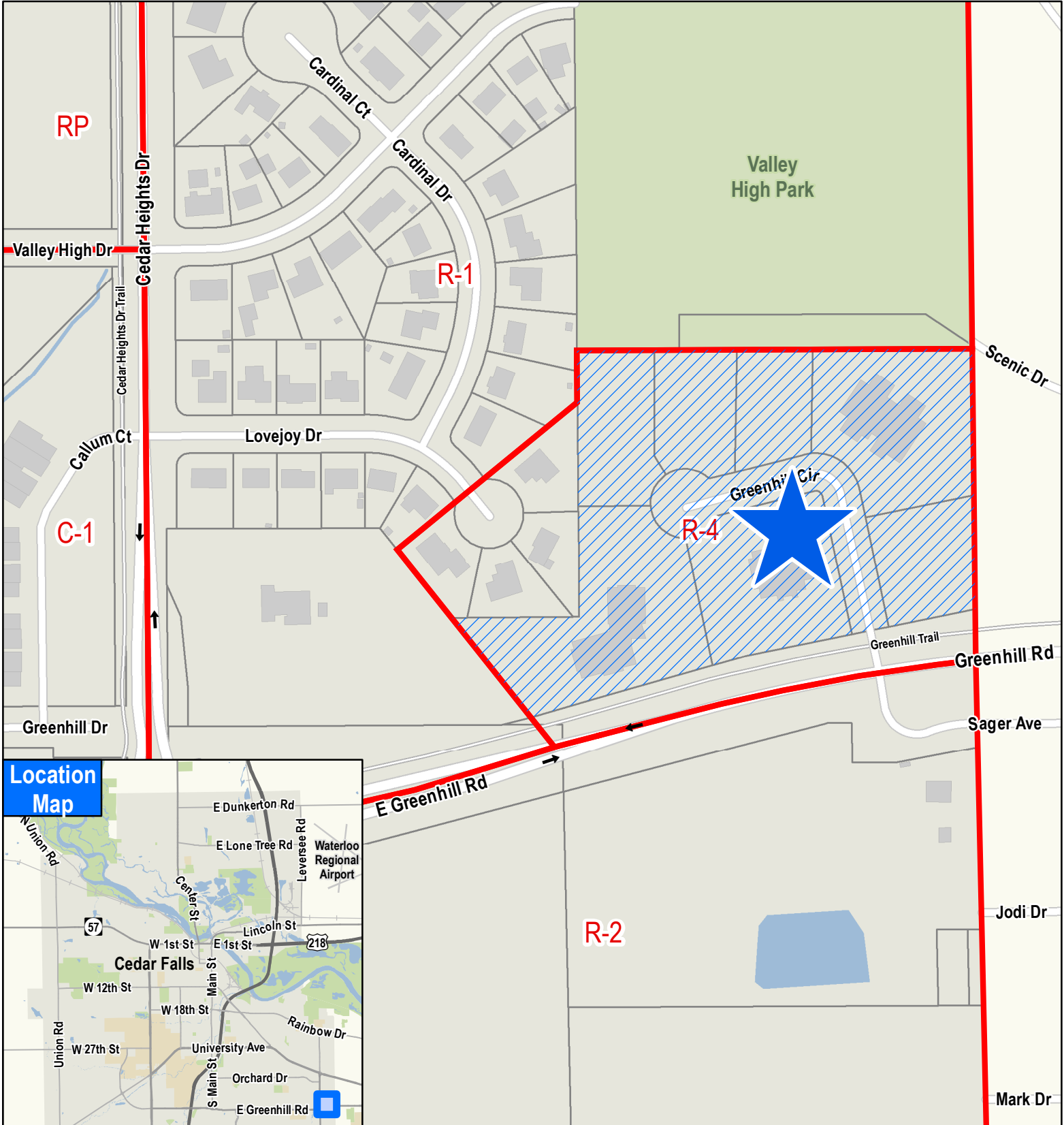

Location Map



**Zoning Agreement update & Rezone to R-4
Midway Business Park
All properties on Greenhill Circle**

FINAL PLAT MIDWAY BUSINESS PARK CEDAR FALLS, IOWA

LEGAL DESCRIPTION

That part of the Southwest Quarter (SW ¼) of Section Twenty (20), Township Eighty-nine (89) North, Range Thirteen (13) West of the Fifth Principal Meridian, in the City of Cedar Falls, Black Hawk County, Iowa, described as follows:

Commencing at the Southeast corner of said Southwest Quarter (SW ¼); thence N 0°41'32" E 180.64 feet to the Point of Beginning at the intersection of the East line of said SW ¼ and the Northerly right of way of Greenhill Road; thence S 80°00'00" W along said right of way 372.63 feet; thence S 75°28'38" W along said right of way 356.43 feet; thence N 37°27'26" W 203.11 feet; thence S 88°59'23" E 201.66 feet; thence N 1°00'37" E 424.01 feet to a point on the East line of Midway Addition which point is 595.00 feet North of the South line of said SW ¼; thence S 88°51'17" E 631.69 feet to a point on the East line of said SW ¼ which point is 595.00 feet North of the South line of said SW ¼; thence S0°42'21" W along the East line of said SW ¼ 414.93 feet to the Point of Beginning, containing 7.492 acres more or less, and is subject to easements and restrictions of record.

OWNER / DEVELOPER
FIRST SECURITY STATE BANK
3118 GREENHILL ROAD
CEDAR FALLS, IA 50613

- NOTES:
1) THE EAST LINE OF THE SOUTHWEST QUARTER IS ASSUMED TO BEAR N 0°42'21" E (A RECORD BEARING)
2) THE UNADJUSTED ERROR OF CLOSURE IS BETTER THAN 1:10,000
3) ALL DIMENSIONS ARE IN FEET AND DECIMALS THEREOF.

CURVE	LENGTH	RADIUS	CHORD	CHORD BRG
C1	14.95	10.50	13.72	N51°23'02"W
C2	68.44	55.00	64.11	N55°20'25"E
C3	44.83	55.00	43.60	S69°39'36"E
C4	41.58	55.00	40.80	S29°38'59"E
C5	55.37	55.00	53.06	S29°50'52"W
C6	71.89	55.00	66.80	N83°52'01"W
C7	13.76	70.50	13.74	S82°13'37"W
C8	65.12	70.50	62.83	N65°43'15"W
C9	35.28	70.50	34.92	N24°55'23"W

FEATURE LEGEND

- 5/8" CAPPED REBAR SET
- PROPERTY CORNER FOUND
- ▲ SECTION CORNER FOUND
- 100.00 DIMENSION OF SURVEY
- (100.00) DIMENSION OF RECORD
- Gas- EXISTING GAS
- Stm- EXISTING STORM SEWER
- San- EXISTING SANITARY SEWER
- Tel- EXISTING TELEPHONE
- Wat- EXISTING WATER
- EXISTING LIGHT POLE
- EXISTING UTILITY POLE
- EXISTING MANHOLE
- EXISTING FIRE HYDRANT
- EXISTING TREE

NORTH

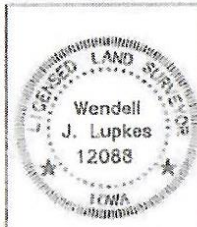
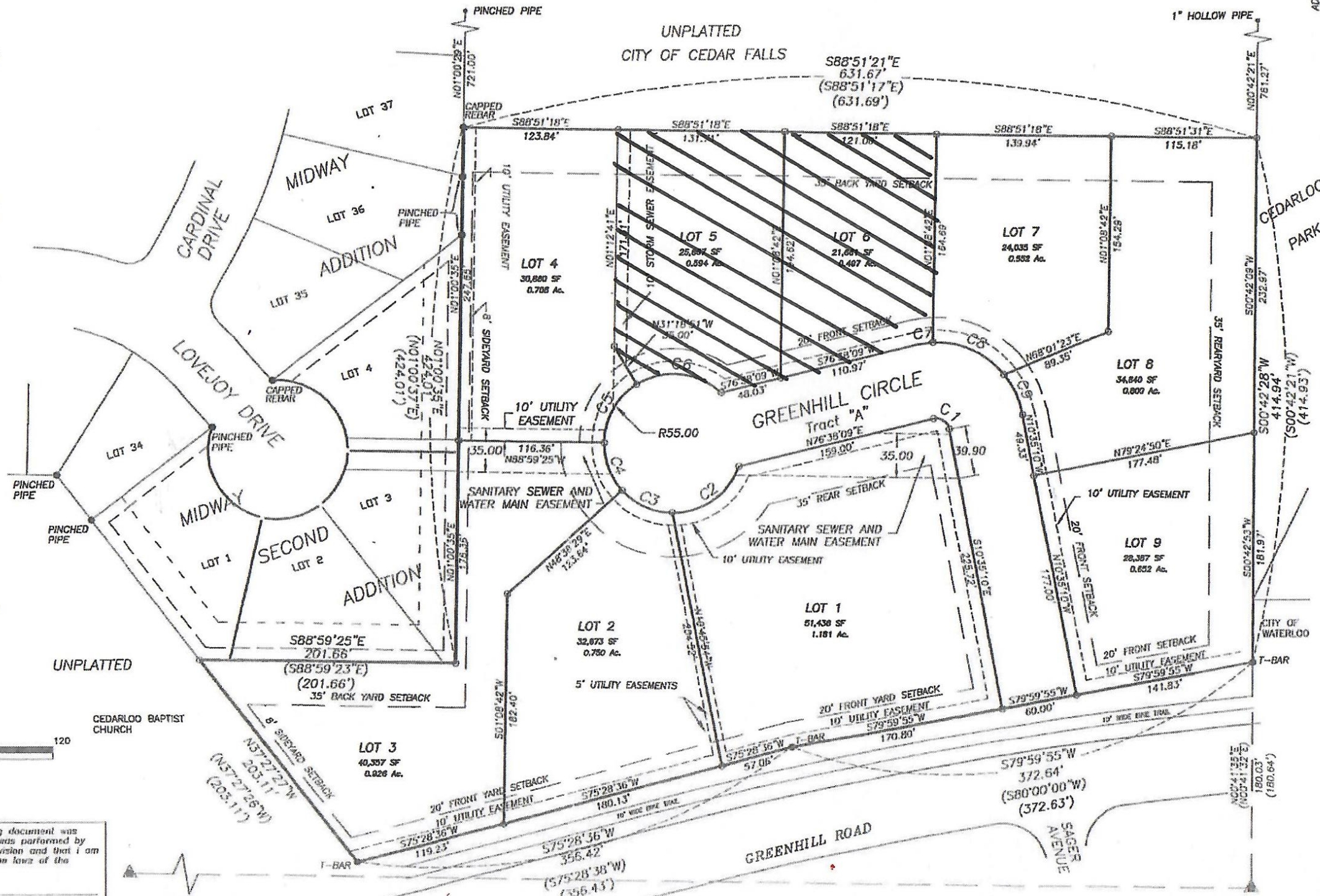
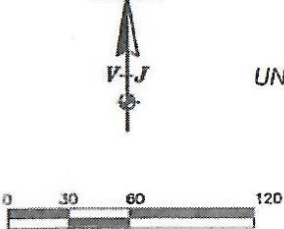

I hereby certify that this land surveying document was prepared and the related survey work was performed by me or under my direct personal supervision and that I am a duly licensed Land Surveyor under the laws of the State of Iowa.

WENDELL J. LUPKES, L.S. DATE
License number 12088
My license renewal date is December 31, 2004
Pages or sheets covered by this seal:

SW COR SE1/4, SW1/4
SEC. 20-89-13
"X" CUT ON CONC.

SE COR SW1/4 COR
SEC. 20-89-13
"X" CUT ON CONC.

NO.	DATE	BY	REVISIONS
1	11-20-02	WJL	ADDITIONAL 5' UTILITY EASEMENT (LOTS 1 & 2)

NO.	DATE	BY	REVISIONS
1	11-20-02	WJL	ADDITIONAL 5' UTILITY EASEMENT (LOTS 1 & 2)

NO.	DATE	BY	REVISIONS
1	11-20-02	WJL	ADDITIONAL 5' UTILITY EASEMENT (LOTS 1 & 2)

NO.	DATE	BY	REVISIONS
1	11-20-02	WJL	ADDITIONAL 5' UTILITY EASEMENT (LOTS 1 & 2)

van winkle-jacob engineering, inc.
1501 technology parkway
cedar falls, iowa - 319-266-5829

MIDWAY BUSINESS PARK, FINAL PLAT
CEDAR FALLS, IOWA

I would like to amend the zoning to lots 5 and 6 in the Midway Business park to allow for another assisted living building. We would be adding a much-needed service to Cedar Falls. Our current location has been a great success and a positive impact in the midway business park.

Luke Moore

COPY

ZONING AGREEMENT

This Agreement is made and entered into this 3th day of December, 1994, by and between R & N Investments, an Iowa Partnership, hereinafter called R & N Investments and the City of Cedar Falls, Iowa, hereinafter called City.

WHEREAS, R & N Investments is requesting a change in zoning for real estate described as follows:

Part of the Southeast Quarter of the Southwest Quarter of Section 20, Township 89 North, Range 13 West of the 5th P.M. in Cedar Falls, Black Hawk County, Iowa, described as follows: Beginning 180 feet north of the Southeast corner of said Southwest Quarter; thence North $0^{\circ}16'57''$ West 415 feet along the East line of said Southwest Quarter; thence North $89^{\circ}50'$ West along a line parallel to the South line of said Southwest Quarter to the East line of Midway Addition, in the City of Cedar Falls, Black Hawk County, Iowa; thence South $0^{\circ}0'20''$ West to the most Southeasterly corner of Lot 36 in of said Midway Addition; thence South $51^{\circ}36'20''$ West to the most Southerly corner of said Midway Addition; thence South $38^{\circ}23'40''$ East 357.72 feet to the South Quarter; thence North $19^{\circ}30'$ East a distance of 730 feet to the point of beginning.

from the R-1, Residential Zoning District to the R-4, Residential Zoning District, and

WHEREAS, Iowa Code Section 414.5 provides that a City Council may impose conditions on a property owner which are in addition to existing regulations if the additional conditions have been agreed to in writing by the property owner before the public hearing required under this Section or any adjournment of the hearing, and

WHEREAS, the City Council has determined that the additional conditions hereinafter provided are necessary to warrant a rezoning of the above described real estate.

NOW, THEREFORE, it is hereby agreed by and between the above named parties that the following conditions are hereby imposed on R & N Investments and the real estate described as follows in addition to the existing regulations governing all real estate included in the R-4, Residential Zoning District. Said conditions are as follows:

1. That a cul-de-sac street will be installed at the east end of Lovejoy Drive where single family residential lots will be established.

- 2. That the remaining property subject to rezoning east of the Lovejoy Drive cul-de-sac area will be developed solely with professional service office buildings.
- 3. That prior to the establishment of any uses on the property other than single family residences or professional service office buildings a separate rezoning request shall be submitted to the City for consideration in the normal fashion.

The foregoing conditions shall apply to the above described real estate and shall run with the land.

CITY OF CEDAR FALLS, IOWA



A. Miller Roskamp, Property Owner

By: 

Ed Stachovic, Mayor

ATTEST:



David M. Nordyke, Property Owner



Gary L. Hesse, City Clerk

STATE OF IOWA)
(ss:
BLACK HAWK COUNTY)

On this 8th day of December, 1994, before me, the undersigned, a Notary Public in and for the State of Iowa, personally appeared A. Miller Roskamp and David M. Nordyke, to me personally known, who, being by me duly sworn, did say they are the partners of R & N Investments, a partnership, and that the instrument was signed on behalf of the partnership by authority of the partners and the partners acknowledged the execution of the instrument to be the voluntary act and deed of the partnership by it and by the partners voluntarily executed.

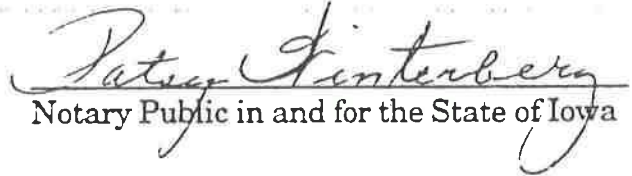
Notary Public in and for the State of Iowa

Preparer Information: Chris Sevy, Planner I, 220 Clay Street. Cedar Falls. IA 50613. (319)273-8600

ZONING AGREEMENT

This Agreement is made and entered into effective on this 3rd day of January, 2022, by and between First Security State Bank, the Community Foundation of Northeast Iowa, and Oak District Assisted Living, LLC (hereinafter the "Owners") and the City of Cedar Falls, Iowa (hereinafter the "City")

WHEREAS, a previous Zoning Agreement was approved by City Resolution No. 9798 on December 12, 1994 (hereinafter the "Previous Agreement"), on property described as follows:

Part of the Southeast Quarter of the Southwest Quarter of Section 20, Township 89 North, Range 13 West of the 5th P.M. in Cedar Falls, Black Hawk County, Iowa, described as follows; Beginning 180 feet north of the Southeast corner of said Southwest Quarter; thence North 0°16'57" West 415 feet along the East line of said Southwest Quarter; thence North 89°50' West along a line parallel to the South line of said Southwest Quarter to the East line of Midway Addition, in the City of Cedar Falls, Black Hawk County, Iowa; thence South 0°0'20" West to the most Southeasterly corner of Lot 36 in said Midway Addition; thence South 51°36'20" West to the most Southerly corner of said Midway Addition; thence South 38°23'40" East 357.72 feet to the South Quarter; thence North 19°30' East a distance of 730 feet to the point of beginning.

WHEREAS, the above property description contains errors and is not indicative of the property that was originally intended to be rezoned on City records in conjunction with the Previous Agreement; and

WHEREAS, an amendment to the Previous Agreement was approved by City Council Resolution No. 21,212 on August 6, 2018 (hereinafter the "Amendment"), which cited the same property description as in the Previous Agreement and

amended the Previous Agreement to restrict the uses on Lots 7 and 8 of the Midway Business Park to professional offices, nursing homes, and senior assisted living facilities; and

WHEREAS, the Owners of all property intended to be subject to the Previous Agreement are requesting another change to allow nursing homes and assisted living facilities, in addition to professional offices, on Lots 5 & 6 of the Midway Business Park; and

WHEREAS, the City Council finds it in the best interest of the City to rescind the Prior Agreement and the Amendment, to rezone the property described below to R-4, which is the property intended to be rezoned and intended to be subject to the zoning agreement, and to enter into a new zoning agreement that applies to the property described below; and

WHEREAS, Iowa Code 414.5, as amended, provides that a City Council may impose reasonable conditions on granting an applicant's rezoning request, over and above existing regulations, in order to satisfy public needs directly caused by the requested change; and

WHEREAS, Owners all agree that a new Zoning Agreement, to replace the Prior Agreement and the Amendment, be executed which reflects the intent of the Owners and the City to restrict the uses within the business park to ensure compatibility with the adjacent residential neighborhood; and

WHEREAS, All provisions of the Previous Agreement and Amendment, other than the aforementioned use restrictions, have been satisfied.

NOW THEREFORE, it is hereby agreed by and between the above-named parties that:

1. The property subject to this Zoning Agreement is legally described as

MIDWAY BUSINESS PARK, CEDAR FALLS, BLACK HAWK COUNTY, IOWA

2. In addition to the existing regulations governing all real estate included in the R-4, Residential Zoning District, in the City of Cedar Falls, the following condition is hereby imposed on the owners and the real estate described above as follows:
 - a. The development of the Midway Business Park shall be restricted to professional offices, nursing homes, and assisted living facilities only.
3. The foregoing condition and this Zoning Agreement shall inure to the benefit of and shall be binding upon each of the Owners and their respective heirs, personal representatives, successors and assigns, and shall run with the land which

4. Cedar Falls City Council Resolution No. 9798, dated December 12, 1994, and Resolution No. 21,212 dated August 6, 2018, are hereby rescinded in their entirety and shall have no further effect.

IN WITNESS WHEREOF, the Owners and the City have executed this Zoning Agreement as of the date first stated above.

FIRST SECURITY STATE BANK

By Dennis M. Hansen

Title President

STATE OF IOWA, COUNTY OF BLACK HAWK, ss:

This record was acknowledged before me on the 3rd day of January, ~~2022~~²⁰²³ by Dennis Hansen, as President of First Security State Bank.

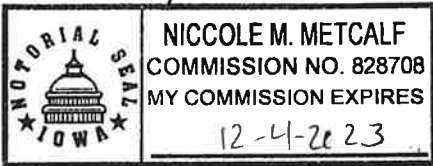

Nicole M. Metcalf
Notary Public in and for the State of Iowa

My Commission Expires:
12-4-2023

COMMUNITY FOUNDATION OF NORTHEAST IOWA

By Elizabeth Kurtz

Title Vice President of Finance & Operations

STATE OF IOWA, COUNTY OF BLACK HAWK, ss:

This record was acknowledged before me on the 5th day of January, ~~2022~~²⁰²³ by Elizabeth Kurtz, as Vice President of Finance Operations of Community Foundation of Northeast Iowa.

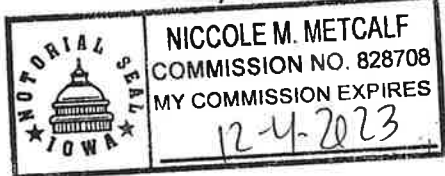

Niccole M. Metcalf
Notary Public in and for the State of Iowa

My Commission Expires:
12-4-2023

OAK DISTRICT ASSISTED LIVING, LLC

By [Signature]

Title owner

STATE OF IOWA, COUNTY OF BLACK HAWK, ss:

This record was acknowledged before me on the 3rd day of January, ~~2022~~²⁰²³ by Duke Moore, as owner of Oak District Assisted Living, LLC.

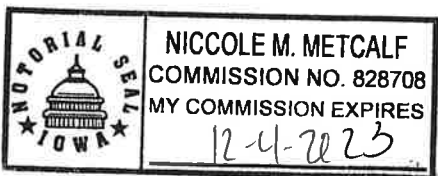

Niccole M. Metcalf
Notary Public in and for the State of Iowa

My Commission Expires:
12-4-2023

CITY OF CEDAR FALLS, IOWA

By _____
Robert M. Green, Mayor

ATTEST:

Jacqueline Danielsen, MMC, City Clerk

Prepared by: Chris Sevy, Planner I, 220 Clay Street, Cedar Falls, IA 50613 (319) 273-8600

ORDINANCE NO. _____

AN ORDINANCE CONDITIONALLY REZONING APPROXIMATELY 7.49 ACRES OF LAND DESCRIBED HEREIN TO THE R-4 MULTIPLE RESIDENCE DISTRICT, AMENDING THE ZONING MAP OF THE CITY OF CEDAR FALLS, IOWA ACCORDINGLY, AND ADOPTING THE CONDITIONAL ZONING AGREEMENT ATTACHED HERETO AND INCORPORATED HEREIN

WHEREAS, a rezoning from the R-1, Residential Zoning District to the R-4, Multiple Residence District was approved by City Ordinance No. 2080 on January 9, 1995, which ordinance contained a legal description that contained errors, such that the ordinance was not indicative of the property that was originally intended to be rezoned as per City records; and

WHEREAS, a Zoning Agreement was adopted by City Resolution No. 9798 on December 12, 1994 (hereinafter the "Previous Agreement") which cited the same property legal description containing errors; and

WHEREAS, an amendment to the Previous Agreement was approved by City Council Resolution No. 21,212 on August 6, 2018 (hereinafter the "Amendment"), which cited the same property description as in the Previous Agreement and amended the Previous Agreement to restrict the uses on Lots 7 and 8 of the Midway Business Park to professional offices, nursing homes, and senior assisted living facilities; and

WHEREAS, the Owners of all property intended to be subject to the Previous Agreement are requesting another change to allow nursing homes and assisted living facilities, in addition to professional offices, on Lots 5 & 6 of the Midway Business Park; and

WHEREAS, Iowa Code 414.5, as amended, provides that a City Council may impose reasonable conditions on granting an applicant's rezoning request, over and above existing regulations, in order to satisfy public needs directly caused by the requested change; and

WHEREAS, Owners all agree that a New Zoning Agreement, to replace the Previous Agreement and the Amendment, be executed which reflects the intent of the Owners to restrict the uses on properties within the Midway Business Park to nursing homes, assisted living facilities and professional offices only, and that all other provisions of the Previous Agreement and Amendment have been satisfied; and

WHEREAS, under case number RZ22-003, the City Planning and Zoning Commission of the City of Cedar Falls, Iowa, has recommended approval of a rezoning of the property described below to R-4 Multiple Residence District, subject to the New Zoning Agreement that restricts use of the properties to

professional offices, nursing homes, and assisted living facilities, to ensure compatibility with the adjacent residential neighborhood (hereinafter the “New Zoning Agreement”); and

WHEREAS, the City Council finds it in the best interest of the City to rezone the property described below to R-4, Multiple Residence District, pursuant to the New Zoning Agreement attached hereto, and by this reference incorporated herein as fully as though set out in this ordinance, which conditions are hereby imposed upon the property owners, their successors and assigns, and upon the real estate described below, and shall run with the land; and

WHEREAS, the said Section 26-118, District Boundaries of Division I, Generally, of Article III, Districts and District Regulations, of Chapter Twenty-Six (26), Zoning, of the Code of Ordinances of the City of Cedar Falls, Iowa, provides that the zoning map of the City of Cedar Falls, Iowa, is incorporated into and made a part of said Ordinance; and

WHEREAS, notice of public hearing has been published, as provided by law, and such hearing held on the proposed amendment.

NOW, THEREFORE, BE IT ORDAINED BY THE CITY COUNCIL OF THE CITY OF CEDAR FALLS, IOWA:

Section 1. That the following described real estate, be and the same is hereby added to the R-4, Multiple Residence District:

Legal Description:

MIDWAY BUSINESS PARK, CEDAR FALLS, BLACK HAWK COUNTY, IOWA

Section 2. That the zoning map of the City of Cedar Falls, Iowa, be and the same is hereby amended to show the property described in Section 1, above, as now being in the R-4, Multiple Residence District, pursuant to a New Zoning Agreement that has been made a part of this ordinance, and the amended map is hereby ordained to be the zoning map of the City of Cedar Falls, Iowa, as amended.

Section 3. That City Council Resolution No. 9798 and City Council Resolution No. 21,212 are hereby rescinded.

INTRODUCED: _____

PASSED 1ST CONSIDERATION: _____

PASSED 2ND CONSIDERATION: _____

PASSED 3RD CONSIDERATION: _____

ADOPTED: _____

Robert M. Green, Mayor

ATTEST:

Jacqueline Danielsens, MMC, City Clerk



DEPARTMENT OF COMMUNITY DEVELOPMENT

City of Cedar Falls
 220 Clay Street
 Cedar Falls, Iowa 50613
 Phone: 319-273-8600
 Fax: 319-273-8610
 www.cedarfalls.com

MEMORANDUM

Planning & Community Services Division

TO: Honorable Mayor Robert M. Green and City Council
FROM: Chris Sevy, Planner I
DATE: January 17, 2023
SUBJECT: Rezone Midway 2nd Addition

REQUEST: Rezone from R-4 to R-1

PETITIONER: City of Cedar Falls

LOCATION: Lots 1-4 of Midway 2nd Addition (3019-3028 Lovejoy Dr) (RZ22-005)

PROPOSAL

The zoning agreement that restricts the use of these lots to single family in the R-4 District is in the process of being rescinded and replaced as errors were discovered in the legal description while updating the restrictions in that agreement. The agreement has served its purpose in the establishment of single-family uses, and it makes more sense at this time to regulate these lots the same as the rest of the residential neighborhood. To ensure that the use of these lots remains consistent with the residential neighborhood, staff proposes that they be rezoned from R-4 to R-1.

BACKGROUND

In the process of preparing an amendment to the zoning agreement it was discovered that there was an error in the legal description included in the original zoning agreement from 1994 so it did not accurately describe the same properties that were rezoned to R-4 at the time. Since this error nullifies the agreement and any subsequent amendments, it is best to rescind the original agreement and draft a new one that includes the conditions that remain relevant today, specifically the use restrictions in the Midway Business Park.

The other two conditions of the original 1994 agreement have already been accomplished. Namely, Lovejoy Drive ends in a cul-de-sac, and four single family homes have been constructed on the four lots at the end of Lovejoy. This effectively separates the residential neighborhood from the Midway Business Park, so no commercial traffic can flow through the neighborhood (see aerial image below).

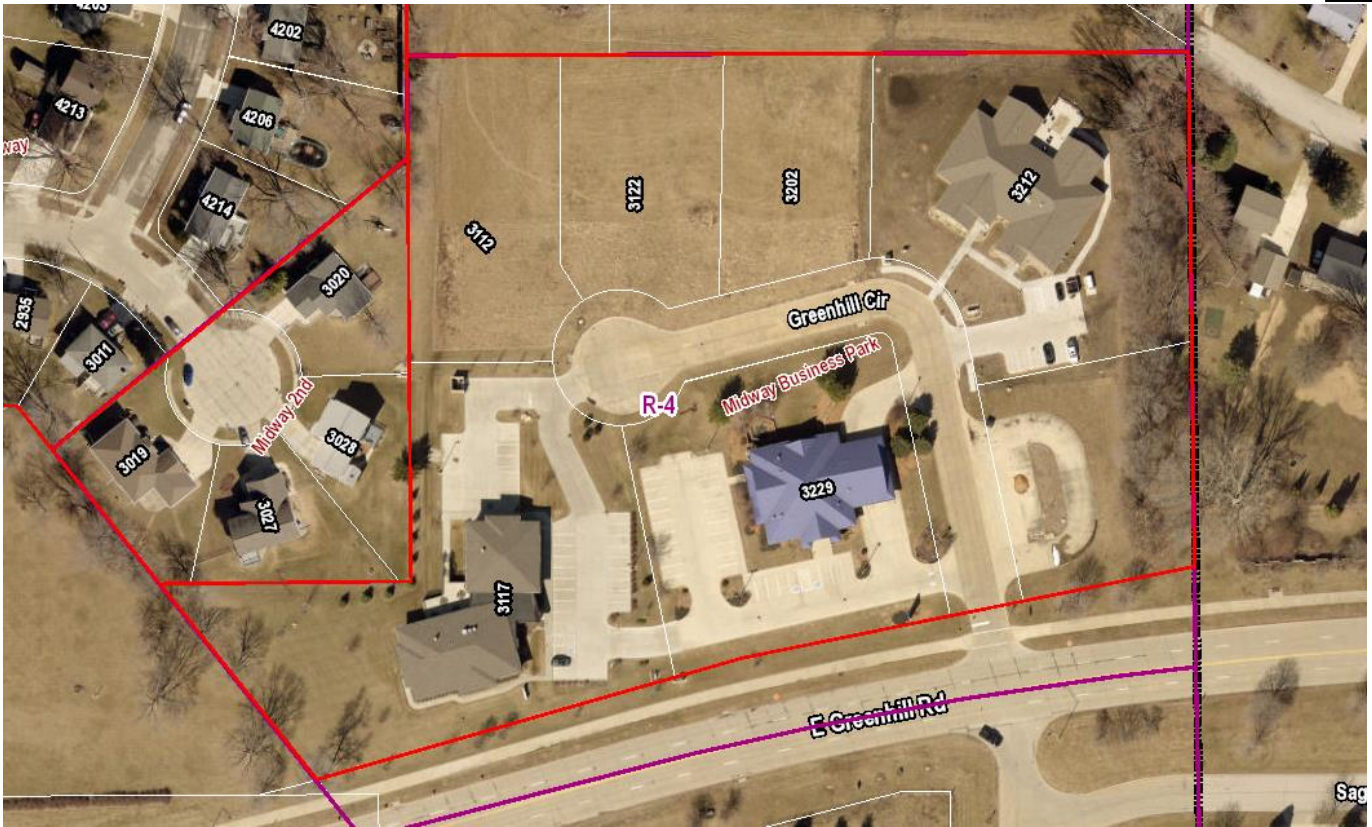

The four residential properties at the end of Lovejoy Drive are currently zoned R-4, High Density Residential. To ensure that multifamily and non-residential uses are not established in that single-family neighborhood counter to the intent of the original agreement (however unlikely), staff is recommending rezoning these properties to R-1 to be consistent with the rest of the residential neighborhood. Staff has reached out to these property owners to explain the situation and discuss rezoning their properties to R-1.

ANALYSIS

By virtue of the errors in the legal description of the original zoning agreement, the enforceability of that agreement is in question. The city is in the process of rescinding and replacing the agreement which leaves two options:

1. Include the residences in the new zoning agreement and continue to regulate the residences in that way, or
2. Rezone the residences to R-1 and regulate them the same as the adjacent homes in the neighborhood, which is zoned R-1.

Since, for some time these have not been considered part of the Midway Business Park but an addition to the Midway Subdivision, the latter option appears to be more appropriate. Also, rezoning to R-1 better defines the rights of the property owners.

Worth noting is that there are platted 20-foot front setbacks that will continue to apply to these properties. All other aspects of R-1 District standards will apply.

MINIMUM CRITERIA FOR REZONE

The following criteria are the minimum consideration for a rezone:

1) *Is the rezoning request consistent with the Future Land Use Map and the Comprehensive Plan?*

Yes, these residences are slated for Low Density Residential on the Future Land Use Map

2) *Is the property readily accessible to sanitary sewer service?*

Yes, these are developed lots and each residence is connected to utilities.

3) *Does the property have adequate roadway access?*

Yes, the lots are on a cul-de-sac at the end of Lovejoy Drive.

Notice was mailed to the adjoining property owners on September 6, 2022 regarding the zoning agreement amendment. Additional notice was mailed on November 4, 2022 regarding the change of course to rescind and replace the agreement. Lastly, notice was mailed on November 16th, 2022 regarding this rezone from R-4 to R-1.

Notice of public hearing regarding these rezone considerations was published in the WCF Courier on December 7, 2022 and notice of Council’s hearing was published in the WCF Courier on January 6, 2023.

STAFF RECOMMENDATION

The Planning and Zoning Commission reviewed this proposal and unanimously recommends approval of a rezoning of the subject properties from R-4 to R-1.

PLANNING & ZONING COMMISSION

Introduction
11/22/2022

The next item for consideration a rezoning request for Lots 1-4 of Midway 2nd Addition. Acting Chair Hartley introduced the item and Mr. Sevy provided background information. He explained that Lots 1-4 were part of the original agreement discussed in the previous item. One of the stipulations was that both streets would end in a cul-de-sac and these lots would be restricted to residential uses and be zoned R-4. Because R-4 has several other uses that are not considered residential, the zoning would need to be changed to R-1 for these lots so as to be regulated the same as the other residential parcels in the neighborhood. Staff recommends setting a public hearing to consider rezoning the subject properties from R-4 to R-1.

Mr. Larson thanked the developer for bringing a great project to the area and apologized for any unplanned delays.

Mr. Larson made a motion to move the item to public hearing. Ms. Moser seconded the motion. The motion was approved unanimously with 5 ayes (Crisman, Grybovych, Hartley, Larson and Moser), and 0 nays.

Public Hearing
12/14/2022

The next item for consideration by the Commission was a public hearing regarding a rezoning of Lots 1-4 in the Midway 2nd Addition. Acting Chair Lynch introduced the item and Mr. Sevy provided background information. He explained that the previous rezoning to R-4 with an associated zoning agreement was intended to encompass a larger area that included the Lovejoy cul-de-sac. However, the legal description in the previous zoning action years ago has an error, so the properties need to be rezoned with the correct legal description. Since these four lots are at the end of a cul-de-sac that does not connect to the Midway Business Park and have already been developed with single family homes, the City is proposing to rezone these lots to R-1, so the zoning is consistent with the rest of the residential neighborhood.

Ms. Moser made a motion to approve the item. Mr. Larson seconded the motion. The motion was approved unanimously with 5 ayes (Crisman, Grybovych, Larson, Lynch and Moser), and 0 nays.

Attachments: Location map
Rezoning Ordinance

Cedar Falls City Council January 17, 2023

Item 5.

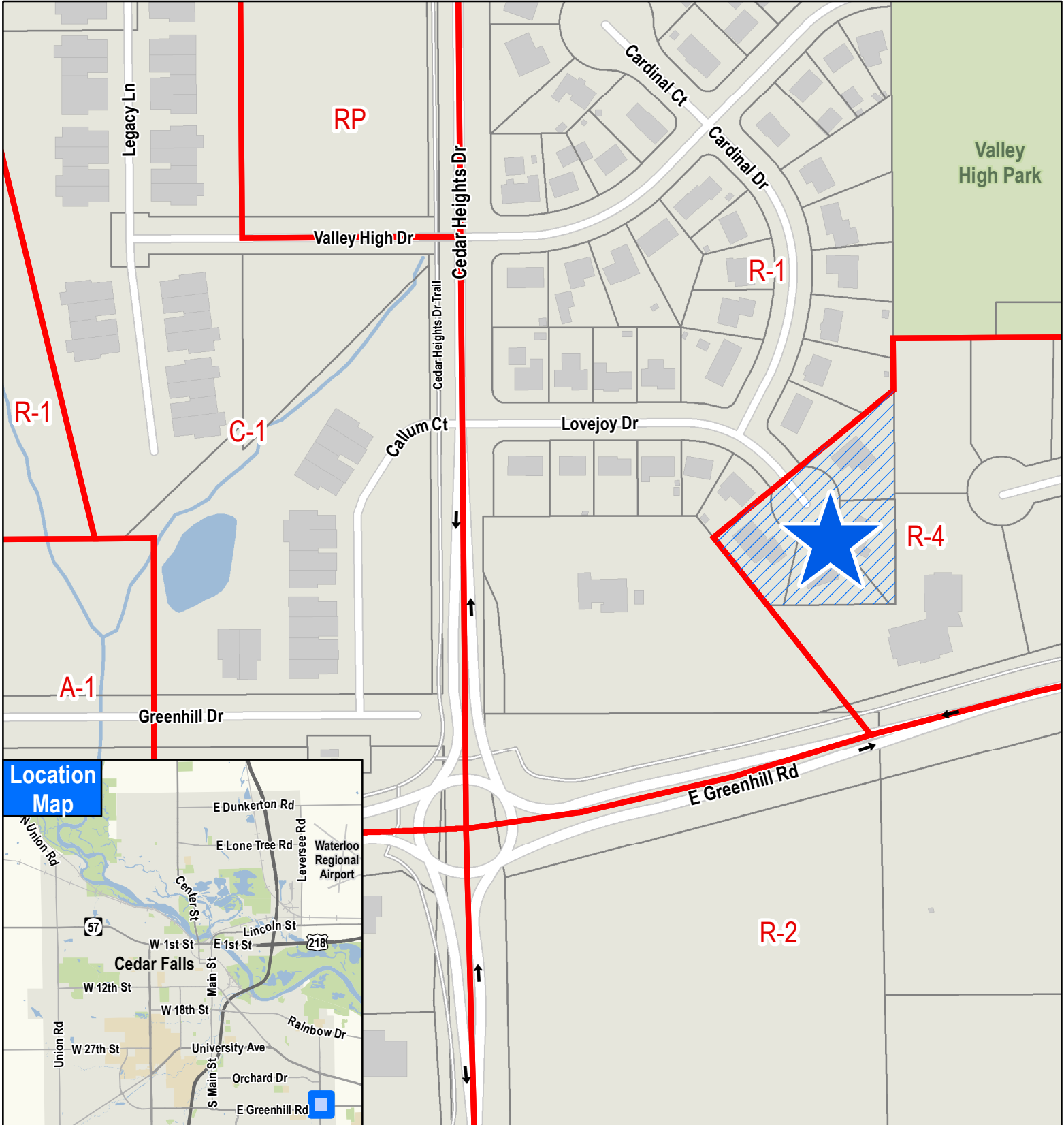

Location Map

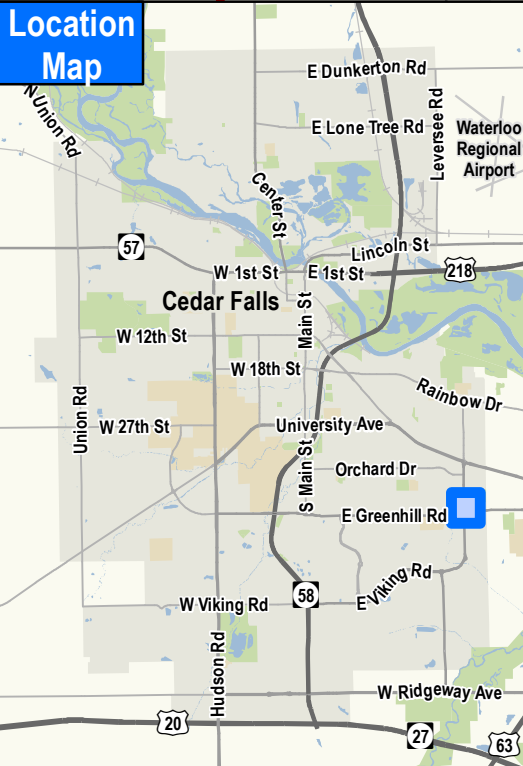

**Rezone from R-4 to R-1
Lots 1 through 4, Midway 2nd Addition
3019, 3020, 3027, 3028 Lovejoy Dr.**

Prepared by: Chris Sevy, Planner I, 220 Clay Street, Cedar Falls, IA 50613 (319) 273-8600

ORDINANCE NO. _____

AN ORDINANCE AMENDING THE ZONING MAP OF THE CITY OF CEDAR FALLS, IOWA FOR APPROXIMATELY 1.44 ACRES OF LAND DESCRIBED HEREIN, REMOVING SAID AREA FROM THE R-4, MULTIPLE RESIDENCE DISTRICT AND ADDING IT TO THE R-1, RESIDENCE DISTRICT

WHEREAS, a proposal was submitted to the Cedar Falls Planning and Zoning Commission to rezone approximately 1.44 acres of property from R-4, Multiple Residence District to R-1, Residence District, more specifically described below; and

WHEREAS, the City Planning and Zoning Commission of the City of Cedar Falls, Iowa, finds that the rezoning (Case #RZ22-005) is consistent with the adopted Comprehensive Plan of the City of Cedar Falls and therefore has recommended to the City Council of the City of Cedar Falls, Iowa, that the property described below shall be removed from the R-4, Multiple Residence District and placed in the R-1, Residence District; and

WHEREAS, the City Council of the City of Cedar Falls, Iowa, deems it to be in the best interests of the City of Cedar Falls, Iowa, that said proposal be made and approved; and

WHEREAS, the said Section 26-118, District Boundaries of Division I, Generally, of Article III, Districts and District Regulations, of Chapter Twenty-Six (26), Zoning, of the Code of Ordinances of the City of Cedar Falls, Iowa, provides that the zoning map of the City of Cedar Falls, Iowa, attached thereto, is incorporated into and made a part of said Ordinance;

WHEREAS, notice of public hearing has been published, as provided by law, and such hearing held on the proposed amendment.

NOW, THEREFORE, BE IT ORDAINED BY THE CITY COUNCIL OF THE CITY OF CEDAR FALLS, IOWA:

Section 1. That the following described real estate, be and the same is hereby removed from the R-4, Multiple Residence District and added to the R-1, Residence District:

Legal Description

MIDWAY SECOND ADDITION, CEDAR FALLS, IOWA

Section 2. That the zoning map of the City of Cedar Falls, Iowa, be and the same is hereby amended to show the property described in Section 1, above, as now being in the R-1, Residence

District, and the amended map is hereby ordained to be the zoning map of the City of Cedar Falls, Iowa, as amended.

INTRODUCED: _____

PASSED 1ST CONSIDERATION: _____

PASSED 2ND CONSIDERATION: _____

PASSED 3RD CONSIDERATION: _____

ADOPTED: _____

ATTEST:

Robert M. Green, Mayor

Jacqueline Danielsen, MMC, City Clerk

CITY COUNCIL WORK SESSION

Cedar Falls City Hall Conference Room 2
January 3, 2023

The City Council held a work session at City Hall at 5:50 p.m. on Tuesday, January 3, 2023, with the following persons in attendance: Mayor Rob Green, Susan deBuhr, Daryl Kruse, Simon Harding, Dustin Ganfield, Dave Sires, and Kelly Dunn. Absent: Gil Schultz. Staff members attended from all City Departments and members of the community attended in person.

Mayor Green called the meeting to order. The roll was called. Mayor Green introduced the only item on the agenda, Council Policy Development. Mayor Green reviewed a memo, chart, and City Ordinance policy authority information outlining a proposal for consistent City policy development, review, approval, and oversight based on current City Ordinances. Mayor Green opened for discussion. Councilmembers discussed final policy approval by Council; appropriateness of Council approval for updated Public Safety policies; pros and cons of approval of policies by Council individually or by "receive and file"; how to balance not micro-managing staff with the final authority of Council; continuation of Council final approval of Personnel Policies; Council review and approval of Police and Fire Standard Operating Guides and Emergency Operation Plan. Councilmember Harding suggested creating a list of what Council should have to approve individually versus "receive and file". Councilmembers also requested to see a list of current policies and how they are approved at a future meeting.

There being no further discussion, Mayor Green adjourned the meeting at 6:15 p.m.

Minutes by Katie Terhune, Administrative Assistant

MEETING OF STANDING COMMITTEES

City Hall, 220 Clay Street

January 3, 2023

The meeting of Standing Committees met at City Hall at 6:21 p.m. on January 3, 2023, with the following Committee persons in attendance: Councilmembers Susan deBuhr, Kelly Dunn, Simon Harding, Daryl Kruse, Dustin Ganfield, and Dave Sires; absent: Gil Schultz. Staff members from all City Departments and members of the community attended in person.

Finance & Business Operations Committee:

Chair Dunn called the meeting to order and introduced the only item on the Finance & Business Operations Committee Agenda, Annual Report of Library and introduced the Library Director, Kelly Stern. Director Stern gave an update on the FY22 Annual Report which included the following highlights: 131,460 physical items and 13,587 downloadable items checked out in FY22; patron visits have increased since last year. Director Stern stated the library is also working on building relationships to serve local needs and interests; diversity & inclusion; discovery, education & learning; connectedness of collection, learning, and programs (gardening programs, worm farm, decomposition of pumpkins, and a mobile kitchen). Director Stern stated upcoming items at the library will include a new brand, new and expanded partnerships; continued accessibility enhancements; greater diversity in programs and food education and cooking demos with the Charlie Cart. No questions from Councilmembers.

Public Safety Committee:

Chair Ganfield called the meeting to order and introduced the only item on the Public Safety Committee Agenda, RETF items implemented by Public Safety and introduced Director of Public Safety, Craig Berte. Director Berte stated the Racial Equity Task Force had given recommendations in the Fall of 2021 that included education, housing and policing. Director Berte introduced Police Chief Mark Howard; Chief Howard gave an outline of items that are now practices/upcoming implementation and how they integrate with the Public Safety's 5-year strategic plan. Items in the outline included: Crisis Intervention Team; de-escalation scenario training; changes in the formal complaint process; establishing partnerships in the community; ability of officers to take patrol cars home; recruiting at colleges/athletic departments and out of state/Cedar Valley recruitment; continuing to work with HRC; new recruiting video and brochure; investing in our officers' wellness and advancements within the department for retention; educational assistance and competitive pay. Chief Howard discussed traffic stops and arrests from 2020-2022 and the Police division's diversity currently. Councilmembers discussed National Night Out, diversity, adding a social worker to staffing, and yard signs.

Meeting adjourned at 6:57 p.m.

Minutes by Kim Kerr, Administrative Supervisor



MAYOR ROBERT M. GREEN

CITY OF CEDAR FALLS, IOWA
220 CLAY STREET
CEDAR FALLS, IOWA 50613
PHONE 319-273-8600
FAX 319-268-5126
www.cedarfalls.com

FROM: Mayor Robert M. Green
TO: City Council
DATE: January 10, 2023
SUBJECT: Reappointment of Shirley Merner to the Health Trust Fund Board of Trustees
REF: (a) Code of Ordinances, City of Cedar Falls §2-364
(b) CFD 1201.22d – Appointment Process for Boards and Commissions

1. In accordance with the candidacy and qualification requirements of reference (a), I hereby nominate the following for reappointment to the Cedar Falls Health Trust Fund Board of Trustees a six-year term, as their current terms expired on December 31, 2022:
 - Ms. Shirley Merner (Reappointment) – Term ends 12/31/2028
2. The board service of this board member has been reviewed by City staff. She had satisfactory attendance and has actively been contributing to the work of the Board; she has agreed to serve for an additional term if approved by the City Council.
3. Although Ms. Merner has surpassed twenty years of service (with an original appointment of 2/24/1997), I am making an exception to the twenty-year cap described in reference (b). This decision is due to the historical difficulty of finding members to serve on this board.
4. Please contact me if you have any questions about the above appointment.

Xc: City Administrator
Director, Finance and Business Operations

###



DEPARTMENT OF PUBLIC SAFETY SERVICES

POLICE OPERATIONS
CITY OF CEDAR FALLS
4600 SOUTH MAIN STREET
CEDAR FALLS, IOWA 50613

319-273-8612

MEMORANDUM

To: Mayor Green and City Councilmembers
From: Craig Berte, Public Safety Services Director
Mark Howard, Police Chief
Date: January 9, 2023
Re: Retail Alcohol License Applications

Police Operations has received applications for retail alcohol licenses. We find no records that would prohibit these licenses and recommend approval.

Name of Applicants:

- a) College Square Cinema, 6301 University Avenue, Special Class C retail alcohol - renewal.
- b) Fraternal Order of Eagles, 2125 West Lone Tree Road, Class C retail alcohol & outdoor service - renewal.
- c) Kwik Spirits, 4116 University Avenue, Class E retail alcohol - renewal.



DEPARTMENT OF FINANCE & BUSINESS OPERATIONS

CITY OF CEDAR FALLS, IOWA
220 CLAY STREET
CEDAR FALLS, IOWA 50613
319-273-8600
FAX 319-268-5126

INTEROFFICE MEMORANDUM

TO: Mayor Green & City Council Members
FROM: Lisa Roeding, Controller/City Treasurer
DATE: January 6, 2023
SUBJECT: Updated Purchasing Manual

Attached are Sections 11 and 28 of Accounting Policies and Procedures and Purchasing Manual. These sections have been updated to incorporate the following revisions:

- Section 11: Public improvement bidding threshold requirements as set by the State of Iowa have been updated
- Section 28: has been updated to adhere to the guidance in State Auditor opinion statements dated May 2020 and November 2021, ensuring public purpose is served when directing public funds toward a private non-profit.

If you have any questions regarding the manual, please feel free to contact me.

CC: Jennifer Rodenbeck, Director of Finance & Business Operations

SECTION 11

QUOTATIONS AND BIDS

11.01 BASIS FOR QUOTATIONS OR BIDS:

When a department determines a need to purchase an item, that department will seek a source of the requested materials and/or services.

1. Requirements for solicitation of bids and quotations: The material and/or services requested and approved for purchase are of significant value and/or of a competitive nature.
2. Exemptions from competitive quotation and bidding procedures:
 - a. Repair parts of a sole source nature shall be exempt from competitive quotation and bidding procedures.
 - b. Specialized services shall be exempt from the competitive quotation and bidding process, as deemed appropriate by the Director of Finance & Business Operations except as required by State Law.
 - c. Specialized items of a technical nature shall be exempt from competitive quotation and bidding procedures, except as required by State Law.
 - d. Utilization of State of Iowa, General Services Administration (GSA), National IPA, OMINIA Partners, US Communities, or other state or federal joint purchasing cooperations. Competitively bid State of Iowa or other state or federal contracts available to political subdivisions may be utilized in lieu of soliciting written bids or verbal quotation for the purchase of commodities and services.
3. Special Conditions:
 - a. Proof of insurance: Proof of insurance may be required for public improvement projects, services to be performed on City property, or other contracts for equipment or services. The amount of coverage required shall be based on risk factors and determined by the City's Risk Management Committee.
 - b. Affirmative Action compliance: The City of Cedar Falls adheres to Local, State, and Federal Laws which require that businesses providing goods and services to the City of Cedar Falls are Equal Opportunity Employers. Any contract entered into by the City of Cedar Falls in accordance with this policy ensures that disadvantaged business enterprises will be afforded full

opportunity to submit bids in response to request for bids. They will not be discriminated against on the grounds of race, color, or national origin in consideration of the contract award.

- c. The responsible bid requirement focuses on the bidder, which means the bid is submitted by a bidder who has the financial and technical ability to perform and complete the required work. The responsive bid requirement focuses on the bid and is a check to ensure the bidder agrees to all that is required in the plans, specifications and other requirements of the project.

4. Unique Requirements of Government Contracts

- a. All purchases funded through a State or Federal grant must follow all additional procedures required by the grantor. All bid specifications for a purchase that is funded through a State or a Federal grant must list all additional specifications for the goods or services that are required by the grantor. Any contract funded through a federal grant shall comply with 2 CFR 200.318 through 200-326 and Appendix II to Part 200.
- b. Contractors must be evaluated when bids are received on their ability to meet State or Federal requirements. The City will not award a federally funded contract to a party listed as debarred, suspended, or otherwise excluded in the System for Award Management (SAM). www.sam.gov

In addition, no purchases to be covered by a grant can be made prior to the execution of the grant agreement unless approved by the grantor.

11.02 PUBLIC IMPROVEMENT (VERTICAL INFRASTRUCTURE) BIDDING PROCEDURES:

Formal bidding procedures will be used exclusively for public improvement projects in excess of the minimum threshold amount as determined by the State of Iowa- ~~(\$139,000 1/1/19)~~ and in accordance with Chapter 26 of the Code of Iowa. [Iowa Code Section 314.1B establishes vertical bid thresholds for city projects. These thresholds may adjust each year effective January 1.](#) -A public improvement project is defined as a building or construction work which is contracted under the control of a governmental entity and is paid for in whole or in part with funds of the governmental entity, including a building or improvement constructed or operated jointly with any other public or private agency, but excluding urban renewal demolition and low-rent housing projects, industrial aid projects authorized under chapter 419, emergency work or repair or maintenance work performed by employees of a governmental entity, and excluding a highway, bridge, or culvert project, and excluding construction or repair or maintenance work performed for a city utility under chapter 388 by its employees or performed for a rural water district under chapter 357A by its employees. For highway, bridge, and culvert projects

please refer to section 11.03 below.

1. A "Notice of Request for Bids" shall be posted in three separate places (as noted below) not less than thirteen (13) nor more than forty-five (45) days before the bid filling deadline.
 - A relevant contractor plan room service with a statewide circulation
 - A relevant construction lead generating service with state wide circulation
 - An Internet site sponsored by either a governmental entity or a statewide association that represents the governmental entity.

The notice shall contain the following information:

- a. The time and place for filing sealed bids.
 - b. The time and place sealed bids will be opened and considered on behalf of the City.
 - c. The general nature of the public improvement on which bids are requested.
 - d. In general terms when the work must be commenced and completed.
 - e. That each bidder shall accompany the bid with a bid security as defined in section 26.8 and as specified by the City.
 - f. Any further information, which the City deems pertinent.
2. A public hearing on the proposed plans, specifications, form of contract, and estimated cost has been held in compliance with Chapter 26 of State of Iowa. A notice of the public hearing shall be published in one (1) official designated City newspaper not less than four (4) nor more than twenty (20) days prior to the date of the hearing.
 3. Preparation of contract documents will include preparation of the Notice to Bidders as required by the Code of Iowa. The notice will be furnished to the City Clerk with the preliminary plans and specifications and the City Clerk will arrange for the publication of the notice.
 4. Unsuccessful bidders shall be entitled to the return of bid bonds. A successful bidder shall forfeit any surety required upon failure to enter into a contract within the time span specified.
 5. Disposition of Bids and Bid Bonds:
 - a. Bids shall be opened at the time and place specified in the "Notice of Request for Bids."

- b. A Tabulation of bids received shall be made and shall be available for public inspection.
 - c. A summary of all bids shall be retained in the Financial Services Division.
 - d. One (1) copy of the original offer and award form shall be forwarded to the City Clerk after the opening of the bids.
 - e. The requesting department will consult with the Director of Finance & Business Operations before the final recommendation for award is submitted by the requesting department to the City Council if the project is not included in the budget or capital improvements program or if the bid received is in excess of the budgeted amount.
 - f. The City Council shall award all formal contracts.
 - g. The City Attorney shall review the standard contract to be used. If there are modifications to the standard contract, the City Attorney will review the contract before it is approved by Council.
 - h. The City Council shall approve all performance bonds for construction contracts.
 - i. Following the City Council's award of contract, and approval of the performance bond when required, the requesting department shall award the contract.
 - j. The responsible department shall return bid bonds to unsuccessful bidders following the award of contract by the City Council, and the approval of the performance bond when required.
 - k. The City Clerk shall prepare contract documents when necessary, and shall forward completed contract documents to the successful bidder as awarded by the City Council.
6. If a public improvement is less than the threshold as determined by the State of Iowa (\$~~196439~~,000 1/1/~~2319~~) and more than the threshold as determined by the State of Iowa (\$~~8157~~,000 1/1/~~2319~~), formal bidding procedures are not necessary. However, competitive quotations must be received. When competitive quotations are required the City shall make a good faith effort to obtain quotations for the work from at least two (2) contractors regularly engaged in such work prior to the letting of a contract.
- a. The quotes shall be solicited by the appropriate department.

- b. After quotes are received the department determines the lowest bid.
 - c. The summary of quotes are to be provided to Financial Services where they will be kept on file.
 - d. A contract for the improvement shall than be approved by City Council.
7. If a public improvement falls under the minimum threshold as determined by the State of Iowa (~~\$57,000 1/1/19~~), neither formal bidding procedures nor competitive quotations are necessary.
- a. The department responsible for the project should make an effort to receive a fair and reasonable price for the project.
 - b. If a contract is needed for the project, it shall be approved by the City Council.
8. All public improvements in excess of \$25,000 must have a resolution passed by City Council authorizing the expenditure of funds.

11.03 HIGHWAY, BRIDGE, AND CULVERT (HORIZONTAL INFRASTRUCTURE) BIDDING PROCEDURES:

- 1. If a horizontal infrastructure project is more than the threshold as determined by the State of Iowa (~~\$54,000 1/1/22~~) Iowa Code Section 314.1B establishes horizontal bid thresholds for city projects. These thresholds may adjust each year effective January 1. Formal bidding procedures are required as described in section 11.02.
- 2. If a horizontal infrastructure project is less than the threshold as determined by the State of Iowa (~~\$54,000 1/1/22~~), formal bidding procedures and competitive quotations are not required.
 - a. The department responsible for the project should make an effort to receive a fair and reasonable price for the project.
 - b. If a contract is needed for the project, it shall be approved by the City Council.

Public Improvement Bidding Procedures

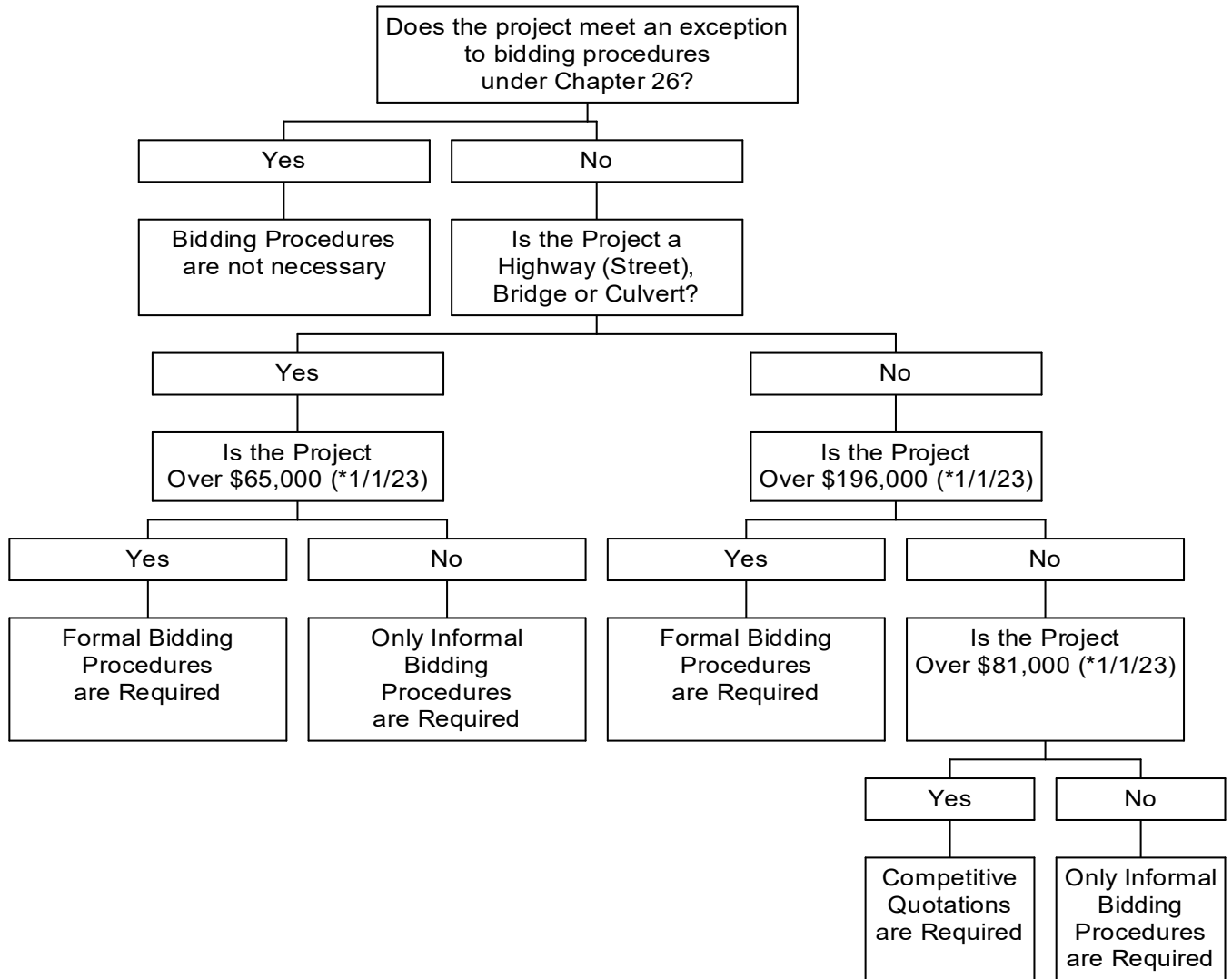

- [Iowa Code Section 314.1B establishes vertical and horizontal bid thresholds for city projects. These thresholds may adjust each year effective January 1. See \[https://iowadot.gov/local_systems/Bid-and-quote-thresholds\]\(https://iowadot.gov/local_systems/Bid-and-quote-thresholds\)](https://iowadot.gov/local_systems/Bid-and-quote-thresholds)

11.04 WRITTEN QUOTATIONS:

Requests for the purchase of equipment, commodities and/or services with an estimated value of \$25,000 or greater shall receive written quotations. All requests in excess of \$25,000 must have a resolution passed by City Council authorizing the expenditure of funds, unless as described in Section 7.04(6) under vehicle purchases that have been programmed as a part of the City's Cash Management Plan. A purchase of equipment, commodities and/or services with a total of less than \$25,000.00 shall be evaluated by the requesting Department Director to determine if the material and/or services requested meet the requirements for requesting quotations.

1. 10-30 days should be allowed from receipt of an approved Requisition and any required specifications to award of purchase.
2. Telephone quotations must be taken by the requesting department on purchases of equipment, commodities, and/or services in excess of \$5,000.00 and less than \$25,000.00.
3. If it is determined to be in the best interest of the City, written quotations will be requested by the using department.
4. Awards of formal or informal bids on the purchase of equipment, commodities, and/or services shall be made by the requesting department director. Award shall be based on the lowest and best bid as determined by the requesting department.
5. The bids and quotations shall be filed with the Financial Services Division.

Purchasing Flow Chart
Equipment, Commodities and/or Services

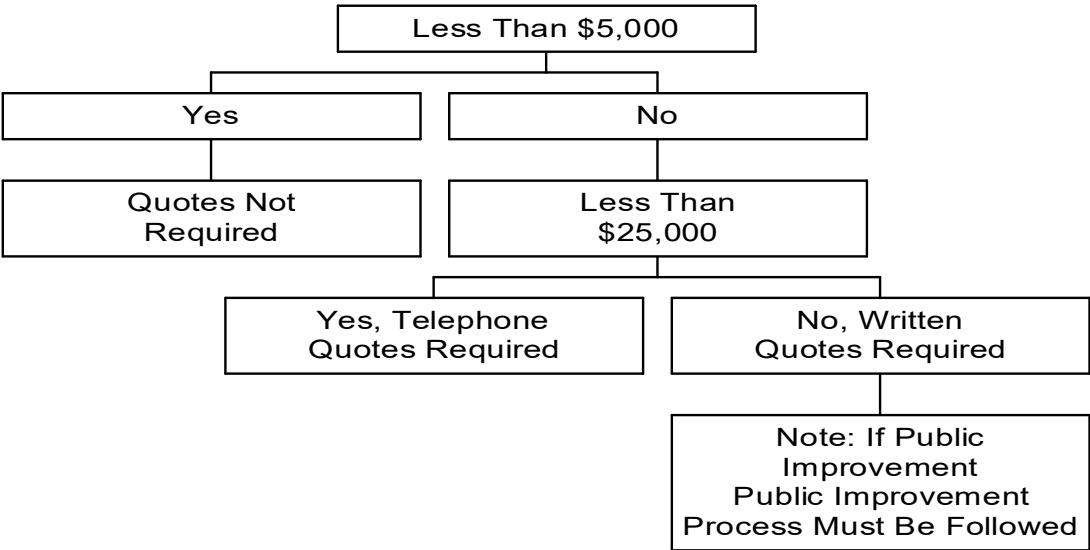

11.05 COMPETITIVE NEGOTIATIONS:

If under \$25,000.00 and if deemed appropriate by the Director of Finance & Business Operations, competitive negotiations may be used rather than competitive sealed bids or quotations. If over \$25,000.00, City Council approval is required prior to commencing competitive negotiations.

1. A Negotiating Team shall be formed consisting of representatives of the Finance & Business Operations Department and the requesting department. Technical advisors may also be included if applicable.
2. Prospective bidders will be supplied with a request for a proposal. This request will state in general terms the materials and/or services to be purchased, and will include the evaluation criteria.
3. The Negotiating Team will review the proposals received and will then negotiate with bidders to procure the materials and/or services required.

11.06 PROFESSIONAL CONSULTANTS:

These procedures will assist in identifying prospective consultants, selecting the most qualified consultant for the project, and developing a consultant contract that will best protect the City's interest. These procedures shall not conflict with federal or state rules or regulations as they relate to professional consultants.

1. The following procedures should be utilized whenever consultant work in excess of \$50,000.00 is required. When consultant work of less than \$50,000.00 is required, procedures (c) through (i) concerning the need to make a consultant selection from among several prospective consultants may be eliminated. Staff may then negotiate a contract with a consultant qualified to perform the work desired. If the consultant work is in excess of \$50,000, however, the work is an extension of an existing or prior project, please see 11.06 2.
 - a. Establish a selection team consisting of appropriate City staff and other City officials as designated. Technical advisors may also be included if applicable. The selection team should be involved in all phases of the selection process.
 - b. Identify in writing the preconceived needs of the City, including a general statement of what City staff perceives the scope of services to be. The City's scope of services may be adjusted after the consultant interviews due to information provided by prospective consultants in the interviews that results in an alteration of the work plan.
 - c. Send out a Request for Proposal to pre-qualified consultants who have been

identified as performing professional services similar to the needs of the City. It will be the responsibility of the selection team to determine who the qualified consultants are. Ideally, requests for qualifications should be sent to three to seven consultants depending on the number of consultants available to perform the type of work desired. The scope of services of the City should be included in the letter sent to prospective consultants. In addition, the letter should include a brief community profile, the contact information for the selection team, and any other information, which may be useful to prospective consultants. In some instances, the request should also contain the information in item (g) below.

- d. The following should be considered in order to obtain a list of at least three consultants from which to send requests for proposals:
 - 1) Always include all the local consultants that appear to have the expertise necessary to perform the desired work.
 - 2) Contact state and national professional consulting associations and other communities who have utilized consultants to perform this type of work in the past.
 - 3) If it is necessary to reduce the list to a manageable size, preference should be given to those consultants which are located in the closest proximity to Cedar Falls along with those firms which the City may know are exceptionally qualified to perform the desired work.
- e. The request for proposal should ask each candidate to submit:
 - 1) A general profile of their firm.
 - 2) The qualifications of the personnel to be used on this project, the projects which the consultant and those individuals have performed of a similar nature, and their availability to perform the desired work within the time frame specified by the City.
- f. The selection team should meet to review the qualifications of the consultants, which submit letters of interest to determine those consultants who appear to be qualified and can meet the City's time frame. Check the past work record of those consultants with entities who have utilized their services in the past to perform similar projects and determine their level of satisfaction with the consultant's work. Based on this review, reduce the list to three or more consultants from which to interview, if that many consultants can demonstrate expertise for furnishing services.
- g. Ask each interviewee to submit, prior to the interview, a preliminary scope of services for the project, the company organization, and the name of the

project coordinator/manager who will be utilized for this project. Request that the project coordinator/manager be present at the interview session. This consultant should also submit information concerning the availability of personnel to be assigned to the project, a typical form of contract that they have used on similar projects, and a sample of a written report, which they have developed on a similar assignment. Set a time for the interview and inform the consultant of the amount of time to be allowed for the consultant's formal presentation.

h. Interview Session:

- 1) The selection team will conduct all interview sessions, which are to be held in private. The selection team should meet prior to conducting the interviews to develop a list of questions to ask the interviewees and to establish weighting criteria to evaluate the consultants. The weighting criteria should include both cost and quality factors such as those identified in h.(2) and (3) below:
- 2) Ask each consultant to make a formal presentation within the predetermined time limit describing their credentials and how they would solve the needs of the City. Consultants should also indicate how they have solved similar assignments for other communities.
- 3) Following the formal presentation, interaction with the interviewee should take place with questions covering the following topics and others which may be appropriate:
 - a) Question the personal credentials if not properly identified during the formal presentation (license to practice, etc.).
 - b) Question the availability of the consultant to perform the work (particularly if their present work load appears to be substantial) and how successful they have been in completing other projects on time. Also ask if the work to be accomplished is with present staff or through additions to the consultant's staff.
 - c) Ask each consultant to define how they see the problem and what they see as the City's goals and objectives in using their consultant's services.
 - d) Ask questions concerning the procedures and methods the consultant proposes to use to solve the problem and attempt to challenge the problem. Also, attempt to challenge the consultant to provide innovations they would use to solve this problem. Also, attempt to obtain the consultant's knowledge of the state-of-the-art technology in this field.

- e) Ask for a budget range, which the consultant expects to expend to conduct this project.
 - f) Ask the consultant about the facilities and equipment they either own or have access to for use on this project, including computer equipment, reproduction and communication equipment, laboratory and testing equipment, and other specialized equipment applicable to this project.
 - g) Ask each consultant if any of his or her professional services for this project are to be subcontracted. Also, ask if any of their services are to be performed as a joint venture with another firm. If the project is receiving federal aid, the consultant shall provide proof of adhering to federal aid guidelines for subcontractors.
 - h) Discuss the typical form of contract used for this service on this type of project or alternative forms of contract.
- i. Selection Process:
- 1) The selection team should meet to evaluate each consultant, utilizing the team's previously established weighting criteria. Conduct phone interviews with references provided by the consultant to determine those entities' satisfaction with the consultant's past performance. In addition, the selection team should attempt to contact other entities that have utilized the consultant other than those entities provided as references by the consultant. If desirable, conduct an on-site examination of the consultant's facilities and equipment to better determine the consultant's ability to perform the assignment.
 - 2) Cedar Falls and Iowa consultants should be given preference if equal proposals are received from more than one consultant, unless prohibited by Federal Law.
 - 3) Make a selection.
- j. Negotiate with the consultant selected as first choice and develop a contract. The following (1) through (6) identify provisions, which should be included in consultant contracts. Examples of these and other contract provisions can be obtained by contacting the City Clerk's Office, which has actual City/consultant contracts on file.
- 1) Agree to the details of each scope of service to be provided including initiation and completion dates for the entire project and major phases of the project as necessary.

- 2) Determine the basis for charges, always including a maximum dollar limit not to be exceeded.
 - 3) Include a provision that the consultant will notify the City in writing if he/she feels that the City is directing the consultant to perform work beyond the scope of services. This notification will include an estimate of the cost, which the consultant proposes for the additional work. Any work to be performed by the consultant beyond the scope of services must be preceded by written authorization from the City requesting such work.
 - 4) If it is anticipated that this contract will result in additional phases of work, negotiate the method of payment to be employed for future contract(s).
 - 5) Include termination provisions in the contract.
 - 6) Include in the contract a provision that the City will assume possession of the final report, documents, and drawings/renditions produced in the course of the project, which are desired by the City.
- k. If the negotiations are unsatisfactory, terminate the negotiations and utilize the procedure outlined in item j) above to negotiate a contract with the interview committee's second choice.
2. If a project is an extension of a current or prior contract, the same consultant may be selected without utilizing the procedures outlined above. Examples of an extension of a contract may include: projects where there are multiple phases and a consultant was selected for an earlier phase, a consultant was selected for a project whose geographical location and project components are contiguous to the upcoming project, or if on a joint private-public project a consultant was selected by the private party and it is cost-effective for the public party to utilize the same consultant. If the consultant work meets these contract extension criteria, staff may negotiate a fair and reasonable price with the consultant.
 3. If a consultant is needed for select studies that are legally confidential, a consultant may be selected by staff after council has directed the staff to proceed with the study.

11.07 SPECIAL EVALUATION CRITERIA:

1. Local Preference
 - a. In cases where two or more bids, formal or informal, are equal in all aspects, preference shall be given to the local (Cedar Falls business) bidder.

- b. In cases where two or more bids, formal or informal, are equal in all aspects, preference shall be given to the Iowa vendor if one of the equal bids is not a Cedar Falls business.
- c. A City department making a purchase request may recommend to the Director of Finance & Business Operations purchase of an item from a Cedar Falls business if it is slightly higher than the lowest bid or quotation and if the item's total cost is within the constraints of the line item budget. The selection of a slightly higher quotation must be supported with written documentation that maintenance, accessibility, or service benefits make the purchase financially advantageous in the long run. This policy should only apply to items, which may be purchased by quotation and does not apply to contract for professional services or construction projects, which require bids or other select processes.

2. Total Cost of Ownership

- a. Life cycle cost formulas shall be used where applicable.
- b. Factors such as service, location and availability, warranty, maintenance records, etc. shall be considered where applicable.

3. Vendor performance records shall be considered where applicable.

4. In Resolution #8170 the City Council of the City of Cedar Falls supported the development of City-wide recycling projects and the effort of area recyclers, and the City also adopted a recycling policy to guide its own actions, which included the use of recyclable and recycled paper products whenever appropriate to the need and available at a reasonable rate.

11.08 CHANGE ORDER POLICY - FORMAL CONTRACTS:

- 1. Field Changes and Unit Changes: this type of change order consists of those items, which are necessary to carry out the intent of the original contract.
 - a. The Department Director or designee serving as "project manager" shall have the authority to approve individual field and unit changes up to \$200,000 and when the combined total of all field and unit changes does not exceed 15% of the original contract, subject to the budget provisions in 11.08(1)(d).
 - b. When an individual field and unit change exceeds \$200,000 or the combined total of all field and unit changes exceeds 15% of the original contract, the "project manager" must submit a Change Order Expansion Request to the Department of Finance & Business Operations for approval of

the City Council. Prior to City Council action the Department of Finance & Business Operations shall determine the potential sources of funding for the change order overage.

- c. It will be the responsibility of the "project manager" to keep a running total of change orders for each contract and ensure individual change orders do not exceed \$200,000 or the combined total of all field and unit changes does not exceed 15% of the original contract.
 - d. Total change orders when totaled with the original contract shall not exceed the projects budgeted appropriations previously approved by the City Council.
2. Scope of Work or Project Boundary Change Orders: This type of change order consists of those items, which are outside the scope of the original contract.
- a. When a "project manager" requests a scope of work or project boundary change they must submit the proposal to the Department of Finance & Business Operations for City Council endorsement.
 - b. The Department of Finance & Business Operations will determine if funds are available in the Capital Projects Fund, operating capital account, or Bond Fund.
 - c. Once financial options are determined the Department of Finance & Business Operations shall submit the change to the City Council for endorsement and amendment of the project budget.

11.09 APPRAISAL CONTRACTS:

- 1. Through the course of purchasing or selling property, the City will need to obtain appraisals to determine the fair and reasonable value of a property.
- 2. The City shall solicit Request for Proposals (RFPs) for appraisal services.
 - a. The requests will be sent to at least three appraisal firms.
 - b. The proposals shall be evaluated by the Departments of Community Development and Finance & Business Operations and a selection made.
- 3. As an alternative, the City may elect to do an annual RFP for appraisal services. The same procedures listed in 11.09 2 shall be utilized and then the firm will have a one-year contract to perform all appraisals for the City during that year. The City may elect, however, at any time during the year to seek new RFPs for select appraisals if advantageous to the City.

11.10 LEASE-PURCHASE AND RENTAL AGREEMENTS:

1. Lease-Purchase:

- a. An agreement that conveys the right to use property, plant or equipment, usually for a stated period of time, that meets one or more of the criteria set forth in SFAS No.13 for lease capitalization. The criteria are:
 - 1) The lease transfers ownership by the end of the lease term.
 - 2) The lease contains a bargain purchase option.
 - 3) The lease term is equal to 75 percent or more of the estimated economic life of the leased property.
 - 4) The present value of the minimum lease payments equal or exceed 90 percent of the fair value of the lease property.
- b. An evaluation shall be made by the department making the purchase to determine if lease-purchase or cash purchase of a piece of equipment is more cost effective.
- c. If a lease-purchase is considered the most cost effective method of obtaining property, the purchase shall be made in accordance with other provisions in this manual and shall be approved by Finance & Business Operations

2. Rental Agreement:

- a. A rental agreement is any lease agreement that does not meet the criteria for capitalization set forth in SFAS No.13 and described in Section 11.09 1a.
- b. An evaluation shall be made by the department making the purchase to determine if rental of equipment or a cash purchase is more cost effective.
- c. Rental agreement for all vehicles or for equipment with a fair market value greater than \$5,000.00 requires prior approval of the Finance & Business Operations Department.

11.11 PAYMENTS AND RETENTION FROM PAYMENTS ON FORMAL CONTRACTS

1. Department's responsibilities:

- a. Process the bills from contractors and withhold 5% of retainage on each contractor payment.
- b. Receive final acceptance of the project from the City Council.

- c. Process the bill that will pay the five percent retainage and notify the Financial Services Division that the payment must be held for thirty days.
- d. Provide to Financial Services the appropriate contractor information prior to the start of the project for registration of sales tax exemption certificates.

2. Financial Services Responsibilities:

- a. Write and deliver the checks making monthly pay estimates to the contractors.
- b. Hold the final payment for thirty days after final acceptance by Council.
- c. Register the project and contractors with the State on-line system at the beginning of the project for sales tax exemption certificates.

3. Early Release of Retainage:

- a. At any time after all or any part of the work on the formal contract is substantially completed, the contractor may request the release of all or part of the retained funds owed. The request by the contractor shall be accompanied by a sworn statement of the contractor that, ten calendar days prior to the filing of the request, notice was given to all known subcontractors, sub-subcontractors, and suppliers.
- b. A project is considered substantially complete if the project has been substantially completed in general accordance with the terms and provisions of contract; if the project is substantially complete so that the City can occupy or utilize the public improvement for its intended purpose; if the public improvement has been designated substantially complete by the architect or engineer on the project; or if the project is considered substantially complete because the City is occupying or utilizing the public improvement for its intended purpose.
- c. After receiving the request, if the contractor has met the requirements noted above, the City must release the retainage within thirty (30) days.
- d. The City does reserve the right to withhold 200% of the value of the uncompleted work as determined by the City.

SECTION 28

OUTSIDE ~~ENTITY~~ AGENCY

FUNDING

28.01 PURPOSE:

1. No direct donations or in-kind contributions to private entities, including to non-profits, is allowed other than for economic development purposes. However, the City may enter into agreements for private entities to provide services to the City or to the public. Nothing in this Section shall be construed to prevent the City from generally supporting private entities, including non-profits, as long as individual private entities are not singled out for support.

28.02 PROCESS

1. On an annual basis, outside ~~entities~~ agencies may apply to the City of Cedar Falls for funding public services agreements or economic development assistance.
2. ~~The F~~ funding for such activities amount will be presented to the City Council for approval through the annual budget process.
3. Funding for outside ~~entities~~ agencies will not be provided for under the General Fund, unless determined to be associated with a City operation funded in the General Fund.

28.0~~3~~ APPLICATION PROCEDURE:

1. The ~~entity~~ agency applying for an agreement or funding should contact Finance & Business Operations to determine the most appropriate process which avenue they should pursue to request funding.
2. The Director of Finance & Business Operations and Controller/City Treasurer along with other applicable staff from other departments will determine the most appropriate process and will inform the private entity of the same whether the agency should apply under the Tourism & Visitors Fund, the Health Trust Fund, Economic Development Fund, Community Betterment Fund, Community Block Grant Fund, or any other special fund.
3. Under special circumstances funding for large community capital projects may occur under the City's Capital Projects Fund or other unique funding sources.
4. Project requests associated with the University of Northern Iowa (UNI) should be directed to Finance & Business Operations from the University's Office of the Vice President of Administration and Finance or the Special Assistant to

the President for Board and Governmental Relations. Usually a 28E Agreement will be necessary for this purpose.

28.043 FUNDING SOURCES:

1. Health Trust Funding - Applications are submitted to the Health Trust Fund Board in October of each year. The Board uses a formula based on the interest income derived off of trust assets to determine the amount of funding available to be distributed. They Board presents its~~their~~ recommended funding model in February to the City Council as part of the annual budget process.
2. Economic Development/~~Community Betterment~~Tourism Activities Funding - Applications are submitted to the Economic Development Committee (City Administrator, Director of Community Development, Director of Finance & Business Operations, Economic Development Coordinator and Visitor & Cultural Programs Manager) in November of each year. The Committee uses a formula based on hotel/motel tax revenue to determine the amount of funding available each year. They Committee presents its~~their~~ recommended funding model in February to the City Council as part of the annual budget process.
3. ~~Tourism Development~~ Funding/Marketing Funds Grant Program~~Community Betterment Funding~~ - Applications are submitted to the Visitors & Tourism Board ~~throughout the in November of each~~ year. The Board uses a formula based on hotel/motel tax ~~funds, revenue along with funds in the Visitors & Tourism budget,~~ to determine the amount of funding available each year. ~~They present their recommended funding model in February to the City Council as part of the annual budget process.~~ The City Council approves the amount of funding as part of the annual budget process and the Visitors & Tourism Board then approves individual agreements with awardees for funding. The Visitor and Tourism/Cultural Programs Manager-City Administrator is authorized to execute such individual agreements as long as the amounts included in such agreements do not exceed the annual budget allocation when considered individually and in total.
4. Community Block Grant Funding - Applications are received by the Planning & Community Services Division each year. The amount of funding is determined by the annual federal appropriation through the Block Grant program. This funding is then presented to the City Council as part of the annual budget process.

Commented [SS1]: Update after V&T Board discussion.

28.05 PUBLIC SERVICES AGREEMENTS WITH PRIVATE ENTITIES:

1. When the City enters into an agreement with a private entity, including a non-profit, to provide services to the public, the following shall be included:
 - a. The agreement shall be in writing, signed by the parties, and include plain, detailed and unambiguous terms and conditions.
 - b. Payment terms shall be clear, including the scheduling of payments.

- c. The services to be provided by the non-profit to the public shall be clearly stated. Overall, consideration shall be balanced for each party and the City shall seek the highest value possible for taxpayers.
- d. In an agreement in which the non-profit is not providing a clear service directly to the City but rather the service is to the public, the public benefit shall serve as the consideration the City receives under the agreement.
- e. The total cost of the agreement shall be stated and required supporting documentation for payment shall be clearly defined.
- f. The agreement shall include a requirement for the private entity to account to the City for the public funds and how they are spent to meet the public services requirement. The form and frequency of the accounting shall be stated in the agreement.
- g. All public service agreements with private entities shall be subject to approval of Council and must be reflected in the Council minutes. The Council Resolution approving the agreement with the private entity, as well as the Council minutes, shall include the public purpose served by the agreement.

28.06 ECONOMIC DEVELOPMENT ASSISTANCE

- 1. Economic development is a public purpose for which the City may provide grants, loans, guarantees, tax incentives, and other financial assistance to or for the benefit of private persons and entities, including non-profits.
- 2. Economic development means private or joint public and private investment involving the creation of new jobs and income or the retention of existing jobs and income that would otherwise be lost.
- 3. Before funds are used for economic development assistance Council shall determine that a public purpose will reasonably be accomplished by the dispensing or use of City funds. In the case of 4b below, the Visitor & Tourism Board has authority to make such determination as part of with the Tourism Development Grant Program.
- 4. In determining whether to approve economic development assistance, the following factors shall be considered:
 - a. Private entities or persons that add diversity to or generate new opportunities for the local economy should be favored over those that do not.
 - b. Economic assistance funds should attract, retain, or expand businesses that produce exports or import substitutes, or which generate tourism-related activities.
 - c. Economic assistance funds should be targeted toward private entities and persons that generate public gains and benefits. The amount of funds to be

disbursed should be compared to the gains and benefits to be generated.

d. Economic assistance funds should not be used to attract a local business to relocate unless the business is considering in good faith to relocate outside the area or unless the relocation is related to an expansion which will generate significant new job creation. Jobs created as a result of displacement of other jobs in similar local businesses shall not be considered significant new job creation.

28.07 FEDERAL AND STATE PROGRAMS

1. Allocations of funding received from federal and state programs shall comply with program requirements and need not take the form of a public services agreement or necessarily be based on economic development.



DEPARTMENT OF COMMUNITY DEVELOPMENT

City of Cedar Falls
 220 Clay Street
 Cedar Falls, Iowa 50613
 Phone: 319-273-8600
 Fax: 319-268-5126
 www.cedarfalls.com

MEMORANDUM

Planning & Community Services Division

TO: Honorable Mayor Robert M. Green and City Council
FROM: Michelle Pezley, AICP, Planner III
DATE: January 17, 2023
SUBJECT: Community Development Block Grant Funds (CDBG) Service Agency
 Contract: Exceptional Persons, Inc

The City of Cedar Falls is committed to obtaining funds every year through federal programs like CDBG, HOME, and Section 8 to help serve the needs of low- and moderate-income families and individuals living in Cedar Falls. The City may use up to 15% of our CDBG to fund local service agencies.

As listed in the Annual Action Plan for this year, the City designated \$38,970 to Prevent Homelessness through Agency and Organizational Support.

Staff has been working with six service agencies that have responded to the Request for Proposals. This is the last contract that staff proposes for the CDBG funds. Attached is the contract with Exceptional Persons, Inc. for \$5,800. The Exceptional Persons proposes to use the funds for rental assistance.

At their September 21, 2022 meeting, the Housing Commission reviewed the recommended allocation of funds to these agencies and recommends approval.

Xc: Stephanie Houk-Sheetz, AICP, Director of Community Development
 Karen Howard, AICP, Planning & Community Services Manager

2/17/2022

CITY OF CEDAR FALLS, IOWA
 GENERAL TERMS AND CONDITIONS
 (PARTIES/SUBJECT OF CONTRACT)

This Agreement is by and between Exceptional Persons, Inc ("Contractor") and the City of Cedar Falls, Iowa ("City"), and is to be effective on the date last signed by the Contractor or the City below.

1.0. Contractor's Services

1.1. Contractor's services shall consist only of the those services and/or products provided or supplied by Contractor as defined in this Agreement and as listed on Exhibit "A" attached. ("Services" or "Scope of Services")

1.2. Contractor shall not commence or perform any work outside the Scope of Services unless and until authorized in writing by the City. No changes to the Scope of Services shall be valid unless agreed to by both the Contractor and the City in writing. Any work performed or expenses incurred by the Contractor shall be conclusively presumed to be part of the Scope of Services unless a written change order covering such work, and the cost of such work, has been agreed to in advance. If Exhibit "A" includes provisions for contingent services, such services shall not be performed until written authorization is given by the City.

1.3. Contractor shall assign qualified and experienced personnel to perform the Services, and Contractor hereby warrants to the City that Contractor has sufficient experience and financial resources to complete the Services required by this Agreement. Where the Scope of Services identifies particular personnel who shall perform the Services, such personnel shall remain assigned to provide the Services throughout the term of this Agreement, unless otherwise approved in writing by the City. In the event that such particular personnel must be replaced, Contractor agrees to replace such particular personnel with persons of equivalent or better qualifications, as approved by the City.

1.4. Contractor shall perform the Services in a timely manner and in accordance with any schedule set forth in Exhibit "A". The Contractor and the City agree that time is of the essence with respect to Contractor's performance under this Agreement.

1.5. Contractor warrants that its fulfillment of this Agreement will not infringe on or misappropriate the rights of any third party, and that the Contractor has the complete right and full authority to convey ownership of the Services to the City. Contractor shall obtain all required governmental and third-party licenses, approvals and permits for the provision of Services, at Contractor's cost.

1.6. The person signing this Agreement on behalf of the Contractor represents and warrants that the person has full and sufficient authority to execute this Agreement on behalf of the Contractor.

2.0. Compensation

2.1. All bids and prices shall be shown in U.S. Dollars. All prices must remain firm for the duration of this Agreement.

2.2. After inspection (if applicable) and acceptance by the City of Services, City shall pay Contractor in accordance with the payment terms set forth in Exhibit "B". The maximum amount of all payments for Services shall be the amount set forth in Exhibit "B", unless additional Services are agreed upon as set forth in Section 1.2, in which case the maximum amount of all payments shall be adjusted accordingly.

2.3. Following acceptance of Services by the City, payment shall be made to the Contractor within thirty (30) days of receipt of a proper invoice. The invoice shall include, at a minimum. The name and address of the Contractor, the invoice number, the date services were performed or goods were shipped, a general description of the services or

2/17/2022

goods, total amount to be paid, any discounts or credits, and the net amount to be paid. The invoice shall be mailed or emailed to the authorized representative of the City listed below, at the address listed below.

2.4. Expenses shall not be reimbursed to the Contractor unless specifically described in Exhibit "B".

2.5. If services in addition to the Scope of Services are agreed upon as set forth in Section 1.2, Contractor must provide a separate invoice for such additional services before payment will be made.

K2.6. Notwithstanding anything to the contrary in this Agreement, the City may withhold payment to Contractor for faulty Services, or if the City is advised of liens or other claims against any Services, including products.

3.0. Taxes.

3.1. The City is exempt from all federal, State of Iowa, and other states' taxes on the purchase of products and services used by the City within the State of Iowa. The City shall provide tax exemption certification as required.

3.2. Any charges for taxes from which the City is exempt will be deducted from invoices before payment is made.

4.0. Ownership and Use of Documents

4.1. All Services to be provided under this Agreement, and any invention, improvement, discovery, or innovation (whether or not patentable) made, conceived or actually reduced to practice by Contractor in the performance of the Scope of Services in this Agreement will be owned exclusively by the City, including all proprietary and intellectual property rights. To the extent not automatically vested in the City, Contractor hereby assigns to the City all right, title and interest in and to the Services, including, without limitation, copyright, patent and trade secret rights. Upon the City's request, Contractor shall execute any additional documents necessary for the City to perfect such ownership rights.

4.2. Notwithstanding Section 4.1, Contractor retains ownership of its pre-existing and proprietary materials and other intellectual property that may be incorporated into the Services.

4.3. Copies of City furnished data that may be relied upon by Contractor are limited to the printed copies (also known as hard copies) that are delivered to the Contractor. Files in electronic media format of text, data, graphics, or of other formats that are furnished by the City to the Contractor are only for the convenience of the Contractor. Any conclusion or information obtained or derived from such electronic files will be at the Contractor's sole risk.

4.4. During the term of this Agreement and following completion or termination of the Agreement, the Contractor and any authorized Subcontractors shall maintain all accounting records and other documentation generated in providing Services under this Agreement. The City or its designee shall be allowed to have access to such information for the purpose of inspection, audit and copying during normal business hours for a period of five (5) years after the final payment by the City, termination of this Agreement, or resolution of all matters under this Agreement, whichever date is latest. No additional compensation shall be paid to Contractor for such retention or inspection by the City or designee.

5.0. Term and Termination.

5.1. The term of this Agreement shall commence on the effective date and end on June 30, 2022 unless earlier terminated under the terms of this Agreement.

5.2. The City may terminate this Agreement at any time for its convenience by giving written notice to the Contractor of such termination and specifying the effective date of the termination, at least thirty (30) calendar days before the effective date of termination. In that event, all finished or unfinished Services, reports and materials prepared or furnished by the Contractor shall, at the option of the City, become the City's property. If the Agreement is terminated by the City as provided herein, the Contractor shall be paid for all Services which have been authorized, approved and provided up to the effective date of termination. The City will not be subject to any termination fees from the Contractor.

2/17/2022

5.3. Either party may terminate this Agreement upon seven (7) calendar days written notice in the event that the other party fails to substantially perform in accordance with the terms of this Agreement through no fault of the party initiating the termination.

6.0. Warranties.

6.1. Contractor represents and warrants that Services shall be performed in a manner consistent with the standard of care of other professional service providers in a similar industry and application.

6.2. Contractor represents and warrants that products delivered as part of the Scope of Services, including each component, shall be free of defects and shall conform to the quality standards of the applicable industry and shall meet in all respects the requirements of the Scope of Services. If any defect or sign of deterioration is identified by the City within one year after delivery which is not due to the acts or omissions of the City, Contractor shall, within 15 days after notification by the City, at Contractor's expense, repair, adjust or replace such items to the complete satisfaction of the City.

6.3. Contractor shall be responsible for the quality, technical accuracy, completeness and coordination of all Services under this Agreement. Contractor shall promptly and without charge, provide all corrective work necessary as a result of Contractor's acts, errors or omissions with respect to the quality and accuracy of Contractor's Services.

6.4. Contractor shall be responsible for any and all damages to property or persons as a result of Contractor's acts, errors or omissions in performing the Services under this Agreement, and for any losses or costs to repair or remedy any Services undertaken by the City as a result of any such acts, errors or omissions.

6.5. Contractor's obligations shall exist without regard to, and shall not be construed to be waived by, the availability or unavailability of any insurance, either by the City or by the Contractor. None of the provisions of this Agreement shall be construed as a limitation on the City's right to seek recovery of damages it suffers as a result of Contractor's fault or breach.

7.0. Warranties – Intellectual Property.

7.1. Contractor represents and warrants that the Services produced or provided to the City do not infringe upon any copyright, trademark, trade name, trade dress patent, statutory, common law or any other right of any person or entity.

7.2. Contractor represents and warrants that the Services, and the City's use of the same, and the exercise by the City of the rights granted by this Agreement, shall not infringe upon any other work or violate the rights of publicity or privacy of, or constitute a libel or slander against, any person or entity.

7.3. Contractor represents and warrants that it is the owner of or otherwise has the right to use and distribute the Services contemplated by this Agreement.

8.0. Disputes.

8.1. Should any dispute arise with respect to this Agreement, the parties agree to act immediately to resolve such dispute. Time is of the essence in the resolution of disputes.

8.2. Contractor agrees that, the existence of a dispute notwithstanding, it will continue without delay to carry out all of its responsibilities under this Agreement that are not affected by the dispute and the City shall continue to make payment for all Services that are performed in conformance with this Agreement. Should the Contractor fail to continue to perform its responsibilities regarding all non-disputed Services, without delay, any additional costs incurred by the City or the Contractor as a result of such failure to proceed shall be borne by the Contractor.

8.3. Should any dispute between the parties remain unresolved, the parties mutually agree to engage in mediation prior to the filing of suit by either party. The cost of mediation shall be divided equally between the parties

2/17/2022

except that each party shall be responsible for that party's own expenses and attorney fees associated with mediation. The City shall not engage in arbitration of any dispute.

9.0. Indemnification and Hold Harmless.

9.1. To the fullest extent permitted by law, Contractor (for purposes of this Section 9.0, includes employees, subcontractors, agents and others working on behalf of Contractor under this Agreement) agrees to defend (for all non-professional claims), indemnify, and hold harmless the City (for purposes of this Section 9.0 includes elected and appointed officials, employees, and agents working on behalf of the City) against any and all claims, demands, suits or loss, including any and all outlay and expense connected therewith, and for damages, which may be asserted, claimed or recovered against or from the City, including, but not limited to, damages arising by reason of personal injury, including bodily injury or death, and property damage, which arises out of or is in any way connected or associated with the work and/or services provided by the Contractor to the City under this Agreement, to the extent caused by or arising out of the errors, omissions, negligent or intentional acts of the Contractor.

9.2. Contractor's duty of indemnification and to hold harmless includes, but is not limited to, Contractor's breach or alleged breach of the warranties found in Sections 6.0 and 7.0 above, and shall survive the termination of this Agreement. Such duty also includes damage, loss or injury to the City or City property.

9.3. Contractor expressly assumes full responsibility for loss, expense, damages or injuries which may result to the Contractor by reason of or in connection with the work and/or services provided by Contractor under this Agreement to the extent caused by or arising out of the errors, omissions, negligent or intentional acts of the Contractor.

9.4. It is specifically agreed between the parties that this Agreement is not intended to create in the public or any member of the public third party beneficiary status or to authorize anyone not a party to this Agreement to maintain a suit for personal injuries or property damage.

10.0. Insurance.

Contractor shall at all times during the performance of this Agreement maintain insurance as set forth in Exhibit unless this insurance requirement is waived by the City in this Section.

Insurance requirement waived: Risk Management Committee approval 11/3/22 (Signature and title of authorized City employee or officer)

SA Hill 11/9/23.

The City may at any time during the term of this Agreement require proof of such insurance.

11.0. Compliance with Laws and Regulations.

11.1. Contractor certifies that in performing this Agreement it will comply with all applicable provisions of federal, state and local laws, ordinances, rules, licenses and regulations and shall make reasonable efforts to ensure that its employees, agents, subcontractors and others working on behalf of the Contractor under this Agreement do the same.

11.2. Contractor is responsible for determining which products are considered to be hazardous chemicals under applicable standards and to provide the most current Safety Data Sheet ("SDS") with the initial shipment of such chemicals. Failure by Contractor to do so may be considered by the City to be delivery of a defective product and its delivery may be refused. It is also the Contractor's responsibility to provide to the City any updated or revised SDS as it becomes available for any such hazardous chemicals sold and delivered to the City.

12.0. Independent Contractor.

Both parties shall act in their individual capacities in the performance of this Agreement and not as agents, employees, partners, joint ventures or associates of one another. The employees or agents of one party shall not be deemed or construed to be the employees or agents of the other for any purpose whatsoever.

2/17/2022

13.0. Non-Collusion.

13.1. Neither the Contractor, nor anyone acting on behalf of Contractor, has employed any person to solicit or procure this Agreement, nor will the Contractor make any payment or agreement for payment of any compensation in connection with the solicitation or procurement of this Agreement.

13.2. Contractor agrees that there is no agreement, arrangement or understanding expressed or implied, contemplating any division of compensation for Services provided under this Agreement, or in the participation in such Services, directly or indirectly, by any person or entity, except as provided in this Agreement.

13.3. Neither the Contractor, nor anyone acting on behalf of Contractor, has either directly or indirectly entered into any agreement, arrangement or understanding to collude or otherwise take any action in restraint of free competitive procurement in connection with this Agreement.

14.0. Nondiscrimination and Equal Opportunity.

14.1. Contractor will not discriminate against any employee or applicant for employment because of race, sex, color, creed, national origin, marital or familial status, religion, age, disability, sexual orientation, gender identity, genetic information or veteran status, or any other classification protected by federal, state, or local law, except where age or sex is an essential bona fide occupational requirement, or where disability is a bona fide occupational disqualification.

14.2. Contractor shall inform all subcontractors and agents performing under this Agreement of this nondiscrimination and equal opportunity requirement and shall take reasonable steps to ensure their compliance with the same.

15.0. No Conflict of Interest.

Contractor represents, warrants and covenants that no relationship exists or will exist during the term of this Agreement that is a conflict of interest under Iowa law. No employee, officer or agent of the Contractor shall participate in the procurement or performance of this Agreement if a conflict of interest exists as to such person. Should a conflict of interest arise during the term of this Agreement for Contractor or any employee, officer or agent of Contractor, Contractor shall immediately notify the City, in which case this Agreement may be terminated and any excess costs incurred by the City due to such termination shall be paid by Contractor or deducted from any sums yet due to Contractor.

16.0. Force Majeure.

16.1. Force majeure shall be any of the following events: acts of God or the public enemy; compliance with any order, rule, regulation, decree, or request of any governmental authority or agency or person purporting to act as such; acts of war, public disorder, rebellion, terrorism, or sabotage; floods, hurricanes, or other storms; strikes or labor disputes; or any other cause, whether or not of the class or kind specifically named or referred to in this Agreement which is not within the reasonable control of the party affected. A delay in or failure of performance by either party shall not constitute a default in performance nor be the basis for, or give rise to, any claim for damages, if and to the extent such delay or failure is caused by force majeure.

16.2. The party who is prevented from performing by force majeure shall be obligated, within a period not to exceed fourteen (14) calendar days after the occurrence or detection of any such event, to provide notice to the other party setting forth in reasonable detail the nature thereof and the anticipated extent of the delay, and shall remedy such cause as soon as reasonably possible, as mutually agreed between the parties.

16.3. If a remedy to an event of force majeure cannot be agreed upon within a reasonable amount of time, this Agreement may be terminated by either party.

2/17/2022

17.0. Assignment.

No rights under this Agreement may be assigned or transferred by Contractor without the prior written consent of the City. The benefits of this Agreement may inure to Contractor's assigns, transferees, or successors in interest if approved by the City in writing in advance, and if such assignee, transferees or successors agree in writing to be bound by the terms of this Agreement.

18.0. Governing Law.

18.1. This Agreement shall be governed, interpreted and enforced in accordance with the laws of the State of Iowa, regardless of choice of law principles.

18.2. Venue for any dispute under this Agreement shall be the District Court in and for Black Hawk County, Iowa.

19.0. Discrepancy.

In the event that there are any discrepancies or differences between any terms or conditions of the Contractor's bid or quote and this Agreement, this Agreement shall prevail, even if the Contractor's bid or quote is incorporated into this Agreement.

20.0 Public Record.

20.1. This Agreement as well as Contractor's bid or quote and all documents submitted with any such bid or quote shall become public documents subject to Iowa Code Chapter 22, the Iowa Open Records Law. By submitting the bid or quote or any document to the City in connection with such bid or quote, the submitting party recognizes this and waives any claim against the City, its elected and appointed officers, and its employees, and agents working on behalf of the City, relating to the release of any bid or document submitted.

20.2. Each submitting party shall hold the City and its elected and appointed officers, and its employees, and agents working on behalf of the City, harmless from any claims arising from the release of any document or information made available to the City related to or arising from the bidding or quoting process.

20.3. Notwithstanding Sections 20.1 and 20.2, protection from disclosure may apply to those elements of any submittal that may be a trade secret, or confidential or proprietary information. Should the submitting party wish to designate submittals as such, they must be clearly and prominently marked. The City shall make no determination as to whether or not such documents are protected from disclosure under Iowa Code Chapter 22. Rather, the City shall endeavor to notify the submitter of any request for such information and the submitter shall be solely responsible for asserting exemption from disclosure by obtaining a court order. As long as the City makes a good faith effort to notify the submitter of a request for such information, the City and the City's elected and appointed officers, the City's employees, and agents working on behalf of the City, shall not be liable for any damages resulting from such disclosure, whether such disclosure is deemed required by law, by an order of court or administrative agency, or occurs through inadvertence, mistake, or negligence.

21.0. Debarment.

21.1. Contractor hereby certifies, pursuant to 48 CFR Part 9, that neither it nor its principals are presently debarred, suspended, proposed for debarment, declared ineligible, or voluntarily excluded from participation in this Agreement by any federal agency.

21.2. Contractor further certifies that it is not presently debarred, suspended, proposed for debarment, declared ineligible, or voluntarily excluded from participation in any contracts with the City or with the State of Iowa.

2/17/2022

22.0 Confidentiality of Shared Information.

No information shared between Contractor and the City in the performance of this Agreement shall be deemed confidential unless clearly designated as such in writing by the party seeking confidentiality at the time of sharing. If designated as confidential the parties agree to maintain the confidentiality of such information except as necessary for performance under this Agreement, unless or until written authorization for disclosure is given by the designating party, or as required by law, or by an order of a court or administrative agency. In the event of a dispute over the confidentiality of shared information, the parties agree to maintain the confidentiality of the designated information until the issue of confidentiality is resolved. The duty to maintain the confidentiality of such information shall survive the termination of this Agreement.

23.0. Entire Agreement.

23.1. This Agreement, and Exhibits, which are incorporated into this Agreement by this reference, contains the entire agreement and understanding by and between the parties with respect to the subject matter, and no representations, promises, agreements, or understandings, written or verbal, not contained in this Agreement, shall be of any force or effect.

23.2. No change, modification or waiver of this Agreement shall be valid or binding unless the same is in writing and signed by the party against whom such change, modification or waiver is sought to be enforced.

24.0. Additional Terms.

24.1 On-site monitoring visits may be conducted by the City at City's discretion to verify Agreement compliance.

24.2 The City will review Contractor files to determine if adequate information is being maintained to be in compliance with Exhibit B of this Agreement. The City will provide the Contractor with a monitoring report outlining any deficiencies in record keeping procedures and any corrective action to be implemented after any on-site monitoring visit.

24.3 See Exhibit C – Federal Contract Requirements

24.4 See Exhibit D – Quarterly Report Template

25.0. Notices.

Any notice required to be given under this Agreement and any authorization required to be provided shall be given or provided to:

City:

Name: Michelle Pezley
Title: Planner III
Address: 220 Clay St
Cedar Falls, IA 50613
Telephone: 319.268.5194
Email: michellepezley@cedarfalls.com

Contractor:

Name: James Perry
Title: CFO
Address: 760 Ansborough Ave
Waterloo IA 50704
Telephone: 319-433-7697
Email: James.Perry@epi-service.org

2/17/2022

In Witness Whereof, the City and the Contractor have caused this Agreement to be executed as of the last date listed below.

CONTRACTOR

Exceptional Persons Inc.

By: James Perry CFO
Its: [Signature]

Date: 11/8/2022

CITY OF CEDAR FALLS, IOWA

By: _____

Robert M. Green, Mayor

Attest: _____

Jacqueline Danielsen, MMC, City Clerk

Date: _____

Program Budget

July 1, 2022 – June 30, 2023

Income		Expense	
CDBG Award	\$5,800	1 mo. Rent Assistance – 3 people	\$1,500
		3 mo. Rent Assistance – 5 persons in daily site	\$4,300
Total Income	\$5,800	Total Expense	\$5,800

Exhibit C
Federal Contract Requirements

1. RECORDS AND AUDITS

The Contractor shall maintain accounts and records, including personnel, property and financial records, adequate to identify and account for all costs pertaining to the Contract and such other records as may be deemed necessary by the City to assure proper accounting for all project funds, both Federal and nonfederal shares. These records will be made available for audit purposes to the City or any authorized representative and will be retained for three years after the expiration of this Contract unless permission to destroy them is granted by the City.

2. FINDINGS CONFIDENTIAL

All of the reports, information, data, etc., prepared or assembled by the Contractor under this Contract are confidential and the Contractor agrees that they shall not be made available to any individual or organization without the prior written approval of the City.

3. COPYRIGHT

No report, maps or other documents produced in whole or in part under this Contract shall be the subject of an application for copyright by or on behalf of the Contractor.

4. COMPLIANCE WITH LOCAL LAWS

The Contractor shall comply with all applicable laws, ordinances and codes of the State of Iowa and the City of Cedar Falls, and the Contractor shall save the City harmless with respect to any damages arising from any tort done in performing any of the work embraced by this Contract.

5. EQUAL OPPORTUNITY EMPLOYMENT

During the performance of this Contract, the Contractor agrees as follows:

1. The Contractor will not discriminate against any employee or applicant for employment because of age, race, creed, sex, sexual orientation, gender identity, religion, color, disability, or national origin. The Contractor will take affirmative action to ensure that applicants are employed, and that employees are treated equally during employment, without regard to their age, race, creed, sex, sexual orientation, gender identity, religion, color, disability, or national origin. Such action shall include, but not be limited to, the following: Employment, upgrading, demotion, or transfer; recruitment or recruitment advertising; layoff or termination; rates of pay or other forms of compensation; and selection for training, including apprenticeship. The Contractor agrees to post in conspicuous places, available to employees and applicants for employment, notices to be provided by the City setting forth the provisions of this non-discrimination clause.
2. The Contractor will, in all solicitation or advertisements for employees placed by or on behalf of the Contractor, state that all qualified applicants will receive consideration for employment without regard to age, race, creed, sex, sexual orientation, gender identity, religion, color, disability, or national origin.
3. The Contractor will, cause the foregoing provisions to be inserted in all subcontracts for any work covered by this Contract so that such provisions will be binding upon each subcontractor, provided that the foregoing provisions shall not apply to contracts or subcontracts for standard commercial supplies or raw materials.
4. The Contractor will comply with all provisions of Executive Order 11246 of September 24, 1965, and of the rules, regulations and relevant orders of the Secretary of Labor.
5. The Contractor will furnish all information and reports required by Executive Order 11246 of September 24, 1965, and by the rules, regulations and orders of the Secretary of Labor, or pursuant thereto, and will permit access to his books, records and accounts by the City's Department of Community Development and the Secretary of Labor for purposes of investigation to ascertain compliance with such rules, regulations and orders.
6. In the event of the Contractor's noncompliance with the noncompliance clauses of this Agreement or with any of such rules, regulations or orders, this Agreement may be canceled, terminated or suspended in whole or in part and the Contractor may be declared ineligible for further Government contracts in accordance with procedures authorized in Executive Order 11246 of September 24, 1965, and such other sanctions may be imposed and remedies invoked as provided in Executive Order 11246 of September 24, 1965, or by rule, regulation or order of the Secretary of Labor, or as otherwise provided by law.
7. The Contractor will include the provisions of paragraphs 11(1) through 11(7) in every subcontract or purchase

order unless exempted by rules, regulations or orders of the Secretary of Labor issued pursuant to Section 204 of Executive 11246 of September 24, 1965, so that such provisions will be binding upon each subcontractor or vendor. The Contractor will take such action with respect to any subcontract or purchase order as the City's Department of Community Development may direct as a means of enforcing such provisions including sanctions for noncompliance: Provided, however, that in the event the Contractor becomes involved in, or is threatened with, litigation with a subcontractor or vendor as a result of such direction by the City's Department of Community Development, the Contractor may request the United States to enter into such litigation to protect the interests of the United States.

8. CIVIL RIGHTS ACTS OF 1964

Under Title VI of the Civil Rights Act of 1964, no person shall, on the grounds of race, color or national origin, be excluded from participation in, be denied the benefits of, or be subjected to discrimination under any program or activity receiving Federal financial assistance.

9. SECTION 309 OF THE HOUSING AND COMMUNITY DEVELOPMENT ACT OF 1974

No person in the United States shall on the grounds of race, color, national origin, or sex be excluded from participation in, be denied the benefits of, or be subjected to discrimination under any program or activity funded in whole or in part with funds made available under this title.

10. "SECTION 3" COMPLIANCE IN THE PROVISION OF TRAINING, EMPLOYMENT AND BUSINESS OPPORTUNITIES

1. The work to be performed under this contract is on a project assisted under a program providing direct Federal financial assistance from the Department of Housing and Urban Development and is subject to the requirements of Section 3 of the Housing and Urban Development Act of 1968, as amended, 12 U.S.C. 1701u. Section 3 requires that to the greatest extent feasible opportunities for training and employment be given lower income residents of the project area and contracts for work in connection with the project be awarded to business concerns which are located in, or owned in substantial part by persons residing in the area of the project.
2. The parties to this contract will comply with the provisions of said Section 3 and the regulations issued pursuant thereto by the Secretary of Housing and Urban Development set forth in 24 CFR 135 and all applicable rules and orders of the Department issued thereunder prior the execution of this contract. The parties to this contract certify and agree that they are under no contractual or other disability which would prevent them from complying with these requirements.
3. The contractor will send to each labor organization or representative of workers with which he has a collective bargaining agreement or other contract or understanding, if any, a notice advising the said labor organization or workers' representative of his commitments under this Section 3 clause and shall post copies of the notice in conspicuous places available to employees and applicants for employment or training.
4. The contractor will include this Section 3 clause in every subcontract for work in connection with the project and will, at the direction of the applicant for or recipient of Federal financial assistance, take appropriate action pursuant to the subcontract upon a finding that the subcontractor is in violation of regulations issued by the Secretary of Housing and Urban Development, 24 CFR Part 135. The contractor will not subcontract with any subcontractor where it has notice or knowledge that the latter has been found in violation of regulations under 24 CFR Part 135 and will not let any subcontract unless the subcontractor has first provided it with a preliminary statement of ability to comply with the requirements of these regulations.
5. Compliance with the provisions of Section 3, the regulations set forth in 24 CFR Part 135, and all applicable rules and orders of the Department issued hereunder prior to the execution of the contract, shall be a condition of Federal financial assistance provided to the project, binding upon the applicant or recipient for such assistance, its successors and assigns. Failure to fulfill these requirements shall subject the applicant or recipient, its contractors and subcontractors, its successors and assigns to those sanctions specified by the grant or loan agreement or contract through which Federal assistance is provided, and to such sanctions as are specified by 24 CFR Part 135.

6. INTEREST OF MEMBERS OF A CITY

No member of the governing body of the City and no other officer, employee, or agent of the City who exercises any functions or responsibilities in connection with the planning and carrying out of the program, shall have any personal financial interest, direct or indirect, in this Contract; and the Contractor shall take appropriate steps to assure compliance.

7. INTEREST OF OTHER LOCAL PUBLIC OFFICIALS

No member of the governing body of the locality and no other public official of such locality, who exercises any functions or responsibilities in connection with the planning and carrying out of the program, shall have any personal financial interest, direct or indirect, in this Contract; and the Contractor shall take appropriate steps to assure compliance.

8. INTEREST OF CONTRACTOR AND EMPLOYEES

The Contractor covenants that they presently have no interest and shall not acquire interest, direct or indirect, in the study area or any parcels therein or any other interest which would conflict in any manner or degree with the performance of their services hereunder. The Contractor further covenants that in the performance of this Contract, no person having any such interest shall be employed.

9. AFFIRMATIVE ACTION STEPS

The Contractor agrees to implement the following specific affirmative action steps directed at increasing the utilization of lower income residents and businesses within the Waterloo-Cedar Falls SMA.

- A. To ascertain from the locality's CDBG program official the exact boundaries of the Section 3 covered project area and where advantageous, seek the assistance of local officials in preparing and implementing the affirmative action plan.
- B. To attempt to recruit from within the necessary number of lower income residents through: Local advertising media, signs placed at the proposed site for the project, and community organizations and public or private institutions operating within or serving the project area such as Service Employment and Redevelopment (SER), Opportunities Industrialization Center (OIC), Urban League, Concentrated Employment Program, Hometown Plan, or U.S. Employment Service.
- C. To maintain a list of all lower income area residents who have applied either on their own or on referral from any source, and to employ such persons, if otherwise eligible and if a vacancy exists.
- D. * To insert this Section 3 plan in all bid documents, and to require all bidders on subcontractors to submit a Section 3 affirmative action plan including utilization goals and the specific steps planned to accomplish these goals.
- E. * To ensure that subcontractors which are typically let on a negotiated rather than a bid basis in areas other than Section 3 covered project areas, are also let on a negotiated basis, whenever feasible, when let in a Section 3 covered project area.
- F. To formally contact union, subcontractors and trade associations to secure their cooperation for this program.
- G. To ensure that all appropriate project area business concerns are notified of pending subcontractual opportunities.
- H. To maintain records, including copies of correspondence, memoranda, etc., which document that all of the above affirmative action steps have been taken.
- I. To appoint or recruit an executive official of the company or Contractor as an Equal Opportunity Officer to coordinate the implementation of the Section 3 plan.
- J. To list all projected work force needs for all phases of this project by occupation, trade, skill level, and number of positions.

**Loans, grants, contracts and subsidies for less than \$10,000 will be exempt.*

**U.S. DEPARTMENT OF HOUSING AND URBAN DEVELOPMENT
CERTIFICATION OF CONTRACTOR REGARDING EQUAL EMPLOYMENT OPPORTUNITY INSTRUCTIONS**

This certification is required pursuant of Executive Order 11246(30 F.R. 12319-25). The implementing rules and regulations provide that any bidder or prospective contractor, or any of their proposed subcontractors, shall state as an initial part of the bid or negotiations of the contract whether it has participated in any previous contract or subcontract subject to the Equal Opportunity clause; and if so, whether it has filed all compliance reports due under applicable instructions.

Where the certification indicates that the Contractor has not filed a compliance report due under applicable instructions, such Contractor shall be required to submit a compliance report within seven calendar days after bid opening. No contract shall be awarded unless such report is submitted.

CERTIFICATION BY CONTRACTOR

NAME AND ADDRESS OF CONTRACTOR: _____

- 1. Contractor has participated in a previous contract or subcontract subject to the Equal Opportunity clause.
 Yes No

- 2. Compliance reports were required to be filed in connection with such contract or subcontract.
 Yes No

- 3. Contractor has filed all compliance reports due under applicable instructions, including SF-100.
 Yes No

- 4. Have you ever been or are you being considered for sanction due to violation of Executive Order 11246, as amended?
 Yes No

PRINTED NAME: _____

TITLE: _____

SIGNATURE: _____

DATE: _____

Exhibit Q
Quarterly Report Template

**CITY OF CEDAR FALLS, IOWA
FY 22-23 CDBG SUB-RECIPIENT
QUARTERLY PERFORMANCE REPORT
DIRECT BENEFIT TO LOW INCOME PERSONS**

AGENCY NAME: _____

QUARTER #: _____

NUMBER OF FEMALE-HEADED HOUSEHOLDS: _____

TOTAL NUMBER OF PERSONS BENEFITTING FROM ACTIVITY: _____

TOTAL NUMBER OF HOUSEHOLDS BENEFITTING FROM ACTIVITY: _____

	<u>Households</u>	<u># Hispanic</u>	<u>Persons</u>	<u># Hispanic</u>
White	_____	_____	_____	_____
Black/African American	_____	_____	_____	_____
Asian	_____	_____	_____	_____
American Indian/Alaskan	_____	_____	_____	_____
Hawaiian/Pacific Islander	_____	_____	_____	_____
American Indian/Alaskan & White	_____	_____	_____	_____
Asian & White	_____	_____	_____	_____
Black/African American & White	_____	_____	_____	_____
American Indian/Alaskan & Black/African American	_____	_____	_____	_____
Other Multi-Racial	_____	_____	_____	_____
TOTAL	_____	_____	_____	_____

Exhibit C
Quarterly Report Template

*This refers to ethnicity rather than race; the number in this column should also be included in the column for total served. A client must identify their race, and then indicate Hispanic or non-Hispanic.

TOTAL NUMBER OF PERSONS SERVED:	<u>Households</u>	<u>Persons</u>
# of Extremely Low Income: (at or below 30% of Area Median Income)		
# of Very Low Income: (between 31 - 50% of Area Median Income)		
# of Low Income: (between 51 - 80% of Area Median Income)		

CDBG Annual Income Limits Effective June 15, 2022								
	1	2	3	4	5	6	7	8
Extremely Low Income	\$17,400	\$19,900	\$22,400	\$24,850	\$26,850	\$28,850	\$30,850	\$32,850
Very Low Income	\$29,050	\$33,200	\$37,350	\$41,450	\$44,800	\$48,100	\$51,400	\$54,750
Low Income	\$46,450	\$53,050	\$59,700	\$66,300	\$71,650	\$76,950	\$82,250	\$87,550

NARRATIVE DESCRIPTION OF QUARTERLY ACTIVITIES USING CDBG FUNDS:

Exhibit C
Quarterly Report Template

LINE ITEM EXPENSES FOR REIMBURSEMENT:

--

AGENCY: _____

ADDRESS: _____

SUBMITTED BY: _____

TITLE: _____

DATE: _____

TELEPHONE: _____

AMOUNT REQUESTING: _____

QUARTER NO: _____



DEPARTMENT OF COMMUNITY DEVELOPMENT

City of Cedar Falls
 220 Clay Street
 Cedar Falls, Iowa 50613
 Phone: 319-273-8606
 Fax: 319-273-8610
 www.cedarfalls.com

MEMORANDUM

Planning & Community Services Division

TO: Honorable Mayor Robert M. Green and City Council
FROM: Michelle Pezley, AICP, Planner III
 Matthew Tolan, EI, Civil Engineer II
DATE: January 17, 2023
SUBJECT: FP22-004 Wild Horse Sixth Addition Final Plat

REQUEST: Request to approve the Wild Horse Ridge Sixth Addition Final Plat. Case #FP22-004

PETITIONER: Midwest Development Co., Owner; CGA Engineering, Engineer

LOCATION: The property is located south of W. 12th Street and west of Union Road

PROPOSAL

The petitioner owns a 21.77-acre parcel that is south of W. 12th Street, west of Union Road, and with access from Granite Ridge Road. The petitioner proposes to subdivide 9.35 acres of the 21.77 acres into 22 residential lots.

BACKGROUND

The City rezoned the entire 148-acre property from A-1, Agriculture to RP, Planned Residential for a maximum of 353 dwelling units in 2005. A Preliminary Plat for this area, called "Copperstone" was approved in July 2005. This plat covered the entire 148-acre property and proposed the establishment of 242 building lots with 353 units. The Final Plat for the Wild Horse Ridge First Addition was approved in September 2007. After several alterations to the preliminary plat, in 2021, City approved the latest alteration to the Preliminary Plat of Wild Horse Ridge, which increased the density of the development from 2.43 to 2.72 units per acre for the Fifth – Tenth additions by adding 40 duplex lots. The duplex lots are proposed to be within the Eighth and Ninth additions. Wild Horse Ridge 5th Addition was approved on August 15, 2022.

ANALYSIS

The petitioner, Midwest Development Co., proposes the final plat of the Sixth Addition, comprised of 9.35 acres of land within the middle of the subdivision, which continues Wild Horse Ridge northwest to connect to Sonoma Drive and Pebble Stone Place. The property is zoned RP Planned Residential. The RP zoning district permits a variety of residential uses from single-family to multi-family dwellings based on a master plan approved at the time of rezoning, which in this case was revised and approved in May of 2021. The revision provided additional density by adding 40 lots for bi-attached or duplex units.

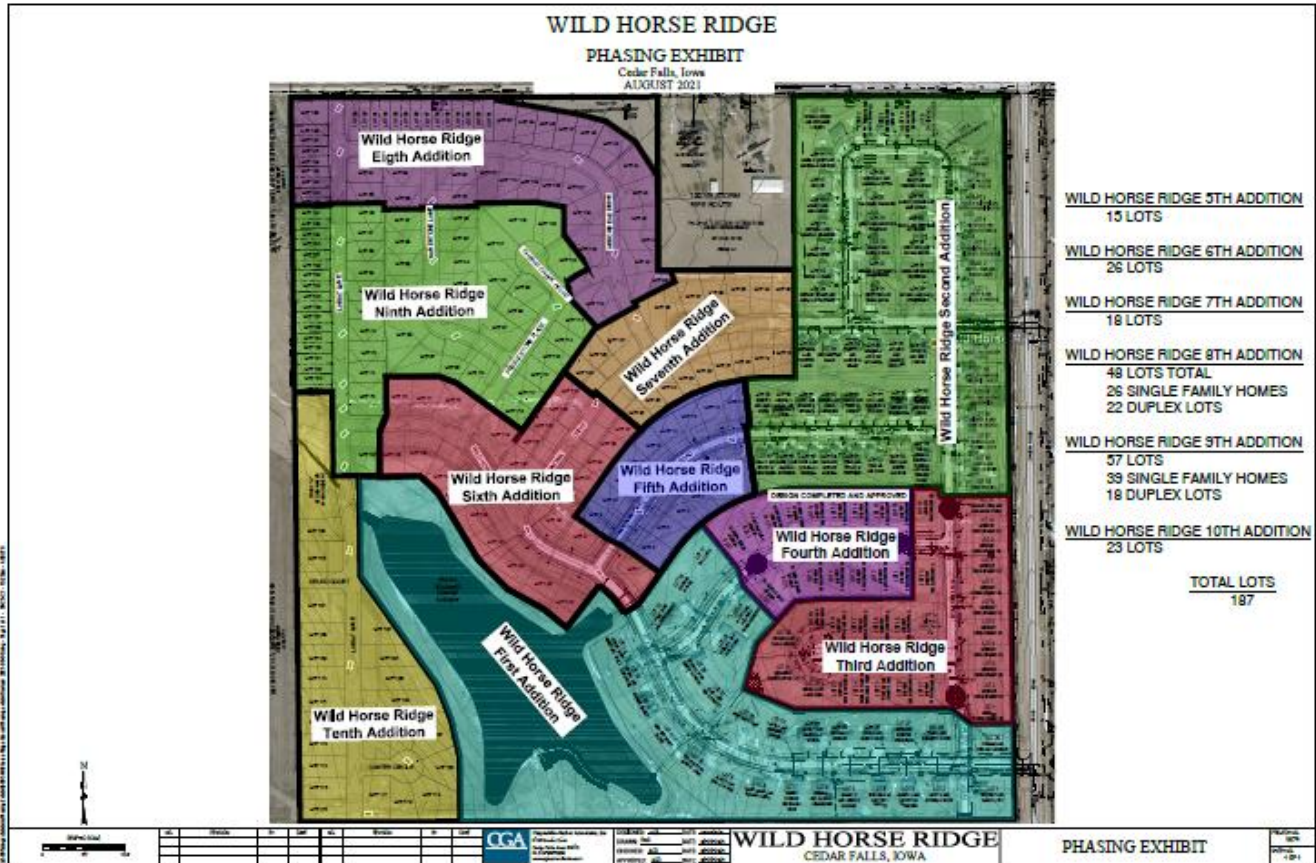

The revision of May 2021 proposed the sixth addition to consists of 26 lots, including the connection between Wild Horse Drive and Granite Ridge Road. Four of the lots originally intended to be part of the Sixth Addition were added to the Fifth Addition at the intersection of Granite Ridge Road and Wild Horse Ridge that was approved by Council on August 15, 2022.

The petitioner will connect to the existing stormwater detention that is part of the Wild Horse Ridge First Addition. Stormwater will flow to the detention pond in the First Addition through an easement. The development agreement also calls for upgrading the stormwater pipes to a larger size in this area with the City reimbursing the developer for the oversize cost. The proposed detention basin will address both the water quantity and water quality of stormwater runoff. In summary, the proposed design of the stormwater management facilities for Wild Horse Ridge Sixth Addition meets the City’s ordinance standards.

The Master Plan calls for 25-foot front setback, 30- foot rear setback and a five-foot side yard setback. The setbacks shown on the face of the plat are consistent with the proposed setbacks from the approved Master Plat and Preliminary Plat and conform to the RP Zoning District requirements.

The submitted Deed of Dedication for this final plat is consistent with the approved Deed of Dedication from the previous addition and has addressed all the necessary requirements.

The City’s maintenance and repair agreement with the owner/developer will address maintenance responsibilities for the public improvements in the subdivision to ensure proper functioning over time.

FINAL PLAT WILD HORSE RIDGE SIXTH ADDITION CEDAR FALLS, IOWA

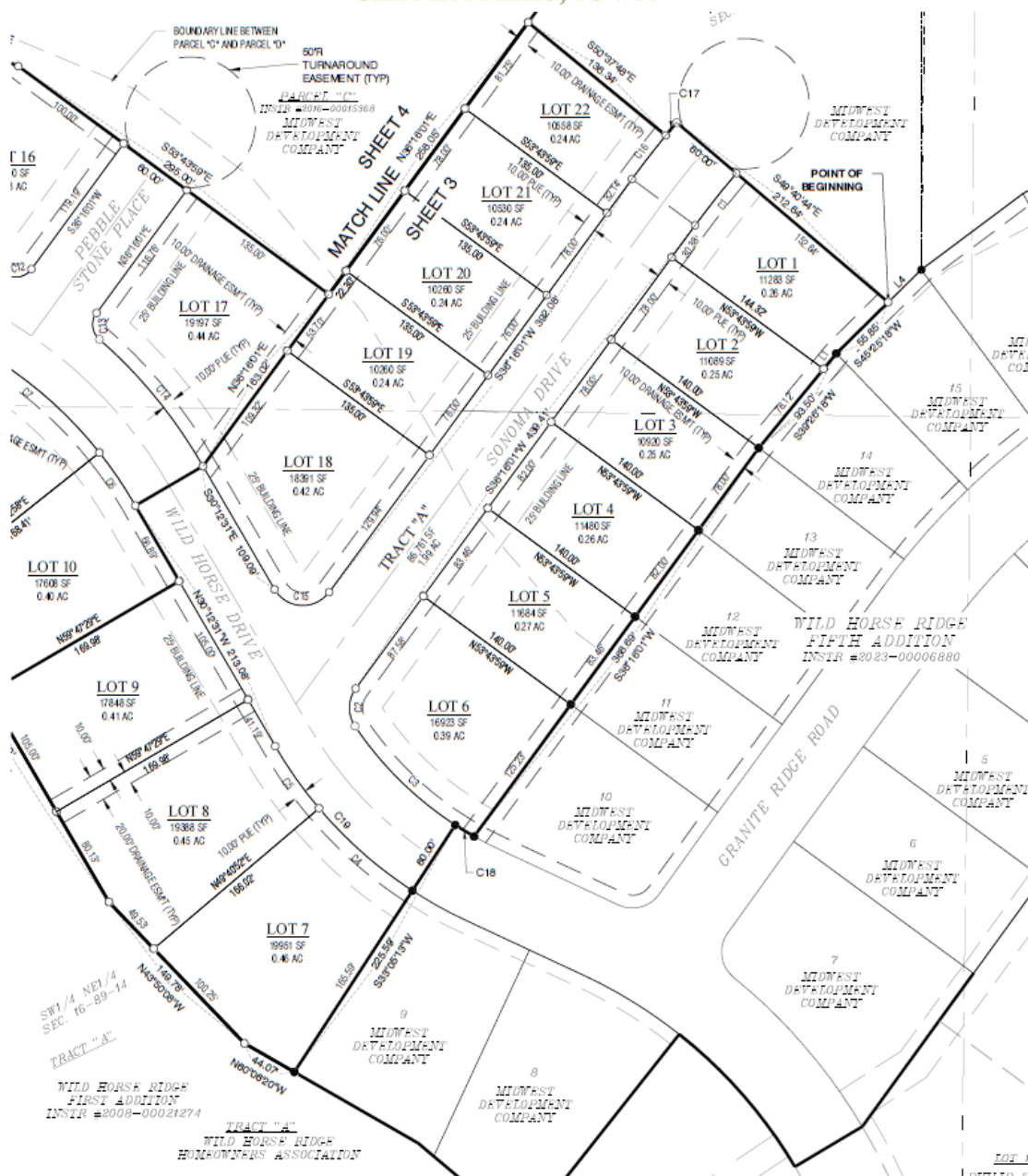

The City Code states that the final plat must be in substantial conformance with the preliminary plat. The number of lots from the preliminary plat has been reduced as mentioned above. The final plat meets the density, lot size, or configuration of the preliminary plat. Therefore, the Planning and Zoning Commission finds that the proposed final plat is conforming with the preliminary plat and associated conditions. The petitioner has met that criterion and the associated conditions.

TECHNICAL COMMENTS

City technical staff, including Cedar Falls Utilities (CFU) personnel, noted that the water, gas, and communication services are available to the site. The developer extended the utility services to the proposed development. The easements identified on the plat satisfy Public Works and CFU requirements.

Cluster mailboxes will be sized and placed in the ROW according to USPS standards. All cluster mailboxes will be located on lower volume streets and situated to prevent undue traffic congestion according to the direction from the City Engineer's office.

The submitted Deed of Dedication for this final plat is consistent with the previously approved Deeds of Dedication from the previous additions and has addressed all the necessary requirements.

In 2014, the City and the developer agreed to share the cost W 12th Street improvements. This fee is calculated at \$5,852.43 per acre of development. The fee of \$5,852.43 x 9.35 acres is \$54,720.22. The fee was paid on October 20, 2022.

All the utilities and internal road connections within the proposed subdivision will be dedicated to the public. The installed internal infrastructure is able to serve the platted lots with access to public streets and right-of-way. The installed utilities are available for development for the platted lots. The petitioner's engineer has submitted a stormwater management plan to the City and it has been reviewed by the City Engineer. The City Engineer has determined that the plan meets the City's subdivision requirements. The Engineering Division is awaiting either final completion of public improvements or will enter into a 'Contract for Completion' with the Developer before proceeding with Council Approval.

City Code requires that sidewalks be installed along all streets within the subdivision. The petitioner has confirmed that sidewalks, built to City standards, will be constructed along the frontage of all lots at the time of lot development, as per City requirements.

The property is located outside of the regulated floodplain.

A courtesy mailing was sent to the neighboring property owners on November 2, 2022.

PLANNING & ZONING COMMISSION RECOMMENDATION

The Planning & Zoning Commission reviewed the final plat for Wild Horse Ridge Sixth Addition (FP22-004) and recommends approval with the following stipulations:

- 1) Any comments or direction specified by the Planning & Zoning Commission.
- 2) Conformance to all city staff recommendations and technical requirements.

PLANNING AND ZONING

Discussion 11/22/22	The first item of business was a final plat for Wild Horse Ridge Sixth Addition. Acting Chair Hartley introduced the item and Mr. Atodaria provided background information. He explained that the subdivision is off of West 12 th Street and Union Road and was originally known as Copperstone. Twenty-two single-family lots are proposed with street connections to Sonoma Drive and Pebble Stone Place. Stormwater management has moved into the existing detention pond and through easements on the rear of each lot. Staff is working with the developer minor changes in the drawings and recommends approval with any comments or direction from the Planning and Zoning Commission.
------------------------	---

Phil Kenealy, 4414 Blair Ridge Road, spoke on behalf of the neighborhood regarding the plat not including playgrounds for the growing number of families with children in the area. He noted that the closest park is two miles away from their neighborhood. They would like to see greenspace for the children in the area.

Acting Chair Hartley asked about greenspace requirements in subdivisions. Mr. Weintraut stated that this subdivision was preliminary platted before the current subdivision code requirement of dedication a portion of the development to park space.

Mr. Kenealy asked if there had been public comments made in 2021 when the preliminary plat was discussed. Mr. Atodaria explained that he can look into that.

Mr. Larson asked if there were any changes from the preliminary plat to the final plat. Mr. Weintraut stated that there were no changes. Ms. Crisman stated that the idea of adding parks is a good idea to discuss in future projects.

Mr. Larson made a motion to approve the item. Ms. Crisman seconded the motion. The motion was approved unanimously with 5 ayes (Crisman, Grybovych, Hartley, Larson and Moser), and 0 nays.

Attachments:

Location Map

Wild Horse Ridge Sixth Addition Final Plat

Deed of Dedication

Public Comment from Phil Kenealy dated November 18, 2022; re: parks

Cedar Falls Planning and Zoning Commission November 22, 2022

Item 13.

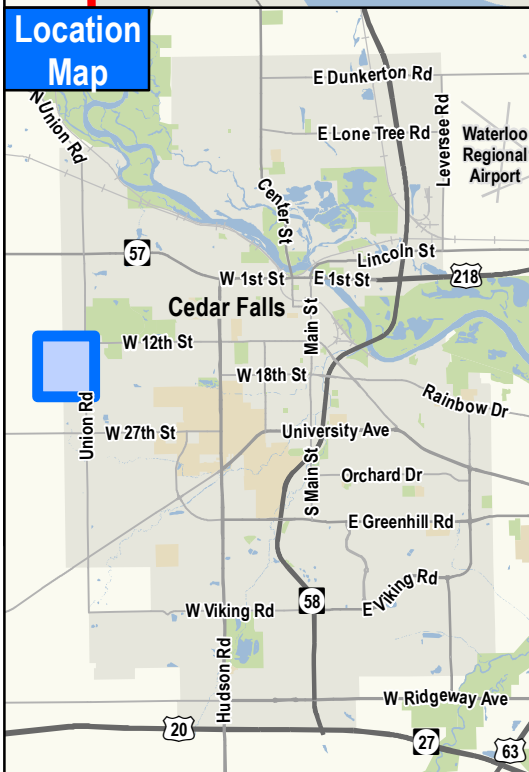
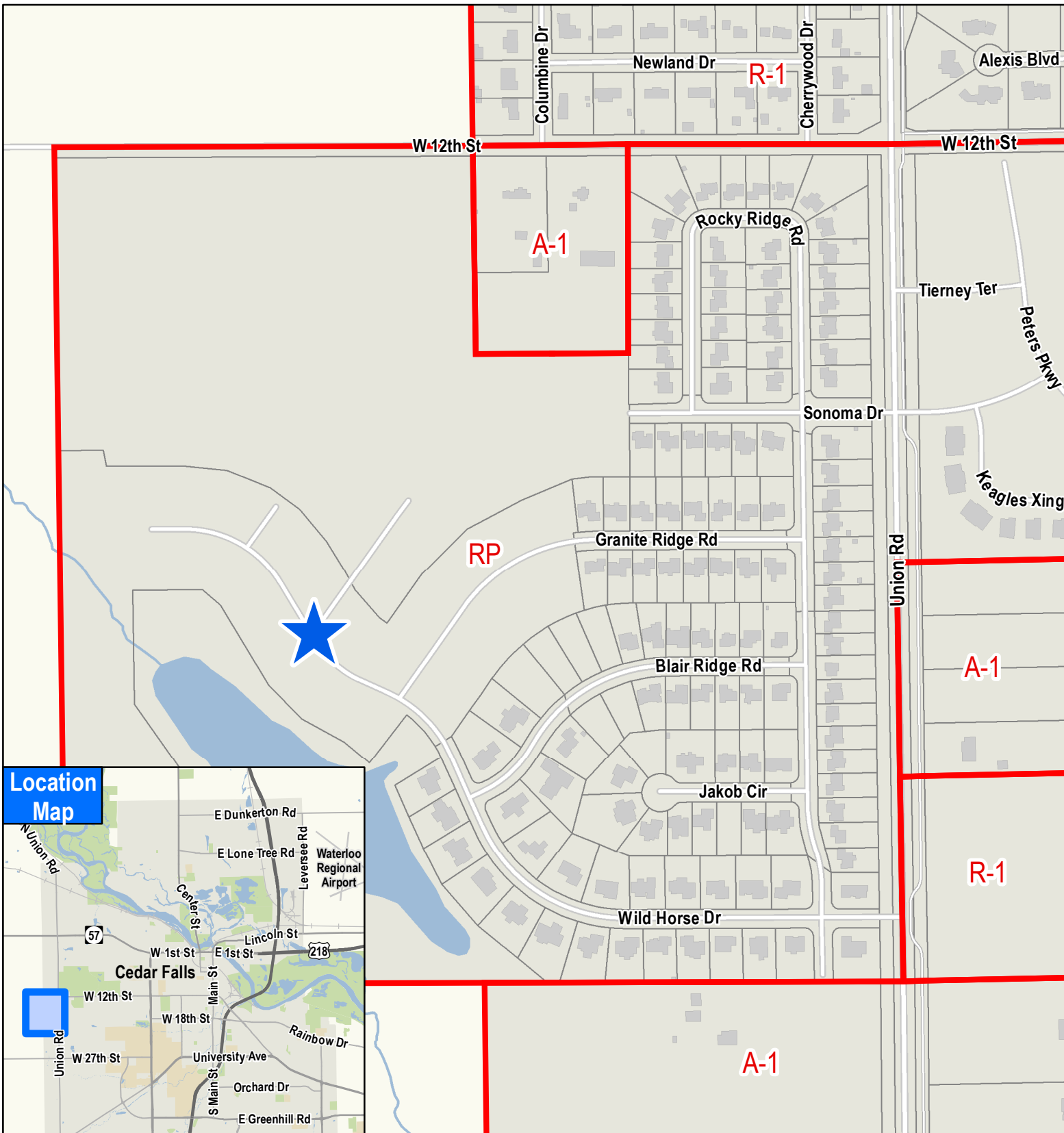

**Final Plat for Wild Horse Ridge
6th addition (FP22-004)
South of W.12th St. and West of Union Rd.**

FINAL PLAT

WILD HORSE RIDGE SIXTH ADDITION

CEDAR FALLS, BLACK HAWK COUNTY, IOWA

JULY 2022

SURVEYOR AND ENGINEER

TRAVIS R. STEWART, P.L.S.
 ADAM DATERS, P.E.
 CLAPSADDLE-GARBER ASSOCIATES
 P.O. BOX 754 - 16 E. MAIN STREET
 MARSHALLTOWN, IOWA 50158
 (641)752-6701

ZONING INFORMATION:

RP (UNLESS NOTED OTHERWISE)

TYPICAL BUILDING SETBACKS

FRONT YARD = 25 FT
 REAR YARD = 30 FT
 SIDE YARD = 5 FT

SURVEY REQUESTED BY:

MIDWEST DEVELOPMENT CO.
 411 FIRST AVENUE SE
 CEDAR RAPIDS, IOWA

CLOSURE:

- ALL SUBDIVISION BOUNDARIES ARE WITHIN THE 1:10,000 ERROR OF CLOSURE REQUIREMENT
- ALL LOTS ARE WITHIN THE 1:5000 ERROR OF CLOSURE REQUIREMENT.

TRACT SUMMARY:

TRACT A - ROAD RIGHT-OF-WAY

SHEET INDEX

SHEET 1	TITLE SHEET
SHEET 2	OVERALL LAYOUT
SHEET 3	FINAL PLAT
SHEET 4	FINAL PLAT

OWNERS OF RECORD

MIDWEST DEVELOPMENT CO.
 411 FIRST AVENUE SE
 CEDAR RAPIDS, IOWA

FLOOD ZONE

(ZONE X)
 PANEL #19013C0145F
 AND
 PANEL #19013C0163F
 EFFECTIVE DATE: JULY 18, 2011

PREPARED DATE:

JULY 5, 2022

BENCH MARK

ELEV = 975.45
 AERIAL SERVICE GPS CONTROL MONUMENT #93 ON THE WEST SIDE OF UNION ROAD, APPROX 277 FEET NORTH OF WILD HORSE DRIVE & UNION ROAD INTERSECTION.

NOTE:

BEARINGS ARE BASED ON THE EAST LINE OF THE NORTHEAST 1/4 OF SECTION 16, TOWNSHIP 89 NORTH, RANGE 14 WEST OF THE FIFTH PRINCIPAL MERIDIAN BEARING NORTH 00°00'09" WEST

AREA:

9.35 ACRES

MAILBOX NOTES:

ALL MAILBOXES SHALL MEET USPS STANDARDS. CONTRACTOR SHALL COORDINATE WITH CITY OF CEDAR FALLS PRIOR TO INSTALLATION.

LOT TABLE

LOT	ACRES	SQ FT
1	0.26	11,283
2	0.25	11,089
3	0.25	10,920
4	0.26	11,480
5	0.27	11,684
6	0.39	16,923
7	0.46	19,951
8	0.45	19,388
9	0.41	17,848
10	0.40	17,608
11	0.41	17,661
12	0.39	17,185
13	0.33	14,400
14	0.29	12,658
15	0.34	14,947
16	0.38	16,710
17	0.44	19,197
18	0.42	18,391
19	0.24	10,260
20	0.24	10,260
21	0.24	10,530
22	0.24	10,558
TRACT "A"	1.99	86,761

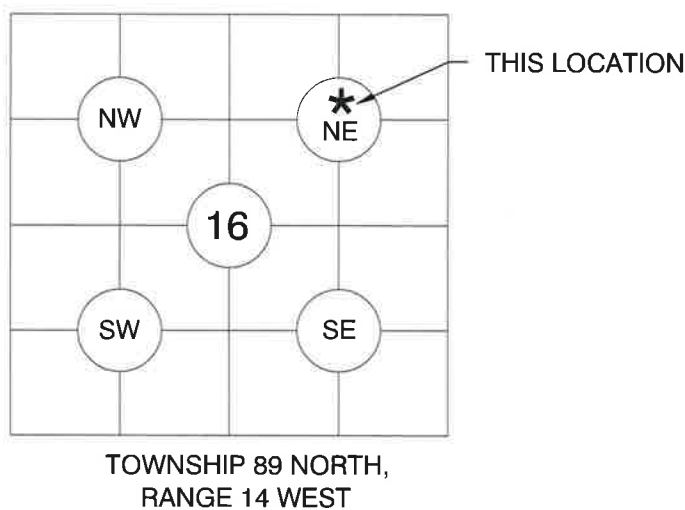

	(GROSS-ACRES)	(EASE-ACRES)	(NET-ACRES)
NW1/4 NE1/4 SEC 16-89-14	4.48 AC	1.06 AC	3.42 AC
SW1/4 NE1/4 SEC 16-89-14	4.88 AC	0.93 AC	3.95 AC
TOTAL	9.36 AC	1.99 AC	7.37 AC

LEGEND:

- ▲ GOVERNMENT CORNER MONUMENT FOUND
- △ GOVERNMENT CORNER MONUMENT SET 1/2" x 30" REBAR w/ORANGE PLASTIC ID CAP #17162
- PARCEL OR LOT CORNER MONUMENT FOUND W/ORANGE PLASTIC ID CAP #17162 UNLESS OTHERWISE NOTED
- SET 1/2" x 30" REBAR w/ORANGE PLASTIC ID CAP #17162
- () RECORDED AS

FINAL PLAT
WILD HORSE RIDGE
SIXTH ADDITION



I hereby certify that this land surveying document was prepared and the related survey work was performed by me or under my direct personal supervision and that I am a duly Licensed Professional Land Surveyor under the laws of the State of Iowa.

Travis R. Stewart 12/21/2022
 Travis R. Stewart, PLS date
 Iowa License Number 17162

My License Renewal Date is December 31, 2023
 Pages or sheets covered by this seal: _____
 SHEETS 1 OF 4, 2 OF 4, 3 OF 4 AND 4 OF 4



Clapsaddle-Garber Associates, Inc
 16 East Main Street
 Marshalltown, Iowa 50158
 Ph 641-752-6701
 www.cgaconsultants.com

DRAWN	SHEET NO.
CAQ	1 OF 4
DATE	PROJECT NO.
7-5-2022	5805.05

FINAL PLAT WILD HORSE RIDGE SIXTH ADDITION CEDAR FALLS, IOWA

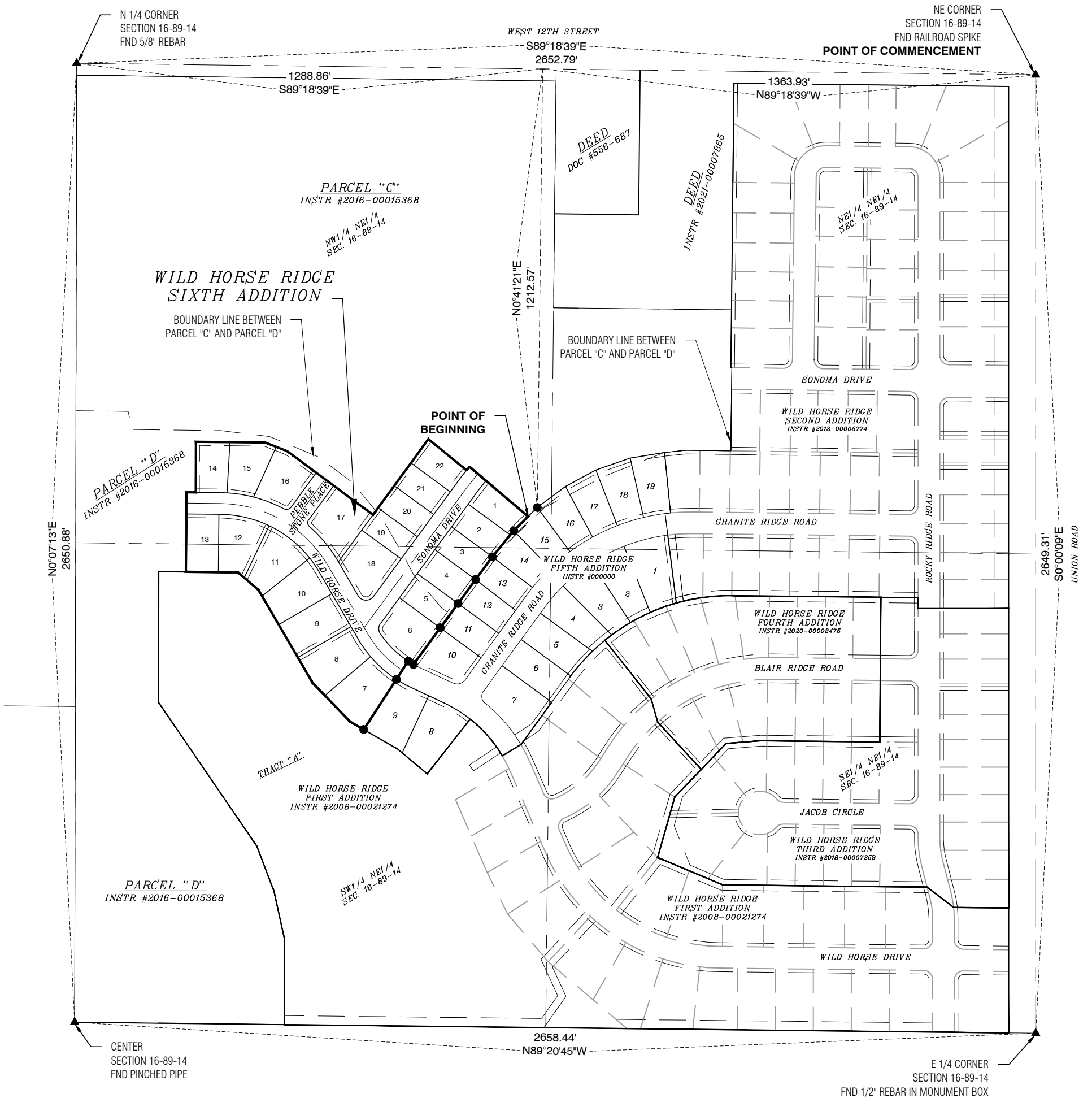

DESCRIPTION

A CERTAIN PARCEL OF LAND LOCATED IN PART OF PARCEL "C" AND IN PART OF PARCEL "D" OF A PLAT OF SURVEY FILED ON DOCUMENT NO. 2016-00015368 IN THE OFFICE OF THE RECORDER, BLACK HAWK COUNTY AND BEING PART OF THE NORTHWEST 1/4 OF THE NORTHEAST 1/4 AND THE SOUTHWEST 1/4 OF THE NORTHEAST 1/4 IN SECTION 16, TOWNSHIP 89 NORTH, RANGE 14 WEST OF THE 5TH P.M., IN THE CITY OF CEDAR FALLS, BLACK HAWK COUNTY, IOWA.

MORE PARTICULARLY DESCRIBED AS FOLLOWS: COMMENCING AT THE NORTHEAST CORNER SECTION 16, TOWNSHIP 89 NORTH, RANGE 14 WEST OF THE 5TH P.M.; THENCE, N89°18'39"W 1363.93' ALONG THE NORTH LINE OF NORTHEAST 1/4 OF SAID SECTION 16; THENCE, S0°41'21"W 1212.57' TO THE NORTHWESTERLY CORNER OF LOT 15 OF WILD HORSE RIDGE FIFTH ADDITION, RECORDED ON DOCUMENT NO. 2023-00006880 IN THE OFFICE OF THE RECORDER, BLACK HAWK COUNTY; THENCE, S45°25'18"W 35.57' ALONG THE NORTHWESTERLY LINE OF SAID LOT 15, SAID POINT ALSO BEING THE POINT OF BEGINNING; THENCE, S45°25'18"W 55.85' ALONG THE NORTHWESTERLY LINE OF SAID LOT 15 TO THE NORTHWESTERLY CORNER OF LOT 14 OF SAID WILD HORSE RIDGE FIFTH ADDITION; THENCE, S39°26'18"W 93.50' ALONG THE NORTHWESTERLY LINE OF SAID LOT 14 TO THE NORTHWESTERLY CORNER OF LOT 13 OF SAID WILD HORSE RIDGE FIFTH ADDITION; THENCE, S36°16'01"W 368.69' ALONG THE NORTHWESTERLY LINE OF LOTS 13, 12, 11 AND 10 OF SAID WILD HORSE RIDGE FIFTH ADDITION TO THE SOUTHWESTERLY CORNER OF LOT 10 OF SAID WILD HORSE RIDGE FIFTH ADDITION, SAID POINT ALSO BEING ON THE NORTHERLY RIGHT OF WAY LINE OF WILD HORSE DRIVE; THENCE, NORTHWESTERLY 16.95' ALONG A 270.00' RADIUS CURVE, CONCAVE NORTHEASTERLY HAVING A CHORD BEARING N58°42'40"W AND A CHORD DISTANCE OF 16.94' ALONG THE NORTHERLY RIGHT OF WAY LINE OF SAID WILD HORSE DRIVE; THENCE, S33°05'13"W 225.59' ALONG A WESTERLY LINE OF SAID WILD HORSE RIDGE FIFTH ADDITION TO THE SOUTHWEST CORNER OF LOT 9 OF SAID WILD HORSE RIDGE FIFTH ADDITION, SAID POINT ALSO BEING ON THE NORTHEASTERLY LINE OF TRACT "A" OF WILD HORSE RIDGE FIRST ADDITION AS RECORDED IN INSTRUMENT NO. 2008-00021274 IN THE OFFICE OF THE RECORDER, BLACK HAWK COUNTY, IOWA; THENCE, N60°06'20"W 44.07' ALONG SAID NORTHEASTERLY LINE; THENCE, N43°50'08"W 149.78'; THENCE, N30°12'30"W 295.00'; THENCE, N48°53'51"W 75.07'; THENCE, N89°21'04"W 145.14'. THE AFORESAID ALL BEING ALONG SAID NORTHEASTERLY LINE OF TRACT "A"; THENCE, N0°39'15"E 220.00'; THENCE, S89°20'45"E 25.17'; THENCE, N0°07'18"E 140.00'; THENCE, S89°20'56"E 191.39'; THENCE, S68°37'20"E 65.82'; THENCE, S53°43'59"E 295.00'; THENCE, N36°16'01"E 258.05'; THENCE, S50°37'48"E 136.34'; THENCE, NORTHEASTERLY 12.95' ALONG THE ARC OF A 780.00' RADIUS CURVE, CONCAVE SOUTHEASTERLY, HAVING A CHORD BEARING OF N39°50'43"E AND A CHORD DISTANCE OF 12.95'; THENCE, S49°40'44"E 212.64' TO THE POINT OF BEGINNING, CONTAINING 9.36 ACRES INCLUDING 1.99 ACRES OF ROAD RIGHT OF WAY. SUBJECT TO EASEMENTS AND RESTRICTIONS OF RECORD, IF ANY.

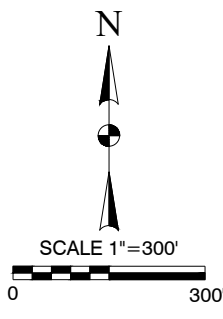

Clapsaddle-Garber Associates, Inc.
16 East Main Street
Marshalltown, Iowa 50158
Ph 641-752-6701
www.cgaconsultants.com

DRAWN CAQ	SHEET NO. 2 OF 4
DATE 7-5-2022	PROJECT NO. 5805.05

FINAL PLAT WILD HORSE RIDGE SIXTH ADDITION CEDAR FALLS, IOWA



Curve Table

CURVE DATA	ARC LENGTH	RADIUS	DELTA ANGLE	CHORD BEARING	CHORD
C1	50.95'	720.00'	4°03'15"	S38°17'38"W	50.94'
C2	30.61'	25.00'	70°09'44"	S1°11'09"W	28.74'
C3	125.41'	270.00'	26°36'50"	S47°12'08"E	124.29'
C4	95.58'	330.00'	16°35'39"	S48°36'58"E	95.24'
C5	58.23'	330.00'	10°06'37"	S35°15'50"E	58.16'
C6	48.99'	321.82'	8°43'17"	N34°04'52"W	48.94'
C7	144.60'	320.00'	25°53'27"	N51°23'45"W	143.37'
C8	139.65'	320.00'	25°00'17"	N76°50'37"W	138.55'
C9	17.64'	380.00'	2°39'34"	N88°00'59"W	17.64'
C10	74.24'	380.00'	11°11'38"	N81°05'23"W	74.12'
C11	90.63'	380.00'	13°39'55"	N68°39'36"W	90.42'
C12	21.44'	15.00'	81°54'21"	N77°13'11"E	19.66'
C13	22.25'	15.00'	85°00'23"	S6°14'11"E	20.27'
C14	125.86'	380.40'	18°57'23"	N39°15'23"W	125.28'

Curve Table

CURVE DATA	ARC LENGTH	RADIUS	DELTA ANGLE	CHORD BEARING	CHORD
C15	49.53'	25.00'	113°31'28"	S86°58'15"E	41.82'
C16	42.25'	780.00'	3°06'12"	S37°49'06"W	42.24'
C17	12.95'	780.00'	0°57'05"	N39°50'43"E	12.95'
C18	16.95'	270.00'	3°35'46"	N58°42'40"W	16.94'
C19	153.81'	330.00'	26°42'16"	S43°33'39"E	152.42'
C20	333.24'	320.05'	59°39'25"	N59°30'54"W	318.39'
C21	182.51'	380.00'	27°31'07"	N75°35'12"W	180.76'

LINE DATA

LINE NUMBER	BEARING	DISTANCE
L1	S39°26'18"W	15.38'
L2	S89°20'45"E	4.02'
L3	S89°20'45"E	25.17'
L4	S45°25'18"W	35.57'



SCALE 1"=80'



Clapsaddle-Garber Associates, Inc
16 East Main Street
Marshalltown, Iowa 50158
Ph 641-752-6701
www.cgaconsultants.com

DRAWN CAQ	SHEET NO. 3 OF 4
DATE 7-5-2022	PROJECT NO. 5805.05

FINAL PLAT WILD HORSE RIDGE SIXTH ADDITION CEDAR FALLS, IOWA

NW1/4 NE1/4
SEC. 16-89-14
PARCEL "C"
INSTR #2016-00015368
MIDWEST
DEVELOPMENT
COMPANY

PARCEL "D"
INSTR #2016-00015368
MIDWEST
DEVELOPMENT
COMPANY

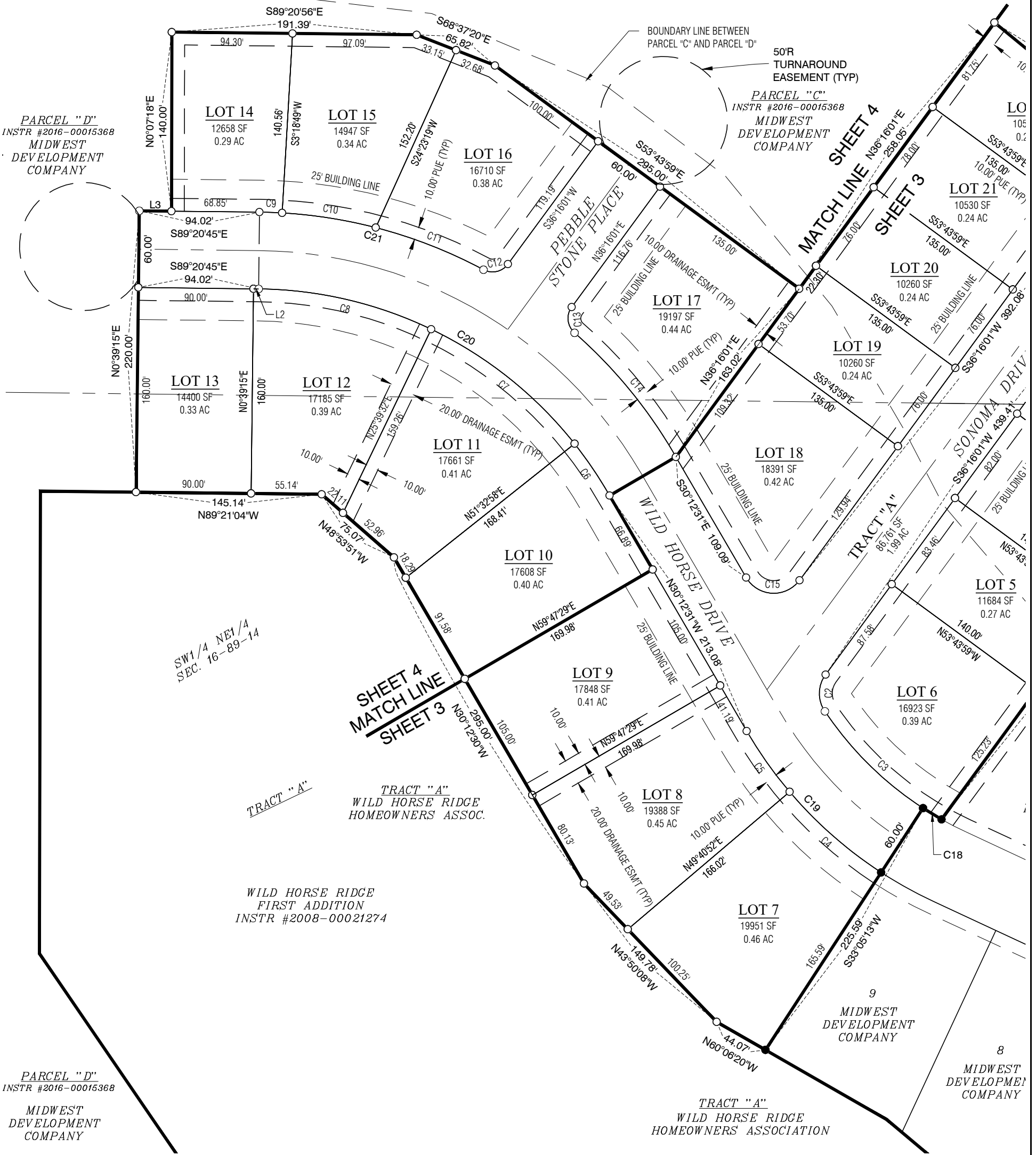

SW1/4 NE1/4
SEC. 16-89-14

WILD HORSE RIDGE
FIRST ADDITION
INSTR #2008-00021274

PARCEL "D"
INSTR #2016-00015368
MIDWEST
DEVELOPMENT
COMPANY

TRACT "A"
WILD HORSE RIDGE
HOMEOWNERS ASSOCIATION

Clapsaddle-Garber Associates, Inc
16 East Main Street
Marshalltown, Iowa 50158
Ph 641-752-6701
www.cgaconsultants.com

DRAWN CAQ	SHEET NO. 4 OF 4
DATE 7-5-2022	PROJECT NO. 5805.05

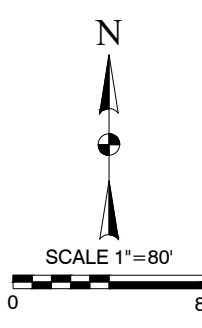

Prepared by: Richard R. Morris, 620 Lafayette Street, Ste. 300, PO Box 178, Waterloo, IA 50704 (319) 234-1766

DEED OF DEDICATION
OF
WILD HORSE RIDGE SIXTH ADDITION,
IN THE CITY OF CEDAR FALLS, BLACK HAWK COUNTY, IOWA

KNOW ALL MEN BY THESE PRESENTS:

That Midwest Development Co., an Iowa corporation, with its principal office in Cedar Rapids, Iowa, being desirous of setting out and platting into lots and streets the land described in the attached Certificate of Survey by Travis R. Stewart, a licensed land surveyor, dated the 16th day of December 2022, do by these presents designate and set apart the aforesaid premises as a subdivision of the City of Cedar Falls, Iowa, the same to be known as:

WILD HORSE RIDGE SIXTH ADDITION,
IN THE CITY OF CEDAR FALLS, BLACK HAWK COUNTY, IOWA,

all of which is with the free consent and the desire of the undersigned and the undersigned do hereby designate and set apart for public use the streets and avenues as shown upon the attached plat.

EASEMENTS

The undersigned do hereby grant and convey to the City of Cedar Falls, its successors and assigns, and to any private corporation, firm or person furnishing utilities for the transmission and/or distribution of water, sanitary sewer, storm sewer, drain tile, surface drainage, gas, electricity, communication service or cable television, perpetual easements for the erection, laying, building, construction, reconstruction and maintenance of said services over, across, on and/or under the property as shown on the attached plat.

A perpetual easement is reserved along the lot lines of said lots as shown by the recorded plat for storm sewer, sanitary sewer, storm water drainage and utility installation and maintenance. There shall be no fences, buildings, large plantings or other obstructions upon or under the property covered by these easements, so that access is available for any equipment and/or persons necessary for the construction, reconstruction or maintenance of said utilities and/or drainage ways. Drainage easements exist ten feet along the rear of lots 1 through 6, 17-22. There is also a twenty-foot drainage easement between lots 8

and 9 and 11 and 12 with ten foot of said easement on each of those four lots. There is a public utility easement of ten feet along the street frontage of all lots in this subdivision.

RESTRICTIONS

Be it also known that the undersigned do hereby covenant and agree for themselves and their successors and assigns that each and all of the residential lots in said subdivision be and the same are hereby made subject to the following restrictions upon their use and occupancy as fully and effectively to all intents and purposes as if the same were contained and set forth in each deed of conveyance or mortgage that the undersigned or their successors in interest may hereinafter make for any of said lots and that such restrictions shall run with the land and with each individual lot thereof for the length of time and in all particulars hereinafter stated, to-wit:

1. Any dwelling that shall be erected on any lot shall have a minimum setback from the front of the lot line of 25 feet as indicated on the plat. No building shall be erected nearer to an interior sideline than 5 feet of the owner's lot width, provided however, that corner lots within the addition require a 25 foot setback from each street bordering said lot.

2. Although lots in said Addition may be split or divided in any fashion to provide for more lot area when added to an adjoining lot, no dwelling shall be built or maintained on any partial lot unless said partial lot is combined with an adjoining lot or partial lot so that the resulting lot has no less frontage than the smallest lot as indicated on the plat. The side yard setbacks set forth in paragraph 1. above shall be based on ownership property lines rather than platted lot lines.

3. No buildings or structure not attached to the original structure shall be constructed upon any lot or combination of lots in this subdivision, with the exception of a gazebo which has been approved in accordance with Paragraph 21 hereof. Sheds may be permitted but only if size, design, and materials are approved in writing by the developer. After completion of all houses in the plat, approval for a shed not previously approved by the developer shall be approved by the Association.

4. No trailer, basement, tent, shack, garage or barn erected in said Addition shall at any time be used as a residence, temporarily or permanently, nor shall any residence of a temporary character be permitted on any lot in said Addition.

5. Only single family dwellings shall be constructed on all lots in this subdivision.

6. No single family dwelling shall be constructed, permitted or occupied on any lot herein having square footage floor space, designed, intended and constructed for living quarters, which space shall not include cellars, attics, garages, breezeways, porches, stoops, and other such non-living areas, of less than the following requirements:

- A. 1,700 square feet for single story or 2,000 square feet for split-level or two story houses with the first or main floor having a minimum of 900 square feet or more on said first or main floor on Lots 7-13.
- B. 1,400 square feet for single story or split-level houses, except on Lots 7-13.

- C. 700 square feet on the first floor level for any house of more than one story and total minimum square footage must be at least 1,400, except on Lots 7-13.

7. Each single family residence shall have a minimum of a two-car attached garage with a minimum of 420 square feet, except Lots 7-13 which must have a minimum of a three-car attached garage with a minimum of 650 square feet.

8. The owner of each lot, vacant or improved, shall keep his lot or lots free of weeds and debris. Further, the owner and/or occupant of each lot shall jointly and severally be responsible to keep in good order or to maintain the area between the curblineline and the property line abutting his property including keeping said area free of holes, pitfalls, stumps of trees, fences, brick, stone, cement or other monument-type mail boxes, stakes, post or rods to which a metal, plastic or similar receptacle designed to hold newspapers are affixed, private irrigation or sprinkler systems, retaining walls, landscaping brick, block, stone, timber or other similar material, or any other similar obstructions. No individual mailboxes are allowed in this subdivision; a cluster-style mailbox system, approved by the United States Postal Service, shall be installed by the Developer.

9. No obnoxious or offensive trade or activity shall be carried on upon any lot nor shall anything be done thereon which may be or become an annoyance or nuisance to the neighborhood.

10. All approaches and driveways in said Addition shall be paved with concrete.

11. No dwelling on any lot in said Addition shall be occupied until the exterior is completed and finished and the interior substantially completed and finished.

12. No old or used buildings shall be moved upon any of the lots in said Addition for any purpose.

13. All electrical distribution lines and service entrances, all telephone lines and services therefor, all cable TV/fiber optic cable and service therefor, and all other utilities of whatever kind or nature shall be installed underground on all lots in said Addition.

14. No dog compound, enclosure, shelter, storage outbuilding, playhouse, or wood pile for firewood shall be constructed, used or maintained within ten feet of any lot line nor shall they exceed eight feet in height on any of said lots. All outbuilding exteriors shall be approved by the developer in writing prior to start of construction.

15. No radio station or short-wave operators of any kind shall operate from any lot which shall cause interference with audio or visual reception upon any other lot. Antennas are permitted if attached to the structure and do not extend more than eight feet above the peak of the home. All other antennas, satellite TV dishes in excess of 24 inches in diameter, poles for radios, and windmills are prohibited.

16. No motor home or recreational vehicle, trailer of any kind, whether camping, boat, house, utility or otherwise, shall be parked or kept for more than a 48 hour period on any street, driveway or on the lot in said Addition. Any such vehicle must be stored inside the garage.

17. No bus, semi-tractor, trailer or truck of any kind, except what is commonly described as a "pickup truck", shall be kept or parked on any lot or street in said Addition; provided, however, that this prohibition shall not apply to such vehicles driven in said Addition in pursuit of and in conducting their usual business.

18. No shrubs or trees shall be planted so as to infringe upon adjoining property lines based on maximum expected growth and shall be maintained so as not to infringe.

19. Each person or entity who is a record owner of a fee or undivided fee interest in any lot shall be a member of the Homeowners Association to be known as Wild Horse Ridge Homeowners Association. This shall not be construed to include persons or entities who hold an interest merely as security for the performance of an obligation. There shall be one vote per lot and each lot owner shall be a member of the Homeowners Association. Membership shall be appurtenant to and may not be separated from ownership of any lot; ownership of such lot shall be the sole qualification of membership.

The purpose of Wild Horse Ridge Homeowners Association shall be to maintain the common areas and green spaces of the entire development, including but not limited to the entrance parcel and signage to be developed, including the signage easement that is the east 40 feet of Lot 8 in Wild Horse Ridge Third Addition to the City of Cedar Falls, Black Hawk County, Iowa, as well as the pond which is owned by the Wild Horse Ridge Homeowners Association, and such other activities as set forth in the Articles of Incorporation and Bylaws of the Association. Such ownership and maintenance shall include, but not be limited to, mowing, watering, including upkeep of any underground sprinkler system, maintenance of the pond, and snow removal of common areas. Initially, the developer, Midwest Development Co. shall perform the actual construction duties to establish the common areas, green spaces, entrance and surrounding access area.

The annual dues for the Association shall initially be set at \$200.00 per lot per year beginning January 1, 2022. Dues shall be paid by each member of the Association by July 31 of each year. The Association shall have the ability and authority to adjust annual dues as it deems appropriate to carry out the maintenance duties described above. The developer, Midwest Development Co., shall have no responsibility for annual association dues.

20. No building or structure shall be erected or placed on any lot in this subdivision until two sets of building plans, site plans and specifications for the proposed structures shall be submitted to Midwest Development Co. or its designee for approval. Approved plans, site plans and building specifications will be signed and one set of each returned to the Lot Owner. In addition to plans and specifications for the structure, the site plan application shall show the location and type of fences, parking areas, tree plantings, landscaping and other relevant matters, including the location on the lot of all proposed improvements, including whether or not there is a proposed swimming pool which must be an in ground pool only, the materials to be used and the exterior color scheme proposed. No building shall have less than a 6 and 12 pitch roof unless otherwise specifically approved in writing by Midwest Development Co. or its designee. Roofing materials shall be asphalt shingles (25 year minimum rating), wood shakes, wood shingles, slate or tile unless other materials are specifically approved by Midwest Development Co. or its designee. The application shall also set forth a time schedule for construction of improvements and in no event shall an application be approved when the proposed construction will take longer than twelve (12) months. Midwest Development Co. or its designee shall approve or disapprove the application in writing within a period of ten (10) days after receipt of all the documents and in the event of disapproval shall specify the reasons to enable the applicant to correct the application in order to obtain approval. Midwest Development Co. reserves the absolute right and sole discretion, to reject any

of the plans, specifications and other aspects of the proposed improvement which in Midwest Development Co.'s opinion is not suitable or desirable for the subdivision. It is the intention of this restriction to permit improvement that will enhance the aesthetics of the subdivision and maintain or improve property values.

21. All of the provisions hereof shall be enforceable by appropriate legal proceedings by any present or future owner of the legal or equitable title to any lot in said subdivision. Invalidation of any one or more of the within restrictions by judgment or decree of court shall not be regarded as affecting the validity of any of the other provisions hereof, nor shall any judicial determination with respect to any of the restrictive provisions hereof be regarded as affecting the validity or sufficiency of this instrument as a deed of dedication of said plat, all of which such other provisions shall remain in full force and effect.

22. The undersigned and all persons and corporations hereafter requiring any right, title or interest in any of the lots in said subdivision shall be taken and held to have agreed and covenanted with the owners of all other lots in this subdivision and with the respective successors and assigns of all of the rest of such other lots to conform to and observe all of the foregoing covenants, restrictions and stipulations as to the construction of building thereon for a period of twenty-one (21) years from the date of filing of said plat and this deed of dedication for record. Within the period of twenty-one (21) years and in accordance with Iowa Code Chapter 614.24 and 614.25 (2021 Code of Iowa) or their successor provisions, these covenants, restrictions and stipulations shall be automatically extended for an additional period of twenty-one (21) years upon compliance with Chapter 614.24 and Chapter 614.25 of the 2021 Code of Iowa. In the event an extension of the covenants, restrictions and stipulations is not filed within the period of twenty-one (21) years or successive 21-year period, then the covenants, restrictions and stipulations contained herein shall terminate at the end of the existing period of twenty-one (21) years.

23. If the parties hereto or any of them or their heirs or assigns shall violate or attempt to violate any of the covenants or restrictions herein, it shall be lawful for any other person or persons owning property in said Addition to prosecute any proceedings at law or in equity against the person or persons violating or attempting to violate any such covenants or restrictions and for the purpose of preventing such acts or to recover damages for such violation, or both, and for costs and reasonable attorney's fees as determined by the Court and not the statute.

24. No animals, livestock, or poultry of any kind shall be raised, bred or kept on any lot, except that two dogs or cats maximum, or other household pets are allowed and then only if they are not kept, bred or maintained for any commercial purposes. Such animals shall be kept under control so as not to constitute a public nuisance and must be kept in compliance with applicable zoning laws and regulations of the City of Cedar Falls, Black Hawk County, Iowa.

25. Upon the sale of a lot, owner shall take responsibility for any erosion control issues, certifications and/or requirements of the Iowa Department of Natural Resources.

26. All buildings erected on any lot in said Addition shall be constructed in accordance with all applicable statutes, ordinances, codes, rules, regulations, and standards of the City of Cedar Falls, Iowa.

**PUBLIC IMPROVEMENTS REQUIRED
IN WILD HORSE RIDGE SIXTH ADDITION**

The undersigned do hereby dedicate and set apart to the public and for the public's use all streets shown and laid out on the attached plat, subject to the easements set forth herein, and do further agree as follows:

- A. That the streets shown on the attached plat, Wild Horse Drive, Sonoma Drive and Pebble Stone Place (Tract "A") shall be thirty-one (31) feet and will be brought to City grade, back of curb to back of curb; said street with approved hard surface pavement in accordance with City of Cedar Falls, Standard Specifications.
- B. That sanitary sewer, together with the necessary manholes and sewer service lines to all lots in the plat, will be provided.
- C. That underground utilities, as required by the Subdivision Ordinance of the City of Cedar Falls, Iowa, shall be installed.
- D. That the city water will be provided to all lots as required by the Cedar Falls Municipal utilities.
- E. That municipal fire hydrants will be provided as required by the Cedar Falls Public Safety Department.
- F. That storm sewer will be provided as specified by the City Engineer.
- G. That handicap ramps will be provided as required by law.
- H. That a four (4) foot wide concrete sidewalk four (4) inches thick and a concrete surface or hard surface entrance will be installed during or immediately after the construction of the residence on any particular lot, or within five (5) years after the date the plat is filed in the office of the Recorder of Black Hawk County, whichever is sooner and that the sidewalk be across the full length of the lot and on corner lots also, across the parking and full length of the lot. In the event that the City is required to construct the sidewalk as permitted by subparagraph J, a lien or liens may only be imposed against the lot or lots which require city construction and no others in the subdivision.
- I. That the work improvements called for herein shall be in accordance with the specifications of the City of Cedar Falls, Iowa, and performed under the supervision of the City Engineer. In the event that the developer, Midwest Development Co., its grantees and assigns fail to complete said work and improvements called for herein within one (1) year from the date of the acceptance of said final plat by the City of Cedar Falls, Iowa, the City may then make the improvements and assess the costs of the same to the respective lots. The undersigned, for themselves, their successors, grantees and assigns, waive all statutory requirements of notice of time and place of hearing and agree that the City may install said improvements and assess the total costs thereof against the respective lots.

- J. That the City may perform said work, levy the cost thereof as assessments, and the undersigned agree that said assessments so levied shall be a lien on the respective lots with the same force and effect as though all legal provisions pertaining to the levy of such special assessments have been observed, and further authorize the City Clerk to certify such assessments to the County Auditor as assessments to be paid in installments as provided by law.
- K. The Developer shall construct and install all required public improvements within the subdivision plat, to conform with approved construction plans which meet the specifications of the City of Cedar Falls, Iowa. Such required public improvements shall meet the following requirements:
- (a) Shall be constructed and installed in a good and workmanlike manner;
 - (b) Shall be free of defects in workmanship or materials;
 - (c) Shall be free of any conditions that could result in structural or other failure of said improvements;
 - (d) Shall be constructed and installed in accordance with the design standards and technical standards established for such public improvements by the City and by Cedar Falls Utilities;
 - (e) Shall be constructed and installed in strict compliance with the minimum acceptable specifications for the construction of public improvements set forth in the Cedar Falls Code of Ordinances, including without limitation, Chapter 24, Subdivisions, and as such specifications shall be recommended for approval by the City Engineer from time to time, and approved by the city council.

The Developer's construction plans are now on file in the Office of the City Engineer.

27. The developer, Midwest Development Co., states:
- A. That this plat and development shall comply with the R-P Residential Zoning District Classification Regulations.

28. Notwithstanding anything contained in the Deed of Dedication to the contrary, any assessment made under the Deed of Dedication shall not be a lien against any property described herein unless and until the City of Cedar Falls records with the Black Hawk County Recorder a "Notice of Assessment Lien" which notice shall describe the property against which the lien attaches in the amount of said lien.

29. All subsequent owners of lots in the subdivision shall be obligated to meet any requirements imposed by the Commissioners of the Black Hawk County Conservation District or any other governmental agency, by the authority of Chapter 161A, Code of Iowa, pertaining to soil erosion control plans for certain land distributing activities. This covenant shall be perpetual and not be governed by the provisions of Paragraph 23 of this Deed of Dedication.

SIGNED and DATED this 20TH day of December, 2022.

MIDWEST DEVELOPMENT CO.

By [Signature]
Hunter Skogman, President Land Acquisition and Development

STATE OF IOWA, LINN COUNTY ss

This instrument was acknowledged before me on December 20TH, 2022, by Hunter Skogman as President Land Acquisition and Development, Midwest Development Co.

[Signature]
Notary Public in and for the State of Iowa



Michelle Pezley

From: Phil Kenealy <pkenealy@acesiowa.com>
Sent: Friday, November 18, 2022 3:52 PM
To: City Council
Cc: Michelle Pezley; Rob Green
Subject: Park or green space in Wild Horse Ridge Addition

CAUTION: This email originated outside the City of Cedar Falls email system.

Do not click links or open attachments unless you recognize the sender and know the content is safe.

Greetings Cedar Falls Councilpersons!

Thank you for your service to our community. I value your role in making Cedar Falls an incredible place to live and to raise a family.

There is a meeting for the approval of the final plat for Wild Horse Ridge 6th Addition at Planning and Zoning on Tuesday the 22nd. I would like to begin a discussion about adding green space or a park in the Wild Horse Ridge Addition to create a place for kids in the neighborhood to play. Currently, none of the plats that have been proposed for the new phases contain any park or green space. Last year I had a conversation with Michelle Pezley, a planner with the Planning and Zoning Department to inquire if this was a requirement for new additions. She directed me to the "Comprehensive Plan" for the city. On page 152 of the comprehensive plan under Park Financing, this statement can be found, "To require dedication of land by developers, Cedar Falls should establish a park land dedication policy for all new developments".

It appears that this framework defined in the comprehensive plan is not being followed by developers or required by the city. I don't know if that is a planning and zoning issue or if it is something that the council might consider. So, this week I contacted Daryl Kruse of the 3rd Ward to explore this issue. Daryl encouraged me to bring the issue up with all of the council to see if we could get a dialogue started.

So, I propose that the city council establish a park land dedication policy for all new developments (starting with Wild Horse Ridge 6th Addition 😊) as outlined in the comprehensive plan. I intend to attend the final plat approval meeting on Tuesday to introduce this thought. I'm happy to discuss the topic with any of you in attendance or feel free to contact me by phone if you wish.

Thanks!

Respectfully,

PHIL KENEALY
(319) 230-9776

This email is confidential and may be legally privileged. If you are not the intended recipient, please delete the message.

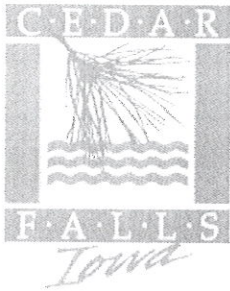

PUBLIC WORKS DEPARTMENT

City of Cedar Falls
 501 E. 4th Street
 Cedar Falls, Iowa 50613
 319-273-8633

MEMORANDUM

Water Reclamation Division

TO: Honorable Mayor Robert M. Green and City Council
FROM: Tyler Griffin, Acting Water Reclamation Manager
DATE: January 5, 2023
SUBJECT: UV Disinfection Lamp Replacement

The CIP for FY23 estimated \$60,000 for the replacement of 420 ultraviolet lamps used in the UV disinfection process at the treatment plant. These lamps were last replaced in 2019 and have an effective life of 12,000 hours. The current lamps are nearing this threshold and need to be replaced for disinfection to remain effective as required by our NPDES permit.

Three distributors responded to requests for quotes. Please see the breakdown below.

Veolia, Suez,	\$150 per lamp for a total cost of \$63,000
UV Superstore,	\$150 per lamp for a total cost of \$63,000
UV Doctor,	\$165 per lamp for a total cost of \$69,300

I am requesting the approval to purchase 420 lamps for a total cost of \$63,000 from Veolia, Suez Treatment Solutions, the original equipment manufacturer, of our UV disinfection system. The lamps will be purchased with Sewer Rental Funds.

CC: Chase Schrage, Public Works Director

	SUEZ TREATMENT SOLUTIONS INC 600 WILLOW TREE RD LEONIA NJ 07605 UNITED STATES PHONE: 201-676-2525	Quotation				
Quote Date	Quotation Exp. Date	Suez TS Quote				
12DEC2022	31JAN2023	20563105				
Sales org.	Sales Representative / Contact	Reference				
B611	Tyler J. Griffin	UV Lamps				
Sold to : 1000151421 CITY OF CEDAR FALLS 501 EAST FOURTH STREET CEDAR FALLS IA 50613 UNITED STATES		Ship to : 4000217371 CITY OF CEDAR FALLS Tyler J. Griffin 319-268-5559 501 EAST FOURTH STREET CEDAR FALLS IA 50613 UNITED STATES				
Bill to : 0000510731 CITY OF CEDAR FALLS 501 EAST FOURTH STREET CEDAR FALLS IA 50613 UNITED STATES		Payment terms Net 30 Days From Invoice Date				
		Inco terms EXW FACTORY				
Currency: U.S. Dollar		Freight: Freight Prepaid				
SNo.	Part Number / Item Description	Quantity	Unit	Price	Unit	Amount
10	X0016A15 LAMP, COMPLETE ASSY, UV 3X, 400W 420 EA	420	EA	150.00	EA	63,000.00
					NET PRICE	USD 63,000.00
					FREIGHT & HANDLING	USD 685.00
					TOTAL AMOUNT	63,685.00

Thank you for your Consideration. To place an order, please fax signed Purchase Orders to the Customer Care number shown above.
 To ensure that you receive the pricing quoted, please reference this quotation number on your order.
 All sales are subject to our terms and conditions, contained with this quotation.
 Freight for Bulk Delivery and specialized freight charges, where applicable, are not included unless specifically indicated in the materials listing above.
 Pricing above does not include applicable taxes, which will be applied at time of order.



Mike Roberts
 UV Superstore, Inc.
 820 Tucker Ct.
 Winder, GA 30680
 P: (770) 307-3882
 F: (770) 307-3872

mike@uvsuperstore.com

Quotation

Quote Number: 22-140197
 Quote Date: Dec 13, 2022
 Customer ID: UVSS
 Payment Terms: Prepaid

This quote is valid until: 1/12/23

Quoted To:

Prospective Customer

Ship To:

tyler.griffin@cedarfalls.com
 City of Cedar Falls
 Tyler Griffin

Qty.	Description	Unit Price	Amount
420	P/N 4229 (AKA G64-X0016-H10) UV LAMP 254NM AMALGAM OLD SPEC # 3849 QUOTE INCLUDES FREIGHT TO DESTINATION LEAD TIME 4-5 WEEKS	150.00	63,000.00

Please be advised:

The price(s) for the item(s) quoted do not include shipping, duties and taxes unless otherwise stated.

All prices are in US Dollars. F.O.B. shipping point.

UV Superstore has a minimum order of \$50.00

Subtotal	63,000.00
Sales Tax	
TOTAL	63,000.00

12/13/22 3:17 PM

One Source for all Your UV Needs!



Date Dec 13, 2022

Cedar Falls, IA

Tyler Griffin
501 E. Fourth Street
Cedar Falls, IA 50613

QUOTE # CEDAR-FALLS-IA-12-13

Please review the quote:

Line	Qty	Part #	Description	USD Price	Ext. Price
1	420	1620	UV Lamp - replaces Ozonia 3X lamp #X0016-H10	\$165.00	\$69,300.00
2	1	Freight	Delivery fee	\$500.00	\$500.00

Total	\$69,800.00
--------------	--------------------

Payment Terms: Net 30 days for approved credit.
Shipping Terms: FOB Newport, WA
Quote is valid for 90 days
Delivery: 4 to 6 weeks. Due to Covid-19, delivery times may vary.

Sincerely,

Robert Merillat

Robert Merillat
Sales Team

209 S. WASHINGTON AVE. NEWPORT WA 99156

TEL: (509) 447-5800 - FAX: (509) 447-5822



DEPARTMENT OF PUBLIC WORKS

City of Cedar Falls
 220 Clay Street
 Cedar Falls, Iowa 50613
 Phone: 319-268-5161
 Fax: 319-268-5197
 www.cedarfalls.com

MEMORANDUM
Engineering Division

TO: Honorable Mayor Robert M. Green and City Council

FROM: Ben Claypool, Principal Engineer, PhD, EI

DATE: January 9, 2023

SUBJECT: College Hill Parking Lot Improvements
 Project No. PL-101-3264
 Project Final Acceptance

The College Hill Parking Lot Improvements project is completed and ready for final acceptance. This project involved the restoration of two parking lots in the College Hill district. This project was under contract with Aspro, Inc of Waterloo, Iowa. This was Item 34 in the FY23 Fiscal Year CIP. Attached please find the following final documents:

- Final Pay Estimate (releases retainage)
- Copy of Maintenance Bond, Aspro, Inc

The following lien waivers have been received, reviewed by the Engineering Division, and are on file with the City Clerk:

Aspro Suppliers:
 BMC Aggregates
 Bituminous Materials & Supply Co. LP
 Manatts Inc

Funding Source	Attributed Costs
Tax Increment Financing – College Hill	\$155,677.13

I certify that the public improvements for the College Hill Parking Lot Improvements were completed in reasonable compliance with the project plans and specifications.

 Ben Claypool 1/9/2023
 Date

xc: Chase Schrage, Director of Public Works
 David Wicke, P.E., City Engineer
 Lisa Roeding, Controller/City Treasurer

CEDAR FALLS
CONTRACTOR'S APPLICATION FOR PAYMENT
Retainage Release
Pay Application

College Hill Parking Lot Improvements
 Project Number: PL-101-3264
 Contract Completion Date: 07/01/22

Application Period: 06/30/22 to 01/09/23
 To (Owner): City of Cedar Falls
 From (Contractor): Aspro, Inc

Application Date: 1/9/23
 Via (Engineer): Ben Claypool
 Principal Engineer

Change Order Summary		
Approved Change Orders:		
Number	Additions (a)	Deductions (b)
1	\$ -	\$ -
2	\$ -	\$ -
3	\$ -	\$ -
4	\$ -	\$ -
5	\$ -	\$ -
6	\$ -	\$ -
7	\$ -	\$ -
8	\$ -	\$ -
9	\$ -	\$ -
10	\$ -	\$ -
11	\$ -	\$ -
12	\$ -	\$ -
13	\$ -	\$ -
14	\$ -	\$ -
15	\$ -	\$ -
Totals	\$ -	\$ -
Net Change by Change Orders		
(a) + (b) = (c)	\$	-

Contractor's Certification

The undersigned Contractor certifies that: (1) all previous progress payments received from Owner on account of Work done under the Contract have been applied on account to discharge Contractor's legitimate obligations incurred in connection with Work covered by prior Applications for Payment; (2) title of all Work, materials and equipment incorporated in said Work or otherwise listed in or covered by this Application for Payment will pass to Owner at time of payment free and clear of all Liens, security interests and encumbrances (except such are covered by a Bond acceptable to Owner indemnifying Owner against such Liens, security interest or encumbrances); and (3) all Work covered by this Application for Payment is in accordance with the Contract Documents and is not defective.

By (Contractor): Brad Blough
 Date: 1-9-23 Brad Blough

1. ORIGINAL CONTRACT PRICE	\$	155,435.46
2. NET CHANGE BY CHANGE ORDERS (c)	\$	-
3. CURRENT CONTRACT PRICE	\$	155,435.46
4. TOTAL COMPLETED AND STORED TO DATE (Total Column F on Progress Estimate)	\$	155,677.13
5. RETAINAGE		
a. 5% x \$ - Work Completed	\$	-
b. 5% x \$ - Stored Materials	\$	-
c. Total Retainage (Line 5a + Line 5b)	\$	-
6. CUMULATIVE LIQUIDATED DAMAGES CHARGED 0 Days x _____ Per Day	\$	-
7. AMOUNT ELIGIBLE TO DATE (Line 4 - Line 5c - Line 6)	\$	155,677.13
8. LESS PREVIOUS PAYMENTS (Line 7 From Prior Application)	\$	147,893.27
9. AMOUNT DUE THIS APPLICATION	\$	7,783.86
10. BALANCE TO DATE, PLUS RETAINAGE (Line 7 + Line 5c)	\$	155,677.13
11. % OF COMPLETION		
Original Contract Price (Line 10 ÷ Line 1)		100%
Current Contract Price (Line 10 ÷ Line 3)		100%

Payment of: **\$ 7,783.86** (Line 9 or Other: Attach Explanation if Other Amount)

Is Respectfully Submitted: Benjamin Claypool 1/9/23
 Ben Claypool, Principal Engineer Date

CONTRACTOR'S APPLICATION FOR PAYMENT			No. Retainage Release								Estimate				
College Hill Parking Lot Improvements			Application Period: 06/30/22 to 01/09/23				Application Date: 01/09/22								
Project Number: PL-101-3264			To (Owner): City of Cedar Falls				Via (Engineer): Ben Claypool								
Contract Completion Date: 07/01/22			From (Contractor): Aspro, Inc				Principal Engineer								
A	B	C	D	E	F	G	H	I	J	K	L	M	N	O	
Item			Bid Quantity	Unit Price	Bid Value	Previous Pay Application Quantities	Current Pay Application Quantities	Current Pay Application Value (E x H)	Estimated Quantity Installed (G + H)	Total Completed Value (E x J)	Value of Materials Presently Stored (Column M on Stored Materials)	Total Completed and Stored to Date (K + L)	% Original Contract (M + F)	Balance to Date (F - M)	Item Completed
Bid Item Number	Description	Unit													
1	HMA Overlay, (ST), Base Course, 1.5", PG58-28S	TON	418.50	\$ 127.50	\$ 53,358.75	876.83	-	\$ -	876.83	\$ 111,795.83	\$ -	\$ 111,795.83	210%	\$ (58,437.08)	X
2	HMA Overlay, (ST), Surface Course, 1.5", PG58-28S	TON	454.60	\$ 129.00	\$ 58,643.40	-	-	\$ -	-	\$ -	\$ -	\$ -	0%	\$ 58,643.40	X
3	Full Depth Patching, PCC, 7" Depth	SY	22.30	\$ 112.00	\$ 2,497.60	26.30	-	\$ -	26.30	\$ 2,945.60	\$ -	\$ 2,945.60	118%	\$ (448.00)	X
4	Milling, 3"	SY	4,995.70	\$ 5.65	\$ 28,225.71	4,995.70	-	\$ -	4,995.70	\$ 28,225.71	\$ -	\$ 28,225.71	100%	\$ -	X
5	Painted Pavement Markings, Solvent/Waterborne	STA	26.80	\$ 100.00	\$ 2,680.00	26.80	-	\$ -	26.80	\$ 2,680.00	\$ -	\$ 2,680.00	100%	\$ -	X
6	Painted Pavement Symbols & Legends	EACH	5.00	\$ 60.00	\$ 300.00	5.00	-	\$ -	5.00	\$ 300.00	\$ -	\$ 300.00	100%	\$ -	X
7	Traffic Control	LS	1.00	\$ 3,000.00	\$ 3,000.00	1.00	-	\$ -	1.00	\$ 3,000.00	\$ -	\$ 3,000.00	100%	\$ -	X
8	Wattles	LF	20.00	\$ 4.00	\$ 80.00	20.00	-	\$ -	20.00	\$ 80.00	\$ -	\$ 80.00	100%	\$ -	X
9	Mobilization	LS	1.00	\$ 5,600.00	\$ 5,600.00	1.00	-	\$ -	1.00	\$ 5,600.00	\$ -	\$ 5,600.00	100%	\$ -	X
10	PCC Curb Flume	LS	1.00	\$ 1,050.00	\$ 1,050.00	1.00	-	\$ -	1.00	\$ 1,050.00	\$ -	\$ 1,050.00	100%	\$ -	X
Totals					\$ 155,435.46			\$ -		\$ 155,677.13	\$ -	\$ 155,677.13		\$ (241.68)	

Performance, Payment and Maintenance Bond

SURETY BOND NO. _____

KNOW ALL BY THESE PRESENTS:

That we, _____, as Principal (hereinafter the “Contractor” or “Principal” and _____ as Surety are held and firmly bound unto CITY OF CEDAR FALLS, IOWA, as Obligee (hereinafter referred to as “the Owner”), and to all persons who may be injured by any breach of any of the conditions of this Bond in the penal sum of _____ (\$ _____), lawful money of the United States, for the payment of which sum, well and truly to be made, we bind ourselves, our heirs, legal representatives and assigns, jointly or severally, firmly by these presents.

The conditions of the above obligations are such that whereas said Contractor entered into a contract with the Owner, bearing date the _____ day of _____, 2022, hereinafter the “Contract”) wherein said Contractor undertakes and agrees to construct the following described improvements:

COLLEGE HILL PARKING LOT IMPROVEMENTS PROJECT Project PL-101-3264

and to faithfully perform all the terms and requirements of said Contract within the time therein specified, in a good and workmanlike manner, and in accordance with the Contract Documents.

It is expressly understood and agreed by the Contractor and Surety in this bond that the following provisions are a part of this Bond and are binding upon said Contractor and Surety, to-wit:

1. **PERFORMANCE:** The Contractor shall well and faithfully observe, perform, fulfill, and abide by each and every covenant, condition, and part of said Contract and Contract Documents, by reference made a part hereof, for the above referenced improvements, and shall indemnify and save harmless the Owner from all outlay and expense incurred by the Owner by reason of the Contractor’s default or failure to perform as required. The Contractor shall also be responsible for the default or failure to perform as required under the Contract and Contract Documents by all its subcontractors, suppliers, agents, or employees furnishing materials or providing labor in the performance of the Contract.
2. **PAYMENT:** The Contractor and the Surety on this Bond hereby agreed to pay all just claims submitted by persons, firms, subcontractors, and corporations furnishing materials for or performing labor in the performance of the Contract on account of which this Bond is given, including but not limited to claims for all amounts due for labor, materials, lubricants, oil, gasoline, repairs on machinery, equipment, and tools, consumed or used by the Contractor or any subcontractor, wherein the same are not satisfied out of the portion of the contract price the Owner is required to retain until completion of the improvement, but the Contractor and Surety shall not be liable to said persons, firms, or corporations unless the claims of said claimants against said portion of the contract price shall have been established as provided by law. The Contractor and Surety hereby bind themselves to the obligations and conditions set forth in Chapter 573 of the Iowa Code, which by this reference is made a part hereof as though fully set out herein.
3. **MAINTENANCE:** The Contractor and the Surety on this Bond hereby agree, at their own expense:

- A. To remedy any and all defects that may develop in or result from work to be performed under the Contract within the period of 2 year (s) from the date of acceptance of the work under the Contract, by reason of defects in workmanship or materials used in construction of said work;
- B. To keep all work in continuous good repair; and
- C. To pay the Owner's reasonable costs of monitoring and inspection to assure that any defects are remedied, and to repay the Owner all outlay and expense incurred as a result of Contractor's and Surety's failure to remedy any defect as required by this section.

Contractor's and Surety's agreement herein made extends to defects in workmanship or materials not discovered or known to the Owner at the time such work was accepted.

4. GENERAL: Every Surety on this Bond shall be deemed and held bound, any contract to the contrary notwithstanding, to the following provisions:

- A. To consent without notice to any extension of time to the Contractor in which to perform the Contract;
- B. To consent without notice to any change in the Contract or Contract Documents, which thereby increases the total contract price and the penal sum of this bond, provided that all such changes do not, in the aggregate, involve an increase of more than 20% of the total contract price, and that this bond shall then be released as to such excess increase; and
- C. To consent without notice that this Bond shall remain in full force and effect until the Contract is completed, whether completed within the specified contract period, within an extension thereof, or within a period of time after the contract period has elapsed and the liquidated damage penalty is being charged against the Contractor.

The Contractor and every Surety on the bond shall be deemed and held bound, any contract to the contrary notwithstanding, to the following provisions:

- D. That no provision of this Bond or of any other contract shall be valid that limits to less than five years after the acceptance of the work under the Contract the right to sue on this Bond.
- E. That as used herein, the phrase "all outlay and expense" is not to be limited in any way, but shall include the actual and reasonable costs and expenses incurred by the Owner including interest, benefits, and overhead where applicable. Accordingly, "all outlay and expense" would include but not be limited to all contract or employee expense, all equipment usage or rental, materials, testing, outside experts, attorney's fees (including overhead expenses of the Owner's staff attorneys), and all costs and expenses of litigation as they are incurred by the Owner. It is intended the Contractor and Surety will defend and indemnify the Owner on all claims made against the Owner on account of Contractor's failure to perform as required in the Contract and Contract Documents, that all agreements and promises set forth in the Contract and Contract Documents, in approved change orders, and in this Bond will be fulfilled, and that the Owner will be fully indemnified so that it will be put into the position it would have been in had the Contract been performed in the first instance as required.

In the event the Owner incurs any “outlay and expense” in defending itself against any claim as to which the Contractor or Surety should have provided the defense, or in the enforcement of the promises given by the Contractor in the Contract, Contract Documents, or approved change orders, or in the enforcement of the promises given by the Contractor and Surety in this Bond, the Contractor and Surety agree that they will make the Owner whole for all such outlay and expense, provided that the Surety’s obligation under this bond shall not exceed 125% of the penal sum of this bond.

In the event that any actions or proceedings are initiated regarding this Bond, the parties agree that the venue thereof shall be in the Iowa District Court for Black Hawk County, State of Iowa. If legal action is required by the Owner to enforce the provisions of this Bond or to collect the monetary obligation incurring to the benefit of the Owner, the Contractor and the Surety agree, jointly, and severally, to pay the Owner all outlay and expense incurred therefor by the Owner. All rights, powers, and remedies of the Owner hereunder shall be cumulative and not alternative and shall be in addition to all rights, powers, and remedies given to the Owner, by law. The Owner may proceed against surety for any amount guaranteed hereunder whether action is brought against the Contractor or whether Contractor is joined in any such action(s) or not.

NOW THEREFORE, the condition of this obligation is such that if said Principal shall faithfully perform all the promises of the Principal, as set forth and provided in the Contract, in the Contract Documents, and in this Bond, then this obligation shall be null and void, otherwise it shall remain in full force and effect.

When a work, term, or phrase is used in this Bond, it shall be interpreted or construed first as defined in this Bond, the Contract, or the Contract Documents; second, if not defined in the Bond, Contract, or Contract Documents, it shall be interpreted or construed as defined in applicable provisions of the Iowa Code; third, if not defined in the Iowa Code, it shall be interpreted or construed according to its generally accepted meaning in the construction industry; and fourth, if it has no generally accepted meaning in the construction industry, it shall be interpreted or construed according to its common or customary usage.

Failure to specify or particularize shall not exclude terms or provisions not mentioned and shall not limit liability hereunder. The Contract and Contract Documents are hereby made a part of this Bond.

Project No. PL-101-3264

Witness our hands, in triplicate, this _____ day of _____, 2022.

Surety Countersigned By:

PRINCIPAL:

Signature of Agent

Contractor

By: _____
Signature

Printed Name of Agent

Title

SURETY:

Company Name

Surety Company

Company Address

By: _____
Signature Attorney-in-Fact Officer

City, State, Zip Code

Printed Name of Attorney-in-Fact Officer

Company Telephone Number

Company Name

FORM APPROVED BY:

Company Address

Attorney for Owner

City, State, Zip Code

Company Telephone Number

NOTE:

1. All signatures on this performance, payment, and maintenance bond must be original signatures in ink; copies, facsimile, or electronic signatures will not be accepted.
2. This bond must be sealed with the Surety's raised, embossing seal.
3. The Certificate or Power of Attorney accompanying this bond must be valid on its face and sealed with the Surety's raised, embossing seal.
4. The name and signature of the Surety's Attorney-in-Fact/Officer entered on this bond must be exactly as listed on the Certificate or Power of Attorney accompanying this bond.

**DEPARTMENT OF PUBLIC WORKS**

City of Cedar Falls
220 Clay Street
Cedar Falls, Iowa 50613
Phone: 319-268-5161
Fax: 319-268-5197
www.cedarfalls.com

MEMORANDUM
Engineering Division

TO: Honorable Mayor Robert M. Green and City Council

FROM: Matthew Tolan, EI, Civil Engineer II

DATE: January 9, 2023

SUBJECT: Fiber Optic License Agreement
Aureon Network Services
W. 2nd Street

Enclosed is a proposed License Agreement between the City of Cedar Falls and Aureon Network Services to install an additional long-distance telecommunications system consisting of fiber optic cable within the public right-of way of the City, in order to extend and upgrade services owned by Aureon Network Services along W. 2nd Street.

The City of Cedar Falls has entered into previous license agreements with Iowa Network Services, now Aureon Network Services. The proposed License Agreement follows the terms and conditions set forth in the earlier agreements and is intended to protect the City of Cedar Falls right-of way and manage and regulate in a manner consistent with federal and state law.

The Engineering Division of the Public Works Department recommends your approval of this proposed License Agreement.

xc: David Wicke, PE, City Engineer
Chase Schrage, Director of Public Works
Lisa Roeding, Controller/City Treasurer

Prepared by: Matthew Tolan, 220 Clay St., Cedar Falls, IA 50613, (319) 273-8600

LICENSE AGREEMENT

THIS LICENSE AGREEMENT (hereinafter the "Agreement"), is entered into by and between the City of Cedar Falls, Iowa, an Iowa municipality, whose address is 220 Clay Street, Cedar Falls, Iowa 50613 (hereinafter the "City"), and Aureon Network Services, whose address is 7760 Office Plaza Dr. S, West Des Moines, IA 50266, (hereinafter "Licensee").

Whereas, Licensee desires to acquire a license to construct, operate and maintain a certain communications systems within the City, the City is willing to grant such a license on certain terms and conditions, and the parties desire to reduce the agreement to writing.

NOW, THEREFORE, BE IT MUTUALLY COVENANTED AND AGREED BY THE PARTIES AS FOLLOWS:

1. Grant of License. City hereby grants Licensee a non-exclusive, limited license to construct, operate, maintain, inspect and repair a communications system which shall include all equipment owned, operated, leased or subleased in connection with the operation of one (1) fiber optic cable for data transmission and connection starting at the existing hand hole located in the easterly right-of-way of Franklin Street near the southwesterly property corner of 323 W. 2nd Street extending five hundred and thirty feet (530') easterly along the northerly right-of-way of W. 2nd Street to the southwesterly property corner of 205 W. 2nd Street in Cedar Falls, Iowa, including but not limited to poles, pedestals, wires, pipes, cables, underground conduits, ducts, manholes, vaults, fiber optic cables, and other structures, facilities or appurtenances, (hereinafter the "System") within the public right-of-way of the City, as generally depicted on Exhibit "A" attached hereto, and the parties agree that for purposes of this Agreement, the system route consists of approximately 530 linear feet of new fiber optic cables, subject to all rights and powers of the City under federal and Iowa law and Cedar Falls city ordinances, and subject to the terms and conditions set forth in this Agreement. Licensee acknowledges and understands that this license is non-exclusive, limited and subject to termination as provided in this Agreement. Any connections by

Licensee to any other facilities, or to other persons, businesses or entities, shall require an application by Licensee to the City for a separate license within a reasonable time after Licensee furnishes to City all information and documentation in support of Licensee's request for an additional license as may be reasonably required by this form of Agreement or by any ordinance subsequently adopted by the City as described in Section 5.

The facilities shall consist of one (1) two (2") inch High Density Polyethylene ("HDPE") with ninety-six (96) strands of fiber optic cable.

All of the underground cable shall be placed at a minimum depth of 42 inches (42") below ground level, unless approved by Licensor in writing.

Licensee shall obtain all necessary permits from the Iowa Department of Transportation for boring under any state or federal highways along the route, and any necessary consent from other jurisdictions and railroads as necessary for additional boring.

The minimum clearance between the duct and sewers, culverts and/or waterways shall be 36 inches (36").

2. Term of License. The term of the license granted to Licensee hereunder shall commence on the 20th day of December, 2022, and shall continue for a term of one (1) year, or until Licensee has completed the work to install its System, whichever occurs first.

3. License Fee.

a. Licensee shall pay to City an administrative license fee in the amount of \$170.45 payable upon execution of this Agreement, for the rights granted to Licensee as described in this License Agreement. Said license fee shall cover only the fee for the term of this Agreement set forth in Section 2. Licensee agrees that the administrative license fee is the City's estimate of the administrative burdens imposed on the City in connection with Licensee's application and its occupation of the City right-of-way, and Licensee agrees that it will not take any action, nor voluntarily provide support to any third-party action, to challenge the validity or reasonableness of such fee under applicable law. In addition to the administrative fee, Licensee shall pay permit fees and such other regulatory fees as may be required by applicable City ordinance.

b. Thereafter, Licensee shall have an annual license for the continued operation, inspection, maintenance and repair of Licensee's system, for a license fee in the amount of \$17.04 payable by Licensee to the City, for one (1) year period following the conclusion of the term provided in Section 2, and continuing for succeeding one (1) year terms, until termination of the license as described in Sections 4 or 21 of this Agreement. Licensee agrees that the annual license fee

is the City's estimate of the right-of-way management costs imposed on the City in connection with Licensee's occupancy of, and activities in and upon, the City right-of-way, and Licensee agrees that it will not take any action, nor voluntarily provide support to any third-party action, to challenge the validity or reasonableness of such annual license fee under applicable law. The annual license fee shall be payable annually no later than October 1st of each year. In addition to the annual license fee, Licensee shall pay permit fees and such other regulatory fees as may be required by applicable City ordinance. The amount of the annual license fee shall be subject to review and modification based upon the reasonable costs to City to administer and manage Licensee's continued use of the City right-of-way for each succeeding one (1) year term.

4. Removal of Facilities and System. Licensee shall remove its System and all facilities and infrastructure related thereto, upon the occurrence of any one of the following events:

- a. Licensee ceases to do business in the State of Iowa; or
- b. Licensee abandons its System, or discontinues use of the System for a consecutive period of twelve (12) months; or
- c. The end of the economic life of Licensee's System and the need for its replacement; or
- d. Licensee defaults in the performance of its duties and obligations under this Agreement, and fails to timely cure such default as provided in Section 21 of this Agreement.

Upon the happening of any one or more of the following events, Licensee shall promptly, and in no event later than ninety (90) days from the happening, remove its System and all facilities and all related infrastructure from the City right-of-way at Licensee's sole cost.

5. Enactment of City Ordinance. During the term of this Agreement, if the City enacts an ordinance requiring all providers of utilities, telecommunications or other information services to pay a fee to the City on a competitively-neutral and non-discriminatory basis for the use of City right-of-way, Licensee shall comply with the terms and conditions of said ordinance promptly upon enactment of said ordinance. If such ordinance requires annual license fees for the City's continued administration and management of such providers' use of the right-of-way, Licensee shall be entitled to a refund of a pro-rata portion of its annual license fee for the year in which such ordinance is enacted, provided, however, that in no event shall there be any refund of any portion of the initial fee for installation of Licensee's System.

6. Scope of License. The license granted to Licensee in this Agreement shall only cover the initial installation of Licensee's System, facilities and related

infrastructure, and any repair to such System. This Agreement shall not entitle Licensee to replace the facilities, to expand the facilities to any additional portions of the City right-of-way beyond those specifically described on Exhibit "A," or to perform any other work or construction activity within the City right-of-way beyond that specifically provided for in this Agreement. Any such additional work beyond that described in this Agreement shall require the negotiation and execution of a new License Agreement between the City and the Licensee.

7. Licensee Contractors. The requirements of this Agreement shall apply to all persons, firms or corporations performing work for the Licensee under a contract, subcontract or other type of work order.

8. Joint Trench/Boring. Before commencement of the work of installation of Licensee's facilities, if Cedar Falls Utilities has notified the City that it desires to relocate any portion of its telecommunications facilities from above-ground infrastructure to underground infrastructure along all or any part of the route described and identified in Exhibit "A" attached hereto, and City has notified Licensee of its desire to cooperate in such construction no later than 30 calendar days after Licensee has submitted its initial construction plans to the City, then Licensee agrees to cooperate with Cedar Falls Utilities to place its fiber optic cable in a joint trench or common boring hole with Cedar Falls Utilities. Licensee agrees to share the cost of such joint trench or common boring with Cedar Falls Utilities on a basis which is fair, reasonable, and competitively neutral and non-discriminatory, as long as the costs of doing so result in overall savings to both Cedar Falls Utilities and Licensee hereunder.

9. Repair Work. Before commencing any repair work to Licensee's System involving any excavation or disturbance of the ground within the City right-of-way, Licensee shall file with the City Public Works Department an application for a permit for such repair work, accompanied by a map, detailed plan or specifications showing the proposed location of the repair work with reference to streets, alleys and the location of other utilities within the right-of-way, the size and dimension of the facilities to which the repair work will be done, and the distance above or beneath the surface of the ground that the proposed repair work will involve. Licensee shall obtain all necessary permits from the City, and pay all necessary permit fees and costs associated therewith, as are provided for by City ordinances, regulations, policies and procedures then in effect. If the proposed repair work shall interfere with the reasonable and proper use of any public improvements or any existing public utility system component or other structure upon or under the public right-of-way, the City shall within thirty (30) days after the filing of such map, plan or specifications, furnish Licensee with the changes necessary to eliminate any interference with a public utility system facility and require Licensee to amend its application for a permit for such repair work. Once such map, plan or specifications have been properly modified to meet the City's reasonable requirements, the City shall issue a permit authorizing Licensee to proceed with the repair work in accordance with the approved map, plan or specifications. No construction shall be commenced by Licensee before issuance of all necessary permits and payment of all

necessary fees, unless the repairs involve emergency repairs, whereupon Licensee shall meet and confer with the City regarding the repair work and the reason for the emergency nature of the repair, unless Licensee is unable to contact the City before the repairs must be done, in which case Licensee shall make only such repairs as are necessary to remove the emergency, and shall notify the City thereof as soon as possible and shall meet and confer with the City in an expeditious manner regarding the nature of the repair work.

10. Relocation at Request of City or City Utilities. In the event that either the City, or its municipal utilities (hereinafter the "City Utilities"), undertakes any construction, reconstruction, repair, replacement, relocation underground, or other modifications to City or City Utilities public infrastructure facilities within the right-of-way, and such undertaking cannot be reasonably be accomplished without the relocation of part or all, as the case may be, of Licensee's System, Licensee shall, upon reasonable notice to Licensee, remove and relocate such part or all of its System, facilities and related infrastructure, and, if requested by the City or the City Utilities, Licensee shall relocate its facilities in a joint trench, joint conduit, or similar joint underground structure, all at Licensee's expense. Licensee shall promptly complete such removal or relocation, and in no event shall Licensee complete such removal or relocation more than 90 days after notice by the City, unless a longer time period is agreed upon in advance by the City in its sole discretion. Licensee shall comply with all provisions of City's ordinances, now existing or hereafter enacted, including without limitation the City's existing underground ordinance. All such costs of relocation of the Licensee's facilities shall be at Licensee's sole cost and expense. In the event Licensee fails to act within a reasonable time to remove and relocate its System, facilities and related infrastructure, the City or the City Utilities may cause such System, facilities and related infrastructure of Licensee to be removed and relocated, and the costs thereof shall be paid by Licensee.

11. Relocation at Request of Other Provider. If a utility provider other than the City or the City Utilities obtains a permit from the City for installation or relocation of its utility facilities within the public right-of-way that reasonably requires the relocation of part or all, as the case may be, of Licensee's facilities, such costs of relocation shall be borne by the other utility provider, not by Licensee or by the City or the City Utilities. Relocation shall be completed as set forth in Section 10.

12. Approval of State of Iowa. In the course of installation of Licensee's facilities, if any approval from the State of Iowa is required, Licensee shall obtain such approval at its sole cost and expense before commencing the work that requires State of Iowa approval.

13. License Complies with Federal and State Law. Licensee specifically agrees that license granted to it under this Agreement does not create an unreasonable barrier to interstate or intrastate commerce, is in accord with the City's right to regulate the use of its public right-of-way in a competitively neutral and non-discriminatory

manner, and that this license complies with all applicable federal and state laws, including without limitation Title 47, United States Code Sections 2153(a) and 253(b).

14. Bond. Licensee shall post a bond with the City in an amount at least equal to the total cost of installation of Licensee's System and all facilities and infrastructure related thereto within the public right-of-way, or the cost of installation of that portion of Licensee's System which its permit covers, whichever is applicable, in a form and of a content reasonably acceptable to City, and in compliance with the City's ordinances, regulations, policies and procedures.

15. Additional Requirements Relative to Installation and Repair Work. In the process of installation of the Licensee's facilities, or the repair of any portion of Licensee's system, any excavation or obstruction made or placed in the public right-of-way at any time or for any purpose by Licensee shall be properly barricaded to comply, at a minimum, with requirements set forth in the Manual on Uniform Traffic Control Devices (MUTCD). Licensee shall provide to the City for the City's approval, prior to commencement of any installation or repair, written plans and specifications which shall include, at a minimum, requirements set forth in the Statewide Urban Design and Specification Program (SUDAS). Any pavement removed or damaged, and all other disturbed areas in the public right-of-way shall be properly and adequately replaced in accordance with the specifications of the City Engineer, all at Licensee's sole cost and expense. Licensee shall at its sole cost and expense repair any private property, public utility system component, public improvement or other public property damaged by Licensee's work, in a manner reasonably acceptable to the City Engineer. If Licensee fails to do such work after seven (7) days' notice in writing to do so from the City, the City may make such repairs at the expense of the Licensee, and Licensee shall pay said costs to City.

16. No Restriction on City Rights. Nothing in this Agreement shall restrict the right of City or the City Utilities to engage in any work within the City right-of-way, whether occupied by Licensee's facilities or otherwise. Without limiting the generality of the foregoing, the City and the City Utilities reserve the right to install any public infrastructure that may be deemed necessary or proper by the City or the City Utilities anywhere within the City right-of-way, whether occupied by Licensee or not. The City may also permit others to install facilities within the public right-of-way and the City shall not be liable to the Licensee for any damages arising out of any work by others.

17. Licensee's Facilities. Licensee's facilities erected by the Licensee within the City right-of-way shall conform to established grades of streets, alleys and sidewalks, and shall be so located as to cause no interference with other public utilities located in or upon the public right-of-way, and to cause no interference with the rights of property owners whose properties adjoin the public right-of-way. Licensee shall not place its facilities anywhere on the public right-of-way where those facilities will interfere with the normal use or maintenance of any public improvement, including but not limited to streets, alleys, sidewalks, traffic control devices, sanitary sewers, storm sewers,

storm drains or water drains, electrical transmission lines, any other public utility facility of the City, the City Utilities or any other public utility provider.

18. Iowa One Call System. Upon request, Licensee agrees to assist the City or others in locating underground facilities which are part of Licensee's system, and to do so in a timely manner but not more than forty-eight (48) hours after the time of request. Licensee agrees to enroll as a member of the "Iowa One Call System," and shall respond to all requests and notifications made to such system.

19. Powers of City. Nothing in this Agreement shall be construed to limit any right or power of the City in any manner whatsoever, whether relating to the City public right-of-way or any other rights and powers of the City. Nothing in this Agreement shall be construed to create a special duty by the City to any owner or operator of a communications system within the right-of-way. Nothing in this Agreement shall be construed to create any property interest or right to occupy space within the right-of-way.

20. Plans and Specifications. Attached hereto, marked "Exhibit "B," are Licensee's approved construction drawings. Upon completion of the installation of Licensee's facilities, Licensee shall promptly furnish to the City complete and accurate copies of "as built" plans and specifications relating to its facilities located within the City right-of-way. Licensee shall keep complete and accurate maps and records of the locations and operations of its facilities and furnish copies thereof to the City upon request.

21. Violations of Agreement.

a. Upon receipt of information by the City that Licensee has violated any term or condition of this Agreement or any provisions of City ordinances, regulations, policies or procedures that regulate Licensee or its use of public right-of-way, the City shall notify Licensee of such violation. If the City determines that a default exists with respect to Licensee's conduct, the City shall notify the Licensee of the default, and the Licensee shall cure such default within ten (10) days of receipt of such notice, provided, however, where the default cannot reasonably be cured within such ten (10)-day period, if Licensee proceeds promptly to begin curing the default with due diligence, the time for curing such default shall be extended for such period of time as is reasonably required for Licensee to completely cure such default.

b. If Licensee fails to cure a default within the ten (10)-day period, or within such reasonable extension of the ten (10)-day period as is required to cure such default, the City shall have any and all rights and remedies afforded by law, including, but not limited to, the right to proceed as follows:

- (1) Declare this Agreement terminated; or

- (2) Seek specific performance; or
- (3) Cure the default of Licensee by correcting the default and charging the reasonable costs or such work to Licensee; or
- (4) Commence litigation for damages for the default; or
- (5) Obtain an injunction against Licensee continuing to operate its facilities covered by this license until such default is remedied; or
- (6) Any combination of the foregoing remedies, or any other remedies afforded at law or in equity.

22. Liability, Indemnification and Insurance. The Licensee covenants to indemnify, defend, and save the City and its officers, agents and employees, and the City Utilities, harmless from any and all damages arising directly from the exercise of the rights granted herein. The Licensee agrees to require contractors and subcontractors engaged in work for the Licensee within the public right-of-ways or on public property to maintain in effect during the term of work liability insurance in comprehensive form and in the amounts determined under the City of Cedar Falls Insurance Requirements for Contractors, as the same may be modified from time to time. Licensee agrees to accept the risk of having its communications systems and equipment upon the public right-of-way, including the possible risk of damage or injury to its system or equipment, and agrees to release and discharge the City and the City Utilities of any liability for damage or injury to Licensee's equipment, except to the extent caused by the City's or the City Utilities' gross negligence. In no event shall the City or the City Utilities be liable for any consequential damages arising out of any damage or injury to Licensee's equipment placed in the right-of-way.

23. Severability. In the event that a court of competent jurisdiction shall adjudge any provision or provisions hereof invalid or illegal, or direct a change by the Licensee in any matter or thing herein contained, such an invalidity or illegality or change shall in no way affect the remaining provisions of this Agreement or their validity or legality, and this Agreement in all other respects shall continue in full force and effect, as if said provision or provisions had not been so adjudged invalid or illegal, or such change had not been directed, or shall at the City's option, cause a termination of this Agreement.

24. Assignment. Licensee shall not assign or otherwise transfer this Agreement or any of the rights granted to Licensee hereunder to any third party without the prior written consent of the City, which consent shall not be unreasonably withheld. In the event Licensee is merged into or consolidated with another entity, or another entity purchases substantially all of the assets of Licensee, then such party into which Licensee is merged or with which Licensee is consolidated or the entity which purchases substantially all of the assets of Licensee shall become the successor to Licensee upon a showing to the reasonable satisfaction of the City that such third party

has the financial capability to perform all of the Licensee's duties and responsibilities provided for in this Agreement, and provided, further, that the rights of Licensee shall not be expanded, increased, or altered by such merger, consolidation or purchase, with such third party being limited to only those rights specifically granted to Licensee pursuant to the terms of this Agreement.

25. Vacation of Public Right-of-Way. As long as Licensee is in compliance with the terms of this Agreement, the City shall not, by ordinance or otherwise, vacate any public rights-of-way in which Licensee has installed its facilities without reserving such rights as may be necessary to allow Licensee the continued use of such property for operation of its facilities in accordance with the terms of this Agreement, provided, however, that nothing in this section shall in any way limit the right of the City to require Licensee to remove and relocate its facilities elsewhere within the public right-of-way as provided for in this Agreement.

26. Transfer of Title. If Licensee abandons its System for a period of twelve (12) months or longer, then at City's option, the City may effectuate a transfer of all Licensee's right, title and interest in and to the System. Abandonment shall be presumed if Licensee has not filed with the office of the City Public Works Department a notice of continued use within thirty (30) days after City's written request for the same, which request shall not be made more than once during any consecutive twelve (12) month period. City shall deliver to Licensee a written notice of City's intent to effectuate a transfer of title, and shall permit Licensee a period of thirty (30) days from the date of the delivery in which to provide written notice of non-abandonment. Absent such action by Licensee, the City may file in the public land record of Black Hawk County, Iowa, a notice of transfer of title. Licensee shall not be entitled to any compensation from the City for a transfer as contemplated by this section.

27. Delivery of Notices. Except as may be expressly provided herein, any notices hereunder shall be in writing and shall be delivered via certified mail and addressed as follows, unless indicated otherwise in the future:

If to the City: City of Cedar Falls, Iowa
Attn: City Clerk
220 Clay Street
Cedar Falls, IA 50613

If to Licensee: Aureon Network Services
Attn: Matthew Weiser
7760 Office Plaza Dr. S
West Des Moines, Iowa 50266

28. Federal, State and Local Laws. This Agreement is subject to all applicable federal, state and local laws, including without limitation, The Communications Act of 1934, as amended, The Telecommunications Act of 1996, as amended, Chapter 480A,

Code of Iowa, and Chapter 27, Utilities, of the Code of Ordinances of the City of Cedar Falls, Iowa.

29. Governing Law; Legal Action. This Agreement shall be governed by and construed in accordance with the laws of the State of Iowa. In any legal proceedings to interpret, construe or enforce this Agreement, the parties hereby agree and consent (a) to irrevocably submit to the jurisdiction and venue of the Iowa District Court in and for Black Hawk County, over any action or proceeding to enforce or defend any matter arising from or related to this Agreement; (b) to irrevocably waive, to the fullest extent a party may effectively do so, the defense of any inconvenient forum to the maintenance of any such action or proceeding; and (c) not to institute any legal action or proceeding against the other party, concerning any matter arising out of or relating to this Agreement, in any court other than the one specified in this section.

30. General Provisions. This Agreement, together with any exhibits referenced herein, together constitute the entire agreement of the parties with respect to the subject matter hereof. It may not be modified or amended except by a written instrument signed by both parties. This Agreement is binding upon the parties and the permitted successors, assigns and transferees of each party.

In witness whereof, this Agreement is entered into effective as the 9th day of December, 2022.

AUREON NETWORK SERVICES
By Scott Behn

CITY OF CEDAR FALLS, IOWA
By _____
Robert M. Green, Mayor

LICENSEE

ATTEST:

Jacqueline Danielsen, MMC, City Clerk

STATE OF Iowa)
COUNTY OF Dallas)

This instrument was acknowledged before me on December 9, 2022,
by Scott Behn, the CEO of Aureon Network Services.

Debra Smith
Notary Public in and for said State



My Commission Expires:

STATE OF IOWA)

COUNTY OF BLACK HAWK)

This instrument was acknowledged before me on _____, 2022, by Robert M. Green, as Mayor, and Jacqueline Danielsen, MMC, as City Clerk, of the City of Cedar Falls, Iowa, an Iowa municipality.

Notary Public in and for said State

My Commission Expires:

EXHIBIT A**TEXT DESCRIPTION OF ALIGNMENT FOR AUREON FIBER OPTIC CABLE INSTALLATION IN CEDAR FALLS**

The facility shall consist of one (1) two (2") inch diameter High-Density Polyethylene (HDPE) duct with 96 count fiber cable installed at minimum depths of: sixty (60") inches below public roadways, forty-eight (48") inches below private driveways, and forty-two (42") inch "plan depths" in grassed areas.

In general terms, within the north right-of-way of W 2nd Street and more particularly described as follows:

1. The facility shall begin at the existing handhole located in the east right-of-way of Franklin Street at a point being thirty-one and a half (31.5') feet easterly of the centerline of Franklin Street at station 200+45 and forty-three (43') feet northerly of the W 2nd Street centerline at station 100+33 also being station 1+00 of the facility alignment as shown on sheet "3 of 6", Project No. 2209627, Exhibit B, a copy of which is attached to this Exhibit A.
2. Thence southeasterly to the north right-of-way of W 2nd Street seventeen and a half (17.5') feet to station 1+17.5 @ 48" min. depth below W 2nd Street to a proposed bore pit as shown on sheet "3 of 6" of said Exhibit B.
3. Thence easterly on the north side of W 2nd Street one-hundred twenty-eight and a half (128.5') feet to station 2+46 @ 48" min. depth and overpass the existing north-south water main by a twenty-four (24") inch minimum as shown on sheet "3 of 6" of said Exhibit B.
4. Thence easterly on the north side of W 2nd Street seventeen (17') feet to station 2+63 @ 48" min. depth below private drive as shown on sheet "3 of 6" of said Exhibit B.
5. Thence easterly on the north side of W 2nd Street one-hundred and seventy-two (172') feet to station 4+35 @ 60" min. depth below Clay Street as shown on sheet "3 of 6" of said Exhibit B.
6. Thence easterly on the north side of W 2nd Street twelve (12') feet to station 4+47 @ 60" min. depth and overpass the existing north-south sanitary sewer by a twenty-four (24") inch minimum as shown on sheet "3 of 6" of said Exhibit B.
7. Thence easterly on the north side of W 2nd Street forty-eight (48') feet @ 48" min. depth to a proposed hand-hole and receiving pit at station 4+77 also being station 104+03, 30.5' Lt of the W 2nd Street alignment and station 300+34, 39.5' Rt of the Clay Street alignment as shown on sheet "3 of 6" of said Exhibit B.
8. Thence easterly on the north side of W 2nd Street one-hundred thirty-eight (138') feet to station 6+13 @ 48" min. depth and overpass the existing north-south water main by a twenty-four (24") inch minimum as shown on sheet "3 of 6" of said Exhibit B.
9. Thence easterly on the north side of W 2nd Street three (3') feet to station 6+16 @ 48" min. depth below 16.5' alley way as shown on sheet "3 of 6" of said Exhibit B.
10. Thence easterly on the north side of W 2nd Street seventeen (17') feet to station 6+33 @ 48" min. depth to a proposed bore pit as shown on sheet "3 of 6" of said Exhibit B.
11. Thence northerly from said bore pit on the north side of W 2nd Street seven (7') feet to the northerly right-of-way of W 2nd Street and being station 105+61 thirty-seven (37') feet Lt of the W 2nd Street centerline alignment and out of City of Cedar Falls right-of-way. Proposed fiber continues north on private property to customer hand-hole as shown on sheet "3 of 6" of said Exhibit B.

EXHIBIT B

NOTES

- CONTACT THE CITY OF CEDAR FALLS DEPARTMENT OF PUBLIC WORKS AT 319-273-8629 AT FORTY-EIGHT (48HRS) HOURS PRIOR TO STARTING CONSTRUCTION.
 - THE WORK CONTRACTOR SHALL NOT ALLOW ANY ENTITIES' VEHICLES THAT ARE, IN ANY WAY, ON SITE BECAUSE OF THE PROJECT WORK, TO BE DRIVEN ON ANY RECREATIONAL TRAIL SECTIONS. ANY AND ALL DAMAGED SECTION(S) SHALL BE REPLACED BY THE CONTRACTOR, TO THE SATISFACTION OF THE CITY ENGINEER, AT NO COST TO THE CITY.
- THE CONTRACTOR SHALL NOT PLACE ANY HANDHOLES IN ANY EXISTING OR PLANNED FUTURE SIDEWALK, HANDICAPPED RAMP OR RECREATIONAL TRAIL..
- THE CONTRACTOR SHALL BORE UNDER ALL EXISTING OR PLANNED FUTURE STREETS, ROADS, DRIVEWAYS, SIDEWALKS AND RECREATIONAL TRAILS, AS PER OTHER NOTES, VARIOUS EXISTING AND PLANNED FUTURE UTILITY INFRASTRUCTURES.
- CONTRACTOR PRACTICES AND ALL FINISHED WORK SHALL CONFORM TO THE CURRENT STATEWIDE URBAN DESIGN AND SPECIFICATIONS (SUDAS) PROGRAM, INCLUDING ALL LOCAL GOVERNMENTAL SUPPLEMENTAL SPECIFICATIONS AND CEDAR FALLS SPECIFICATIONS IN EFFECT WITHIN THE APPLICABLE JURISDICTION. ALL AREAS WHERE WORK IS PERFORMED OR AFFECTED BY THE WORK SHALL BE RETURNED TO A CONDITION EQUAL TO OR BETTER THAN THEIR ORIGINAL CONDITION, THE CEDAR FALLS CITY ENGINEER WILL GIVE FINAL DETERMINATION WHETHER ALL "RETURNED CONDITIONS" ARE EQUAL TO OR BETTER THAN THE ORIGINAL AND ACCEPTABLE.
- THE MINIMUM UNDERCROSSING CLEARANCE AT ALL STORM SEWERS AND STORM SEWER CULVERTS SHALL BE TWENTY-FOUR (24") INCHES. THE MINIMUM UNDERCROSSING CLEARANCE UNDER WATERWAYS SHALL BE THIRTY-SIX (36") INCHES.
- THE CONTRACTOR SHALL MAINTAIN AT LEAST ONE FOOT (1') OF HORIZONTAL CLEARANCE FROM STORM SEWER PIPES AND STRUCTURES WITH THE ALIGNMENT. THE FIBER OPTIC CABLE SHALL ALWAYS BE PLACED BELOW (UNDERPASS) AN EXISTING STORM SEWER OR POSSIBLE FUTURE STORM SEWER BOTTOM OF PIPE ELEVATION BY A MINIMUM CLEARANCE OF 2'
- THE CONTRACTOR SHALL MAINTAIN AT LEAST FOUR FEET (4') OF HORIZONTAL CLEARANCE FROM SANITARY SEWER PIPES AND STRUCTURES WITH THE ALIGNMENT. WHEN A 2' VERTICAL CLEARANCE ABOVE AN EXISTING SANITARY SEWER OR POSSIBLE FUTURE SANITARY SEWER IS IN CONFLICT WITH A MINIMUM DEPTH BELOW GRADE, THE FIBER OPTIC CABLE SHALL BE PLACED BELOW (UNDERPASS) THE SANITARY SEWER BOTTOM OF PIPE ELEVATION BY THE MINIMUM CLEARANCE OF 2'.
- THE CONTRACTOR SHALL MAINTAIN AT LEAST THREE FEET (3') OF HORIZONTAL CLEARANCE AND TWO FEET (2') VERTICAL CLEARANCE FROM WATER MAINS WITH THE ALIGNMENT. WHEN A 2' VERTICAL CLEARANCE ABOVE A WATER MAIN OR SERVICE IS IN CONFLICT WITH A MINIMUM DEPTH BELOW GRADE, THE FIBER OPTIC CABLE SHALL BE PLACED BELOW (UNDERPASS) THE WATER MAIN OR SERVICE BOTTOM OF PIPE ELEVATION BY THE MINIMUM CLEARANCE OF 2'.
- DISTANCES SHOWN ARE APPROXIMATE ONLY. CONTRACTOR SHALL FIELD VERIFY CONDITIONS AND MATERIALS NEEDED PRIOR TO CONSTRUCTION.
- IOWA STATE LAW REQUIRES EXCAVATORS TO NOTIFY IOWA ONE-CALL AT LEAST 48 (FORTY-EIGHT) HOURS PRIOR TO ALL EXCAVATIONS (EXCLUDING SATURDAYS, SUNDAYS, AND LEGAL HOLIDAYS). CONTRACTORS MUST CAREFULLY HAND DIG WITHIN THE 24" SAFETY ZONE WHEN EXPOSING UNDERGROUND UTILITIES. IOWA ONE-CALL DOES NOT MARK ALL PRIVATE UTILITIES.
- THE CONTRACTOR SHALL COMPLY WITH ALL CURRENT AND APPLICABLE OCCUPATIONAL SAFETY AND HEALTH ADMINISTRATION (OSHA), FEDERAL, STATE, AND LOCAL RULES AND REGULATIONS GOVERNING THE SAFETY OF EMPLOYEES AND PROPER MATERIAL HANDLING DURING THE CONSTRUCTION, INSTALLATION, AND RESTORATIONS ON THIS PROJECT.
- WHEN PLOWING/TRENCHING FOR PLACEMENT OF FIBER OPTIC CABLE OR DUCT, A MARKER TAPE SHALL ALSO BE PLACED 18" BELOW EXISTING SURFACE, DIRECTLY ABOVE THE CABLE OR DUCT BEING PLACED.
- NO TRENCH OR EXCAVATION SITE SHALL BE LEFT UNATTENDED AT ANY TIME OR LEFT OPEN OVERNIGHT.
- THE FOLLOWING SPECIAL PROVISIONS SHALL APPLY TO TRAFFIC REGULATIONS DURING THE ENTIRE EXTENT OF THIS PROJECT WORK:
 - THERE SHALL BE AT ALL TIMES ADEQUATE VEHICLE AND PEDESTRIAN ACCESS FOR INGRESS AND EGRESS FOR THE PROPERTIES ADJACENT TO THE PROJECT WORK.
 - DURING NON-WORKING HOURS THE CONTRACTOR SHALL KEEP THE EXISTING TRAFFIC LANES CLEAR FROM INTERFERENCE, INCLUDING ALL APPROACHES AND INTERSECTIONS.
 - IF LANE BLOCKAGE IS UNAVOIDABLE, THE CONTRACTOR SHALL NOTIFY THE CITY ENGINEERING DIVISION, THE CITY MUNICIPAL OPERATIONS AND PROGRAMS DEPARTMENT, POLICE DEPARTMENT, FIRE DEPARTMENT, AMBULANCE SERVICES, SCHOOL BUS GARAGES AND ALL OTHER AGENCIES OPERATIONS AS APPROPRIATE SO THAT THESE AGENCIES MAY PLAN TO RE-ROUTE THEIR VEHICLES AROUND THE CONSTRUCTION WORK ZONE(S).
- FOR ALL PUBLIC RIGHT OF WAY AND PUBLIC PROPERTIES; ALL CONDUITS AND FIBER OPTIC CABLE SHALL BE PLACED AT A MINIMUM DEPTH OF SIXTY (60") INCHES BELOW PUBLIC ROADWAYS AND PUBLIC DITCH LINES, UNLESS OTHERWISE SPECIFIED WITHIN A NOTE PERTAINING TO AN INDIVIDUAL UNIQUE AREA ALONG AN ALIGNMENT ON THIS PLAN VIEW SHEET. ALL CONDUITS AND FIBER OPTIC CABLE SHALL BE PLACED AT A MINIMUM DEPTH OF TWENTY FOUR (24") BELOW PUBLIC STORM SEWERS, PUBLIC SUBDRAINS, PUBLIC CULVERTS, AND /OR PUBLIC WATERWAYS BEING CROSSED. ALL FIBER OPTIC CABLE IN AREAS WITH GRASS COVER SHALL BE PLACED AT A MINIMUM DEPTH OF FORTY-TWO (42") INCHES IN THE PUBLIC RIGHT OF WAY AND AT A MINIMUM DISTANCE OF 2' FROM OTHER UTILITIES, UNLESS OTHERWISE SPECIFIED ON THIS PLAN VIEW SHEET. WHEN A 2' VERTICAL CLEARANCE ABOVE A UTILITY IS IN CONFLICT WITH ANY MINIMUM BURY DEPTH WHETHER IT BE 42" IN GRASSED AREAS, 48" UNDERCROSSING DRIVEWAYS OR 60" UNDERCROSSING STREETS, THE FIBER OPTIC CABLE SHALL UNDERPASS THE UTILITIES BY A MINIMUM CLEARANCE OF 2'.
- PLAN SET / DESIGN DEVELOPMENT BY: CIVIL DESIGN ADVANTAGE-WAYNE HOUSER 515-369-4400
- THE CONTACTS FOR THE CITY OF CEDAR FALLS ENGINEERING DIVISION ARE MATTHEW TOLAN AND DAVE WICKE AT 319-268-5161.
- BACKFILL COMPACTION FOR ALL AREAS EXCAVATED SHALL BE AS PER THE CURRENT IOWA STATEWIDE URBAN DESIGN AND SPECIFICATIONS (SUDAS) AND THE CURRENT CITY OF CEDAR FALLS, IOWA SUPPLEMENTAL SPECIFICATIONS AS FOLLOWS: USE NO MORE THAN EIGHT (8") INCH THICK LIFTS FOR BACKFILL AREAS MORE THAN THREE (3') FEET BELOW THE BOTTOM OF PAVEMENT. USE NO MORE THAN SIX (6") INCH THICK LIFTS FOR BACKFILL AREAS LESS THAN OR EQUAL TO THREE (3') FEET BELOW THE BOTTOM OF PAVEMENT. COMPACTION TO AT LEAST 95% OF STANDARD PROCTOR DENSITY WITHIN RIGHT-OF-WAY. OBTAIN REQUIRED COMPACTION WITHIN A SOIL MOISTURE RANGE OF OPTIMUM TO 4% ABOVE OPTIMUM MOISTURE CONTENT. IN AREAS TO REMAIN UNPAVED, TERMINATE BACKFILL MATERIAL EIGHT (8") INCHES BELOW FINISHED GRADE. USE TOPSOIL FOR THE FINAL EIGHT (8") INCHES ABOVE BACKFILL MATERIAL.

APPROVAL TO CONSTRUCT	
No.	2209.627
Dated	11/28/2022
CITY OF CEDAR FALLS PUBLIC WORKS DEPARTMENT ENGINEERING DIVISION	
By	<i>Matthew Tolan</i>

CEDAR FALLS, IOWA

City of Cedar Falls Notes:
- Contractor required to pothole and spot every utility crossing along alignment

UTILITY PROVIDERS - IOWA ONE CALL DESIGN TICKET #552205859:

MEDIACOM
CONTACT NAME : BRIAN KADNER
CONTACT PHONE: 8455449656
CONTACT EMAIL: BKADNER@MEDIACOMCC.COM

CEDAR FALLS UTILITIES
CONTACT NAME : JERALD LUKENSMEYER
CONTACT PHONE: 3192685330
CONTACT EMAIL: JERALD.LUKENSMEYER@CFUNET.NET

CITY OF CEDAR FALLS
CONTACT NAME : TYLER GRIFFIN
CONTACT PHONE: 3192738600
CONTACT EMAIL: TYLER.GRIFFIN@CEDARFALLS.COM

CENTURYLINK
CONTACT NAME : SADIE HULL
CONTACT PHONE: 9185470147
CONTACT EMAIL: SADIE.HULL@LUMEN.COM

AUREON NETWORK SERVICES
CONTACT NAME : JEFF KLOCKO
CONTACT PHONE: 5158300445
CONTACT EMAIL: JEFF.KLOCKO@AUREON.COM

UTILITY WARNING

ANY UTILITIES SHOWN HAVE BEEN LOCATED FROM MAPS AND RECORDS OBTAINED BY THIS SURVEYOR. THE SURVEYOR MAKES NO GUARANTEE THAT THE UTILITIES SHOWN COMPRISE ALL THE UTILITIES IN THE AREA, EITHER IN SERVICE OR ABANDONED. THE SURVEYOR FURTHER DOES NOT WARRANT THAT THE UTILITIES SHOWN ARE IN THE EXACT LOCATION SHOWN.

PROPOSED:

2" ORANGE CONDUIT = 553' (REFLECTS ESTIMATED VERTICAL AND/ OR CURVED ALIGNMENT SECTION LENGTHS).
HANDHOLES = 1

LEGEND

TELEPHONE PEDESTAL		SIGN		WATERMAIN		STORM SEWER INTAKE	
WATER VALVE		POWER POLE		STORM SEWER		UNDERGROUND CONDUIT	
FIRE HYDRANT		TELEVISION PEDESTAL		SANITARY SEWER		HANDHOLE	
TELEPHONE LINE		SANITARY SEWER MANHOLE		GAS LINE		FIBER OPTIC VAULT	
CABLE TELEVISION LINE		STORM SEWER MANHOLE		ELECTRIC LINE		FIBER OPTIC MANHOLE	
FIBER OPTICS LINE		ROUND STORM SEWER INTAKE		OVERHEAD ELECTRIC LINE			

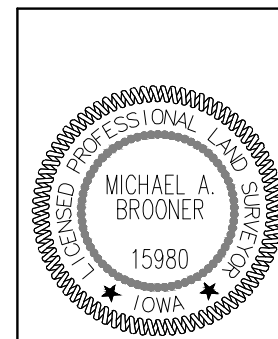

I HEREBY CERTIFY THAT THIS LAND SURVEYING DOCUMENT WAS PREPARED AND THE RELATED SURVEY WORK WAS PERFORMED BY ME OR UNDER MY DIRECT PERSONAL SUPERVISION AND THAT I AM A DULY LICENSED PROFESSIONAL LAND SURVEYOR UNDER THE LAWS OF THE STATE OF IOWA.

9-14-2022
MICHAEL A. BROONER, P.L.S. DATE

MY LICENSE RENEWAL DATE IS DECEMBER 31, 2022
PAGES OR SHEETS COVERED BY THIS SEAL:

SHEETS 1-6

FILE: H:\2022\2209627\DWG\2209627-AUREON-FR-CEDAR FALLS.DWG
PLOTTED BY: WAYNE HOUSER
DATE: 9/14/2022 10:35 AM

REVISIONS
 4121 NW URBANDALE DRIVE
 URBANDALE, IA 50322
 PHONE: (515) 369-4400
AUREON
 CIVIL DESIGN ADVANTAGE
ESA
 CEDAR FALLS, IOWA
AUREON - CEDAR FALLS
 DATE: 09/20/2022
 SHEET NUMBER: 131

EXHIBIT B

SHEET LAYOUT



LENGTH OF UTILITY, IN CEDAR FALLS CITY RIGHT OF WAY	ENDING STA AND OFFSET	BEGINNING STA AND OFFSET	DISTANCE L.F.
BEGINNING @ EXISTING AUREON HH @ NORTHEAST CORNER OF W 2ND STREET & FRANKLIN STREET, SOUTHEAST IN NORTH ROW TO PROPOSED BORE PIT.	100+45 30.5' LT- BP (W 2ND ST. ALIGN)	100+33 43' LT(W 2ND ST. ALIGN)	17.5
FROM PROPOSED BORE PIT @ NORTHEAST CORNER OF W 2ND STREET & FRANKLIN STREET., EAST IN NORTH ROW OF W 2ND STREET, CROSSING CLAY STREET TO HH & REC. PIT.	104+03 30.5' LT- HH & RP (W 2ND ST. ALIGN)	100+45 30.5' LT- BP (W 2ND ST. ALIGN)	357.5
FROM HH & REC. PIT. IN NORTH ROW OF W 2ND STREET, EAST TO BORE PIT.	105+58 30.5' LT- BP (W 2ND ST. ALIGN)	104+03 30.5' LT- HH & RP (W 2ND ST. ALIGN)	158
FROM BORE PIT. IN NORTH ROW OF W 2ND STREET, NORTH OUT OF CITY OF CEDAR FALLS ROW.	105+58 37.5' LT- BP (W 2ND ST. ALIGN)	105+58 30.5' LT- BP (W 2ND ST. ALIGN)	7
TOTAL L.F. OF 2" ORANGE CONDUIT IN CITY OF CEDAR FALLS RIGHT-OF-WAY			540 L.F.

FILE: H:\2022\220927\0\220927-AUREON-FR(CEDAR FALLS).DWG
 PLOTTED BY: ARIANE HOUSER
 DATE: 9/14/2022 10:35 AM
 COMMENT: DWG

Item 16.

NO.	REVISIONS

09/17/2021
FIRST SUBMITTAL

4121 NW URBANDALE DRIVE
 URBANDALE, IA 50322
 PHONE: (515) 369-4400

CIVIL DESIGN ADVANTAGE

CEDAR FALLS, IOWA

AUREON - CEDAR FALLS

DATE: 09/20/2022
 SHEET NUMBER: 132

EXHIBIT B

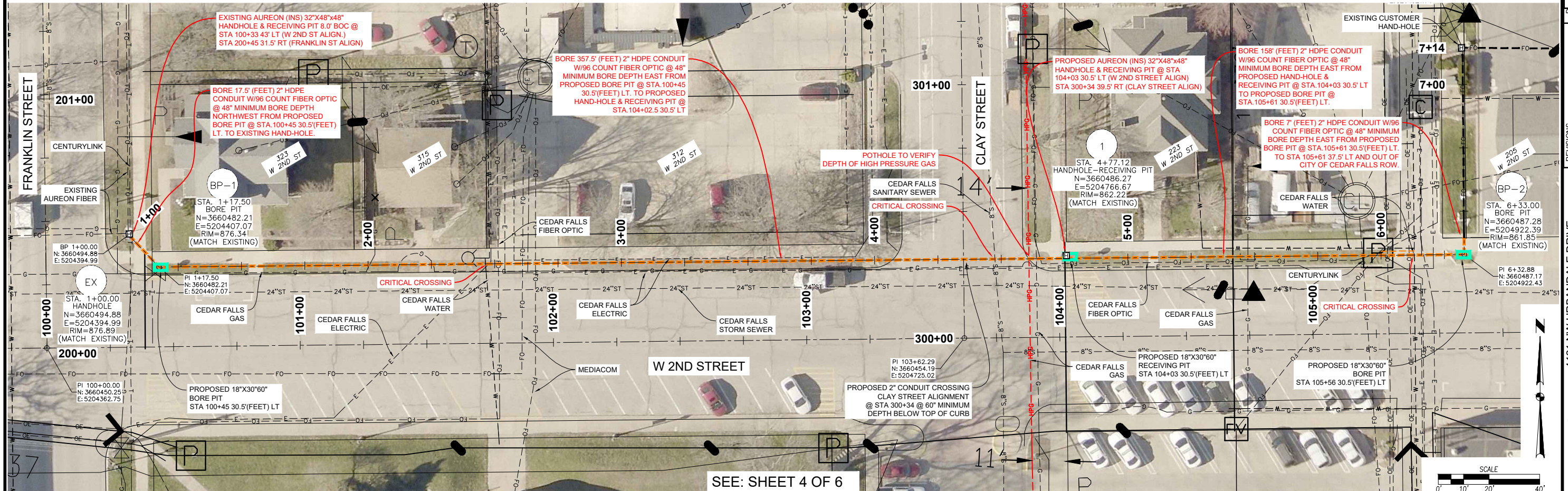

SEE: SHEET 4 OF 6

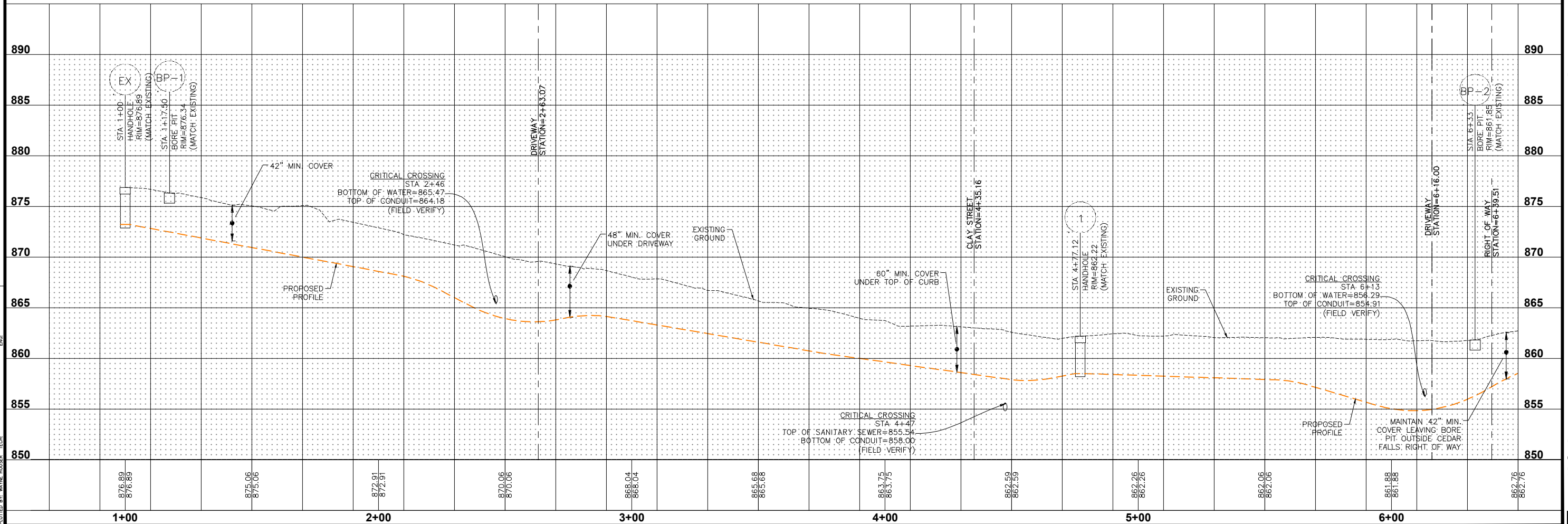

Item 16.

NO.	DESCRIPTION	DATE

REVISIONS

4121 NW URBANDALE DRIVE
URBANDALE, IA 50322
PHONE: (515) 369-4400

AUREON

CIVIL DESIGN ADVANTAGE

DATE: 09/20/2022

SHEET NUMBER: 133

EXHIBIT B

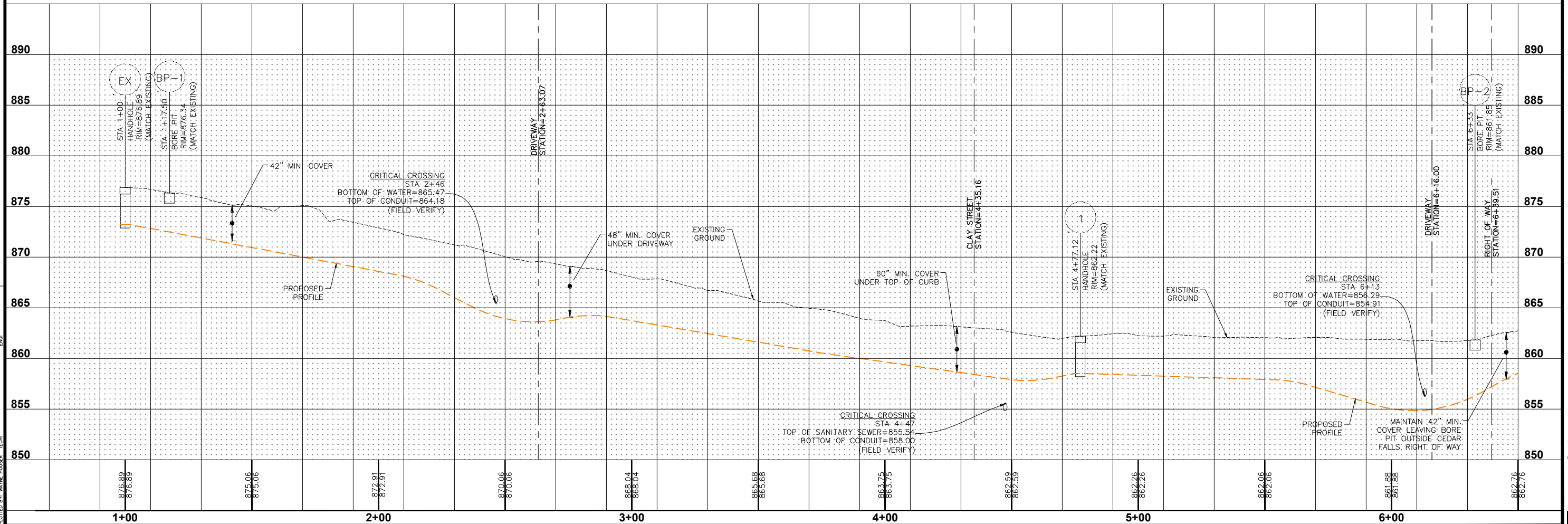
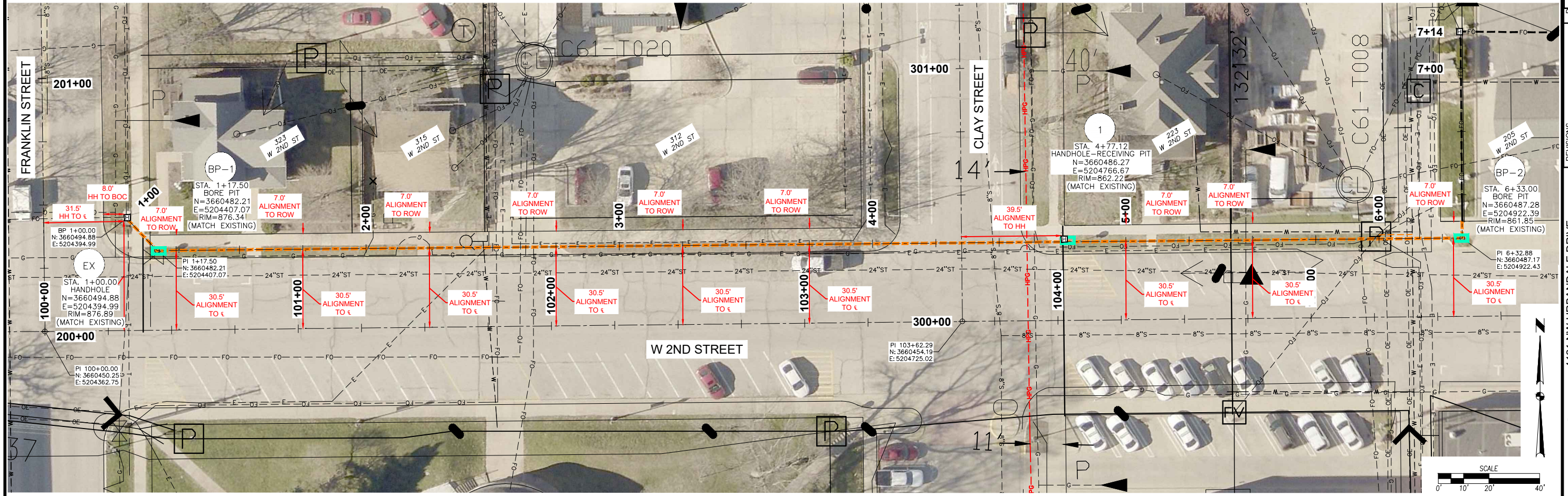

FILE: H:\2022\220927\0\220927-AUREON-FRCDAR-FALLS.DWG
 COMMENT: FRCDAR
 PLOTTED: 9/14/2022 10:36 AM
 DESIGNED BY: AVANE HOUSER

Item 16.

NO.	DATE	DESCRIPTION

4121 NW URBANDALE DRIVE
 URBANDALE, IA 50322
 PHONE: (515) 369-4400



AUREON - CEDAR FALLS
 CEDAR FALLS, IOWA

DATE: 09/20/2022
 SHEET NUMBER: 134

EXHIBIT B

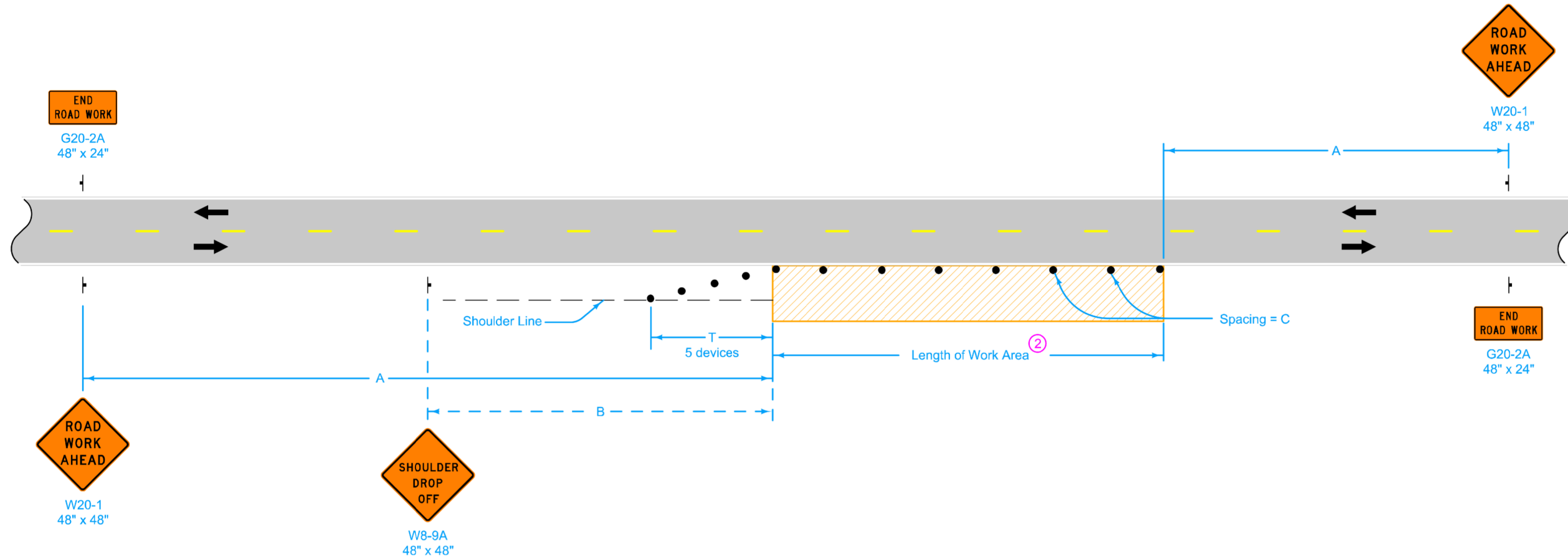

LEGEND

- Traffic Sign
- 42" Channelizer
- Work Area
- Direction of Traffic

SPEED LIMIT (mph)	A	B	C ^②	T
35 or less	500'	250'	40'	100'
40 - 45	700'	350'	80' ^①	200'
50 or greater	1000'	500'	100' ^①	200'

When a pavement edge drop-off exists, install a SHOULDER DROP-OFF sign.

No pavement edge drop-offs greater than pavement depth will be allowed during non-working hours.

Shoulder edge drop-offs shall be mitigated according to Article 1107.08.L2 of the Standard Specifications.

For work lasting less than one hour, refer to TC-1.

- ① When the length of a pavement edge drop-off is 1000 feet or less, the temporary fillet requirement of Article 1107.08 of the Standard Specifications does not apply. Reduce channelizer spacing to 40 feet.
- ② For work areas less than 200 feet long, use channelizers spaced at 20 foot centers or use a vehicle with an amber revolving light or amber strobe light.

Possible Contract Item:
Traffic Control

	REVISION
	8 04-21-15
STANDARD ROAD PLAN	TC-202
SHEET 1 of 1	
<small>REVISIONS: Modified general notes, changed title and replaced the DOT logo in the title block with the new version.</small>	
<small>APPROVED BY DESIGN METHODS ENGINEER</small>	
WORK WITHIN 15 FT OF TRAVELED WAY	

FILE: H:\2022\20220927\W01\20220927-AUREON-FB(CEDAR FALLS).DWG
 PLOTTED BY: WAYNE HOUSER
 DATE: 9/20/2022 10:37 AM
 SCALE: 1"=100'
 SHEET: 136

Item 16.

REVISIONS

4121 NW URBANDALE DRIVE
URBANDALE, IA 50322
PHONE: (515) 369-4400

AUREON
CIVIL DESIGN ADVANTAGE

ESA
CIVIL DESIGN ADVANTAGE

CEDAR FALLS, IOWA

AUREON - CEDAR FALLS

DATE: 09/20/2022
SHEET NUMBER: 136



DEPARTMENT OF PUBLIC WORKS

City of Cedar Falls
 220 Clay Street
 Cedar Falls, Iowa 50613
 Phone: 319-268-5161
 Fax: 319-268-5197
www.cedarfalls.com

MEMORANDUM Engineering Division

TO: Honorable Mayor Robert M. Green and City Council

FROM: Matthew Tolan, EI, Civil Engineer II

DATE: January 9, 2023

SUBJECT: Fiber Optic License Agreement
 Windstream Intellectual Property Services, LLC
 W. 12th Street & Union Road.

Enclosed is a proposed License Agreement between the City of Cedar Falls and Windstream Intellectual Property Services, LLC to install an additional long-distance telecommunications system consisting of fiber optic cable within the public right-of way of the City, in order to extend and upgrade services owned by Windstream intellectual Property Services, LLC along W. 12th Street and Union Road.

The City of Cedar Falls has entered into previous license agreements with other utility services such as Aureon Network Services. The proposed License Agreement follows the terms and conditions set forth in the earlier agreements and is intended to protect the City of Cedar Falls right-of way and manage and regulate in a manner consistent with federal and state law.

The Engineering Division of the Public Works Department recommends your approval of this proposed License Agreement.

xc: David Wicke, PE, City Engineer
 Chase Schrage, Director of Public Works
 Lisa Roeding, Controller/City Treasurer

Prepared by: Matthew Tolan, 220 Clay St., Cedar Falls, IA 50613, (319) 273-8600

LICENSE AGREEMENT

THIS LICENSE AGREEMENT (hereinafter the "Agreement"), is entered into by and between the City of Cedar Falls, Iowa, an Iowa municipality, whose address is 220 Clay Street, Cedar Falls, Iowa 50613 (hereinafter the "City"), and Windstream Intellectual Property Services, LLC., whose address is 1720 Galleria Boulevard, Charlotte, NC 28270, (hereinafter "Licensee").

Whereas, Licensee desires to acquire a license to construct, operate and maintain a certain communications systems within the City, the City is willing to grant such a license on certain terms and conditions, and the parties desire to reduce the agreement to writing.

NOW, THEREFORE, BE IT MUTUALLY COVENANTED AND AGREED BY THE PARTIES AS FOLLOWS:

1. Grant of License. City hereby grants Licensee a non-exclusive, limited license to construct, operate, maintain, inspect and repair a communications system which shall include all equipment owned, operated, leased or subleased in connection with the operation of one (1) fiber optic cable for data transmission and connection starting at the existing over head utility pole that is three hundred and fifty (350') feet south of the centerline of West 12th Street and seventy three (73') feet east of the centerline of Union Road extending four hundred and five (405') northerly then extending twenty-seven (27') feet westerly then extending one hundred thirty one (131') feet northerly then extending seventy-eight (78') feet westerly then extending twenty (20') feet northerly to an existing overhead utility pole that is thirty-two (32') feet west of Union Road centerline and two hundred and six (206') north of the West 12th Street centerline in Cedar Falls, Iowa, including but not limited to poles, pedestals, wires, pipes, cables, underground conduits, ducts, manholes, vaults, fiber optic cables, and other structures, facilities or appurtenances, (hereinafter the "System") within the public right-of-way of the City, as generally depicted on Exhibit "A" attached hereto, and the parties agree that for purposes of this Agreement, the system route consists of approximately 660 linear feet of new fiber optic cables, subject to all rights and powers

of the City under federal and Iowa law and Cedar Falls city ordinances, and subject to the terms and conditions set forth in this Agreement. Licensee acknowledges and understands that this license is non-exclusive, limited and subject to termination as provided in this Agreement. Any connections by Licensee to any other facilities, or to other persons, businesses or entities, shall require an application by Licensee to the City for a separate license within a reasonable time after Licensee furnishes to City all information and documentation in support of Licensee's request for an additional license as may be reasonably required by this form of Agreement or by any ordinance subsequently adopted by the City as described in Section 5.

The facilities shall consist of one (1) two (2") inch High Density Polyethylene ("HDPE") with ninety-six (96) strands of fiber optic cable.

All of the underground cable shall be placed at a minimum depth of 42 inches (42") below ground level, unless approved by Licensor in writing.

Licensee shall obtain all necessary permits from the Iowa Department of Transportation for boring under any state or federal highways along the route, and any necessary consent from other jurisdictions and railroads as necessary for additional boring.

The minimum clearance between the duct and sewers, culverts and/or waterways shall be 36 inches (36").

2. Term of License. The term of the license granted to Licensee hereunder shall commence on the 18th day of January, 2023, and shall continue for a term of one (1) year, or until Licensee has completed the work to install its System, whichever occurs first.

3. License Fee.

a. Licensee shall pay to City an administrative license fee in the amount of \$479.43 payable upon execution of this Agreement, for the rights granted to Licensee as described in this License Agreement. Said license fee shall cover only the fee for the term of this Agreement set forth in Section 2. Licensee agrees that the administrative license fee is the City's estimate of the administrative burdens imposed on the City in connection with Licensee's application and its occupation of the City right-of-way, and Licensee agrees that it will not take any action, nor voluntarily provide support to any third-party action, to challenge the validity or reasonableness of such fee under applicable law. In addition to the administrative fee, Licensee shall pay permit fees and such other regulatory fees as may be required by applicable City ordinance.

b. Thereafter, Licensee shall have an annual license for the continued operation, inspection, maintenance and repair of Licensee's system, for a license fee in the amount of \$47.94 payable by Licensee to the City, for one (1) year

period following the conclusion of the term provided in Section 2, and continuing for succeeding one (1) year terms, until termination of the license as described in Sections 4 or 21 of this Agreement. Licensee agrees that the annual license fee is the City's estimate of the right-of-way management costs imposed on the City in connection with Licensee's occupancy of, and activities in and upon, the City right-of-way, and Licensee agrees that it will not take any action, nor voluntarily provide support to any third-party action, to challenge the validity or reasonableness of such annual license fee under applicable law. The annual license fee shall be payable annually no later than October 1st of each year. In addition to the annual license fee, Licensee shall pay permit fees and such other regulatory fees as may be required by applicable City ordinance. The amount of the annual license fee shall be subject to review and modification based upon the reasonable costs to City to administer and manage Licensee's continued use of the City right-of-way for each succeeding one (1) year term.

4. Removal of Facilities and System. Licensee shall remove its System and all facilities and infrastructure related thereto, upon the occurrence of any one of the following events:

- a. Licensee ceases to do business in the State of Iowa; or
- b. Licensee abandons its System, or discontinues use of the System for a consecutive period of twelve (12) months; or
- c. The end of the economic life of Licensee's System and the need for its replacement; or
- d. Licensee defaults in the performance of its duties and obligations under this Agreement, and fails to timely cure such default as provided in Section 21 of this Agreement.

Upon the happening of any one or more of the following events, Licensee shall promptly, and in no event later than ninety (90) days from the happening, remove its System and all facilities and all related infrastructure from the City right-of-way at Licensee's sole cost.

5. Enactment of City Ordinance. During the term of this Agreement, if the City enacts an ordinance requiring all providers of utilities, telecommunications or other information services to pay a fee to the City on a competitively-neutral and non-discriminatory basis for the use of City right-of-way, Licensee shall comply with the terms and conditions of said ordinance promptly upon enactment of said ordinance. If such ordinance requires annual license fees for the City's continued administration and management of such providers' use of the right-of-way, Licensee shall be entitled to a refund of a pro-rata portion of its annual license fee for the year in which such ordinance is enacted, provided, however, that in no event shall there be any refund of any portion of the initial fee for installation of Licensee's System.

6. Scope of License. The license granted to Licensee in this Agreement shall only cover the initial installation of Licensee's System, facilities and related infrastructure, and any repair to such System. This Agreement shall not entitle Licensee to replace the facilities, to expand the facilities to any additional portions of the City right-of-way beyond those specifically described on Exhibit "A," or to perform any other work or construction activity within the City right-of-way beyond that specifically provided for in this Agreement. Any such additional work beyond that described in this Agreement shall require the negotiation and execution of a new License Agreement between the City and the Licensee.

7. Licensee Contractors. The requirements of this Agreement shall apply to all persons, firms or corporations performing work for the Licensee under a contract, subcontract or other type of work order.

8. Joint Trench/Boring. Before commencement of the work of installation of Licensee's facilities, if Cedar Falls Utilities has notified the City that it desires to relocate any portion of its telecommunications facilities from above-ground infrastructure to underground infrastructure along all or any part of the route described and identified in Exhibit "A" attached hereto, and City has notified Licensee of its desire to cooperate in such construction no later than 30 calendar days after Licensee has submitted its initial construction plans to the City, then Licensee agrees to cooperate with Cedar Falls Utilities to place its fiber optic cable in a joint trench or common boring hole with Cedar Falls Utilities. Licensee agrees to share the cost of such joint trench or common boring with Cedar Falls Utilities on a basis which is fair, reasonable, and competitively neutral and non-discriminatory, as long as the costs of doing so result in overall savings to both Cedar Falls Utilities and Licensee hereunder.

9. Repair Work. Before commencing any repair work to Licensee's System involving any excavation or disturbance of the ground within the City right-of-way, Licensee shall file with the City Public Works Department an application for a permit for such repair work, accompanied by a map, detailed plan or specifications showing the proposed location of the repair work with reference to streets, alleys and the location of other utilities within the right-of-way, the size and dimension of the facilities to which the repair work will be done, and the distance above or beneath the surface of the ground that the proposed repair work will involve. Licensee shall obtain all necessary permits from the City, and pay all necessary permit fees and costs associated therewith, as are provided for by City ordinances, regulations, policies and procedures then in effect. If the proposed repair work shall interfere with the reasonable and proper use of any public improvements or any existing public utility system component or other structure upon or under the public right-of-way, the City shall within thirty (30) days after the filing of such map, plan or specifications, furnish Licensee with the changes necessary to eliminate any interference with a public utility system facility and require Licensee to amend its application for a permit for such repair work. Once such map, plan or specifications have been properly modified to meet the City's reasonable requirements,

the City shall issue a permit authorizing Licensee to proceed with the repair work in accordance with the approved map, plan or specifications. No construction shall be commenced by Licensee before issuance of all necessary permits and payment of all necessary fees, unless the repairs involve emergency repairs, whereupon Licensee shall meet and confer with the City regarding the repair work and the reason for the emergency nature of the repair, unless Licensee is unable to contact the City before the repairs must be done, in which case Licensee shall make only such repairs as are necessary to remove the emergency, and shall notify the City thereof as soon as possible and shall meet and confer with the City in an expeditious manner regarding the nature of the repair work.

10. Relocation at Request of City or City Utilities. In the event that either the City, or its municipal utilities (hereinafter the "City Utilities"), undertakes any construction, reconstruction, repair, replacement, relocation underground, or other modifications to City or City Utilities public infrastructure facilities within the right-of-way, and such undertaking cannot be reasonably be accomplished without the relocation of part or all, as the case may be, of Licensee's System, Licensee shall, upon reasonable notice to Licensee, remove and relocate such part or all of its System, facilities and related infrastructure, and, if requested by the City or the City Utilities, Licensee shall relocate its facilities in a joint trench, joint conduit, or similar joint underground structure, all at Licensee's expense. Licensee shall promptly complete such removal or relocation, and in no event shall Licensee complete such removal or relocation more than 90 days after notice by the City, unless a longer time period is agreed upon in advance by the City in its sole discretion. Licensee shall comply with all provisions of City's ordinances, now existing or hereafter enacted, including without limitation the City's existing underground ordinance. All such costs of relocation of the Licensee's facilities shall be at Licensee's sole cost and expense. In the event Licensee fails to act within a reasonable time to remove and relocate its System, facilities and related infrastructure, the City or the City Utilities may cause such System, facilities and related infrastructure of Licensee to be removed and relocated, and the costs thereof shall be paid by Licensee.

11. Relocation at Request of Other Provider. If a utility provider other than the City or the City Utilities obtains a permit from the City for installation or relocation of its utility facilities within the public right-of-way that reasonably requires the relocation of part or all, as the case may be, of Licensee's facilities, such costs of relocation shall be borne by the other utility provider, not by Licensee or by the City or the City Utilities. Relocation shall be completed as set forth in Section 10.

12. Approval of State of Iowa. In the course of installation of Licensee's facilities, if any approval from the State of Iowa is required, Licensee shall obtain such approval at its sole cost and expense before commencing the work that requires State of Iowa approval.

13. License Complies with Federal and State Law. Licensee specifically agrees that license granted to it under this Agreement does not create an unreasonable

barrier to interstate or intrastate commerce, is in accord with the City's right to regulate the use of its public right-of-way in a competitively neutral and non-discriminatory manner, and that this license complies with all applicable federal and state laws, including without limitation Title 47, United States Code Sections 2153(a) and 253(b).

14. Bond. Licensee shall post a bond with the City in an amount at least equal to the total cost of installation of Licensee's System and all facilities and infrastructure related thereto within the public right-of-way, or the cost of installation of that portion of Licensee's System which its permit covers, whichever is applicable, in a form and of a content reasonably acceptable to City, and in compliance with the City's ordinances, regulations, policies and procedures.

15. Additional Requirements Relative to Installation and Repair Work. In the process of installation of the Licensee's facilities, or the repair of any portion of Licensee's system, any excavation or obstruction made or placed in the public right-of-way at any time or for any purpose by Licensee shall be properly barricaded to comply, at a minimum, with requirements set forth in the Manual on Uniform Traffic Control Devices (MUTCD). Licensee shall provide to the City for the City's approval, prior to commencement of any installation or repair, written plans and specifications which shall include, at a minimum, requirements set forth in the Statewide Urban Design and Specification Program (SUDAS). Any pavement removed or damaged, and all other disturbed areas in the public right-of-way shall be properly and adequately replaced in accordance with the specifications of the City Engineer, all at Licensee's sole cost and expense. Licensee shall at its sole cost and expense repair any private property, public utility system component, public improvement or other public property damaged by Licensee's work, in a manner reasonably acceptable to the City Engineer. If Licensee fails to do such work after seven (7) days' notice in writing to do so from the City, the City may make such repairs at the expense of the Licensee, and Licensee shall pay said costs to City.

16. No Restriction on City Rights. Nothing in this Agreement shall restrict the right of City or the City Utilities to engage in any work within the City right-of-way, whether occupied by Licensee's facilities or otherwise. Without limiting the generality of the foregoing, the City and the City Utilities reserve the right to install any public infrastructure that may be deemed necessary or proper by the City or the City Utilities anywhere within the City right-of-way, whether occupied by Licensee or not. The City may also permit others to install facilities within the public right-of-way and the City shall not be liable to the Licensee for any damages arising out of any work by others.

17. Licensee's Facilities. Licensee's facilities erected by the Licensee within the City right-of-way shall conform to established grades of streets, alleys and sidewalks, and shall be so located as to cause no interference with other public utilities located in or upon the public right-of-way, and to cause no interference with the rights of property owners whose properties adjoin the public right-of-way. Licensee shall not place its facilities anywhere on the public right-of-way where those facilities will interfere with the normal use or maintenance of any public improvement, including but not limited

to streets, alleys, sidewalks, traffic control devices, sanitary sewers, storm sewers, storm drains or water drains, electrical transmission lines, any other public utility facility of the City, the City Utilities or any other public utility provider.

18. Iowa One Call System. Upon request, Licensee agrees to assist the City or others in locating underground facilities which are part of Licensee's system, and to do so in a timely manner but not more than forty-eight (48) hours after the time of request. Licensee agrees to enroll as a member of the "Iowa One Call System," and shall respond to all requests and notifications made to such system.

19. Powers of City. Nothing in this Agreement shall be construed to limit any right or power of the City in any manner whatsoever, whether relating to the City public right-of-way or any other rights and powers of the City. Nothing in this Agreement shall be construed to create a special duty by the City to any owner or operator of a communications system within the right-of-way. Nothing in this Agreement shall be construed to create any property interest or right to occupy space within the right-of-way.

20. Plans and Specifications. Attached hereto, marked "Exhibit B," are Licensee's approved construction drawings. Upon completion of the installation of Licensee's facilities, Licensee shall promptly furnish to the City complete and accurate copies of "as built" plans and specifications relating to its facilities located within the City right-of-way. Licensee shall keep complete and accurate maps and records of the locations and operations of its facilities and furnish copies thereof to the City upon request.

21. Violations of Agreement.

a. Upon receipt of information by the City that Licensee has violated any term or condition of this Agreement or any provisions of City ordinances, regulations, policies or procedures that regulate Licensee or its use of public right-of-way, the City shall notify Licensee of such violation. If the City determines that a default exists with respect to Licensee's conduct, the City shall notify the Licensee of the default, and the Licensee shall cure such default within ten (10) days of receipt of such notice, provided, however, where the default cannot reasonably be cured within such ten (10)-day period, if Licensee proceeds promptly to begin curing the default with due diligence, the time for curing such default shall be extended for such period of time as is reasonably required for Licensee to completely cure such default.

b. If Licensee fails to cure a default within the ten (10)-day period, or within such reasonable extension of the ten (10)-day period as is required to cure such default, the City shall have any and all rights and remedies afforded by law, including, but not limited to, the right to proceed as follows:

- (1) Declare this Agreement terminated; or

- (2) Seek specific performance; or
- (3) Cure the default of Licensee by correcting the default and charging the reasonable costs or such work to Licensee; or
- (4) Commence litigation for damages for the default; or
- (5) Obtain an injunction against Licensee continuing to operate its facilities covered by this license until such default is remedied; or
- (6) Any combination of the foregoing remedies, or any other remedies afforded at law or in equity.

22. Liability, Indemnification and Insurance. The Licensee covenants to indemnify, defend, and save the City and its officers, agents and employees, and the City Utilities, harmless from any and all damages arising directly from the exercise of the rights granted herein. The Licensee agrees to require contractors and subcontractors engaged in work for the Licensee within the public right-of-ways or on public property to maintain in effect during the term of work liability insurance in comprehensive form and in the amounts determined under the City of Cedar Falls Insurance Requirements for Contractors, as the same may be modified from time to time. Licensee agrees to accept the risk of having its communications systems and equipment upon the public right-of-way, including the possible risk of damage or injury to its system or equipment, and agrees to release and discharge the City and the City Utilities of any liability for damage or injury to Licensee's equipment, except to the extent caused by the City's or the City Utilities' gross negligence. In no event shall the City or the City Utilities be liable for any consequential damages arising out of any damage or injury to Licensee's equipment placed in the right-of-way.

23. Severability. In the event that a court of competent jurisdiction shall adjudge any provision or provisions hereof invalid or illegal, or direct a change by the Licensee in any matter or thing herein contained, such an invalidity or illegality or change shall in no way affect the remaining provisions of this Agreement or their validity or legality, and this Agreement in all other respects shall continue in full force and effect, as if said provision or provisions had not been so adjudged invalid or illegal, or such change had not been directed, or shall at the City's option, cause a termination of this Agreement.

24. Assignment. Licensee shall not assign or otherwise transfer this Agreement or any of the rights granted to Licensee hereunder to any third party without the prior written consent of the City, which consent shall not be unreasonably withheld. In the event Licensee is merged into or consolidated with another entity, or another entity purchases substantially all of the assets of Licensee, then such party into which Licensee is merged or with which Licensee is consolidated or the entity which purchases substantially all of the assets of Licensee shall become the successor to

Licensee upon a showing to the reasonable satisfaction of the City that such third party has the financial capability to perform all of the Licensee's duties and responsibilities provided for in this Agreement, and provided, further, that the rights of Licensee shall not be expanded, increased, or altered by such merger, consolidation or purchase, with such third party being limited to only those rights specifically granted to Licensee pursuant to the terms of this Agreement.

25. Vacation of Public Right-of-Way. As long as Licensee is in compliance with the terms of this Agreement, the City shall not, by ordinance or otherwise, vacate any public rights-of-way in which Licensee has installed its facilities without reserving such rights as may be necessary to allow Licensee the continued use of such property for operation of its facilities in accordance with the terms of this Agreement, provided, however, that nothing in this section shall in any way limit the right of the City to require Licensee to remove and relocate its facilities elsewhere within the public right-of-way as provided for in this Agreement.

26. Transfer of Title. If Licensee abandons its System for a period of twelve (12) months or longer, then at City's option, the City may effectuate a transfer of all Licensee's right, title and interest in and to the System. Abandonment shall be presumed if Licensee has not filed with the office of the City Public Works Department a notice of continued use within thirty (30) days after City's written request for the same, which request shall not be made more than once during any consecutive twelve (12) month period. City shall deliver to Licensee a written notice of City's intent to effectuate a transfer of title, and shall permit Licensee a period of thirty (30) days from the date of the delivery in which to provide written notice of non-abandonment. Absent such action by Licensee, the City may file in the public land record of Black Hawk County, Iowa, a notice of transfer of title. Licensee shall not be entitled to any compensation from the City for a transfer as contemplated by this section.

27. Delivery of Notices. Except as may be expressly provided herein, any notices hereunder shall be in writing and shall be delivered via certified mail and addressed as follows, unless indicated otherwise in the future:

If to the City:	City of Cedar Falls, Iowa Attn: City Clerk 220 Clay Street Cedar Falls, IA 50613
-----------------	---

If to Licensee:	Windstream Intellectual Property Services, LLC. 1720 Galleria Boulevard Charlotte, NC 28270
-----------------	---

28. Federal, State and Local Laws. This Agreement is subject to all applicable federal, state and local laws, including without limitation, The Communications Act of 1934, as amended, The Telecommunications Act of 1996, as amended, Chapter 480A,

Joe Malters
Notary Public in and for said State Arkansas

My Commission Expires:
10-6-2023

STATE OF IOWA)
)
COUNTY OF BLACK HAWK)

This instrument was acknowledged before me on _____, 20__,
by Robert M. Green, as Mayor, and Jacqueline Danielsen, MMC, as City Clerk, of the
City of Cedar Falls, Iowa, an Iowa municipality.

Notary Public in and for said State

My Commission Expires:

EXHIBIT A

Description of Route of Windstream Fiber Optic Relocation along the Right Of Way of Union Road

The facility shall consist of one (1) two (2") inch diameter High-Density Polyethylene (HDPE) duct with fiber cable installed at the minimum depths of forty-two (42") inches in grassed areas, forty-eight (48") inches undercrossing driveways and sidewalks, and sixty (60") inches undercrossing streets. This work is to relocate the fiber cable and to transition from overlash to underground installation. The route of the facility shall be as follows:

Right of Way (R.O.W.) of Union Road

Commencing from a point that is 350' south of the C.L. of W. 12 St. and two (2') feet west of the east right of way line of Union Road (+ - 73' east of the Union Rd. CL), thence splicing new fiber into the existing aerial strand on the existing pole, come down existing pole and into a bore pit to a minimum depth of forty-two (42") inches at the beginning location station 0+00, 73' east of the Union Rd. CL.

Thence boring north a distance of two hundred (200') feet (Sta. 2+00, seventy-three (73') feet east of the Union Rd. CL), at a minimum depth of forty-two (42") inches,

Thence boring north a distance of one hundred twenty-four (124') feet (Sta. 3+24, seventy-three (73') feet east of the Union Rd. CL), from a minimum depth of forty-two (42") inches to a minimum depth of sixty (60") inches below the existing CL elevation at the centerline of West 12th St., to the north,

Thence boring north a distance of eighty-one (81') feet (to Sta. 4+05, seventy-three (73') feet east of the Union Rd. CL), at a minimum depth of sixty (60") inches below the existing CL elevation at the centerline of West 12th St., to the north,

Thence boring west twenty-seven (27') feet (to Sta. 4+05, forty-six (46') feet east of the Union Rd. CL, transitioning from a minimum depth of sixty (60") inches below the existing CL elevation at the centerline of West 12th St., to a minimum depth of forty-eight (48") inches,

Thence boring north one-hundred thirty-one (131') feet (to Sta. 56+36, forty-six (46') feet east of the Union Rd. CL, at a minimum depth of forty-eight (48") inches,

Thence boring west seventy-eight (78') feet (to Sta. 5+36, thirty-two (32') feet west of Union Rd. CL) at a minimum depth of sixty (60") inches below the elevation line from the east top of curb to the west top of curb of Union Rd.,

Thence boring north twenty (20') feet (to Sta. 5+56, thirty-two (32') feet west of Union Rd. CL), at a minimum depth of forty-two (42") inches.

VICINITY MAP

Exhibit B

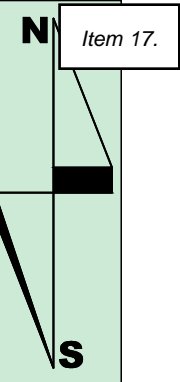

NOTE: ON PLAN SET SUBMITTALS THAT DEPICT BOTH PROPOSED UNDERGROUND AND OVERHEAD INSTALLATIONS WITH ALL STARTING POINTS AND ALL ENDING POINTS FULLY SHOWN AND DESCRIBED, CONDITIONAL APPROVAL OF ALL UNDERGROUND WORK CAN BE GIVEN BY THE CITY ENGINEERING DIVISION AFTER REVIEW ITEMS, RELATING TO UNDERGROUND INSTALLATIONS ONLY, ARE PROPERLY ADDRESSED EXCLUDING TRANSITION OF OVERLASH OR ABOVE GROUND INSTALLATIONS ON POLES IS AT THE DISCRETION OF CEDAR FALLS UTILITIES (CFU). SUBMIT A POLE STUDY TO CFU FOR ADDITIONAL LOADING. CONTACT JOHN OSTERHAUS AT THE CEDAR FALLS UTILITIES (CFU) ELECTRIC DIVISION AT (319) 268-5298

APPROVAL TO CONSTRUCT

No. 707402475

Dated 12/14/2022

CITY OF CEDAR FALLS
PUBLIC WORKS DEPARTMENT
ENGINEERING DIVISION

By *Matthew Tolun*

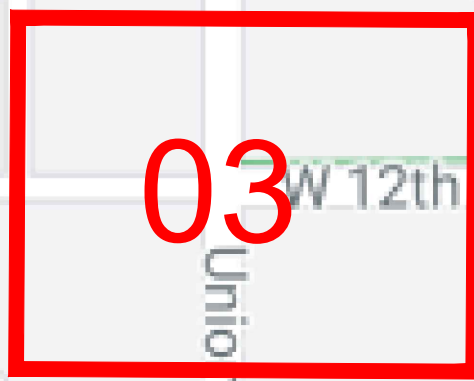

DISCLAIMER:
UTILITY LOCATIONS SHOWN ON THIS DRAWING ARE APPROXIMATE AND SHOULD NOT BE SOLELY RELIED UPON TO LOCATE UNDERGROUND FACILITIES. THE CONTRACTOR SHALL BE FULLY RESPONSIBLE FOR COMPLIANCE WITH STATEWIDE AND/OR LOCAL AREA "ONE CALL" PROGRAMS AND REQUIREMENTS.

CALL BEFORE DIGGING
UTILITY NOTIFICATION CENTER OF IOWA
811- 1-800-292-898

FOR ALL PUBLIC RIGHT OF WAY AND PUBLIC PROPERTIES; ALL CONDUITS AND FIBER OPTIC CABLE SHALL BE PLACED AT A MINIMUM DEPTH OF:

- A) SIXTY (60") INCHES BELOW A LINE FROM SIX(6") INCHES ABOVE STREET GUTTER TO SIX(6") INCHES ABOVE STREET GUTTER ON PUBLIC STREETS AND FOR ALLEYS, BELOW THE CROSS SECTION LOW POINT OF ALLEYS, FOR THE ENTIRE ALLEY WIDTH,
- B) FORTY-EIGHT (48") INCHES BELOW ALL DRIVEWAYS, RECREATIONAL TRAILS, SIDEWALKS, AND LONGITUDINAL RURAL DITCH LINES IN THE PUBLIC RIGHT OF WAY,
- C) FORTY-TWO (42") IN THE GRASSED, SUBURBAN SECTION, PUBLIC RIGHT OF WAY,
- D) TWELVE (12") INCHES BELOW PUBLIC STREET LONGITUDINAL SUBDRAINS,
- E) TWENTY FOUR (24") INCHES BELOW PUBLIC STORM SEWERS, PUBLIC CULVERTS, AND/OR PUBLIC WATERWAY FLOW LINE(S) BEING CROSSED, AND
- F) AT A MINIMUM CLEARANCE DISTANCE OF TWO (2') FEET FROM ELECTRICAL UTILITIES AND ONE AND ONE HALF (1 1/2') FEET FROM ALL OTHER UTILITIES.

(ALL DIMENSIONS APPLY, UNLESS OTHERWISE SPECIFIED ON AN INDIVIDUAL PLAN VIEW, INDIVIDUAL PLAN AND PROFILE VIEW OR INDIVIDUAL PROFILE VIEW SHEET OF THE PLAN SET.)

TABULATION OF UTILITIES		
COMPANY	CONTACT NAME	TELEPHONE
MEDIACOM	KEVIN PARKER	319-240-4937
CEDAR FALLS UTILITIES	JERALD LUKENSMEYER	319-268-5330
CENTURYLINK	BRENT GIESE	563-355-2592
IOWA COMMUNICATIONS NETWORK	SHANNON MARLOW	800-572-3940
WINDSTREAM COMMUNICATIONS	FELICIA HODGES	501-748-4743

ADDRESS: W 12TH ST & UNION RD, CEDAR FALLS, IA 50613
BLACK HAWK COUNTY, IA
PERMIT REQUIRED- CITY
LOCATE ALL FACILITIES PRIOR TO DIGGING
IA - IOWA ONE CALL - 811 - 1-800-292-898

SCALE: NTS



ENGINEER: **WINDSTREAM** - STEPHEN KNESS
FIELD ENGINEER: **PEARCE SERVICES** TROY OZBUN
DRAWN BY: **PEARCE SERVICES** RACHITA SHARMA

PROJECT: 707402475
EXCHANGE: CDFLIA
SHEET: 01 OF 10
DATE: 07/15/2021



UNIT SUMMARY

LEGEND

EXCHANGE	CDFLIA	W.O. # 707402475
W.O.TITLE	RM CDFLIA W 12TH ST & UNION RD	
	SHEET # 03	TOTAL
UNIT CODE:	EST. QUANTITY	EST. QUANTITY
BFO288I	806	806
BM60(1)(2)>100	493	493
XXCO	419	419
BM73	40	40
WHO1(A)	576	576
HOMW(A)	576	576
HAPO(288)	2	2
BM80	2	2
PM92	2	2
PM2A	2	2
PF1-5A	2	2
PE1-3	2	2
BM80PF	4	4
BM81PF	2	2
BM53F	2	2

	CENTER LINE
	BACK OF CURB
	ROW LINE
	SIDEWALK
	NEW CONST. LINES
	WATER LINE
	COMMUNICATIONS (BUR)
	ELECTRICAL (BUR)
	STORM DRAIN
	SANITARY LINE
	TO BE REMOVED (FOC)
	EXISTING CONDUIT
	PROPOSED FIBER (BUR)
	PROPOSED CONDUIT
	COMMS PEDESTAL
	FIBER MARKER
	PROPOSED HANDHOLE
	GROUND ROD
	SLACK FOC LOOP
	PROPOSED BORE PIT
	CATCH BASIN
	TEL/ELEC POLE

FOR ALL PUBLIC RIGHT OF WAY AND PUBLIC PROPERTIES; ALL CONDUITS AND FIBER OPTIC CABLE SHALL BE PLACED AT A MINIMUM DEPTH OF:

- A) SIXTY (60") INCHES BELOW A LINE FROM SIX(6") INCHES ABOVE STREET GUTTER TO SIX(6") INCHES ABOVE STREET GUTTER ON PUBLIC STREETS AND FOR ALLEYS, BELOW THE CROSS SECTION LOW POINT OF ALLEYS, FOR THE ENTIRE ALLEY WIDTH,
- B) FORTY-EIGHT (48") INCHES BELOW ALL DRIVEWAYS, RECREATIONAL TRAILS, SIDEWALKS, AND LONGITUDINAL RURAL DITCH LINES IN THE PUBLIC RIGHT OF WAY,
- C) FORTY-TWO (42") IN THE GRASSED, SUBURBAN SECTION, PUBLIC RIGHT OF WAY,
- D) TWELVE (12") INCHES BELOW PUBLIC STREET LONGITUDINAL SUBDRAINS,
- E) TWENTY FOUR (24") INCHES BELOW PUBLIC STORM SEWERS, PUBLIC CULVERTS, AND/OR PUBLIC WATERWAY FLOW LINE(S) BEING CROSSED, AND
- F) AT A MINIMUM CLEARANCE DISTANCE OF TWO (2') FEET FROM ELECTRICAL UTILITIES AND ONE AND ONE HALF (1 1/2) FEET FROM ALL OTHER UTILITIES.

(ALL DIMENSIONS APPLY, UNLESS OTHERWISE SPECIFIED ON AN INDIVIDUAL PLAN VIEW, INDIVIDUAL PLAN AND PROFILE VIEW OR INDIVIDUAL PROFILE VIEW SHEET OF THE PLAN SET.)

ADDRESS: W 12TH ST & UNION RD, CEDAR FALLS, IA 50613
 BLACK HAWK COUNTY, IA
 PERMIT REQUIRED- CITY
LOCATE ALL FACILITIES PRIOR TO DIGGING
IA - IOWA ONE CALL - 811 - 1-800-292-898

SCALE: NTS



ENGINEER: WINDSTREAM - STEPHEN KNESS
 FIELD ENGINEER: PEARCE SERVICES TROY OZBUN
 DRAWN BY: PEARCE SERVICES RACHITA SHARMA

PROJECT: 707402475

EXCHANGE: CDFLIA
 SHEET: 02 OF 10

DATE: 07/15/2021



FOLLOW BELOW SECTION LENGTH AND SECTION DEPTH AS FOLLOW:-
 1. STA. 0+00, 73' RT. TO STA. 2+50, 73' RT., BORE 250' OF 2" DUCT @MIN. 48" DEPTH FROM THE RISER POLE TO BEGINNING OF DEPTH INCREASE VERTICAL CURVE.
 2. STA. 2+50, 73' RT. TO STA. 4+06, 73' RT., BORE 156' OF 2" DUCT @ DEPTH INCREASE FROM MIN. 48" DEPTH TO MIN. 54" DEPTH BELOW EDGES OF W. 12TH ST. PAVEMENT & TO 54" DEPTH BORE PIT FOR 4' DIA. TIGHT RADIUS BEND TO THE WEST.
 3. STA. 4+06, 73' RT. TO STA. 4+06, 46' RT., BORE 27' OF 2" DUCT @MIN. 48" DEPTH TO 54" DEPTH RECEIVER PIT FOR 4' DIA. TIGHT RADIUS BEND TO THE NORTH.
 4. STA. 4+06, 46' RT. TO STA. 5+36, 46' RT., BORE 130' OF 2" DUCT @ MIN.48" DEPTH TO 54" DEPTH BORE PIT FOR 4' DIA. TIGHT RADIUS BEND TO THE WEST.
 5. STA. 5+36, 46' RT. TO STA. 5+36, 32' LT., BORE 78' OF 2" DUCT @MIN. 60" DEPTH BELOW A LINE FROM SIX(6") INCHES ABOVE STREET GUTTER TO SIX (6") INCHES ABOVE STREET GUTTER OF UNION ROAD TO RECEIVING PIT.

SHEET SUMMARY #3	
PF1-5A	2
BM60(1)(2)	493
BFO288I	806
PE1-3	2
BM80	2
BM53FI	2
WHO1(A)	576
PM92	2
HAPO(288)	2
HOMW(A)	576
BM73	40
FXXCO	491

FOR ALL PUBLIC RIGHT OF WAY AND PUBLIC PROPERTIES; ALL CONDUITS AND FIBER OPTIC CABLE SHALL BE PLACED AT A MINIMUM DEPTH OF:
 A) SIXTY (60") INCHES BELOW A LINE FROM SIX(6") INCHES ABOVE STREET GUTTER TO SIX(6") INCHES ABOVE STREET GUTTER ON PUBLIC STREETS AND FOR ALLEYS, BELOW THE CROSS SECTION LOW POINT OF ALLEYS, FOR THE ENTIRE ALLEY WIDTH,
 B) FORTY-EIGHT (48") INCHES BELOW ALL DRIVEWAYS, RECREATIONAL TRAILS, SIDEWALKS, AND LONGITUDINAL RURAL DITCH LINES IN THE PUBLIC RIGHT OF WAY,
 C) FORTY-TWO (42") IN THE GRASSED, SUBURBAN SECTION, PUBLIC RIGHT OF WAY,
 D) TWELVE (12") INCHES BELOW PUBLIC STREET LONGITUDINAL SUBDRAINS,
 E) TWENTY FOUR (24") INCHES BELOW PUBLIC STORM SEWERS, PUBLIC CULVERTS, AND/OR PUBLIC WATERWAY FLOW LINE(S) BEING CROSSED, AND
 F) AT A MINIMUM CLEARANCE DISTANCE OF TWO (2') FEET FROM ELECTRICAL UTILITIES AND ONE AND ONE HALF (1 1/2) FEET FROM ALL OTHER UTILITIES.
 (ALL DIMENSIONS APPLY, UNLESS OTHERWISE SPECIFIED ON AN INDIVIDUAL PLAN VIEW, INDIVIDUAL PLAN AND PROFILE VIEW OR INDIVIDUAL PROFILE VIEW SHEET OF THE PLAN SET.)

NOTE: CUT 100' OF EXISTING FIBER FOR NEW SPLICE

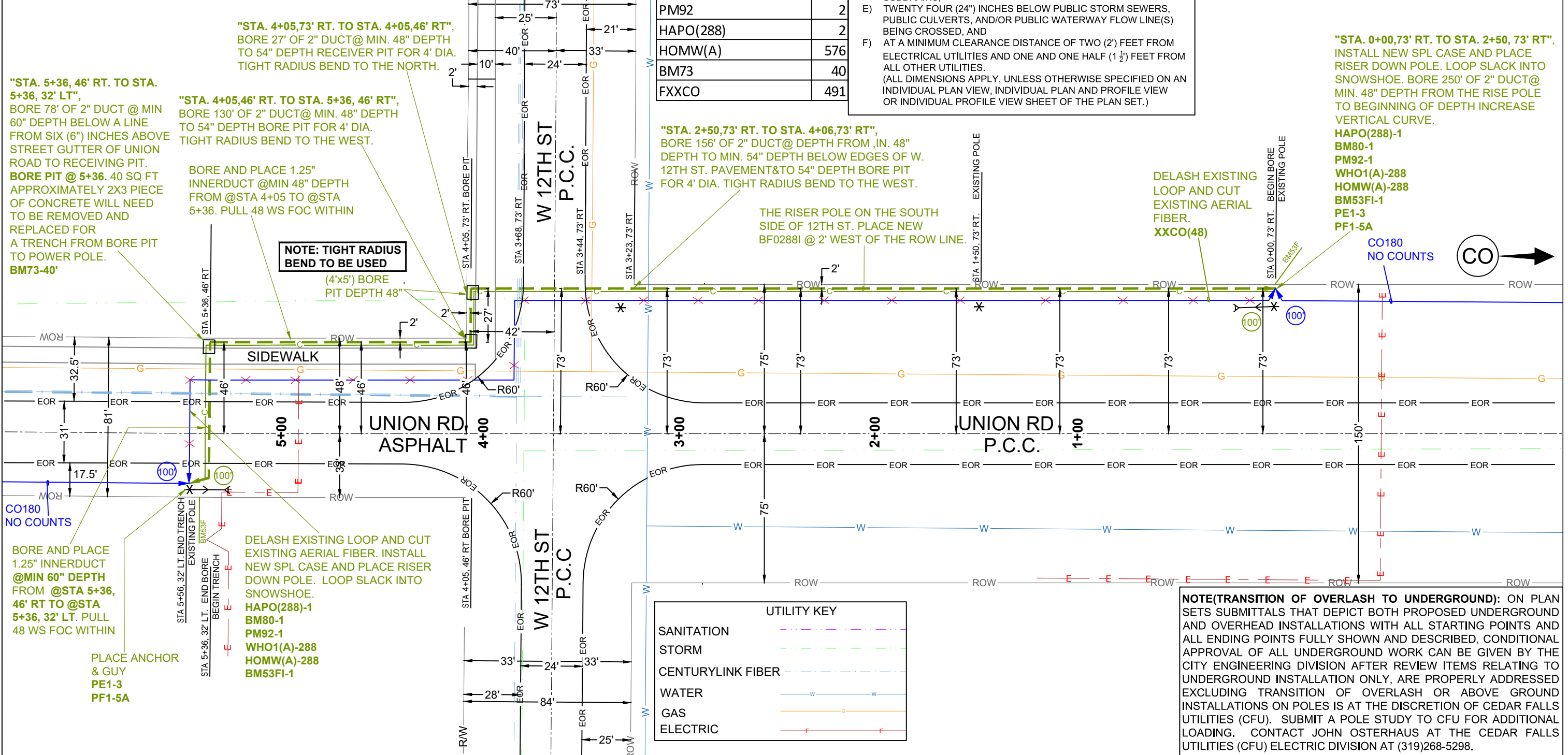

ADDRESS: W 12TH ST & UNION RD, CEDAR FALLS, IA 50613
 BLACK HAWK COUNTY, IA
 PERMIT REQUIRED- CITY
LOCATE ALL FACILITIES PRIOR TO DIGGING
 IA - IOWA ONE CALL - 811 - 1-800-292-898

SCALE: 1:50



ENGINEER: WINDSTREAM - STEPHEN KNESS
 FIELD ENGINEER: PEARCE SERVICES TROY OZBUN
 DRAWN BY: PEARCE SERVICES RACHITA SHARMA

PROJECT: 707402475
 EXCHANGE: CDFLIA
 SHEET: 03 OF 10
 DATE: 07/15/2021



BORE PROFILES

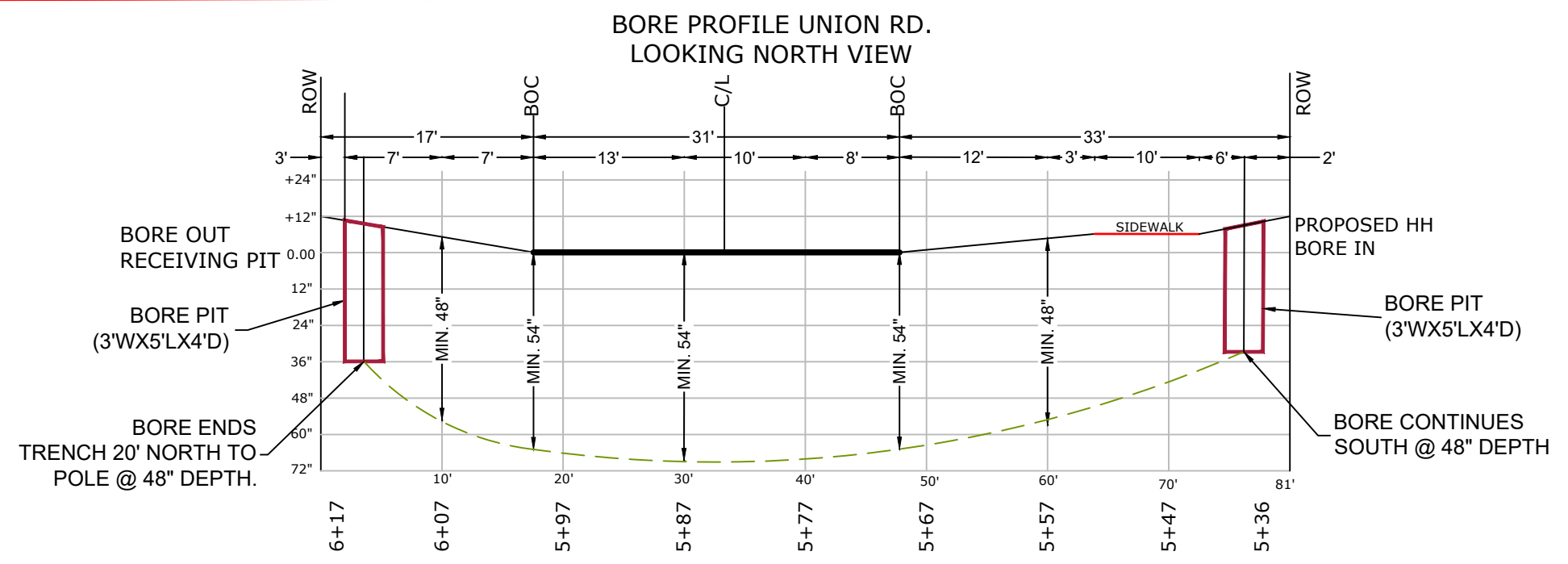

ADDRESS: W 12TH ST & UNION RD, CEDAR FALLS, IA 50613
 BLACK HAWK COUNTY, IA
 PERMIT REQUIRED- CITY
LOCATE ALL FACILITIES PRIOR TO DIGGING
 IA - IOWA ONE CALL - 811 - 1-800-292-898

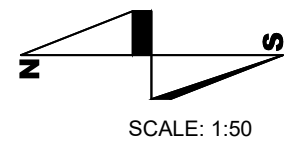

ENGINEER: **WINDSTREAM** - STEPHEN KNESS
 FIELD ENGINEER: **PEARCE SERVICES** TROY OZBUN
 DRAWN BY: **PEARCE SERVICES** RACHITA SHARMA

PROJECT: 707402475
 EXCHANGE: CDFLIA
 SHEET: 04 OF 10
 DATE: 07/15/2021



PLAN NOTES:

1. THE CONTRACTOR SHALL COMPLY WITH ALL COMPANY POLICIES AND PROCEDURES AND ALL REQUIREMENTS FROM LOCAL PERMITTING AUTHORITIES. THE VARIOUS PERMITS OBTAINED FOR THE PROJECT WILL BE ON FILE IN THE OFFICE OF THE WINDSTREAM ENGINEER AND A COPY SHALL BE AVAILABLE AT ALL TIMES AT THE CONSTRUCTION SITE. NO CONSTRUCTION, EXCAVATION OR IMPROVEMENTS OF ANY KIND SHALL BEGIN ON THE SURFACE, IN THE SUBSURFACE OR ABOVE THE SURFACE WITHOUT A SIGNED PERMIT FROM THE GOVERNING PERMIT AUTHORITY OF AUTHORITIES.
2. CONTRACTOR PRACTICES AND ALL FINISHED WORK SHALL CONFORM TO THE CURRENT STATEWIDE URBAN DESIGN AND SPECIFICATIONS (SUDAS) PROGRAM, INCLUDING ALL LOCAL GOVERNMENTAL SUPPLEMENTAL SPECIFICATIONS AND CEDAR FALLS SPECIFICATIONS IN EFFECT WITHIN THE APPLICABLE JURISDICTION. ALL AREAS WHERE WORK IS PERFORMED OR AFFECTED BY THE WORK SHALL BE RETURNED TO A CONDITION EQUAL TO OR BETTER THAN THEIR ORIGINAL CONDITION. THE CEDAR FALLS CITY ENGINEER WILL GIVE FINAL DETERMINATION WHETHER ALL "RETURNED CONDITIONS" ARE EQUAL TO OR BETTER THAN THE ORIGINAL (AND ACCEPTABLE).
3. MISCELLANEOUS STRUCTURES AND OBSTRUCTIONS SUCH AS SIGN POSTS, MAIL BOXES, METER BOXES, ETC., SHALL BE AVOIDED OR REMOVED AND REINSTALLED TO A CONDITION EQUAL TO OR BETTER THAN THEIR ORIGINAL CONDITION. THE CEDAR FALLS CITY ENGINEER WILL GIVE FINAL DETERMINATION WHETHER ALL RETURNED CONDITIONS ARE EQUAL TO OR BETTER THAN THE ORIGINAL.
4. THE CONTRACTOR SHALL BE RESPONSIBLE AT ALL TIMES FOR THE MAINTENANCE OF STREETS AND OTHER UTILITIES AFFECTED BY CONSTRUCTION OPERATIONS. DEBRIS SHALL NOT BE PERMITTED TO ACCUMULATE AND ALL PREMISES SHALL BE MAINTAINED IN A NEAT AND WORKMANLIKE CONDITION. THE CITY ENGINEER OF THE CITY OF CEDAR FALLS WILL REVIEW ALL PROPOSED DISPOSAL SITES, PRIOR TO THEIR USE, TO DETERMINE ACCEPTABILITY.
5. THE CONTRACTOR SHALL TAKE ADEQUATE PRECAUTIONS TO PROTECT EXISTING FACILITIES, SIDEWALKS, CURBS, PAVEMENTS, UTILITIES, FOLIAGE AND ADJOINING PROPERTY AND STRUCTURES OUTSIDE OF RIGHT-OF-WAY AND TO AVOID DAMAGE THERETO.
6. THE FOLLOWING SPECIAL PROVISIONS SHALL APPLY TO TRAFFIC REGULATIONS DURING THE ENTIRE EXTENT OF THIS PROJECT WORK:
 - A. THERE SHALL BE AT ALL TIMES ADEQUATE VEHICLE AND PEDESTRIAN ACCESS FOR INGRESS AND EGRESS FOR THE PROPERTIES ADJACENT TO THE PROJECT WORK.
 - B. DURING NON-WORKING HOURS THE CONTRACTOR SHALL KEEP THE EXISTING TRAFFIC LANES CLEAR FROM INTERFERENCE, INCLUDING ALL APPROACHES AND INTERSECTIONS.
 - C. IF LANE BLOCKAGE IS UNAVOIDABLE, THE CONTRACTOR SHALL NOTIFY THE CITY TRAFFIC ENGINEERING DEPARTMENT, POLICE DEPARTMENT, FIRE DEPARTMENT, AMBULANCE SERVICES, SCHOOL BUS GARAGES, AND ALL OTHER AGENCIES OPERATIONS AS APPROPRIATE SO THAT THESE AGENCIES MAY PLAN TO RE-ROUTE THEIR VEHICLES AROUND THE CONSTRUCTION WORK ZONE(S).
7. WHERE HAZARDOUS CONDITIONS EXIST, PROPER SIGNING, FLAGGING, AND BARRICADING SHALL BE PROVIDED AS DIRECTED BY THE WINDSTREAM ENGINEER OR THE CEDAR FALLS CITY ENGINEER. SUPPLEMENTAL SIGNS, FLAG PERSON(S) AND BARRICADES SHALL BE PROVIDED BY THE CONTRACTOR. NO TRENCH OR EXCAVATION SITE SHALL BE LEFT UNATTENDED, AT ANY TIME, OR OPEN OVERNIGHT.
8. TRENCHES IN PAVED AREAS SHALL BE SAW CUT TO THE FULL DEPTH OF THE PAVEMENT AS REQUIRED BY THE PERMITTING AUTHORITY. PAVED SURFACES SHALL BE REPAIRED IN ACCORDANCE WITH THE PERMITTING AUTHORITY'S SPECIFICATIONS (CURRENT SUDAS) AND THE CURRENT SUPPLEMENTAL SPECIFICATIONS TO THEM.
9. THE CONTRACTOR SHALL COMPLY WITH ALL CURRENT AND APPLICABLE OCCUPATIONAL SAFETY AND HEALTH ADMINISTRATION (OSHA), FEDERAL, STATE, AND LOCAL RULES AND REGULATIONS GOVERNING THE SAFETY OF EMPLOYEES AND PROPER MATERIAL HANDLING DURING THE CONSTRUCTION, INSTALLATION, AND/OR RESTORATIONS ON THIS PROJECT.
10. RIGHT OF WAY RESTORATION AND STREET/SIDEWALK REPAIR/REPLACEMENT SHALL BE IN COMPLIANCE WITH THE LOCAL PERMITTING AUTHORITY.
11. FOR ALL PUBLIC RIGHT OF WAY AND PUBLIC PROPERTIES; ALL CONDUITS AND FIBER OPTIC CABLE SHALL BE PLACED AT A MINIMUM DEPTH OF:
 - A. SIXTY (60") INCHES BELOW A LINE FROM SIX(6") INCHES ABOVE STREET GUTTER TO SIX(6") INCHES ABOVE STREET GUTTER ON PUBLIC STREETS AND FOR ALLEYS, BELOW THE CROSS SECTION LOW POINT OF ALLEYS, FOR THE ENTIRE ALLEY WIDTH,
 - B. FORTY-EIGHT (48") INCHES BELOW ALL DRIVEWAYS, RECREATIONAL TRAILS, SIDEWALKS, AND LONGITUDINAL RURAL DITCH LINES IN THE PUBLIC RIGHT OF WAY,
 - C. FORTY-TWO (42") IN THE GRASSED, SUBURBAN SECTION, PUBLIC RIGHT OF WAY,
 - D. TWELVE (12") INCHES BELOW PUBLIC STREET LONGITUDINAL SUBDRAINS,
 - E. TWENTY FOUR (24") INCHES BELOW PUBLIC STORM SEWERS, PUBLIC CULVERTS, AND/OR PUBLIC WATERWAY FLOW LINE(S) BEING CROSSED, AND
 - F. AT A MINIMUM CLEARANCE DISTANCE OF TWO (2') FEET FROM ELECTRICAL UTILITIES AND ONE AND ONE HALF (1 ½) FEET FROM ALL OTHER UTILITIES.

(ALL DIMENSIONS APPLY, UNLESS OTHERWISE SPECIFIED ON AN INDIVIDUAL PLAN VIEW, INDIVIDUAL PLAN AND PROFILE VIEW OR INDIVIDUAL PROFILE VIEW SHEET OF THE PLAN SET.)
12. FOR ALL DITCHLINES AND PRIVATE DRIVEWAYS, ALL CABLES SHALL BE PLACED AT A MINIMUM DEPTH OF FORTY-EIGHT (48") INCHES BELOW ALL DITCHLINES AND PRIVATE DRIVEWAYS.
13. INNERDUCTS CONTAINING CABLE SHALL BE SEALED AT TERMINATION POINTS USING RUBBER PLUGS AND COMPRESSION BANDS. VACANT INNERDUCTS OR CONDUIT RUNS SHALL BE SEALED AT TERMINATION POINTS WITH RUBBER PLUGS EQUIPPED WITH A PULL LINE ATTACHMENT RING ON WHICH TO TERMINATE THE PULL LINE. APPROPRIATE SEALANT COMPOUND SHALL BE USED TO SEAL ANY GAPS.
14. WHEN PLOWING/TRENCHING FOR PLACEMENT OF FIBER OPTIC CABLE OR DUCT OR ANY OTHER INSTALLATION, A MARKER TAPE SHALL BE PLACED EIGHTEEN (18") INCHES BELOW EXISTING SURFACE OR BELOW PROPOSED FINISH GRADE WHICHEVER IS APPLICABLE, DIRECTLY IN VERTICAL LINE ABOVE THE FIBER OPTIC CABLE OR DUCT OR ANY OTHER INSTALLATION BEING PLACED AT THE MINIMUM DEPTH OR FORTY-TWO (42") INCHES.
15. BRUSHING AND TRIMMING SHALL BE DONE AS REQUIRED. BRUSH, BRANCHES, AND REFUSE FROM CLEARING OPERATIONS SHALL BE IMMEDIATELY REMOVED FROM THE VICINITY OF THE RIGHT OF WAY.
16. IOWA STATE LAW REQUIRES EXCAVATORS TO NOTIFY IOWA ONE-CALL AT LEAST FORTY-EIGHT (48 HRS) HOURS PRIOR TO ALL EXCAVATIONS (EXCLUDING SATURDAYS, SUNDAYS, AND LEGAL HOLIDAYS). CONTRACTOR SHALL CAREFULLY HAND DIG WITHIN THE TWENTY-FOUR (24") INCH SAFETY ZONE WHEN EXPOSING UNDERGROUND UTILITIES. IOWA ONE-CALL DOES NOT MARK ALL PRIVATE UTILITIES.
17. CONTACTS FOR THIS PROJECT:
 PERMIT AUTHORITIES AND UTILITIES:
 IOWA ONE-CALL(1-800-292-8989) (811 LOCAL ACCESS)
 IOWA DEPARTMENT OF TRANSPORTATION (I.D.O.T.)
 CONSTRUCTION COORDINATOR
 (NA - NAME, PHONE#)
 CITY OF CEDAR FALLS (1-319-272-8600)
 (MATTHEW TOLAN (319)368-5164 OR DAVID WICKE (319)268-5162)
 CEDAR FALLS UTIL., ELECTRIC(C.F.U.)(1-319-266-1761)
 JOHN OSTERHAUS
 CEDAR FALLS UTIL., WATER & GAS(C.F.U.)(1-319-266-1761)
 JERALD LUKENSMEYER

 OTHER:
 WINDSTREAM CONTACTS
 WINDSTREAM CONSTRUCTION COORDINATOR
 (STEPHEN KNESS 1-319-790-7678)
18. BACKFILL COMPACTION FOR ALL AREAS EXCAVATED SHALL BE AS PER THE CURRENT IOWA STATEWIDE URBAN DESIGN AND SPECIFICATIONS (SUDAS) AND THE CURRENT CITY OF CEDAR FALLS, IOWA SUPPLEMENTAL SPECIFICATIONS TO THE (SUDAS) SPECIFICATIONS AS FOLLOWS: USE NO MORE THAN EIGHT(8") INCH THICK LIFTS FOR BACKFILL AREAS MORE THAN THREE (3') FEET BELOW THE BOTTOM OF PAVEMENT. USE NO MORE THAN 6 INCH THICK LIFTS FOR BACKFILL AREAS LESS THAN OR EQUAL TO THREE (3') FEET BELOW THE BOTTOM OF PAVEMENT. COMPACTION TO AT LEAST NINETY-FIVE (95%) PERCENT OF STANDARD PROCTOR DENSITY WITHIN RIGHT-OF-WAY. OBTAIN REQUIRED COMPACTION WITHIN A SOIL MOISTURE RANGE OF OPTIMUM MOISTURE TO FOUR (4%) PERCENT ABOVE OPTIMUM MOISTURE CONTENT. IN AREAS TO REMAIN UNPAVED, TERMINATE BACKFILL MATERIAL EIGHT (8") INCHES BELOW FINISHED GRADE. USE TOPSOIL FOR THE FINAL EIGHT (8") INCHES ABOVE BACKFILL MATERIAL.
19. SENDING AND RECEIVING PIT AREAS SHALL BE RESTORED TO CONDITIONS EXISTING BEFORE CONSTRUCTION. SEED WITH AN APPROVED IOWA STATEWIDE URBAN DESIGN AND SPECIFICATIONS(SUDAS) SEED MIX.
20. PROTECTIVE BARRICADE FENCING SHALL BE IN PLACE AT HAZARDS TO THE PUBLIC WHEN WORKERS ARE NOT PRESENT. TRAFFIC CONTROL AND PROTECTION SHALL BE UTILIZED AT ALL TIMES IN CONFORMANCE WITH IOWA DEPARTMENT OF TRANSPORTATION STANDARDS OR AS MODIFIED PER THE CITY ENGINEER OF THE CITY OF CEDAR FALL, IOWA.
21. AERIAL INSTALLATION OF UTILITY SERVICES WITHIN THE CITY OF CEDAR FALLS, IOWA SHALL NOT BE ALLOWED.

ADDRESS: W 12TH ST & UNION RD, CEDAR FALLS, IA 50613
 BLACK HAWK COUNTY, IA
 PERMIT REQUIRED- CITY
LOCATE ALL FACILITIES PRIOR TO DIGGING
IA - IOWA ONE CALL - 811 - 1-800-292-898

SCALE: NTS



ENGINEER: **WINDSTREAM -**
STEPHEN KNESS
 FIELD ENGINEER: **PEARCE SERVICES**
TROY OZBUN
 DRAWN BY: **PEARCE SERVICES**
RACHITA SHARMA

PROJECT: 707402475

EXCHANGE: CDFLIA
SHEET: 05 OF 10

DATE: 07/15/2021



NOTE(TRANSITION OF OVERLASH TO UNDERGROUND): ON PLAN SETS SUBMITTALS THAT DEPICT BOTH PROPOSED UNDERGROUND AND OVERHEAD INSTALLATIONS WITH ALL STARTING POINTS AND ALL ENDING POINTS FULLY SHOWN AND DESCRIBED, CONDITIONAL APPROVAL OF ALL UNDERGROUND WORK CAN BE GIVEN BY THE CITY ENGINEERING DIVISION AFTER REVIEW ITEMS RELATING TO UNDERGROUND INSTALLATION ONLY, ARE PROPERLY ADDRESSED EXCLUDING TRANSITION OF OVERLASH OR ABOVE GROUND INSTALLATIONS ON POLES IS AT THE DISCRETION OF CEDAR FALLS UTILITIES (CFU). SUBMIT A POLE STUDY TO CFU FOR ADDITIONAL LOADING. CONTACT JOHN OSTERHAUS AT THE CEDAR FALLS UTILITIES (CFU) ELECTRIC DIVISION AT (319)268-5298.

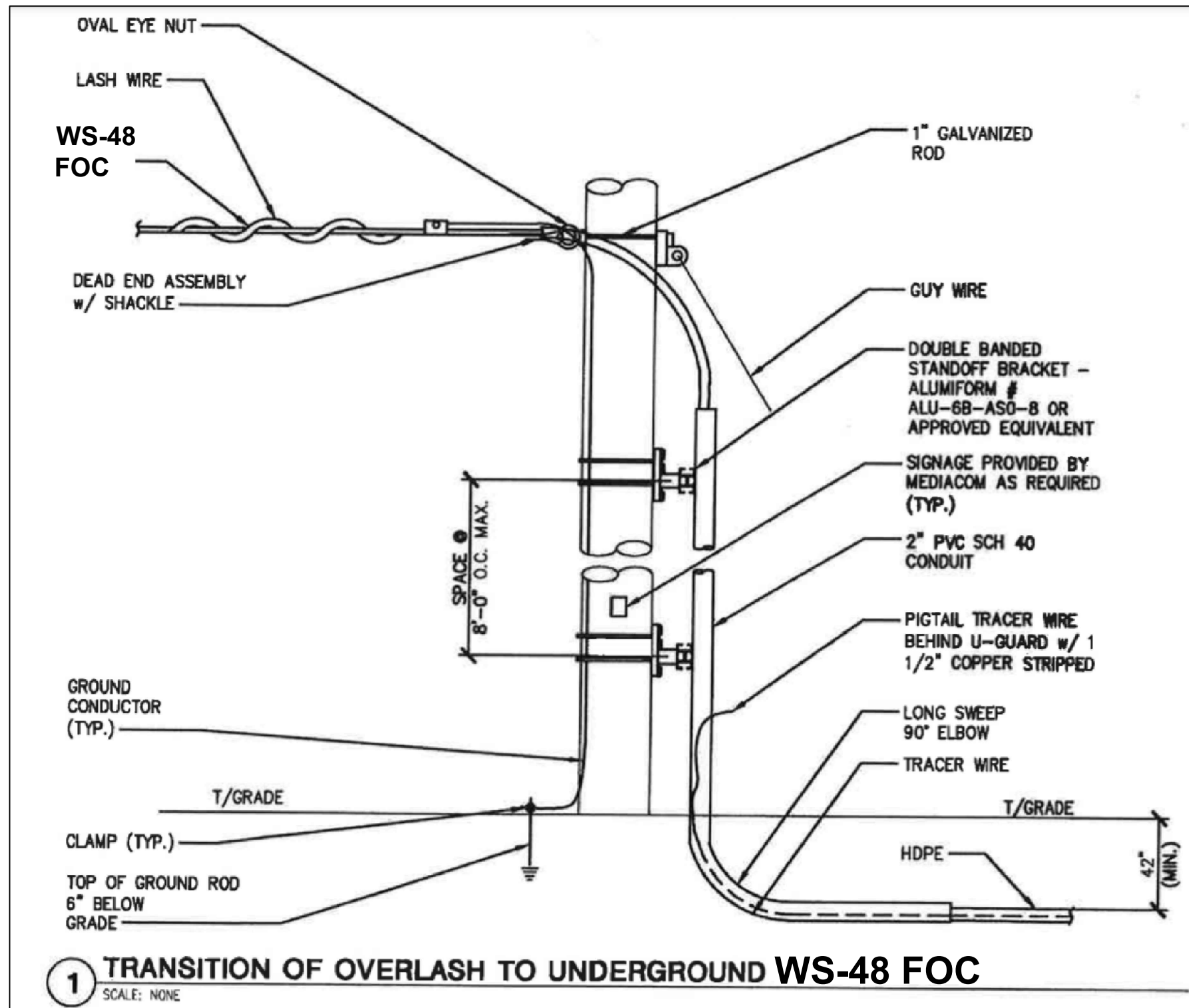

1 TRANSITION OF OVERLASH TO UNDERGROUND WS-48 FOC
SCALE: NONE

ADDRESS: W 12TH ST & UNION RD, CEDAR FALLS, IA 50613
BLACK HAWK COUNTY, IA
PERMIT REQUIRED- CITY
LOCATE ALL FACILITIES PRIOR TO DIGGING
IA - IOWA ONE CALL - 811 - 1-800-292-898

SCALE: 1:50



ENGINEER: **WINDSTREAM** - STEPHEN KNESS
FIELD ENGINEER: **PEARCE SERVICES** TROY OZBUN
DRAWN BY: **PEARCE SERVICES** RACHITA SHARMA

PROJECT: 707402475

EXCHANGE: CDFLIA
SHEET: 06 OF 10

DATE: 07/15/2021



GENERAL NOTES

1. CONTRACTOR PRACTICES AND ALL FINISHED WORK SHALL CONFIRM TO THE CURRENT STATEWIDE URBAN DESIGN AND SPECIFICATIONS (SUDAS) PROGRAM, INCLUDING ALL LOCAL GOVERNMENTAL SUPPLEMENTAL SPECIFICATIONS AND CEDAR FALLS SPECIFICATIONS IN EFFECT WITHIN THE APPLICABLE JURISDICTION. ALL AREAS WHERE WORK IS PERFORMED OR AFFECTED BY THE WORK SHALL BE RETURN TO A CONDITION EQUAL TO BETTER THAN THEIR ORIGINAL CONDITION. THE CEDAR FALLS CITY ENGINEER WILL GIVE FINAL DETERMINATION WHETHER ALL "RETURNED CONDITIONS" ARE EQUAL TO OR BETTER THAN THE ORIGINAL(AND ACCEPTABLE).
2. CONTRACTOR PRACTICES AND ALL FINISHED WORK SHALL CONFORM TO ALL CURRENT STANDARD DRAWINGS PER NOTE NUMBER 1. AND ALL OTHER STANDARD DRAWINGS PER THE CITY OF CEDAR FALLS, IOWA.
3. THE APPROXIMATE LOCATION OF KNOWN CABLES AND UTILITIES ARE INDICATED ON THE PLANS. ALL CABLES AND UTILITIES MAY NOT BE SHOWN. PRIOR TO BEGINNING ANY WORK ALL CONTRACTORS SHALL HAVE CONTACTED ONE CALL TO LOCATE TELEPHONE, GAS, WATER, SEWER, COMMUNICATION, LIGHTING LINES AND OTHER CABLES/UTILITIES WITHIN THE CONSTRUCTION SITE. UNDERGROUND UTILITIES, SHOWN OR NOT, WILL BE LOCATED AND FLAGGED BY THE OWNER OF THE UTILITY UPON THE REQUEST OF THE CONTRACTOR. NO EXCAVATION WILL BE PERMITTED IN THE AREA OF THE UNDERGROUND UTILITIES UNTIL ALL SUCH FACILITIES HAVE BEEN LOCATED AND IDENTIFIED TO SATISFACTION OF ALL PARTIES. THE CONTRACTOR SHALL BE RESPONSIBLE FOR THE PROTECTION OF ALL UNDERGROUND AND AERIAL UTILITIES AND CONSTRUCTION.
4. DIMENSIONS SHOWN ON THE PLAN SHEETS ARE ONLY ESTIMATIONS BY THE PEARCE SERVICES "FIELD ENGINEER", TROY OZBUN, AND PEARCE SERVICES TECHNICIAN, GENNIFER HANKINS AND RACHITA SHARMA. THE CONTRACTOR'S BID SHALL INCLUDE VERIFYING EXACT DIMENSIONS.
5. FOR ALL PUBLIC RIGHT OF WAY, PUBLIC PROPERTIES; ALL CONDUITS AND FIBER OPTIC CABLE SHALL BE PLACED AT A MINIMUM DEPTH OF:
 - A. SIXTY(60") INCHES BELOW A LINE FROM SIX (6") INCHES ABOVE STREET GUTTER TO SIX(6") ABOVE STREET GUTTER ON PUBLIC STREETS AND FOR ALLEYS, BELOW THE CROSS SECTION LOW POINT OF ALLEYS, FOR THE ENTIRE ALLEY WIDTH,
 - B. FORTY EIGHT (48") INCHES BELOW ALL DRIVEWAYS, RECREATIONAL TRAILS, SIDEWALKS, AND LONGITUDINAL RURAL DITCH LINES IN THE PUBLIC RIGHT OF WAY,
 - C. FORTY TWO(42") INCHES IN THE GRASSED, SUBURBAN SECTIONS, PUBLIC RIGHT OF WAY,
 - D. TWELVE (12") BELOW PUBLIC STREET LONGITUDINAL SUBDRAINS,
 - E. TWENTY FOUR(24") INCHES BELOW PUBLIC STORM SEWERS, PUBLIC CULVERTS, AND /OR PUBLIC WATERWAY FLOW LINE(S) BEING CROSSED, AND
 - F. AT A MINIMUM CLEARANCE DISTANCE OF TWO (2') FEET FROM ELECTRICAL UTILITIES AND ONE AND ONE HALF(1½) FEET FROM ALL OTHER UTILITIES.
6. ALL POTHOLES IN SIDEWALK SHALL BE REPLACED WITH FULL PANEL REPLACEMENT CONSTRUCTION.
7. MISCELLANEOUS STRUCTURES AND OBSTRUCTIONS SUCH AS SIGN POSTS, MAIL BOXES, METER BOX, ETC., SHALL BE AVOIDED OR REMOVED AND REINSTALLED TO A CONDITION EQUAL TO OR BETTER THAN THEIR ORIGINAL CONDITION. THE CEDAR FALLS CITY ENGINEER WILL GIVE FINAL DETERMINATION WHETHER ALL RETURNED CONDITIONS ARE EQUAL TO OR BETTER THAN THE ORIGINAL. EXISTING PAVEMENTS, TURF, ROADS, CABLES, UTILITIES, AND INCIDENTALS THAT ARE DAMAGED BY THE CONTRACTOR SHALL BE REPAIRED BY THE CONTRACTOR BY NO COST OF OWNER.
8. EXCAVATIONS THAT WILL BE OCCUPIED BY PERSONNEL SHALL BE MADE IN ACCORDANCE WITH THE OCCUPATIONAL SAFETY HEALTH ADMINISTRATION (OSHA) CONSTRUCTION STANDARD-29 CFR PART 1926, SUBPART P-EXCAVATIONS OSHA STATES THAT A SOIL SHALL BE RECLASSIFICATION CHANGE IN ANY WAY. SHEET PILING AND OR SHORING WILL BE NECESSARY IF THE SIDES OF THE EXCAVATION CANNOT BE SLOPED TO MEET OSHA REGULATIONS.
9. WHEN ANY CONFLICT(S) ARE IDENTIFIED DURING CONSTRUCTION WORK, THE CONTRACTOR SHALL ADVISE THE CEDAR FALLS CITY ENGINEER AND THE WINDSTREAM ENGINEER, STEPHEN KNESS
10. CONSTRUCTION VEHICLES MUST HAVE COMPANY NAME AND CONTACT INFORMATION DISPLAYED.
11. THE CONTRACTOR SHALL PROVIDE NOTIFICATION TO PROPERTY OWNERS PRIOR TO BEGINNING WORK.
12. RIGHT OF WAY RESTORATION AND STREET/SIDEWALK REPAIR/REPLACEMENT SHALL BE IN COMPLIANCE WITH THE LOCAL PERMITTING AUTHORITY. ANY SIDEWALK REMOVED SHALL BECOME A PRIORITY TO BE REPLACED PER ALL THE CITY OF CEDAR FALLS SIDEWALK PERMIT REQUIREMENTS AND GUIDELINES.

TRAFFIC CONTROL PLAN (TCP) NOTES

1. TRAFFIC CONTROL CONFORMING TO CURRENT IOWA DEPARTMENT OF TRANSPORTATION(I.D.O.T.) AND THE CURRENT MANUAL OF UNIFORM TRAFFIC CONTROL DEVICES(M.U.T.C.D.) SHALL BE CONTRACTOR'S RESPONSIBILITY.
2. TRAFFIC CONTROL CONFORMING TO CURRENT IOWA DEPARTMENT OF TRANSPORTATION(I.D.O.T.) AND THE CURRENT MANUAL OF UNIFORM TRAFFIC CONTROL DEVICES(M.U.T.C.D.) SHALL BE CONTRACTOR'S RESPONSIBILITY.
3. THE FOLLOWING SPECIAL PROVISIONS SHALL APPLY TO TRAFFIC REGULATIONS DURING THE ENTIRE EXTENT OF THE PROJECT WORK:
 - A. THERE SHALL BE AT ALL TIMES ADEQUATE VEHICLE AND PEDESTRIAN ACCESS FOR INGRESS AND EGRESS FOR THE PROPERTIES ADJACENT TO THE PROJECT WORK.
 - B. DURING NON-WORKING HOURS, THE CONTRACTOR SHALL KEEP THE EXISTING TRAFFIC LANES CLEAR FROM INTERFERENCE, INCLUDING ALL APPROACHES AND INTERSECTIONS.
 - C. IF LANE BLOCKAGE IS UNAVOIDABLE, THE CONTRACTOR SHALL NOTIFY THE CITY TRAFFIC ENGINEERING DEPARTMENT, POLICE DEPARTMENT, FIRE DEPARTMENT, AMBULANCE SERVICES, SCHOOL BUS GARAGES, AND ALL OTHER AGENCIES OPERATIONS AS APPROPRIATE SO THAT THESE AGENCIES MAY PLAN TO RE ROUTE THEIR VEHICLES AROUND THE CONSTRUCTION WORK ZONE(S).
4. THE CONTRACTOR, TH CONSTRUCTION, WINDSTREAM'S INSTALLATION CONTRACTOR SHALL ASSUME THE ROLE OF TRAFFIC CONTROL SUPERVISOR(TCS).
5. IF THE UTILITY WORK INSTALLATION DEVIATES FROM THE PLAN SET DESIGN, THE TRAFFIC CONTROL SUPERVISOR SHALL BE RESPONSIBLE FOR VERIFYING WITH THE CITY OF CEDAR FALLS ENGINEERING DIVISION AND THE WINDSTREAM ENGINEER, STEPHEN KNESS, THAT TRAFFIC CONTROL PLAN CHANGES ARE NOT REQUIRED FOR MAXIMUM SAFETY FOR WORKERS AND THE PUBLIC.
6. WHERE HAZARDOUS CONDITIONS EXIST, PROPER SIGNING, FLAGGING, AND BARRICADING SHALL BE PROVIDED AS DIRECTED BY THE WINDSTREAM ENGINEER OR THE CEDAR FALLS CITY ENGINEER. SUPPLEMENTAL SIGNS, FLAG PERSON(S) AND BARRICADES SHALL BE PROVIDED BY THE CONTRACTOR. NO TRENCH OR EXCAVATION SIDE SHALL BE LEFT UNATTENDED, AT ANY TIME, OR OPEN OVERNIGHT. ALL EXCAVATION SHALL BE FENCED AND COVERED WHEN THE INSTALLATION CONTRACTOR IS NOT PRESENT.

FOR ALL PUBLIC RIGHT OF WAY AND PUBLIC PROPERTIES; ALL CONDUITS AND FIBER OPTIC CABLE SHALL BE PLACED AT A MINIMUM DEPTH OF:

- A) SIXTY (60") INCHES BELOW A LINE FROM SIX(6") INCHES ABOVE STREET GUTTER TO SIX(6") INCHES ABOVE STREET GUTTER ON PUBLIC STREETS AND FOR ALLEYS, BELOW THE CROSS SECTION LOW POINT OF ALLEYS, FOR THE ENTIRE ALLEY WIDTH,
- B) FORTY-EIGHT (48") INCHES BELOW ALL DRIVEWAYS, RECREATIONAL TRAILS, SIDEWALKS, AND LONGITUDINAL RURAL DITCH LINES IN THE PUBLIC RIGHT OF WAY,
- C) FORTY-TWO (42") IN THE GRASSED, SUBURBAN SECTION, PUBLIC RIGHT OF WAY,
- D) TWELVE (12") INCHES BELOW PUBLIC STREET LONGITUDINAL SUBDRAINS,
- E) TWENTY FOUR (24") INCHES BELOW PUBLIC STORM SEWERS, PUBLIC CULVERTS, AND/OR PUBLIC WATERWAY FLOW LINE(S) BEING CROSSED, AND
- F) AT A MINIMUM CLEARANCE DISTANCE OF TWO (2') FEET FROM ELECTRICAL UTILITIES AND ONE AND ONE HALF (1 ½) FEET FROM ALL OTHER UTILITIES.
(ALL DIMENSIONS APPLY, UNLESS OTHERWISE SPECIFIED ON AN INDIVIDUAL PLAN VIEW, INDIVIDUAL PLAN AND PROFILE VIEW OR INDIVIDUAL PROFILE VIEW SHEET OF THE PLAN SET.)

ADDRESS: W 12TH ST & UNION RD, CEDAR FALLS, IA 50613
 BLACK HAWK COUNTY, IA
 PERMIT REQUIRED- CITY
LOCATE ALL FACILITIES PRIOR TO DIGGING
IA - IOWA ONE CALL - 811 - 1-800-292-898

SCALE: NTS



ENGINEER: **WINDSTREAM - STEPHEN KNESS**
 FIELD ENGINEER: **PEARCE SERVICES TROY OZBUN**
 DRAWN BY: **PEARCE SERVICES RACHITA SHARMA**

PROJECT: 707402475

EXCHANGE: CDFLIA
SHEET: 07 OF 10

DATE: 07/15/2021



TYPICAL STORM SEWER CROSSING

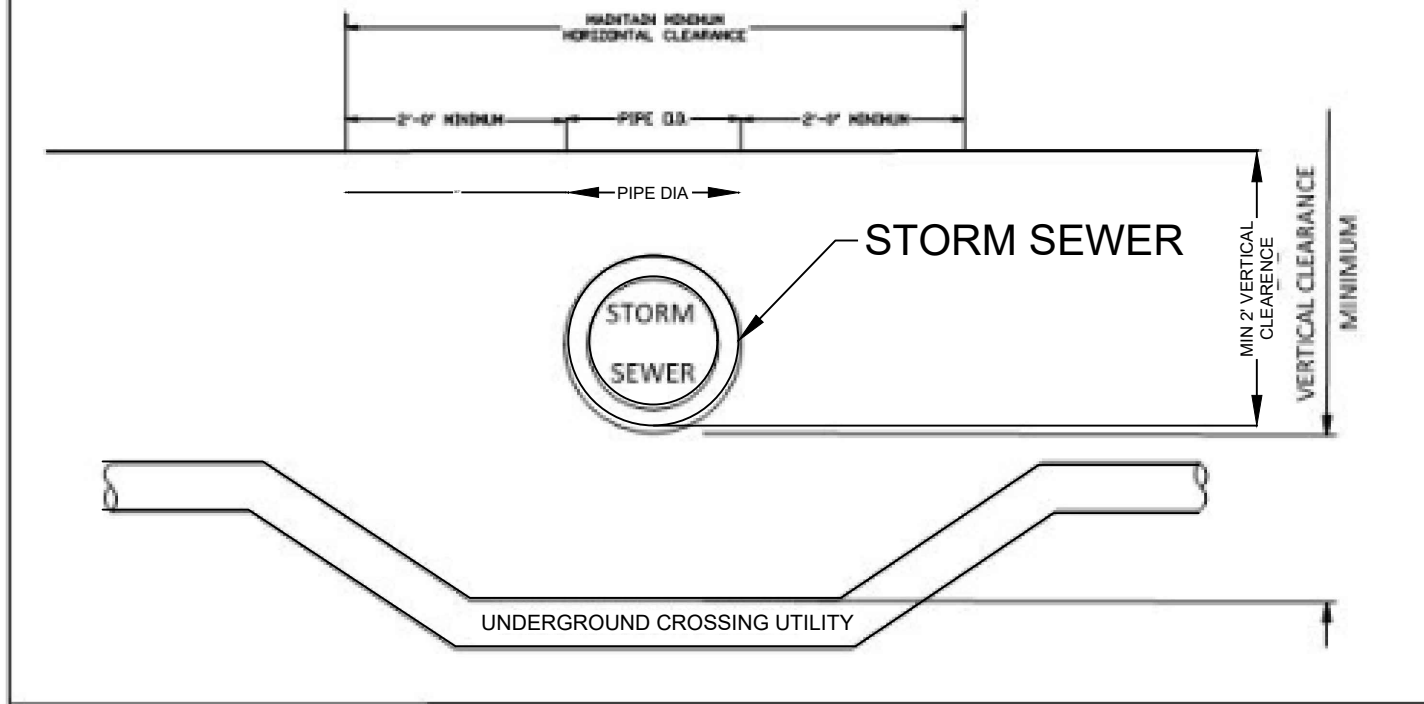

FUTURE PATH DETAIL

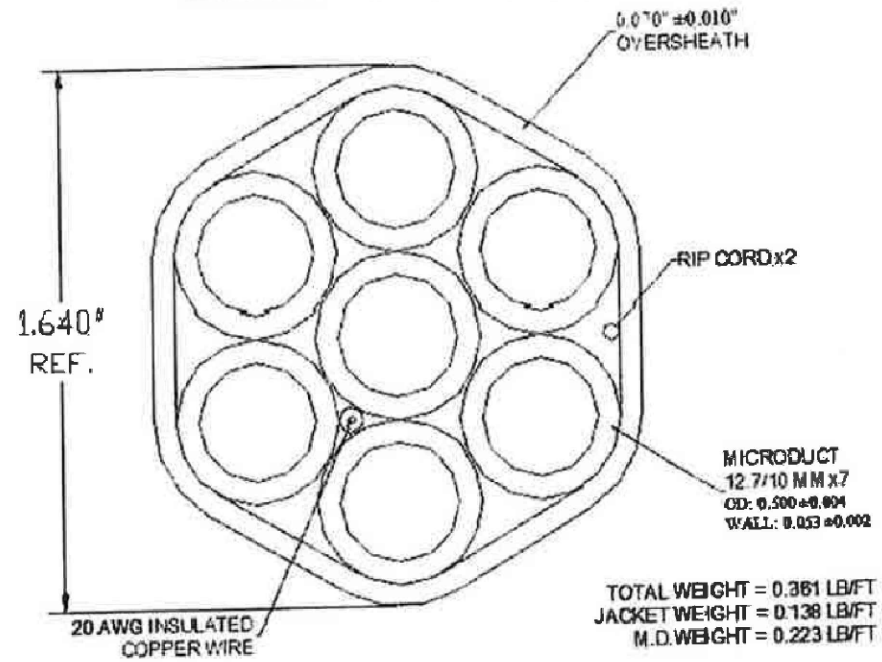

TYPICAL DETAIL "A"

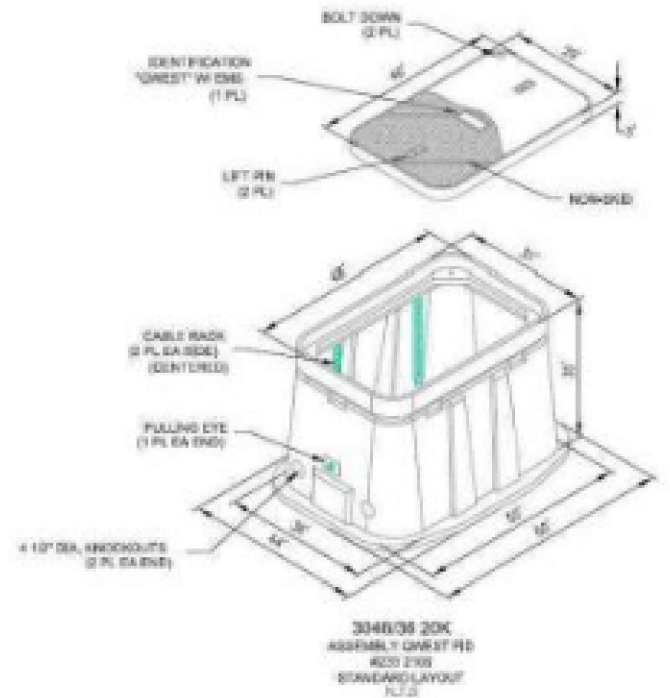

STANDARD BORE DETAILS OF THE TELCO PLACEMENT

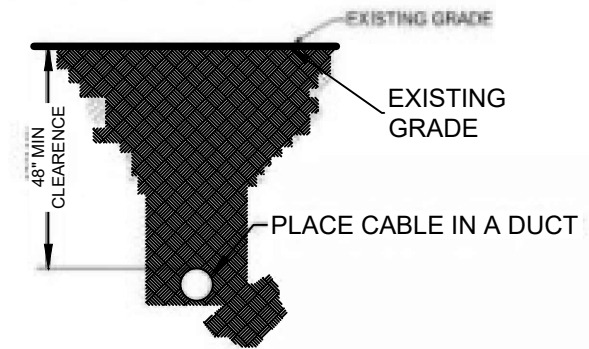

STANDARD TRENCH DETAILS OF THE TELCO PLACEMENT

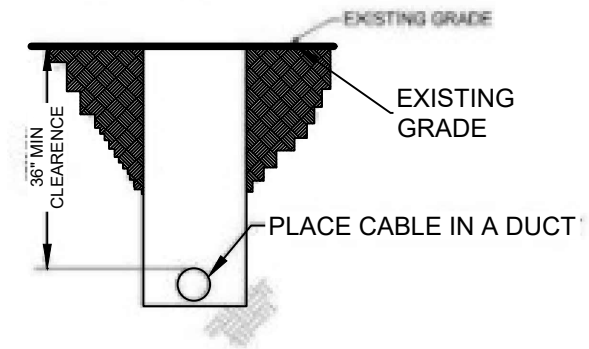

ADDRESS: W 12TH ST & UNION RD, CEDAR FALLS, IA 50613
 BLACK HAWK COUNTY, IA
 PERMIT REQUIRED- CITY
LOCATE ALL FACILITIES PRIOR TO DIGGING
 IA - IOWA ONE CALL - 811 - 1-800-292-898

SCALE: NTS



ENGINEER: WINDSTREAM - STEPHEN KNESS
 FIELD ENGINEER: PEARCE SERVICES TROY OZBUN
 DRAWN BY: PEARCE SERVICES RACHITA SHARMA

PROJECT: 707402475

EXCHANGE: CDFLIA
 SHEET: 08 OF 10

DATE: 07/15/2021



RECREATIONAL PLANS

LEGEND

Features	Existing	Proposed
Spot Elevation	93.0	93.0
Contour Elevation	93	93
Fence (Barbed, Field, Hog)	-x-x-	-x-x-
Fence (Chain Link)	-//-	-//-
Fence (Wood)	-	-
Fence (Silt)	-	-
Tree Line	-~	-~
Tree Stump	-x	-x
Deciduous Tree \ Shrub	(circle with leaf)	(circle with leaf)
Coniferous Tree \ Shrub	(circle with needle)	(circle with needle)
Communication	C(x)	C
Overhead Communication	OC(x)	OC
Fiber Optic	FO(x)	FO
Underground Electric	E(x)	E
Overhead Electric	OE(x)	OE
Gas Main with Size	4" G(x)	4" G
High Pressure Gas Main with Size	4" HPG(x)	4" HPG
Water Main with Size	8" W(x)	8" W
Sanitary Sewer with Size	8" S(x)	8" S
Duct Bank	DUCT(x)	DUCT
Test Hole Location for SUE w/D	⊗1	

(* Denotes the survey quality service level for utilities

P.I. Sta. 62+64.67
 $\Delta = 37^\circ 15' 44.68''$ (LT)
 T = 20.23'
 L = 39.02'
 E = 3.32'
 R = 60.00'

P.I. Sta. 63+03.66
 $\Delta = 37^\circ 12' 54.04''$ (RT)
 T = 20.20'
 L = 38.97'
 E = 3.31'
 R = 60.00'

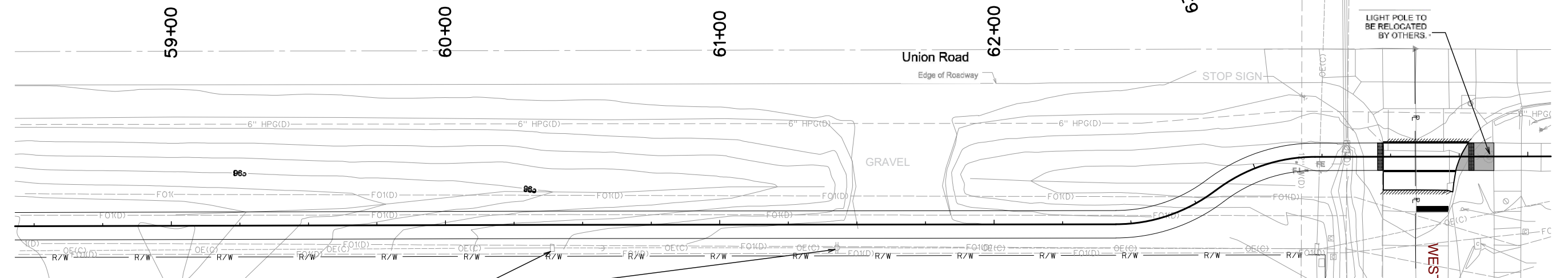

CONTRACTOR SHALL MAINTAIN A MINIMUM 2' HORIZONTAL CLEARANCE BETWEEN POLES AND EDGE OF TRAIL.

12
TERRACES AT WEST GLEN, LLC
 7511 UNIVERSITY AVE

LEGEND

- PCC TRAIL IMPROVEMENTS
- PCC PAVEMENT
- PCC DRIVEWAY
- GRADING LIMITS

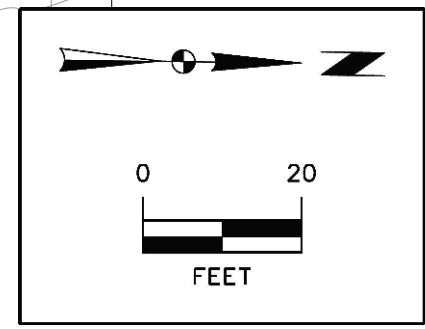

Sanitary Manhole	⊗
Storm Sewer with Size	12" ST
Storm Manhole	⊗
Single Storm Sewer Intake	⊗
Double Storm Sewer Intake	⊗
Fire Hydrant	⊗
Fire Hydrant on Building	⊗
Water Main Valve	⊗
Water Service Valve	⊗
Well	⊗
Utility Pole	⊗
Guy Anchor	⊗
Utility Pole with Light	⊗
Utility Pole with Transformer	⊗
Street Light	⊗
Yard Light	⊗
Electric Box	⊗
Electric Transformer	⊗
Traffic Sign	⊗
Communication Pedestal	⊗
Communication Manhole	⊗
Communication Handhole	⊗
Fiber Optic Manhole	⊗
Fiber Optic Handhole	⊗
Gas Valve	⊗
Gas Manhole	⊗
Gas Apparatus	⊗
Fence Post or Guard Post	⊗
Underground Storage Tank	⊗
Above Ground Storage Tank	⊗
Sign	⊗
Satellite Dish	⊗
Mailbox	⊗
Soil Boring	⊗

ADDRESS: W 12TH ST & UNION RD, CEDAR FALLS, IA 50613
 BLACK HAWK COUNTY, IA
 PERMIT REQUIRED- CITY
LOCATE ALL FACILITIES PRIOR TO DIGGING
IA - IOWA ONE CALL - 811 - 1-800-292-898

SCALE: NTS



ENGINEER: **WINDSTREAM - STEPHEN KNESS**
 FIELD ENGINEER: **PEARCE SERVICES TROY OZBUN**
 DRAWN BY: **PEARCE SERVICES RACHITA SHARMA**

PROJECT: 707402475
 EXCHANGE: CDFLIA
 SHEET: 09 OF 10
 DATE: 07/15/2021



Figure 6H-3. Work on the Shoulders (TA-3)

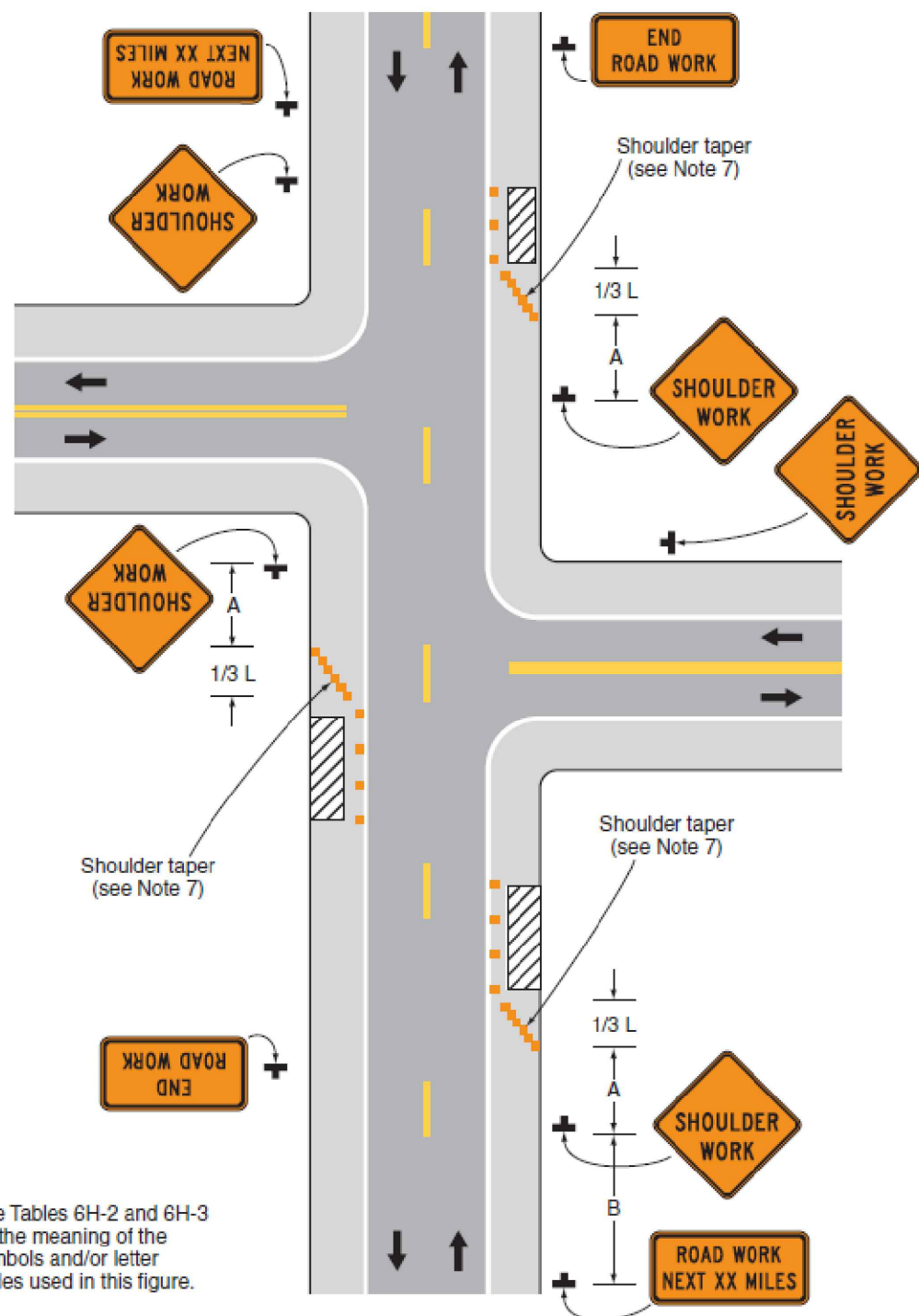

Note: See Tables 6H-2 and 6H-3 for the meaning of the symbols and/or letter codes used in this figure.

Typical Application 3

Notes for Figure 6H-3—Typical Application 3
Work on the Shoulders

Guidance:

1. A SHOULDER WORK sign should be placed on the left side of the roadway for a divided or one-way street only if the left shoulder is affected.

Option:

2. The Workers symbol signs may be used instead of SHOULDER WORK signs.
3. The SHOULDER WORK AHEAD sign on an intersecting roadway may be omitted where drivers emerging from that roadway will encounter another advance warning sign prior to this activity area.
4. For short duration operations of 60 minutes or less, all signs and channelizing devices may be eliminated

if a vehicle with activated high-intensity rotating, flashing, oscillating, or strobe lights is used.

5. Vehicle hazard warning signals may be used to supplement high-intensity rotating, flashing, oscillating, or strobe lights.

Standard:

6. Vehicle hazard warning signals shall not be used instead of the vehicle's high-intensity rotating, flashing, oscillating, or strobe lights.

7. When paved shoulders having a width of 8 feet or more are closed, at least one advance warning sign shall be used. In addition, channelizing devices shall be used to close the shoulder in advance to delineate the beginning of the work space and direct vehicular traffic to remain within the traveled way.

ADDRESS: W 12TH ST & UNION RD, CEDAR FALLS, IA 50613
BLACK HAWK COUNTY, IA
PERMIT REQUIRED- CITY
LOCATE ALL FACILITIES PRIOR TO DIGGING
IA - IOWA ONE CALL - 811 - 1-800-292-898

SCALE: NTS



ENGINEER: WINDSTREAM - STEPHEN KNESS
FIELD ENGINEER: PEARCE SERVICES TROY OZBUN
DRAWN BY: PEARCE SERVICES RACHITA SHARMA

PROJECT: 707402475

EXCHANGE: CDFLIA
SHEET: 10 OF 10

DATE: 07/15/2021





DEPARTMENT OF PUBLIC WORKS

City of Cedar Falls
 220 Clay Street
 Cedar Falls, Iowa 50613
 Phone: 319-268-5161
 Fax: 319-268-5197
 www.cedarfalls.com

MEMORANDUM
Engineering Division

TO: Honorable Mayor Robert M. Green and City Council

FROM: Matthew Tolan, EI, Civil Engineer II

DATE: January 17, 2023

SUBJECT: Oak Park Sanitary Sewer Repair Project
 City Project Number: SA-002-3182
 Temporary Easement

The City of Cedar Falls has completed the final design of the Oak Park Sanitary Sewer Repair Project. With the installation of a new sanitary sewer pump station, one (1) additional acquisition was necessary for the right-of-way needs. The project will require the acquisition of one (1) additional temporary from a total of 9 properties to complete the repairs.

The owner of the following property has accepted our offer:

Parcel #	Owner	Address/Parcel ID	Acquisition Type
122	Tahseen & Shameem Husain	2915 Minnetonka Drive	Temporary

The City will use Sewer Rental Funds for the design and right of way portion of this project.

Staff recommends that the City Council state their support in the form of a resolution approving the acquisitions and authorize the Mayor to execute the agreements for the Oak Park Sanitary Sewer Repair project.

If you have any questions or need additional information, please feel free to contact me.
 xc: Chase Schrage, Director of Public Works
 David Wicke, City Engineer

CITY OF CEDAR FALLS
OWNER PURCHASE AGREEMENT

Property Address: 2915 Minnetonka Drive, Cedar Falls County Tax Parcel No: 891402302003
Parcel Number: 122 Project Name: Oak Park Blvd Sewer Replacement
Project Number: SA-002-3182

THIS OWNER PURCHASE AGREEMENT is entered into on this ____ day of _____, 2022, by and between Tahseen Husain AND Shameem Husain, (“Seller”), and the City of Cedar Falls, Iowa, (“Buyer”).

- 1. Buyer hereby agrees to acquire, and Seller hereby agrees to convey, a Temporary Construction Easement.

See Temporary Construction Easement Diagram attached (Exhibit A). (The “Premises”)

Acquisition of the Temporary Construction Easement is for the purposes set forth in the Temporary Construction Easement Agreement attached (Exhibit B). The Temporary Construction Easement shall expire upon completion of the Project and acceptance of the Project by the City Council of the City of Cedar Falls unless the Temporary Construction Easement Agreement provides otherwise, in which case the terms of the Temporary Construction Easement Agreement shall control. This acquisition is for public purposes through an exercise of the power of eminent domain.

- 2. In consideration of Seller’s conveyance of a temporary easement interest in the Premises to Buyer, Buyer agrees to pay to Seller the following:

BREAKDOWN: ac. = acres		sq. ft. = square feet		
Land by Fee Title	_____	sq. ft.		\$ _____
Underlying Fee Title	_____	sq. ft.		\$ _____
Temporary Easement	2000	sq. ft.		\$ 800.00
Permanent Easement	_____	sq. ft.		\$ _____
Buildings				\$ _____
Additional Damages:				\$ _____
Total				\$ 800.00

Payment shall be due on the closing date unless otherwise specified as follows: Payment to be certified mailed to Seller the week after approval by regular City Council meeting.

- 3. Seller agrees to execute a Temporary Construction Easement Agreement in the form attached hereto as Exhibit B.
- 4. Seller consents to any change of grade of the adjacent roadway and accepts payment under this Agreement for any and all damages arising therefrom. Seller acknowledges full settlement and payment from Buyer for all claims according to the terms of this Agreement and discharges Buyer from any and all liability arising out of this Agreement and the construction of the public improvement project, except as set forth in Paragraph 8 below.
- 5. Possession of the Premises is the essence of this Agreement and Buyer may enter and assume full use and enjoyment of the Seller’s interest in the Premises according to the terms of this Agreement, immediately upon approval of this Agreement by the City Council of the City of Cedar Falls, and payment of the agreed upon price. Notwithstanding the above, Seller grants to Buyer the immediate right to enter the Premises for the purpose of gathering survey and soil data.
- 6. This Agreement shall apply to and bind the assigns, representatives and successors of the Seller.
- 7. This Agreement and all attachments hereto constitute the entire agreement between the Buyer and the

Seller related to the subject matter herein and there is no agreement to do or not to do any act or deed except as specifically provided for herein.

- 8. The Buyer hereby gives notice of Seller's five-year right to renegotiate construction or maintenance damages not apparent at the time of the signing of this Agreement as required by Section 6B.52 of the Code of Iowa.

SELLER'S SIGNATURE AND CLAIMANT'S CERTIFICATION: Upon due approval and execution by the Buyer, we the undersigned claimants certify the total lump sum payment shown herein is just and unpaid.

SELLER:

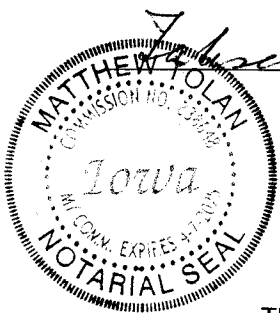

Tehseen Husain 12-29-22
Date

Shameem Husain 12-29-22
Date

State of Iowa

County of Black Hawk

This record was acknowledged before me on the 29th day of December, 2022, by

Tehseen & Shameem Husain as property owners of 2915 Minnesota Drive, Cedar Falls, IA 50613

Matthew Tolman
Signature of notarial officer

4-7-2025
Commission Expires

CITY OF CEDAR FALLS, IOWA (BUYER)

By: _____
Robert M Green, Mayor

ATTEST:

By: _____
Jacqueline Danielsen, MMC
City Clerk

STATE OF IOWA, COUNTY OF BLACK HAWK, ss:

This instrument was acknowledged before me on the _____ day of _____, 20__, by Robert M. Green, Mayor, and Jacqueline Danielsen, MMC, City Clerk, of the City of Cedar Falls, Iowa.

Notary Public in and for the State of Iowa

My Commission Expires:

TEMPORARY CONSTRUCTION EASEMENT AGREEMENT

This Temporary Construction Easement Agreement ("Agreement") is made this _____ day of _____, 20___, by Shameem Husain AND Tahseen Husain ("Grantor"), and City of Cedar Falls, a municipality organized under the laws of the State of Iowa ("Grantee"). In consideration of the sum of one dollar (\$1.00), and other valuable consideration, the receipt of which is hereby acknowledged, Grantor hereby sells, grants and conveys unto Grantee a temporary easement under, through, and across the following described real estate which is owned by Grantor:

See Exhibit A attached (the "Easement Area").

1. Purpose. This temporary construction easement is granted for the purpose of entering, using, occupying, sloping, grading, clearing, grubbing, excavating and storing of materials and equipment during the construction of a public improvement project near the Easement Area, as well as the right of ingress and egress along and over the Easement Area and for any reasonable purpose deemed by the Grantee to be necessary for said public improvement project.

2. Restoration of Easement Area. Grantee agrees to restore at Grantee's cost the Easement Area in a timely manner after completion of the public improvement project, including any construction, reconstruction, maintenance, repair or replacement work. Such restoration shall include, but not be limited to, the restoration of lawns by seeding, complete restoration of any driveways, fences or other structures modified as a requirement of the construction, as well as the repair of any of Grantor's property damaged as set forth in Paragraph 6 below.

3. No Obstructions. Grantor does hereby agree not to create or permit any building to be constructed within the Easement Area, or to cause or permit any other obstruction or condition of any kind or character within the Easement Area upon Grantor's premises that will interfere with the Grantee's exercise and enjoyment of the easement rights hereinabove conveyed.

4. Grantee's Use. The Grantee, its successors and assigns, shall have the right to use and enjoy the Easement Area for the purposes identified hereinabove, it being specifically understood and agreed, however, that in no event shall the Grantee have

any right to erect buildings or similar structures on or over any portion of the Easement Area. If the Grantee should abandon said easement or fail to use the same for a continuous period of two (2) years after removal of its facilities, then said easement, along with any and all rights and interests granted to the Grantee under this Agreement, shall cease and terminate, and all the rights and interests hereby granted shall be vested in the then owner of the fee simple title in and to the land over which said easement crosses. Furthermore, unless resulting from the exercise of the rights granted herein, the Grantee shall not, without Grantor's prior written approval, diminish access, ingress or egress to any portion of the Grantor's Property.

5. Grantor's Use. The Grantee shall exercise reasonable diligence in performing any of its rights within the Easement Area so as (i) to avoid damaging the Easement Area (or any other portion of the Grantor's Property), and (ii) not to unreasonably interfere with the use of the Easement Area (or any other portion of the Grantor's Property) (including, but not limited to, ingress/egress/access), by Grantor, its employees, agents, representatives, customers, or invitees. Grantee shall use reasonable efforts to coordinate with Grantor prior to any construction and/or maintenance and/or any other work within the Easement Area and shall furthermore provide Grantor reasonable prior notice with regard to any such construction and/or maintenance. No excavated dirt or debris may be left within the Easement Area following completion of construction, reconstruction, maintenance, repair or replacement work. All excavated materials shall be properly disposed of by the Grantee following completion of the public improvement project.

6. Liability for Damage. Grantee shall be liable to Grantor for any damage to real or personal property, and for injury to or death of any persons, proximately caused by the acts or omissions of Grantee, or its employees, agents, contractors or subcontractors, which arise out of any work done on or to the Easement Area while Grantee, or its employees, agents, contractors or subcontractors, are exercising any rights with respect to the Easement Area which are granted to Grantee under this Agreement. The provisions of this paragraph shall terminate upon completion of the public improvement project and final acceptance of public improvements by the City Council of Grantee.

7. Expiration of Temporary Easement. This Agreement and the easements in favor of Grantee shall expire upon the earlier of (a) thirty-six (36) months following the execution of this Agreement; or (b) the date on which Grantee completes the public improvement project and final acceptance of public improvements by the city council of the City.

8. Successors and Assigns. This Agreement shall inure to the benefit of and be binding upon the parties' respective successors and assigns.

GRANTOR:

By:

Name: Tahseen Husain

Shameem Husain

Title: Property owner

Property owner

State of Iowa)

County of Black Hawk)

This record was acknowledged before me on the 29th day of December, 2022, by Tahseen & Shameem Husain, as property owners of 2415 Minnetonka Drive, Cedar Falls, IA 50613.



Matthew Tolani

Signature of notarial officer

Stamp

[Public Notary]
Title of Office

[My commission expires: 4-7-2025]

ACCEPTANCE OF TEMPORARY CONSTRUCTION EASEMENT AGREEMENT

The City of Cedar Falls, Iowa ("Grantee"), does hereby accept and approve the foregoing Temporary Construction Easement Agreement.

Dated this ____ day of _____, 20__.

GRANTEE:

CITY OF CEDAR FALLS, IOWA

Robert M. Green, Mayor

ATTEST

Jacqueline Danielsen, MMC
City Clerk

State of _____)

County of _____)

This instrument was acknowledged before me on _____,
20__, by Robert M. Green, Mayor, and Jacqueline Danielsen, MMC, City Clerk, of the
City of Cedar Falls, Iowa.

Notary Public in and for the State of Iowa

My Commission Expires:

INDEX LEGEND

SURVEYOR'S NAME / RETURN TO:
SNYDER & ASSOCIATES, INC.
5005 BOWLING ST. SW SUITE A
CEDAR RAPIDS, IOWA 52404
319-362-9394
twforinash@snyder-associates.com
SERVICE PROVIDED BY:
SNYDER & ASSOCIATES, INC.
SURVEY LOCATED:
LOT 122
ROYAL OAKS ESTATES
REQUESTED BY:
CITY OF CEDAR FALLS

TEMPORARY CONSTRUCTION EASEMENT EXHIBIT

EASEMENT DESCRIPTION

THE EASTERLY 20 FEET OF THE THE NORTHEASTERLY 100 FEET OF LOT 122, ROYAL OAKS ESTATES TO THE CITY OF CEDAR FALLS, BLACK HAWK COUNTY, IOWA, CONTAINING 0.05 ACRES (2,000 S.F.) MORE OR LESS.

PROPERTYT SUBJECT TO ANY AND ALL EASEMENTS OF RECORD.

LEGEND

Survey

Section Corner
1/2" Rebar
(Unless Otherwise Noted)

ROW Rail
Calculated Point

Found



Set



DATE OF SURVEY

06-03-2019

OWNER

HUSAIN, TAHSEEN
HUSAIN, SHAMEEM

TEMPORARY CONSTRUCTION EASEMENT EXHIBIT

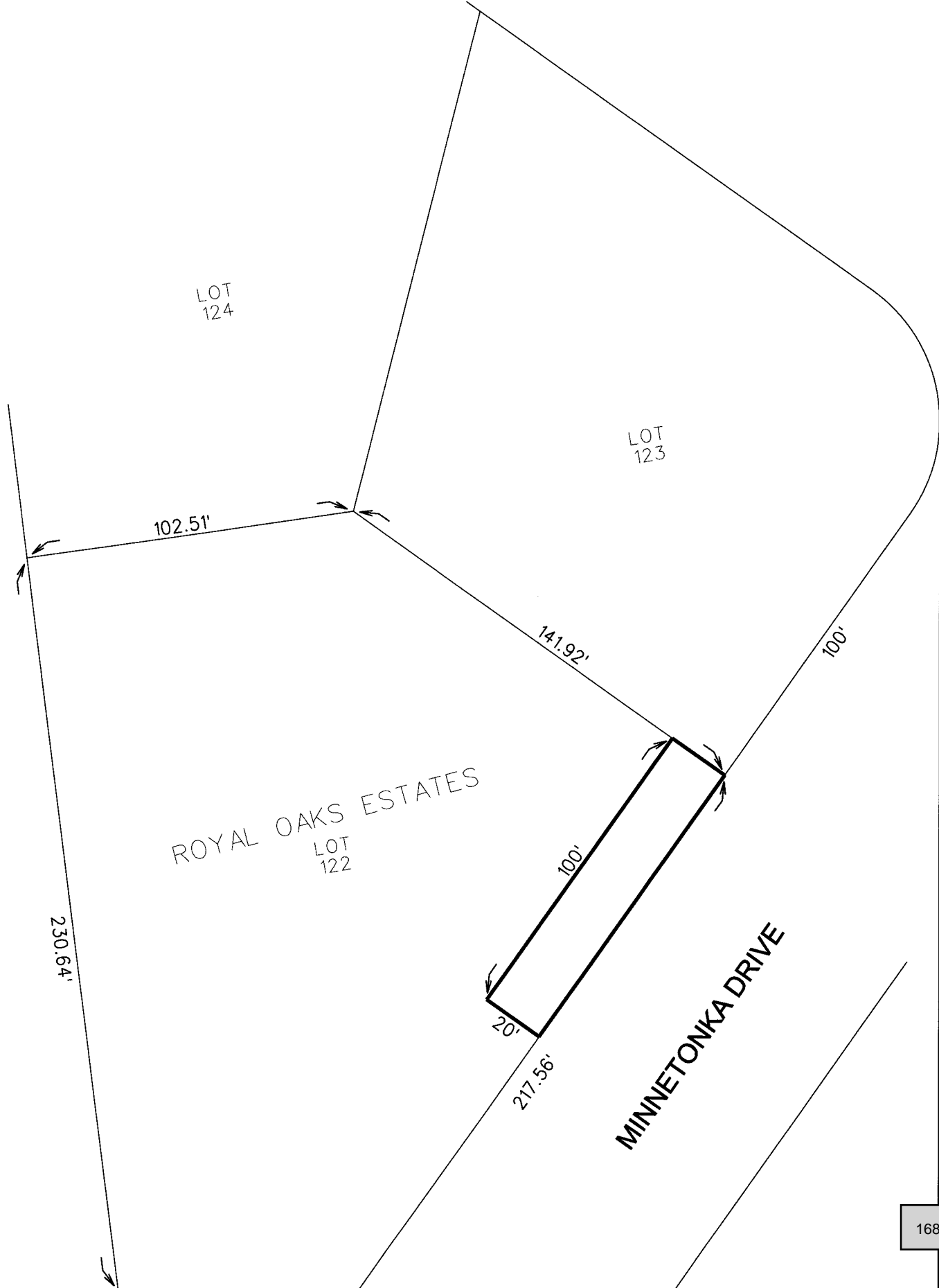

DEPARTMENT OF PUBLIC WORKS

City of Cedar Falls
 220 Clay Street
 Cedar Falls, Iowa 50613
 Phone: 319-268-5161
 Fax: 319-268-5197
www.cedarfalls.com

MEMORANDUM
Engineering Division

TO: Honorable Mayor Robert M. Green and City Council

FROM: Matthew Tolan, EI, Civil Engineer II

DATE: January 17, 2022

SUBJECT: Wild Horse Ridge Fifth Addition
 Final Acceptance of Improvements
 Project No. SU – 454 – 3258

Construction work has been completed on the public improvements in the Wild Horse Ridge Fifth Addition. The project was designed by Clapsaddle-Garber Associates, Inc. and has been completed in accordance with the project plans and the City of Cedar Falls Standard Specifications. The project was inspected by the City of Cedar Falls Engineering Division.

The Engineering Division has reviewed and approved the project plans and specifications, inspected the project through the construction process; and has received and reviewed the project reports and certifications. The project documentation is in order and the project is complete and ready for City Council acceptance. Attached are copies of the Maintenance Bonds from the developer, Midwest Development, and the Final Plat for the Wild Horse Ridge Fifth Addition.

The Wild Horse Ridge Fifth Addition has been constructed in reasonable compliance with the project plans and specifications. The Engineering Division recommends that the City Council approve and accept the public improvements for the Wild Horse Ridge Fifth Addition.

Matthew Tolan, EI, Civil Engineer II

January 9, 2023

Date

xc: Chase Schrage, Director of Public Works
 David Wicke, P.E., City Engineer

FINAL PLAT

WILD HORSE RIDGE FIFTH ADDITION

CEDAR FALLS, BLACK HAWK COUNTY, IOWA

JANUARY 2022

SURVEYOR AND ENGINEER

TRAVIS R STEWART, P.L.S.
 ADAM DATERS, P.E.
 CLAPSADDLE-GARBER ASSOCIATES
 5106 NORDIC DRIVE
 CEDAR FALLS, IOWA 50613
 PHONE 319-266-0258

ZONING INFORMATION:

RP (UNLESS NOTED OTHERWISE)

TYPICAL BUILDING SETBACKS

FRONT YARD = 25 FT
 REAR YARD = 30 FT
 SIDE YARD = 5 FT

SURVEY REQUESTED BY:

MIDWEST DEVELOPMENT CO.
 411 FIRST AVENUE SE
 CEDAR RAPIDS, IOWA

CLOSURE:

- ALL SUBDIVISION BOUNDARIES ARE WITHIN THE 1:10,000 ERROR OF CLOSURE REQUIREMENT
- ALL LOTS ARE WITHIN THE 1:5000 ERROR OF CLOSURE REQUIREMENT.

TRACT SUMMARY:

TRACT A - ROAD RIGHT-OF-WAY

SHEET INDEX

SHEET 1	TITLE SHEET
SHEET 2	OVERALL LAYOUT
SHEET 3	FINAL PLAT
SHEET 4	FINAL PLAT

OWNERS OF RECORD

MIDWEST DEVELOPMENT CO.
 411 FIRST AVENUE SE
 CEDAR RAPIDS, IOWA

FLOOD ZONE

(ZONE X)
 PANEL #19013C0145F
 AND
 PANEL #19013C0163F
 EFFECTIVE DATE: JULY 18, 2011

PREPARED DATE:

JANUARY 10, 2022

BENCH MARK

ELEV = 975.45
 AERIAL SERVICE GPS CONTROL MONUMENT #93 ON THE WEST SIDE OF UNION ROAD, APPROX 277 FEET NORTH OF WILD HORSE DRIVE & UNION ROAD INTERSECTION.

NOTE:

BEARINGS ARE BASED ON THE EAST LINE OF THE NORTHEAST 1/4 OF SECTION 16, TOWNSHIP 89 NORTH, RANGE 14 WEST OF THE FIFTH PRINCIPAL MERIDIAN BEARING NORTH 00°00'09" WEST

AREA:

8.13 ACRES

MAILBOX NOTES:

ALL MAILBOXES SHALL MEET USPS STANDARDS. CONTRACTOR SHALL COORDINATE WITH CITY OF CEDAR FALLS PRIOR TO INSTALLATION.

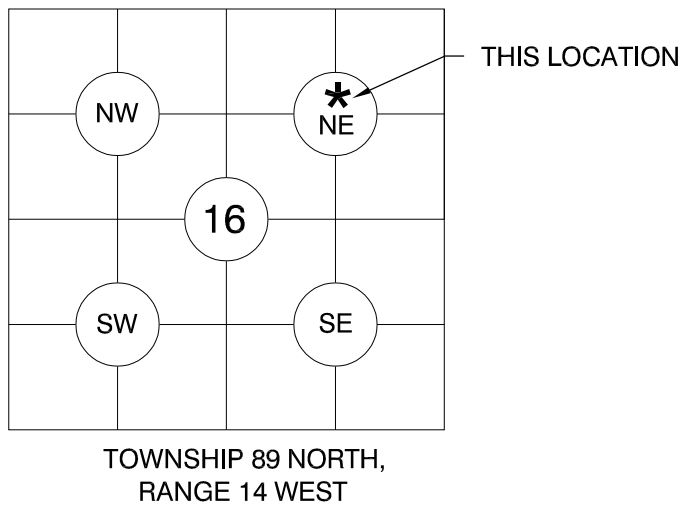

LOT TABLE

LOT	ACRES	SQ FT
1	0.45	19,486
2	0.37	16,044
3	0.36	15,870
4	0.36	15,505
5	0.36	15,590
6	0.35	15,353
7	0.47	20,646
8	0.45	19,531
9	0.45	19,688
10	0.36	15,622
11	0.27	11,652
12	0.26	11,445
13	0.24	10,499
14	0.27	11,862
15	0.28	12,019
16	0.31	13,352
17	0.31	13,564
18	0.34	14,685
19	0.33	14,264
TRACT "A"	1.54	67,299

	(GROSS-ACRES)	(EASE-ACRES)	(NET-ACRES)
NE1/4 NE1/4 SEC 16-89-14	1.65 AC	0.29 AC	1.36 AC
NW1/4 NE1/4 SEC 16-89-14	0.25 AC	0.00 AC	0.25 AC
SE1/4 NE1/4 SEC 16-89-14	2.00 AC	0.21 AC	1.79 AC
SW1/4 NE1/4 SEC 16-89-14	4.23 AC	1.05 AC	3.18 AC
TOTAL	8.13 AC	1.55 AC	6.58 AC

LEGEND:

- ▲ GOVERNMENT CORNER MONUMENT FOUND
- △ GOVERNMENT CORNER MONUMENT SET 1/2" x 30" REBAR w/ORANGE PLASTIC ID CAP #17162
- PARCEL OR LOT CORNER MONUMENT FOUND
- SET 1/2" x 30" REBAR w/ORANGE PLASTIC ID CAP #17162
- () RECORDED AS

**FINAL PLAT
WILD HORSE RIDGE
FIFTH ADDITION**

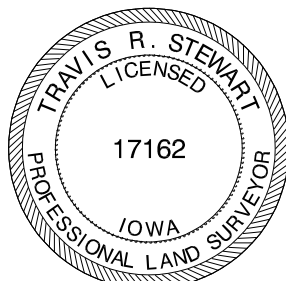

I hereby certify that this land surveying document was prepared and the related survey work was performed by me or under my direct personal supervision and that I am a duly Licensed Professional Land Surveyor under the laws of the State of Iowa.

Travis R. Stewart 7-20-2022
 Travis R. Stewart, PLS date
 Iowa License Number 17162
 My License Renewal Date is December 31, 2023
 Pages or sheets covered by this seal: _____
 SHEETS 1 OF 4, 2 OF 4, 3 OF 4 AND 4 OF 4



Clapsaddle-Garber Associates, Inc.
 16 East Main Street
 Marshalltown, Iowa 50158
 Ph 641-752-6701
 www.cgaconsultants.com

DRAWN CAQ	SHEET NO. 1 OF 4
DATE 3-5-2022	PROJECT NO. 5805.05

FINAL PLAT WILD HORSE RIDGE FIFTH ADDITION CEDAR FALLS, IOWA

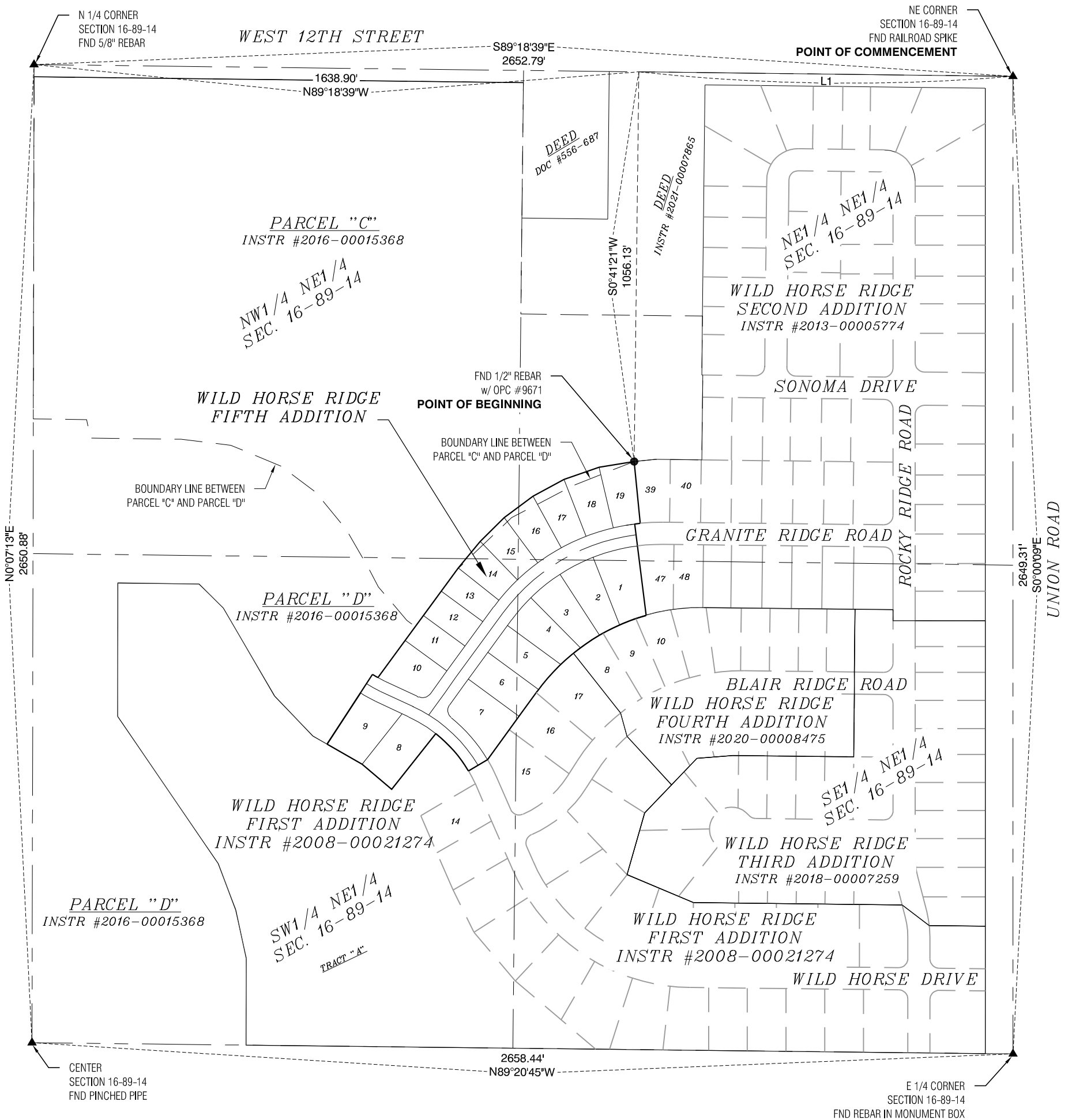

DESCRIPTION

A CERTAIN PARCEL OF LAND LOCATED IN PART OF PARCEL "C" AND IN PART OF PARCEL "D" OF A PLAT OF SURVEY FILED ON DOCUMENT NO. 2016-00015368 IN THE OFFICE OF THE RECORDER, BLACK HAWK COUNTY AND BEING PART OF THE NORTHWEST 1/4 OF THE NORTHEAST 1/4, THE NORTHEAST 1/4 OF THE NORTHEAST 1/4, THE SOUTHWEST 1/4 OF THE NORTHEAST 1/4 AND THE SOUTHEAST 1/4 OF THE NORTHEAST 1/4 ALL IN SECTION 16, TOWNSHIP 89 NORTH, RANGE 14 WEST OF THE 5TH P.M., IN THE CITY OF CEDAR FALLS, BLACK HAWK COUNTY, IOWA.

MORE PARTICULARLY DESCRIBED AS FOLLOWS: COMMENCING AT THE NORTHEAST CORNER SECTION 16, TOWNSHIP 89 NORTH, RANGE 14 WEST OF THE 5TH P.M.; THENCE, N89°18'39"W 1013.89' ALONG THE NORTH LINE OF NORTHEAST 1/4 OF THE NORTHEAST 1/4 OF SAID SECTION 16; THENCE, S0°41'21"W 1056.13' TO THE NORTHWESTERLY CORNER OF LOT 39 OF WILD HORSE RIDGE SECOND ADDITION, RECORDED ON DOCUMENT NO. 2013-00005774 IN THE OFFICE OF THE RECORDER, BLACK HAWK COUNTY AND SAID POINT BEING THE POINT OF BEGINNING; THENCE, S5°37'33"E 168.00' ALONG A WEST LINE OF SAID LOT 39 TO THE SOUTHWESTERLY CORNER OF SAID LOT 39, SAID POINT ALSO BEING ON THE NORTH RIGHT OF WAY LINE OF GRANITE RIDGE ROAD; THENCE, SOUTHWESTERLY 15.09' ALONG A 560.00' RADIUS CURVE, CONCAVE SOUTHEASTERLY HAVING A CHORD BEARING OF S83°36'08"W AND A CHORD DISTANCE OF 15.09' ALONG SAID NORTH RIGHT OF WAY LINE OF GRANITE RIDGE ROAD TO A WESTERLY CORNER OF SAID WILD HORSE RIDGE SECOND ADDITION; THENCE, S7°10'12"E 249.67' ALONG A WESTERLY LINE OF SAID WILD HORSE RIDGE SECOND ADDITION TO THE SOUTHWESTERLY CORNER OF LOT 47 OF SAID WILD HORSE RIDGE SECOND ADDITION, SAID POINT ALSO BEING ON A NORTHERLY LINE OF WILD HORSE RIDGE FOURTH ADDITION RECORDED ON INSTRUMENT NO. 2020-00008475 IN THE OFFICE OF THE RECORDER BLACK HAWK COUNTY; THENCE, SOUTHWESTERLY 371.49' ALONG A 550.00' RADIUS CURVE, CONCAVE SOUTHEASTERLY HAVING A CHORD BEARING S54°50'18"W AND A CHORD DISTANCE OF 364.47' ALONG THE NORTHERLY LINE OF SAID WILD HORSE RIDGE FOURTH ADDITION AND NORTHERLY LINE OF WILD HORSE RIDGE FIRST ADDITION, RECORDED ON INSTRUMENT NO. 2008-00021274 IN THE OFFICE OF THE RECORDER, BLACK HAWK COUNTY; THENCE, S36°00'48"W 84.21' ALONG A NORTHWESTERLY LINE OF SAID WILD HORSE RIDGE FIRST ADDITION; THENCE, S36°00'48"W 145.02' ALONG WESTERLY LINE OF SAID WILD HORSE RIDGE FIRST ADDITION TO A POINT ON THE NORTHEASTERLY RIGHT OF WAY LINE OF WILD HORSE DRIVE; THENCE, S59°18'03"W 60.00' ALONG A WESTERLY LINE OF SAID WILD HORSE RIDGE FIRST ADDITION TO A POINT ON THE SOUTHWESTERLY RIGHT OF WAY LINE OF WILD HORSE DRIVE; THENCE, NORTHWESTERLY 135.29' ALONG THE ARC OF A 370.00' RADIUS CURVE, CONCAVE SOUTHWESTERLY, HAVING A CHORD BEARING OF N41°10'28"W AND A CHORD DISTANCE OF 134.54' ALONG SAID SOUTHWESTERLY RIGHT OF WAY LINE; THENCE, S38°21'01"W 192.77' ALONG A WESTERLY LINE OF SAID WILD HORSE RIDGE FIRST ADDITION; THENCE, N49°49'03"W 105.00' ALONG A NORTHERLY LINE OF SAID WILD HORSE RIDGE FIRST ADDITION; THENCE, N60°07'44"W 109.52' ALONG A NORTHERLY LINE OF SAID WILD HORSE RIDGE FIRST ADDITION; THENCE, N33°05'13"E 225.59' TO A POINT ON THE NORTHERLY RIGHT OF WAY LINE OF WILD HORSE DRIVE; THENCE, SOUTHEASTERLY 16.95' ALONG A 270.00' RADIUS CURVE, CONCAVE NORTHEASTERLY, HAVING A CHORD BEARING OF S58°42'40"E AND A CHORD DISTANCE OF 16.94' ALONG SAID NORTHERLY RIGHT OF WAY LINE; THENCE, N36°16'01"E 368.69'; THENCE, N39°26'18"E 93.50'; THENCE, N45°25'18"E 91.41'; THENCE, N53°11'55"E 97.37'; THENCE, N61°39'21"E 95.21'; THENCE, N70°48'25"E 100.44'; THENCE, N80°39'55"E 96.56' TO THE POINT OF BEGINNING, CONTAINING 8.13 ACRES. SUBJECT TO EASEMENTS AND RESTRICTIONS OF RECORD, IF ANY.

LINE DATA		
LINE NUMBER	BEARING	DISTANCE
L1	N89°18'39"W	1013.89'

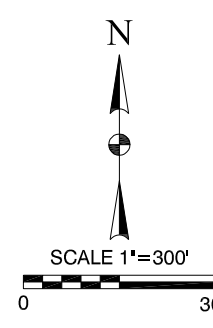

Clapsaddle-Garber Associates, Inc
16 East Main Street
Marshalltown, Iowa 50158
Ph 641-752-6701
www.cgaconsultants.com

DRAWN CAQ	SHEET NO. 2 OF 4
DATE 3-5-2022	PROJECT NO. 5805.05

FINAL PLAT WILD HORSE RIDGE FIFTH ADDITION CEDAR FALLS, IOWA

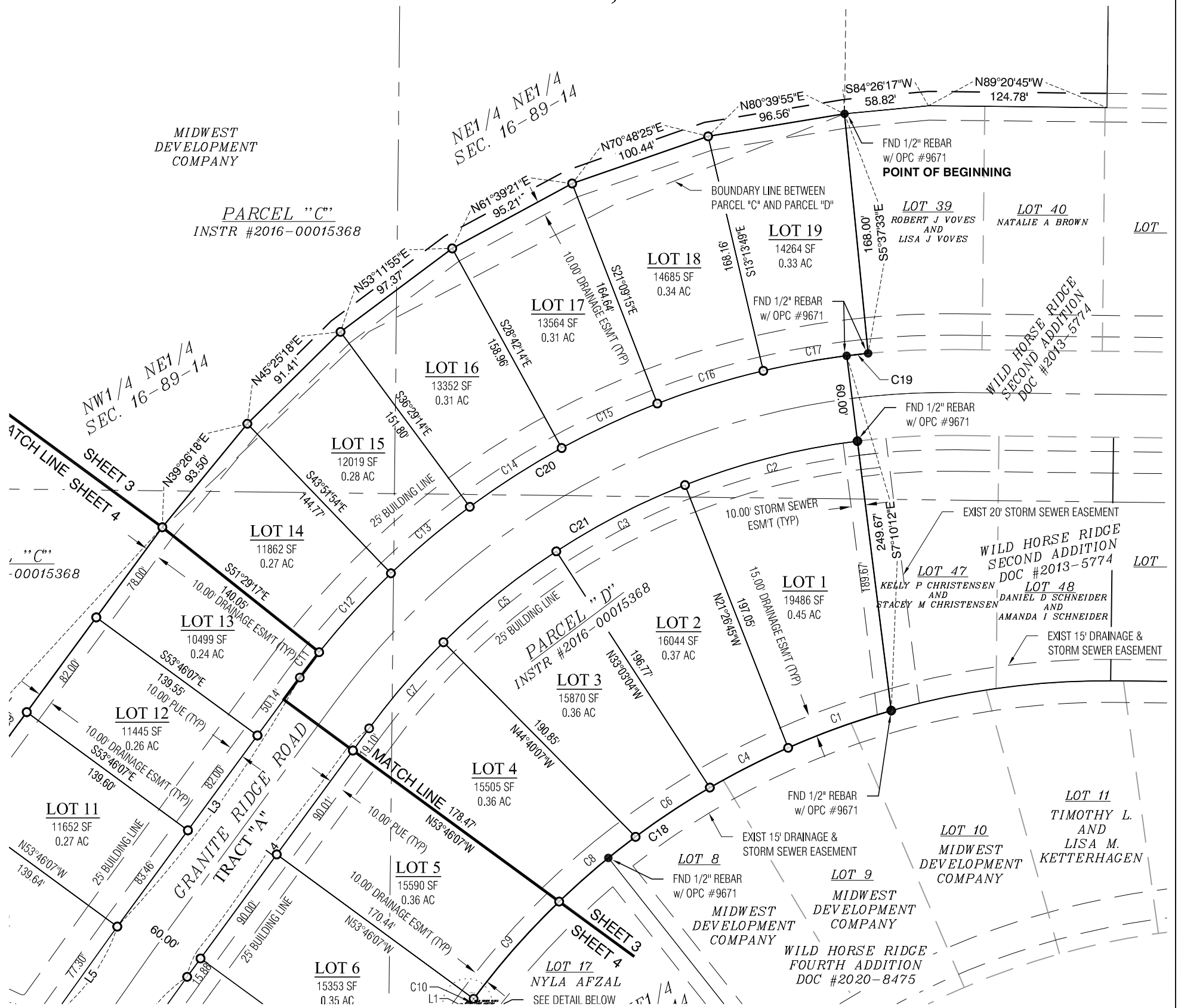

Curve Table

CURVE DATA	ARC LENGTH	RADIUS	DELTA ANGLE	CHORD BEARING	CHORD
C1	76.62'	550.00'	7°58'54"	S70°11'50"W	76.56'
C2	124.58'	500.00'	14°16'33"	S75°41'31"W	124.26'
C3	101.27'	500.00'	11°36'18"	S62°45'06"W	101.10'
C4	61.32'	550.00'	6°23'15"	S63°00'45"W	61.29'
C5	101.38'	500.00'	11°37'04"	S51°08'24"W	101.21'
C6	62.29'	550.00'	6°29'21"	S56°34'26"W	62.26'
C7	79.41'	500.00'	9°06'00"	S40°46'53"W	79.33'
C8	69.96'	550.00'	7°17'18"	S49°41'07"W	69.92'
C9	90.47'	550.00'	9°25'28"	S41°19'44"W	90.37'
C10	5.79'	550.00'	0°36'11"	S36°18'54"W	5.79'
C11	22.29'	560.00'	2°16'50"	S37°22'18"W	22.29'
C12	74.51'	560.00'	7°37'23"	S42°19'24"W	74.45'
C13	72.11'	560.00'	7°22'40"	S49°49'26"W	72.06'
C14	76.07'	560.00'	7°47'00"	S57°24'16"W	76.01'
C15	73.79'	560.00'	7°32'59"	S65°04'16"W	73.74'
C16	77.45'	560.00'	7°55'26"	S72°48'28"W	77.38'
C17	74.32'	560.00'	7°36'16"	S80°34'19"W	74.27'

Curve Table

CURVE DATA	ARC LENGTH	RADIUS	DELTA ANGLE	CHORD BEARING	CHORD
C18	371.49'	550.00'	38°41'59"	S54°50'18"W	364.47'
C19	15.09'	560.00'	1°32'39"	S83°36'08"W	15.09'
C20	455.45'	560.00'	46°35'55"	S59°31'51"W	443.00'
C21	406.65'	500.00'	46°35'55"	S59°31'51"W	395.53'
C22	151.49'	430.00'	20°11'07"	N40°47'30"W	150.71'
C23	37.76'	25.00'	86°32'16"	S7°36'56"E	34.27'
C24	34.71'	25.00'	79°32'58"	N75°25'46"E	31.99'
C25	1.99'	430.00'	0°15'53"	N64°55'42"W	1.99'
C26	21.45'	270.00'	4°33'05"	S62°47'06"E	21.44'
C27	46.93'	330.00'	8°08'51"	S60°59'13"E	46.89'
C28	86.60'	370.00'	13°24'39"	N58°21'19"W	86.41'
C29	16.95'	270.00'	3°35'46"	S58°42'40"E	16.94'
C30	135.29'	370.00'	20°57'03"	N41°10'28"W	134.54'
C31	33.80'	430.00'	4°30'13"	N32°45'03"W	33.79'

LINE DATA

LINE NUMBER	BEARING	DISTANCE
L1	S36°00'48"W	5.04'
L2	S35°38'55"W	70.58'
L3	N36°13'57"E	215.60'
L4	N36°14'03"E	214.99'
L5	S35°38'56"W	77.30'
L6	N65°03'38"W	99.08'
L7	S65°03'38"E	99.08'
L8	N57°01'16"E	56.12'

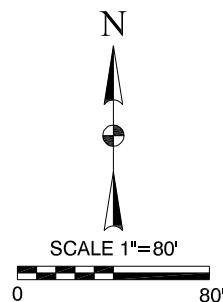

Clapsaddle-Garber Associates, Inc
16 East Main Street
Marshalltown, Iowa 50158
Ph 641-752-6701
www.cgaconsultants.com

DRAWN CAQ	SHEET NO. 3 OF 4
DATE 3-5-2022	PROJECT NO. 5805.05

FINAL PLAT WILD HORSE RIDGE FIFTH ADDITION CEDAR FALLS, IOWA

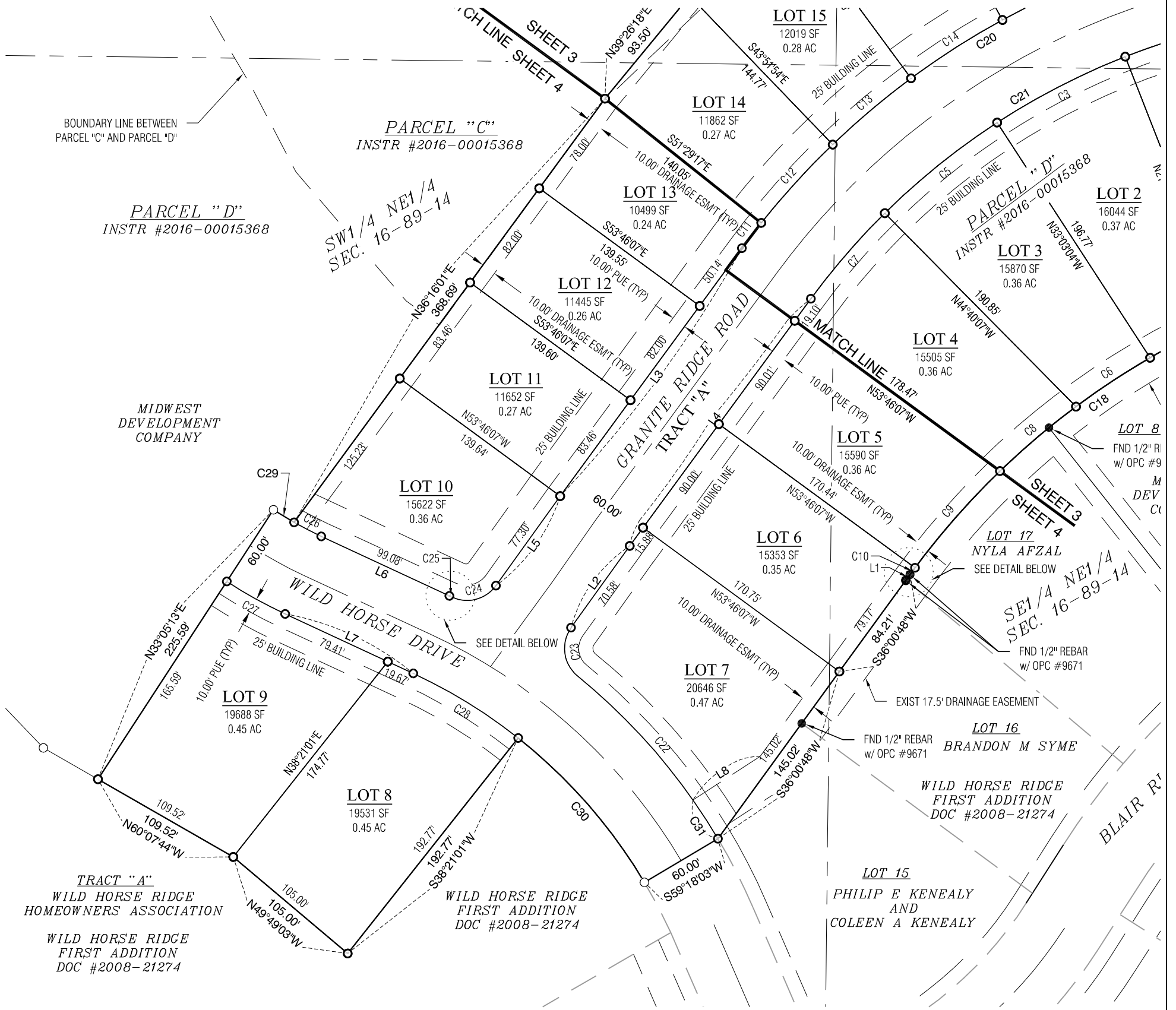

Curve Table

CURVE DATA	ARC LENGTH	RADIUS	DELTA ANGLE	CHORD BEARING	CHORD
C1	76.62'	550.00'	7°58'54"	S70°11'50"W	76.56'
C2	124.58'	500.00'	14°16'33"	S75°41'31"W	124.26'
C3	101.27'	500.00'	11°36'18"	S62°45'06"W	101.10'
C4	61.32'	550.00'	6°23'15"	S63°00'45"W	61.29'
C5	101.38'	500.00'	11°37'04"	S51°08'24"W	101.21'
C6	62.29'	550.00'	6°29'21"	S56°34'26"W	62.26'
C7	79.41'	500.00'	9°06'00"	S40°46'53"W	79.33'
C8	69.96'	550.00'	7°17'18"	S49°41'07"W	69.92'
C9	90.47'	550.00'	9°25'28"	S41°19'44"W	90.37'
C10	5.79'	550.00'	0°36'11"	S36°18'54"W	5.79'
C11	22.29'	560.00'	2°16'50"	S37°22'18"W	22.29'
C12	74.51'	560.00'	7°37'23"	S42°19'24"W	74.45'
C13	72.11'	560.00'	7°22'40"	S49°49'26"W	72.06'
C14	76.07'	560.00'	7°47'00"	S57°24'16"W	76.01'
C15	73.79'	560.00'	7°32'59"	S65°04'16"W	73.74'
C16	77.45'	560.00'	7°55'26"	S72°48'28"W	77.38'
C17	74.32'	560.00'	7°36'16"	S80°34'19"W	74.27'

Curve Table

CURVE DATA	ARC LENGTH	RADIUS	DELTA ANGLE	CHORD BEARING	CHORD
C18	371.49'	550.00'	38°41'59"	S54°50'18"W	364.47'
C19	15.09'	560.00'	1°32'39"	S83°36'08"W	15.09'
C20	455.45'	560.00'	46°35'55"	S59°31'51"W	443.00'
C21	406.65'	500.00'	46°35'55"	S59°31'51"W	395.53'
C22	151.49'	430.00'	20°11'07"	N40°47'30"W	150.71'
C23	37.76'	25.00'	86°32'16"	S7°36'56"E	34.27'
C24	34.71'	25.00'	79°32'58"	N75°25'46"E	31.99'
C25	1.99'	430.00'	0°15'53"	N64°55'42"W	1.99'
C26	21.45'	270.00'	4°33'05"	S62°47'06"E	21.44'
C27	46.93'	330.00'	8°08'51"	S60°59'13"E	46.89'
C28	86.60'	370.00'	13°24'39"	N58°21'19"W	86.41'
C29	16.95'	270.00'	3°35'46"	S58°42'40"E	16.94'
C30	135.29'	370.00'	20°57'03"	N41°10'28"W	134.54'
C31	33.80'	430.00'	4°30'13"	N32°45'03"W	33.79'

LINE DATA

LINE NUMBER	BEARING	DISTANCE
L1	S36°00'48"W	5.04'
L2	S35°38'55"W	70.58'
L3	N36°13'57"E	215.60'
L4	N36°14'03"E	214.99'
L5	S35°38'56"W	77.30'
L6	N65°03'38"W	99.08'
L7	S65°03'38"E	99.08'
L8	N57°01'16"E	56.12'

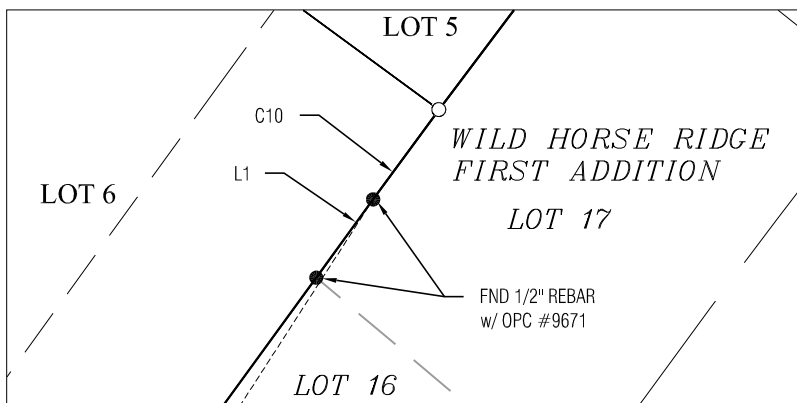
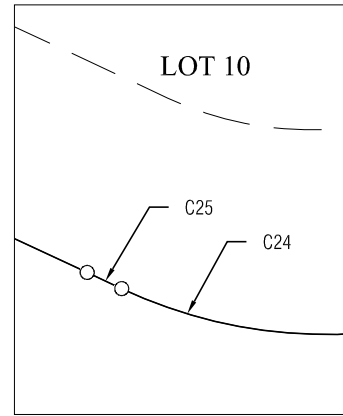

Clapsaddle-Garber Associates, Inc
16 East Main Street
Marshalltown, Iowa 50158
Ph 641-752-6701
www.cgaconsultants.com

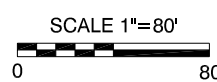

DRAWN CAQ	SHEET NO. 4 OF 4
DATE 3-5-2022	PROJECT NO. 5805.05

SURETY BOND NO. IAC593294MAINTENANCE BOND

KNOW ALL BY THESE PRESENTS:

That we, Midwest Development Company, as Principal (hereinafter the "Principal") and Merchants Bonding Company (Mutual), as Surety are held and firmly bound unto the City of Cedar Falls, Iowa, as Obligee (hereinafter referred to as "the City"), and to all persons who may be injured by any breach of any of the conditions of this Bond in the amount of six hundred seventy-three thousand two hundred sixty-eight dollars (\$673,268.00), lawful money of the United States, for the payment of which sum, well and truly to be made, we bind ourselves, our heirs, legal representatives and assigns, jointly or severally, firmly by these presents.

Whereas, prior to City Council approval of a final plat of a subdivided area, the Principal shall submit to the City engineer this maintenance bond to provide for the protection of the City against future liability for any and all defects in workmanship or materials and any conditions that could result in structural or other failure of all of the public infrastructure improvements required as part of final plat approval for a period of three (3) years from the date of acceptance of any required public improvement which is the day of , ; and

Whereas, the Principal represents that it has constructed and installed all required public infrastructure improvements as required as part of the final plat approval, to conform with approved construction plans which meet the design standards and technical standards established for such public improvements by the City and by Cedar Falls Utilities, and as shown on the approved construction plans and described in detail as follows:

Earthwork, Sewers and Drains, Water Main and Appurtenances, Structures for Sanitary and Storm Sewers, Streets and Related Work, Traffic Control, Site Work and Landscaping

Now therefore, it is expressly understood and agreed by the Principal and Surety in this bond that the following provisions are a part of this Bond and are binding upon said Principal and Surety, to-wit:

1. MAINTENANCE: The Principal and Surety on this Bond hereby agree, at their own expense:
 - A. To remedy any and all defects that may develop in or result from work performed on the above described public infrastructure improvements required as part of final plat approval for a period of three (3) years from the date of acceptance of all required public infrastructure improvements, by reason of defects in workmanship or materials used in construction of said work;
 - B. To keep all work in continuous good repair; and
 - C. To pay the City's reasonable costs of monitoring and inspection to assure that any defects are remedied, and to repay the City all outlay and expense incurred as a result of Principal's and Surety's failure to remedy any defect as required by this section.
 - D. Following Principal and Surety's repair and construction of any failed infrastructure component or elements the city engineer shall determine whether the three-year bond shall be renewed or extended beyond the original three-year bond period. In the event of major structural failures the maintenance bond shall be renewed if recommended by the city engineer for a new three-year period from the date of repair for that portion of the public

improvements involved in the structural failure and repair

2. GENERAL: Every Surety on this Bond shall be deemed and held bound, any contract to the contrary notwithstanding, to the following provisions:

- A. That this Bond shall remain in full force and effect until the maintenance period is completed, whether completed within the specified three (3) year period or within an extension thereof, as provided in Section I-D.
- B. That no provision of this Bond or of any other contract shall be valid that limits to less than five years after the date of acceptance the right to sue on this Bond.
- C. That as used herein, the phrase "all outlay and expense" is not to be limited in any way, but shall include the actual and reasonable costs and expenses incurred by the City including interest, benefits, and overhead where applicable. Accordingly, "all outlay and expense" would include but not be limited to all contract or employee expense, all equipment usage or rental, materials, testing, outside experts, attorney's fees (including overhead expenses of the City's staff attorneys), and all costs and expenses of litigation as they are incurred by the City. It is intended the Principal and Surety will defend and indemnify the City on all claims made against the City on account of Principal's failure to perform as required in this bond, that all agreements and promises set forth in this Bond will be fulfilled, and that the City will be fully indemnified so that it will be put into the position it would have been in had the infrastructure improvements been constructed in the first instance as required.
- D. In the event the City incurs any "outlay and expense" in defending itself against any claim as to which the Principal or Surety should have provided the defense, or in the enforcement of the promises given by the Principal in the approved construction plans, or in the enforcement of the promises given by the Principal and Surety in this Bond, the Principal and Surety agree that they will make the City whole for all such outlay and expense, provided that the Surety's obligation under this bond shall not exceed 125% of the penal sum of this bond.

In the event that any actions or proceedings are initiated regarding this Bond, the parties agree that the venue thereof shall be the United States District Court for the Northern District of Iowa or the Iowa District Court for Black Hawk County, State of Iowa. If legal action is required by the City to enforce the provisions of this Bond or to collect the monetary obligation incurring to the benefit of the City, the Principal and the Surety agree, jointly, and severally, to pay the City all outlay and expense incurred therefor by the City. All rights, powers, and remedies of the City hereunder shall be cumulative and not alternative and shall be in addition to all rights, powers, and remedies given to the City, by law. The City may proceed against surety for any amount guaranteed hereunder whether action is brought against the Principal or whether Principal is joined in any such action(s) or not.

NOW THEREFORE, the condition of this obligation is such that if said Principal shall faithfully perform all the promises of the Principal, as set forth and provided in the approved construction plans and in this Bond, then this obligation shall be null and void, otherwise it shall remain in full force and effect.

When a work, term, or phrase is used in this Bond, it shall be interpreted or construed first as defined in this Bond and the approved construction plans; second, if not defined in the Bond and the approved construction plans, it shall be interpreted or construed as defined in applicable provisions of the Iowa Code; third, if not defined in the Iowa Code, it shall be interpreted or construed according to its generally accepted meaning in the construction industry; and fourth, if it has no generally accepted meaning in the construction industry, it

shall be interpreted or construed according to its common or customary usage.

Failure to specify or particularize shall not exclude terms or provisions not mentioned and shall not limit liability hereunder. The approved construction plans are hereby made a part of this bond.

Witness our hands, in triplicate, this 8th day of August, 2022.

Countersigned By:

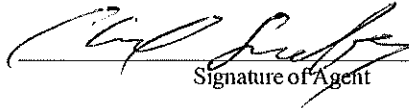
Signature of Agent

Chad Smeby
Printed Name of Agent

Skogman Insurance
Company Name

1110 Dina CT STE B
Company Address

Hiawatha, IA 52233
City, State, Zip Code

319-366-6288
Company Telephone Number

PRINCIPAL:

Midwest Development Company
Principal

By: 
Signature

Hunter Skogman President Land Acquisition ar
Title

SURETY:

Merchants Bonding Company (Mutual)
Surety Company

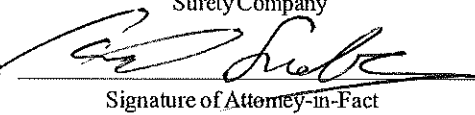
By: 
Signature of Attorney-in-Fact

Chad Smeby
Printed Name of Attorney-in-Fact

Merchants Bonding Company (Mutual)
Company Name

P.O. Box 14498
Company Address

Des Moines IA 50306-3498
City, State, Zip Code

(800) 678-8171
Company Telephone Number

NOTE:

MERCHANTS
BONDING COMPANY™
POWER OF ATTORNEY

Item 19.

Know All Persons By These Presents, that MERCHANTS BONDING COMPANY (MUTUAL) and MERCHANTS NATIONAL BONDING, INC., both being corporations of the State of Iowa (herein collectively called the "Companies") do hereby make, constitute and appoint, individually,

Chad Smeby

their true and lawful Attorney(s)-in-Fact, to sign its name as surety(ies) and to execute, seal and acknowledge any and all bonds, undertakings, contracts and other written instruments in the nature thereof, on behalf of the Companies in their business of guaranteeing the fidelity of persons, guaranteeing the performance of contracts and executing or guaranteeing bonds and undertakings required or permitted in any actions or proceedings allowed by law.

This Power-of-Attorney is granted and is signed and sealed by facsimile under and by authority of the following By-Laws adopted by the Board of Directors of Merchants Bonding Company (Mutual) on April 23, 2011 and amended August 14, 2015 and adopted by the Board of Directors of Merchants National Bonding, Inc., on October 16, 2015.

"The President, Secretary, Treasurer, or any Assistant Treasurer or any Assistant Secretary or any Vice President shall have power and authority to appoint Attorneys-in-Fact, and to authorize them to execute on behalf of the Company, and attach the seal of the Company thereto, bonds and undertakings, recognizances, contracts of indemnity and other writings obligatory in the nature thereof."

"The signature of any authorized officer and the seal of the Company may be affixed by facsimile or electronic transmission to any Power of Attorney or Certification thereof authorizing the execution and delivery of any bond, undertaking, recognizance, or other suretyship obligations of the Company, and such signature and seal when so used shall have the same force and effect as though manually fixed."

In connection with obligations in favor of the Florida Department of Transportation only, it is agreed that the power and authority hereby given to the Attorney-in-Fact includes any and all consents for the release of retained percentages and/or final estimates on engineering and construction contracts required by the State of Florida Department of Transportation. It is fully understood that consenting to the State of Florida Department of Transportation making payment of the final estimate to the Contractor and/or its assignee, shall not relieve this surety company of any of its obligations under its bond.

In connection with obligations in favor of the Kentucky Department of Highways only, it is agreed that the power and authority hereby given to the Attorney-in-Fact cannot be modified or revoked unless prior written personal notice of such intent has been given to the Commissioner-Department of Highways of the Commonwealth of Kentucky at least thirty (30) days prior to the modification or revocation.

In Witness Whereof, the Companies have caused this instrument to be signed and sealed this 8th day of August, 2022.

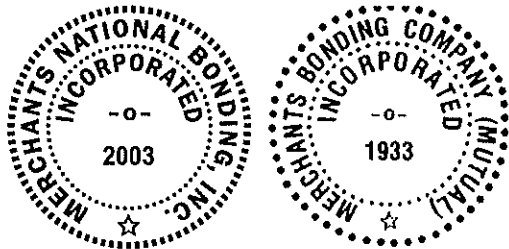

MERCHANTS BONDING COMPANY (MUTUAL)
MERCHANTS NATIONAL BONDING, INC.

By *Larry Taylor*
President

STATE OF IOWA
COUNTY OF DALLAS ss.

On this 8th day of August, 2022, before me appeared Larry Taylor, to me personally known, who being by me duly sworn did say that he is President of MERCHANTS BONDING COMPANY (MUTUAL) and MERCHANTS NATIONAL BONDING, INC.; and that the seals affixed to the foregoing instrument are the Corporate Seals of the Companies; and that the said instrument was signed and sealed in behalf of the Companies by authority of their respective Boards of Directors.

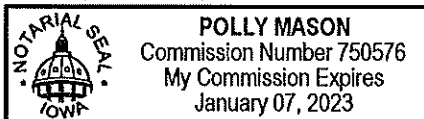

Polly Mason

Notary Public

(Expiration of notary's commission
does not invalidate this instrument)

I, William Warner, Jr., Secretary of MERCHANTS BONDING COMPANY (MUTUAL) and MERCHANTS NATIONAL BONDING, INC., do hereby certify that the above and foregoing is a true and correct copy of the POWER-OF-ATTORNEY executed by said Companies, which is still in full force and effect and has not been amended or revoked.

In Witness Whereof, I have hereunto set my hand and affixed the seal of the Companies on this 8th day of August, 2022.

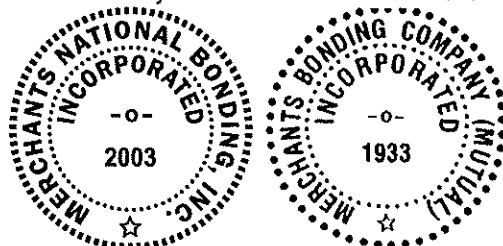

William Warner Jr.
Secretary

MERCHANTS
BONDING COMPANY™
POWER OF ATTORNEY

Know All Persons By These Presents, that MERCHANTS BONDING COMPANY (MUTUAL) and MERCHANTS NATIONAL BONDING, INC., both being corporations of the State of Iowa (herein collectively called the "Companies") do hereby make, constitute and appoint, individually,

Chad Smeby

their true and lawful Attorney(s)-in-Fact, to sign its name as surety(ies) and to execute, seal and acknowledge any and all bonds, undertakings, contracts and other written instruments in the nature thereof, on behalf of the Companies in their business of guaranteeing the fidelity of persons, guaranteeing the performance of contracts and executing or guaranteeing bonds and undertakings required or permitted in any actions or proceedings allowed by law.

This Power-of-Attorney is granted and is signed and sealed by facsimile under and by authority of the following By-Laws adopted by the Board of Directors of Merchants Bonding Company (Mutual) on April 23, 2011 and amended August 14, 2015 and adopted by the Board of Directors of Merchants National Bonding, Inc., on October 16, 2015.

"The President, Secretary, Treasurer, or any Assistant Treasurer or any Assistant Secretary or any Vice President shall have power and authority to appoint Attorneys-in-Fact, and to authorize them to execute on behalf of the Company, and attach the seal of the Company thereto, bonds and undertakings, recognizances, contracts of indemnity and other writings obligatory in the nature thereof."

"The signature of any authorized officer and the seal of the Company may be affixed by facsimile or electronic transmission to any Power of Attorney or Certification thereof authorizing the execution and delivery of any bond, undertaking, recognizance, or other suretyship obligations of the Company, and such signature and seal when so used shall have the same force and effect as though manually fixed."

In connection with obligations in favor of the Florida Department of Transportation only, it is agreed that the power and authority hereby given to the Attorney-in-Fact includes any and all consents for the release of retained percentages and/or final estimates on engineering and construction contracts required by the State of Florida Department of Transportation. It is fully understood that consenting to the State of Florida Department of Transportation making payment of the final estimate to the Contractor and/or its assignee, shall not relieve this surety company of any of its obligations under its bond.

In connection with obligations in favor of the Kentucky Department of Highways only, it is agreed that the power and authority hereby given to the Attorney-in-Fact cannot be modified or revoked unless prior written personal notice of such intent has been given to the Commissioner-Department of Highways of the Commonwealth of Kentucky at least thirty (30) days prior to the modification or revocation.

In Witness Whereof, the Companies have caused this instrument to be signed and sealed this 8th day of August, 2022.

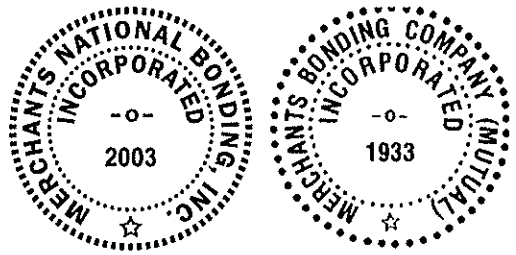

MERCHANTS BONDING COMPANY (MUTUAL)
MERCHANTS NATIONAL BONDING, INC.

By *Larry Taylor*
President

STATE OF IOWA
COUNTY OF DALLAS ss.

On this 8th day of August, 2022, before me appeared Larry Taylor, to me personally known, who being by me duly sworn did say that he is President of MERCHANTS BONDING COMPANY (MUTUAL) and MERCHANTS NATIONAL BONDING, INC.; and that the seals affixed to the foregoing instrument are the Corporate Seals of the Companies; and that the said instrument was signed and sealed in behalf of the Companies by authority of their respective Boards of Directors.

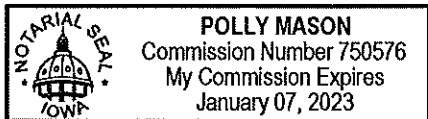

Polly Mason

Notary Public

(Expiration of notary's commission does not invalidate this instrument)

I, William Warner, Jr., Secretary of MERCHANTS BONDING COMPANY (MUTUAL) and MERCHANTS NATIONAL BONDING, INC., do hereby certify that the above and foregoing is a true and correct copy of the POWER-OF-ATTORNEY executed by said Companies, which is still in full force and effect and has not been amended or revoked.

In Witness Whereof, I have hereunto set my hand and affixed the seal of the Companies on this 8th day of August, 2022.

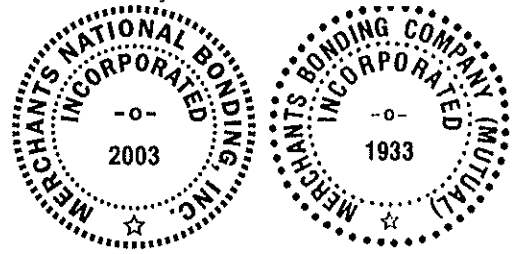

William Warner Jr.
Secretary

FINAL LIEN WAIVER
RELEASE BY CLAIMANTS

The undersigned, having received payment in full for all labor,
Materials, supplies, or equipment supplied to:

Owen Contracting, Inc.

Contractor

Or to any subcontractor/supplier, in the construction or repair of the
Improvements upon the property located at:

Wild Horse Ridge 6th Addition

And furnished in the execution and fulfillment of contract between
Said Contractor and

~~Benton's Ready Mix~~

Subcontractor/Supplier

Dated: 10-31-22

Do (does) hereby release and waiver any and all claims, lien and liens
Right, of any kind, nature, or description what so ever, against said
Property and the owner thereof:



Lienor or Claimant

10-31-22

Date Signed

FINAL LIEN WAIVER
RELEASE BY CLAIMANTS

The undersigned, having received payment in full for all labor,
Materials, supplies, or equipment supplied to:

Owen Contracting, Inc.

Contractor

Or to any subcontractor/supplier, in the construction or repair of the
Improvements upon the property located at:

Wild Horse Ridge 6th Addition

And furnished in the execution and fulfillment of contract between
Said Contractor and

Logan Contractors Supply

Subcontractor/Supplier

Dated: November 3, 2022

Do (does) hereby release and waiver any and all claims, lien and liens
Right, of any kind, nature, or description what so ever, against said
Property and the owner thereof:

Julie Kroll

Julie Kroll, CFO

Lienor or Claimant

November 3, 2022

Date Signed

Invoice #A6836

WAIVER OF LIEN

STATE OF IOWA
COUNTY OF LINN

TO WHOM IT MAY CONCERN:

WHEREAS, the undersigned, **BENTON'S READY MIXED CONCRETE** has been employed by **Rathje Construction Co.** to furnish material and labor for the **Midwest Development – Wild Horse Ridge 6th Addition**

The undersigned, for and in consideration of **Thirteen Thousand Five Hundred Fifty-Four Dollars & 78/100 (\$13,554.78)**

Payment of Invoices: 198225, 198305, 198534, 198591, 198649, 198708, 198765, 198884, 198951, 199027, 199116, 199155, 199213, 201616 & 201719.

and other good and valuable consideration, the receipt whereof is hereby acknowledged, do hereby waive and release any and all lien or claim of, or right to lien under the Statutes of Iowa relating to mechanics' liens on the above-described premises, and the improvements thereon, and on the monies or other considerations due or to become due from the owner, on account of labor, services, material, fixtures, apparatus or machinery heretofore furnished to this date by the undersigned for the above-described premises.

Dated this 29 day of December, 2022.



(Signature of sole owner or authorized representative of corporation or partnership)

SUBCONTRACTOR'S AFFIDAVIT OR CONTRACTOR'S SWORN STATEMENT MUST BE DATED & SIGNED.

JSS (12/27/22)

WAIVER OF LIEN

STATE OF IOWA
COUNTY OF LINN

TO WHOM IT MAY CONCERN:

WHEREAS, the undersigned, BMC AGGREGATES L.C.

has been employed by Rathje Construction Co. to furnish material and labor for the
Midwest Development – Wild Horse Ridge 6th Addition

The undersigned, for and in consideration of

One Hundred Twenty-Four Thousand Six Hundred Thirty-Six Dollars & 70/100
(\$124, 636.70)

Payment of Invoices: 122042, 122209, 122393, 122506, 128462, 129458, 130156, 131056, 132392,
133370, 133371, 133946, 134633, 134634, 135465, 136135, 136739 & 138080.

and other good and valuable consideration, the receipt whereof is hereby acknowledged,
do hereby waive and release any and all lien or claim of, or right to lien under the Statutes of
Iowa relating to mechanics' liens on the above-described premises, and the improvements
thereon, and on the monies or other considerations due or to become due from the owner, on
account of labor, services, material, fixtures, apparatus or machinery heretofore furnished to this
date by the undersigned for the above-described premises.

Dated this 29th day of December, 2022.

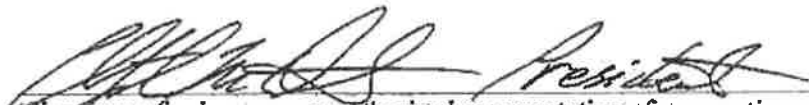
(Signature of sole owner or authorized representative of corporation or partnership)

SUBCONTRACTOR'S AFFIDAVIT OR CONTRACTOR'S SWORN STATEMENT MUST BE
DATED & SIGNED.

JSS (12/27/22)

WAIVER OF LIEN

STATE OF IOWA
COUNTY OF LINN

TO WHOM IT MAY CONCERN:

WHEREAS, the undersigned, **SCHIMBERG COMPANY**
has been employed by **Rafije Construction Co.** to furnish material and labor for the
Midwest Development - Wild Horse Ridge 6th Addition

The undersigned, for and in consideration of

Fifteen Thousand Two Hundred Three Dollars & 41/100
(\$15,203.41)

Payment of Invoices: 813654301, 815262400, 1508600, 819300900, 2074900, 2073900, 819568500, 819568000, 819624600, 2204100, 906821500, 819698000, 819703300, 819707700, 819713300, 819688500, 2177600, 819874100, 2189200, 2190700, 820077100, 906822500, 906823000, 819306600, 820206800, 906828600, 2728700, 906760100, 2763200 & 919707700.

and other good and valuable consideration, the receipt whereof is hereby acknowledged,
do hereby waive and release any and all lien or claim of, or right to lien under the Statutes of
Iowa relating to mechanics' liens on the above-described premises, and the improvements
thereon, and on the monies or other considerations due or to become due from the owner, on
account of labor, services, material, fixtures, apparatus or machinery heretofore furnished to this
date by the undersigned for the above-described premises.

Dated this _____ day of _____, 2022.

(Signature of sole owner or authorized representative of corporation or partnership)

SUBCONTRACTOR'S AFFIDAVIT OR CONTRACTOR'S SWORN STATEMENT MUST BE
DATED & SIGNED.

JSS (12/27/22)

WAIVER OF LIEN

STATE OF IOWA
COUNTY OF LINN

TO WHOM IT MAY CONCERN:

WHEREAS, the undersigned, **WIESER PRECAST, INC.**

has been employed by **Rathje Construction Co.** to furnish material and labor for the
Midwest Development – Wild Horse Ridge 6th Addition

The undersigned, for and in consideration of

**Forty-Two Thousand Eight Hundred Thirty-Six Dollars & 50/100
(\$42,836.50)**

Payment of Invoices: 49933, 49934, 49935, 49936, 49972 & 50252.

and other good and valuable consideration, the receipt whereof is hereby acknowledged,
do hereby waive and release any and all lien or claim of, or right to lien under the Statutes of
Iowa relating to mechanics' liens on the above-described premises, and the improvements
thereon, and on the monies or other considerations due or to become due from the owner, on
account of labor, services, material, fixtures, apparatus or machinery heretofore furnished to this
date by the undersigned for the above-described premises.

Dated this 30th day of December, 2022.

Wieser Precast Inc - Cynthia M Maxwell
(Signature of sole owner or authorized representative of corporation or partnership)

SUBCONTRACTOR'S AFFIDAVIT OR CONTRACTOR'S SWORN STATEMENT MUST BE
DATED & SIGNED.

JSS (12/27/22)

WAIVER OF LIEN

STATE OF IOWA
COUNTY OF LINN

TO WHOM IT MAY CONCERN:

WHEREAS, the undersigned, **SOIL CONCEPTS, INC.**

has been employed by **Rathje Construction Co.** to furnish material and labor for the

Midwest Development – Wild Horse Ridge 6th Addition

The undersigned, for and in consideration of

Seventeen Thousand Six Hundred Eighty-Eight Dollars & 35/100
(\$17,688.35)

Payment of Invoices: 7288/FEB, 7288/FEB, 7288/FEB, 7288/JUN & 7288/AUG.

and other good and valuable consideration, the receipt whereof is hereby acknowledged,
do hereby waive and release any and all lien or claim of, or right to lien under the Statutes of
Iowa relating to mechanics' liens on the above-described premises, and the improvements
thereon, and on the monies or other considerations due or to become due from the owner, on
account of labor, services, material, fixtures, apparatus or machinery heretofore furnished to this
date by the undersigned for the above-described premises.

Dated this 31 day of Dec, 2022.

(Signature of sole owner or authorized representative of corporation or partnership)

SUBCONTRACTOR'S AFFIDAVIT OR CONTRACTOR'S SWORN STATEMENT MUST BE
DATED & SIGNED.

JSS (12/27/22)

Final Lien Waiver
Release By Claimants

The undersigned, having received payment in full for all labor, Materials, supplies, or equipment supplied to:

MIDWEST DEVELOPMENT COMPANY

Or to any subcontractor, in the construction or repair of the Improvements upon the property located at:

WILDHORSE 6th ADDITION, IN THE CITY OF CEDAR FALLS, IOWA

And furnished in the execution and fulfillment of contract between Said contractor and

Owen Contracting, Inc.

Contractor/Supplier

Dated: 10/31/2022

Do (does) hereby release and waiver any and all claims, lien and liens right, of any kind, nature, or description what so ever, against said property and the owner thereof:



Lienor or Claimant

Date Signed: 11/01/22

DEPARTMENT OF PUBLIC WORKS

City of Cedar Falls
 220 Clay Street
 Cedar Falls, Iowa 50613
 Phone: 319-268-5161
 Fax: 319-268-5197
 www.cedarfalls.com

MEMORANDUM
Engineering Division

TO: Honorable Mayor Robert M. Green and City Council

FROM: Matthew Tolan, EI, Civil Engineer II

DATE: January 17, 2022

SUBJECT: Wild Horse Ridge Sixth Addition
 Final Acceptance of Improvements
 Project No. SU – 454 – 3258

Construction work has been completed on the public improvements in the Wild Horse Ridge Sixth Addition. The project was designed by Clapsaddle-Garber Associates, Inc. and has been completed in accordance with the project plans and the City of Cedar Falls Standard Specifications. The project was inspected by the City of Cedar Falls Engineering Division.

The Engineering Division has reviewed and approved the project plans and specifications, inspected the project through the construction process; and has received and reviewed the project reports and certifications. The project documentation is in order and the project is complete and ready for City Council acceptance. Attached are copies of the Maintenance Bonds from the developer, Midwest Development, and the Final Plat for the Wild Horse Ridge Sixth Addition.

The Wild Horse Ridge Sixth Addition has been constructed in reasonable compliance with the project plans and specifications. The Engineering Division recommends that the City Council approve and accept the public improvements for the Wild Horse Ridge Sixth Addition.

Matthew Tolan, EI, Civil Engineer II

January 9, 2023

Date

xc: Chase Schrage, Director of Public Works
 David Wicke, P.E., City Engineer

FINAL PLAT

WILD HORSE RIDGE SIXTH ADDITION

CEDAR FALLS, BLACK HAWK COUNTY, IOWA

JULY 2022

SURVEYOR AND ENGINEER

TRAVIS R. STEWART, P.L.S.
 ADAM DATERS, P.E.
 CLAPSADDLE-GARBER ASSOCIATES
 P.O. BOX 754 - 16 E. MAIN STREET
 MARSHALLTOWN, IOWA 50158
 (641)752-6701

ZONING INFORMATION:

RP (UNLESS NOTED OTHERWISE)

TYPICAL BUILDING SETBACKS

FRONT YARD = 25 FT
 REAR YARD = 30 FT
 SIDE YARD = 5 FT

SURVEY REQUESTED BY:

MIDWEST DEVELOPMENT CO.
 411 FIRST AVENUE SE
 CEDAR RAPIDS, IOWA

CLOSURE:

- ALL SUBDIVISION BOUNDARIES ARE WITHIN THE 1:10,000 ERROR OF CLOSURE REQUIREMENT
- ALL LOTS ARE WITHIN THE 1:5000 ERROR OF CLOSURE REQUIREMENT.

TRACT SUMMARY:

TRACT A - ROAD RIGHT-OF-WAY

SHEET INDEX

SHEET 1	TITLE SHEET
SHEET 2	OVERALL LAYOUT
SHEET 3	FINAL PLAT
SHEET 4	FINAL PLAT

OWNERS OF RECORD

MIDWEST DEVELOPMENT CO.
 411 FIRST AVENUE SE
 CEDAR RAPIDS, IOWA

FLOOD ZONE

(ZONE X)
 PANEL #19013C0145F
 AND
 PANEL #19013C0163F
 EFFECTIVE DATE: JULY 18, 2011

PREPARED DATE:

JULY 5, 2022

BENCH MARK

ELEV = 975.45
 AERIAL SERVICE GPS CONTROL MONUMENT #93 ON THE WEST SIDE OF UNION ROAD, APPROX 277 FEET NORTH OF WILD HORSE DRIVE & UNION ROAD INTERSECTION.

NOTE:

BEARINGS ARE BASED ON THE EAST LINE OF THE NORTHEAST 1/4 OF SECTION 16, TOWNSHIP 89 NORTH, RANGE 14 WEST OF THE FIFTH PRINCIPAL MERIDIAN BEARING NORTH 00°00'09" WEST

AREA:

9.35 ACRES

MAILBOX NOTES:

ALL MAILBOXES SHALL MEET USPS STANDARDS. CONTRACTOR SHALL COORDINATE WITH CITY OF CEDAR FALLS PRIOR TO INSTALLATION.

LOT TABLE

LOT	ACRES	SQ FT
1	0.26	11,283
2	0.25	11,089
3	0.25	10,920
4	0.26	11,480
5	0.27	11,684
6	0.39	16,923
7	0.46	19,951
8	0.45	19,388
9	0.41	17,848
10	0.40	17,608
11	0.41	17,661
12	0.39	17,185
13	0.33	14,400
14	0.29	12,658
15	0.34	14,947
16	0.38	16,710
17	0.44	19,197
18	0.42	18,391
19	0.24	10,260
20	0.24	10,260
21	0.24	10,530
22	0.24	10,558
TRACT "A"	1.99	86,761

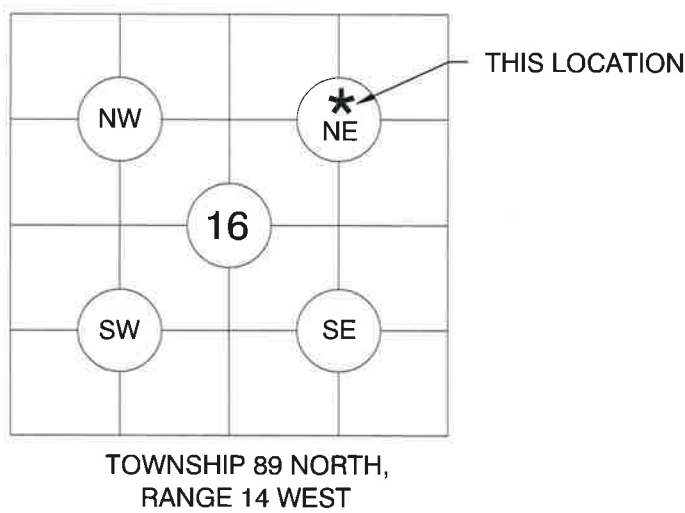

	(GROSS-ACRES)	(EASE-ACRES)	(NET-ACRES)
NW1/4 NE1/4 SEC 16-89-14	4.48 AC	1.06 AC	3.42 AC
SW1/4 NE1/4 SEC 16-89-14	4.88 AC	0.93 AC	3.95 AC
TOTAL	9.36 AC	1.99 AC	7.37 AC

LEGEND:

- ▲ GOVERNMENT CORNER MONUMENT FOUND
- △ GOVERNMENT CORNER MONUMENT SET 1/2" x 30" REBAR w/ORANGE PLASTIC ID CAP #17162
- PARCEL OR LOT CORNER MONUMENT FOUND W/ORANGE PLASTIC ID CAP #17162 UNLESS OTHERWISE NOTED
- SET 1/2" x 30" REBAR w/ORANGE PLASTIC ID CAP #17162
- () RECORDED AS

FINAL PLAT
WILD HORSE RIDGE
SIXTH ADDITION



I hereby certify that this land surveying document was prepared and the related survey work was performed by me or under my direct personal supervision and that I am a duly Licensed Professional Land Surveyor under the laws of the State of Iowa.

Travis R. Stewart 12/21/2022
 Travis R. Stewart, PLS date
 Iowa License Number 17162

My License Renewal Date is December 31, 2023
 Pages or sheets covered by this seal: _____
 SHEETS 1 OF 4, 2 OF 4, 3 OF 4 AND 4 OF 4



Clapsaddle-Garber Associates, Inc
 16 East Main Street
 Marshalltown, Iowa 50158
 Ph 641-752-6701
 www.cgaconsultants.com

DRAWN	SHEET NO.
CAQ	1 OF 4
DATE	PROJECT NO.
7-5-2022	5805.05

FINAL PLAT WILD HORSE RIDGE SIXTH ADDITION CEDAR FALLS, IOWA

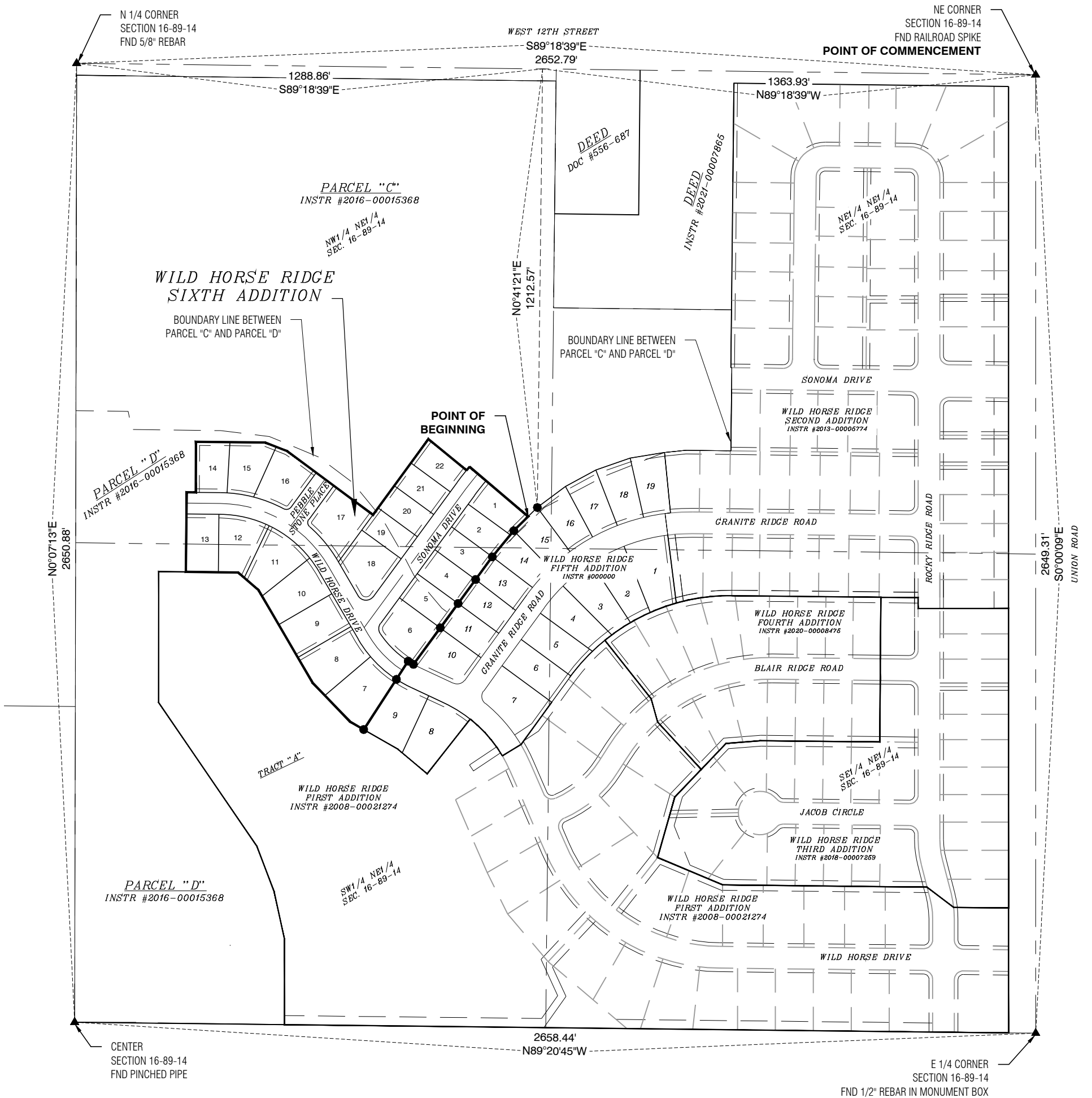

DESCRIPTION

A CERTAIN PARCEL OF LAND LOCATED IN PART OF PARCEL "C" AND IN PART OF PARCEL "D" OF A PLAT OF SURVEY FILED ON DOCUMENT NO. 2016-00015368 IN THE OFFICE OF THE RECORDER, BLACK HAWK COUNTY AND BEING PART OF THE NORTHWEST 1/4 OF THE NORTHEAST 1/4 AND THE SOUTHWEST 1/4 OF THE NORTHEAST 1/4 IN SECTION 16, TOWNSHIP 89 NORTH, RANGE 14 WEST OF THE 5TH P.M., IN THE CITY OF CEDAR FALLS, BLACK HAWK COUNTY, IOWA.

MORE PARTICULARLY DESCRIBED AS FOLLOWS: COMMENCING AT THE NORTHEAST CORNER SECTION 16, TOWNSHIP 89 NORTH, RANGE 14 WEST OF THE 5TH P.M.; THENCE, N89°18'39"W 1363.93' ALONG THE NORTH LINE OF NORTHEAST 1/4 OF SAID SECTION 16; THENCE, S0°41'21"W 1212.57' TO THE NORTHWESTERLY CORNER OF LOT 15 OF WILD HORSE RIDGE FIFTH ADDITION, RECORDED ON DOCUMENT NO. 2023-00006880 IN THE OFFICE OF THE RECORDER, BLACK HAWK COUNTY; THENCE, S45°25'18"W 35.57' ALONG THE NORTHWESTERLY LINE OF SAID LOT 15, SAID POINT ALSO BEING THE POINT OF BEGINNING; THENCE, S45°25'18"W 55.85' ALONG THE NORTHWESTERLY LINE OF SAID LOT 15 TO THE NORTHWESTERLY CORNER OF LOT 14 OF SAID WILD HORSE RIDGE FIFTH ADDITION; THENCE, S39°26'18"W 93.50' ALONG THE NORTHWESTERLY LINE OF SAID LOT 14 TO THE NORTHWESTERLY CORNER OF LOT 13 OF SAID WILD HORSE RIDGE FIFTH ADDITION; THENCE, S36°16'01"W 368.69' ALONG THE NORTHWESTERLY LINE OF LOTS 13, 12, 11 AND 10 OF SAID WILD HORSE RIDGE FIFTH ADDITION TO THE SOUTHWESTERLY CORNER OF LOT 10 OF SAID WILD HORSE RIDGE FIFTH ADDITION, SAID POINT ALSO BEING ON THE NORTHERLY RIGHT OF WAY LINE OF WILD HORSE DRIVE; THENCE, NORTHWESTERLY 16.95' ALONG A 270.00' RADIUS CURVE, CONCAVE NORTHEASTERLY HAVING A CHORD BEARING N58°42'40"W AND A CHORD DISTANCE OF 16.94' ALONG THE NORTHERLY RIGHT OF WAY LINE OF SAID WILD HORSE DRIVE; THENCE, S33°05'13"W 225.59' ALONG A WESTERLY LINE OF SAID WILD HORSE RIDGE FIFTH ADDITION TO THE SOUTHWEST CORNER OF LOT 9 OF SAID WILD HORSE RIDGE FIFTH ADDITION, SAID POINT ALSO BEING ON THE NORTHEASTERLY LINE OF TRACT "A" OF WILD HORSE RIDGE FIRST ADDITION AS RECORDED IN INSTRUMENT NO. 2008-00021274 IN THE OFFICE OF THE RECORDER, BLACK HAWK COUNTY, IOWA; THENCE, N60°06'20"W 44.07' ALONG SAID NORTHEASTERLY LINE; THENCE, N43°50'08"W 149.78'; THENCE, N30°12'30"W 295.00'; THENCE, N48°53'51"W 75.07'; THENCE, N89°21'04"W 145.14'. THE AFORESAID ALL BEING ALONG SAID NORTHEASTERLY LINE OF TRACT "A"; THENCE, N0°39'15"E 220.00'; THENCE, S89°20'45"E 25.17'; THENCE, N0°07'18"E 140.00'; THENCE, S89°20'56"E 191.39'; THENCE, S68°37'20"E 65.82'; THENCE, S53°43'59"E 295.00'; THENCE, N36°16'01"E 258.05'; THENCE, S50°37'48"E 136.34'; THENCE, NORTHEASTERLY 12.95' ALONG THE ARC OF A 780.00' RADIUS CURVE, CONCAVE SOUTHEASTERLY, HAVING A CHORD BEARING OF N39°50'43"E AND A CHORD DISTANCE OF 12.95'; THENCE, S49°40'44"E 212.64' TO THE POINT OF BEGINNING, CONTAINING 9.36 ACRES INCLUDING 1.99 ACRES OF ROAD RIGHT OF WAY. SUBJECT TO EASEMENTS AND RESTRICTIONS OF RECORD, IF ANY.

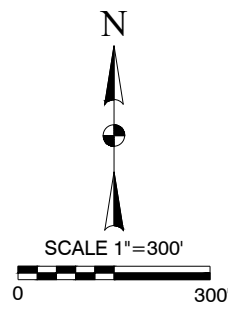

CGA

Clapsaddle-Garber Associates, Inc
16 East Main Street
Marshalltown, Iowa 50158
Ph 641-752-6701
www.cgaconsultants.com

DRAWN CAQ	SHEET NO. 2 OF 4
DATE 7-5-2022	PROJECT NO. 5805.05

FINAL PLAT WILD HORSE RIDGE SIXTH ADDITION CEDAR FALLS, IOWA

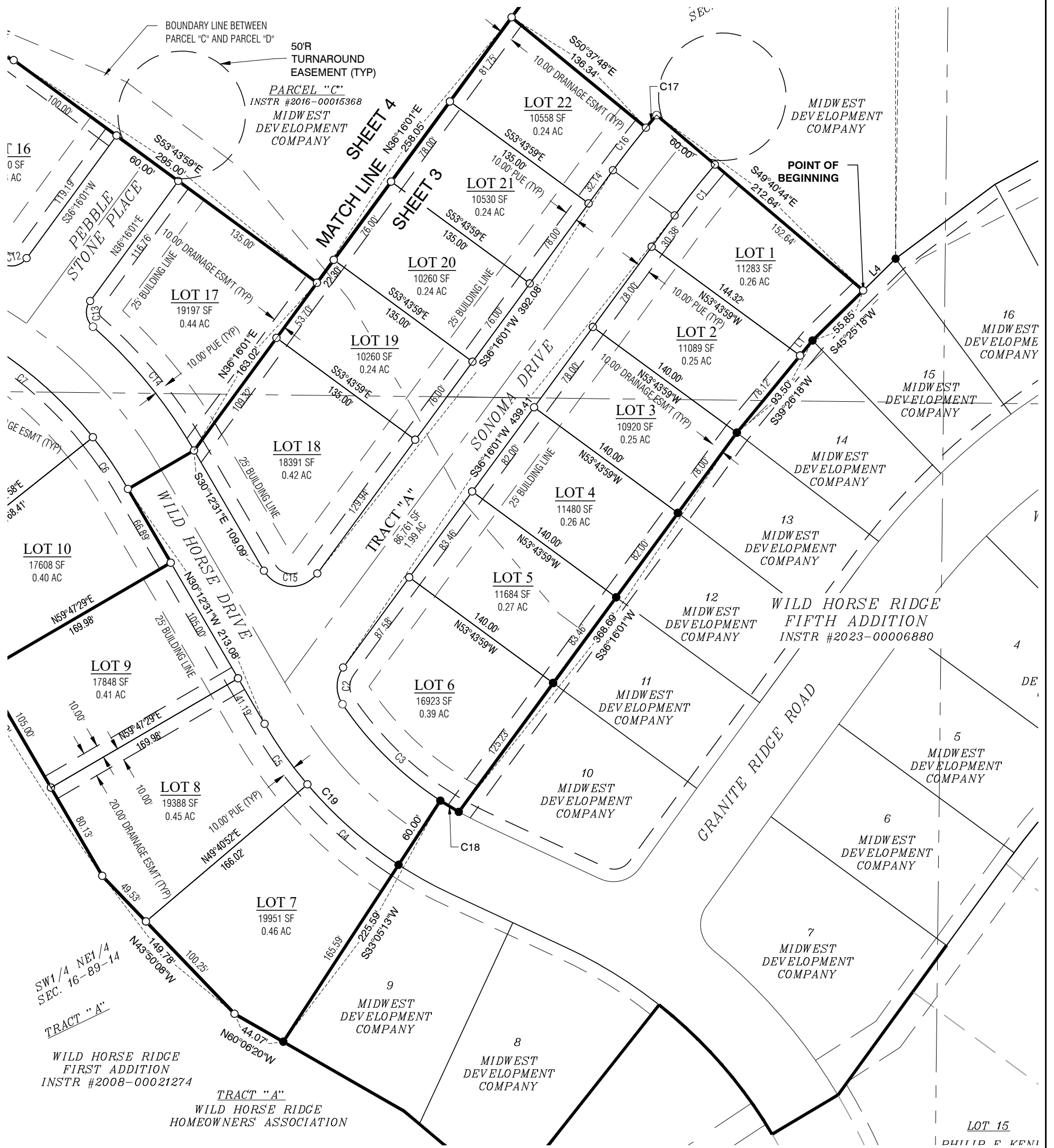

Curve Table

CURVE DATA	ARC LENGTH	RADIUS	DELTA ANGLE	CHORD BEARING	CHORD
C1	50.95'	720.00'	4°03'15"	S38°17'38"W	50.94'
C2	30.61'	25.00'	70°09'44"	S1°11'09"W	28.74'
C3	125.41'	270.00'	26°36'50"	S47°12'08"E	124.29'
C4	95.58'	330.00'	16°35'39"	S48°36'58"E	95.24'
C5	58.23'	330.00'	10°06'37"	S35°15'50"E	58.16'
C6	48.99'	321.82'	8°43'17"	N34°04'52"W	48.94'
C7	144.60'	320.00'	25°53'27"	N51°23'45"W	143.37'
C8	139.65'	320.00'	25°00'17"	N76°50'37"W	138.55'
C9	17.64'	380.00'	2°39'34"	N88°00'59"W	17.64'
C10	74.24'	380.00'	11°11'38"	N81°05'23"W	74.12'
C11	90.63'	380.00'	13°39'55"	N68°39'36"W	90.42'
C12	21.44'	15.00'	81°54'21"	N77°13'11"E	19.66'
C13	22.25'	15.00'	85°00'23"	S6°14'11"E	20.27'
C14	125.86'	380.40'	18°57'23"	N39°15'23"W	125.28'

Curve Table

CURVE DATA	ARC LENGTH	RADIUS	DELTA ANGLE	CHORD BEARING	CHORD
C15	49.53'	25.00'	113°31'28"	S86°58'15"E	41.82'
C16	42.25'	780.00'	3°06'12"	S37°49'06"W	42.24'
C17	12.95'	780.00'	0°57'05"	N39°50'43"E	12.95'
C18	16.95'	270.00'	3°35'46"	N58°42'40"W	16.94'
C19	153.81'	330.00'	26°42'16"	S43°33'39"E	152.42'
C20	333.24'	320.05'	59°39'25"	N59°30'54"W	318.39'
C21	182.51'	380.00'	27°31'07"	N75°35'12"W	180.76'

LINE DATA

LINE NUMBER	BEARING	DISTANCE
L1	S39°26'18"W	15.38'
L2	S89°20'45"E	4.02'
L3	S89°20'45"E	25.17'
L4	S45°25'18"W	35.57'



SCALE 1"=80'



Clapsaddle-Garber Associates, Inc
16 East Main Street
Marshalltown, Iowa 50158
Ph 641-752-6701
www.cgaconsultants.com

DRAWN CAQ	SHEET NO. 3 OF 4
DATE 7-5-2022	PROJECT NO. 5805.05

FINAL PLAT WILD HORSE RIDGE SIXTH ADDITION CEDAR FALLS, IOWA

NW1/4 NE1/4
SEC. 16-89-14
PARCEL "C"
INSTR #2016-00015368
MIDWEST
DEVELOPMENT
COMPANY

PARCEL "D"
INSTR #2016-00015368
MIDWEST
DEVELOPMENT
COMPANY

PARCEL "C"
INSTR #2016-00015368
MIDWEST
DEVELOPMENT
COMPANY

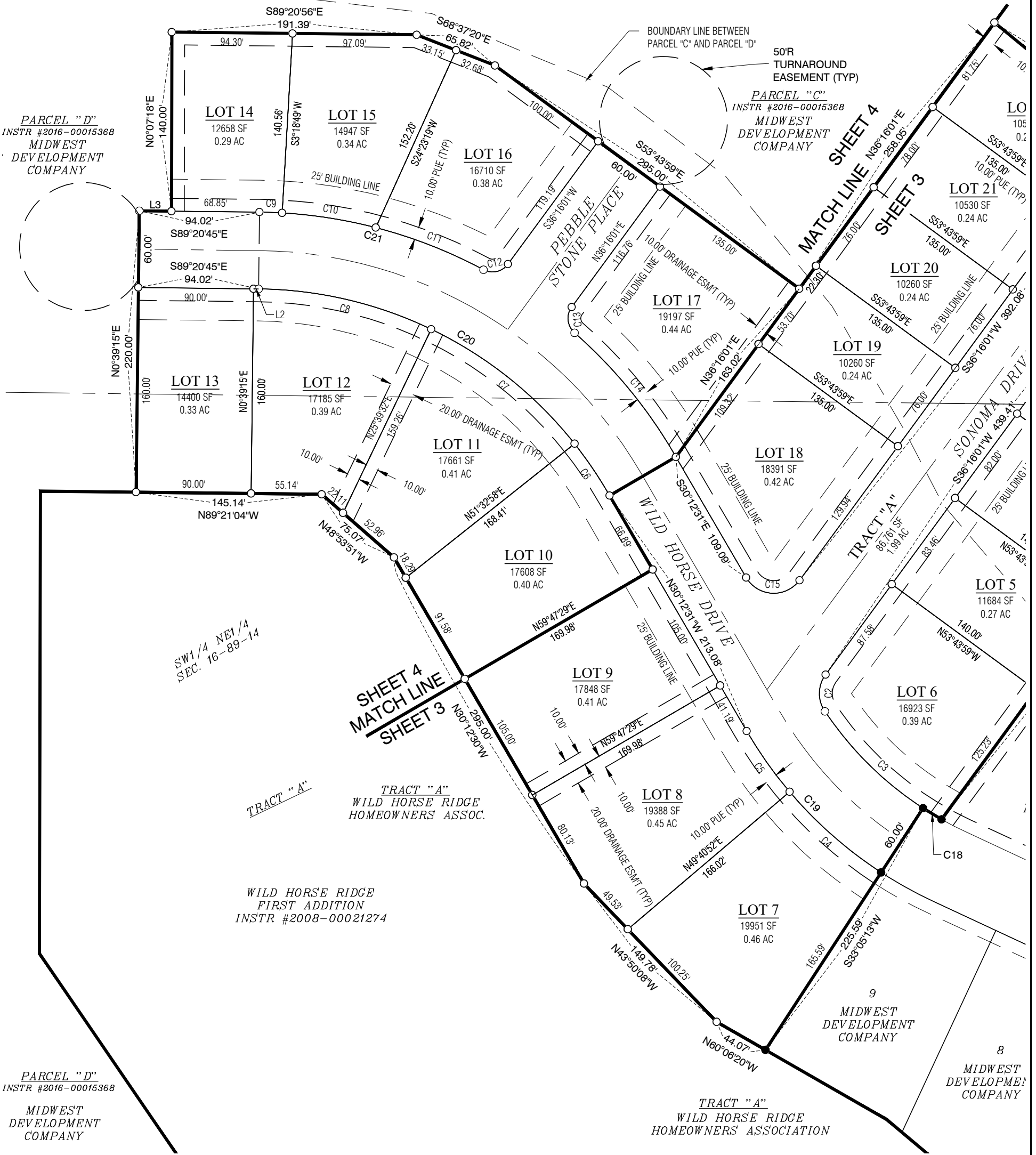

SW1/4 NE1/4
SEC. 16-89-14

TRACT "A"
WILD HORSE RIDGE
HOMEOWNERS ASSOC.

WILD HORSE RIDGE
FIRST ADDITION
INSTR #2008-00021274

PARCEL "D"
INSTR #2016-00015368
MIDWEST
DEVELOPMENT
COMPANY

TRACT "A"
WILD HORSE RIDGE
HOMEOWNERS ASSOCIATION

Clapsaddle-Garber Associates, Inc
16 East Main Street
Marshalltown, Iowa 50158
Ph 641-752-6701
www.cgaconsultants.com

DRAWN CAQ	SHEET NO. 4 OF 4
DATE 7-5-2022	PROJECT NO. 5805.05

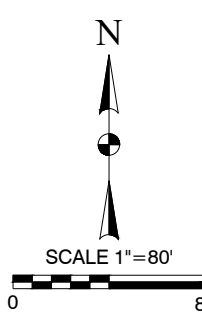

SURETY BOND NO. IAC593699

MAINTENANCE BOND

KNOW ALL BY THESE PRESENTS:

That we, Midwest Development Company, as Principal (hereinafter the "Principal") and Merchants Bonding Company (Mutual), as Surety are held and firmly bound unto the City of Cedar Falls, Iowa, as Obligee (hereinafter referred to as "the City"), and to all persons who may be injured by any breach of any of the conditions of this Bond in the amount of one million three hundred fifty-seven thousand nine hundred ten dollars (\$1,357,910.00), lawful money of the United States, for the payment of which sum, well and truly to be made, we bind ourselves, our heirs, legal representatives and assigns, jointly or severally, firmly by these presents.

Whereas, prior to City Council approval of a final plat of a subdivided area, the Principal shall submit to the City engineer this maintenance bond to provide for the protection of the City against future liability for any and all defects in workmanship or materials and any conditions that could result in structural or other failure of all of the public infrastructure improvements required as part of final plat approval for a period of three (3) years from the date of acceptance of any required public improvement which is the 5th day of January, 2023; and

Whereas, the Principal represents that it has constructed and installed all required public infrastructure improvements as required as part of the final plat approval, to conform with approved construction plans which meet the design standards and technical standards established for such public improvements by the City and by Cedar Falls Utilities, and as shown on the approved construction plans and described in detail as follows:

Wildhorse Ridge Sixth Addition Subdivision maintenance

Now therefore, it is expressly understood and agreed by the Principal and Surety in this bond that the following provisions are a part of this Bond and are binding upon said Principal and Surety, to-wit:

- 1. MAINTENANCE: The Principal and Surety on this Bond hereby agree, at their own expense:
 - A. To remedy any and all defects that may develop in or result from work performed on the above described public infrastructure improvements required as part of final plat approval for a period of three (3) years from the date of acceptance of all required public infrastructure improvements, by reason of defects in workmanship or materials used in construction of said work;
 - B. To keep all work in continuous good repair; and
 - C. To pay the City's reasonable costs of monitoring and inspection to assure that any defects are remedied, and to repay the City all outlay and expense incurred as a result of Principal's and Surety's failure to remedy any defect as required by this section.
 - D. Following Principal and Surety's repair and construction of any failed infrastructure component or elements the city engineer shall determine whether the three-year bond shall be renewed or extended beyond the original three-year bond period. In the event of major structural failures the maintenance bond shall be renewed if recommended by the city engineer for a new three-year period from the date of repair for that portion of the public

improvements involved in the structural failure and repair

2. GENERAL: Every Surety on this Bond shall be deemed and held bound, any contract to the contrary notwithstanding, to the following provisions:
- A. That this Bond shall remain in full force and effect until the maintenance period is completed, whether completed within the specified three (3) year period or within an extension thereof, as provided in Section I-D.
 - B. That no provision of this Bond or of any other contract shall be valid that limits to less than five years after the date of acceptance the right to sue on this Bond.
 - C. That as used herein, the phrase "all outlay and expense" is not to be limited in any way, but shall include the actual and reasonable costs and expenses incurred by the City including interest, benefits, and overhead where applicable. Accordingly, "all outlay and expense" would include but not be limited to all contract or employee expense, all equipment usage or rental, materials, testing, outside experts, attorney's fees (including overhead expenses of the City's staff attorneys), and all costs and expenses of litigation as they are incurred by the City. It is intended the Principal and Surety will defend and indemnify the City on all claims made against the City on account of Principal's failure to perform as required in this bond, that all agreements and promises set forth in this Bond will be fulfilled, and that the City will be fully indemnified so that it will be put into the position it would have been in had the infrastructure improvements been constructed in the first instance as required.
 - D. In the event the City incurs any "outlay and expense" in defending itself against any claim as to which the Principal or Surety should have provided the defense, or in the enforcement of the promises given by the Principal in the approved construction plans, or in the enforcement of the promises given by the Principal and Surety in this Bond, the Principal and Surety agree that they will make the City whole for all such outlay and expense, provided that the Surety's obligation under this bond shall not exceed 125% of the penal sum of this bond.

In the event that any actions or proceedings are initiated regarding this Bond, the parties agree that the venue thereof shall be the United States District Court for the Northern District of Iowa or the Iowa District Court for Black Hawk County, State of Iowa. If legal action is required by the City to enforce the provisions of this Bond or to collect the monetary obligation incurring to the benefit of the City, the Principal and the Surety agree, jointly, and severally, to pay the City all outlay and expense incurred therefor by the City. All rights, powers, and remedies of the City hereunder shall be cumulative and not alternative and shall be in addition to all rights, powers, and remedies given to the City, by law. The City may proceed against surety for any amount guaranteed hereunder whether action is brought against the Principal or whether Principal is joined in any such action(s) or not.

NOW THEREFORE, the condition of this obligation is such that if said Principal shall faithfully perform all the promises of the Principal, as set forth and provided in the approved construction plans and in this Bond, then this obligation shall be null and void, otherwise it shall remain in full force and effect.

When a work, term, or phrase is used in this Bond, it shall be interpreted or construed first as defined in this Bond and the approved construction plans; second, if not defined in the Bond and the approved construction plans, it shall be interpreted or construed as defined in applicable provisions of the Iowa Code; third, if not defined in the Iowa Code, it shall be interpreted or construed according to its generally accepted meaning in the construction industry; and fourth, if it has no generally accepted meaning in the construction industry, it

shall be interpreted or construed according to its common or customary usage.

Failure to specify or particularize shall not exclude terms or provisions not mentioned and shall not limit liability hereunder. The approved construction plans are hereby made a part of this bond.

Witness our hands, in triplicate, this 4th day of January, 2023.

Countersigned By:

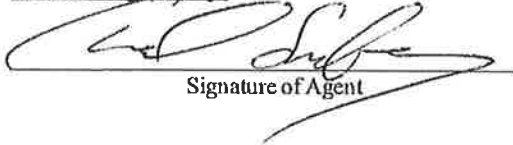
Signature of Agent

Chad Smeby
Printed Name of Agent

Skogman Insurance
Company Name

1110 Dina CT STE B
Company Address

Hiawatha, IA 52233
City, State, Zip Code

319-366-6288
Company Telephone Number

PRINCIPAL:

Midwest Development Company
Principal

By: 
Signature

Hunter Skogman President Land Acquisition ar
Title

SURETY:

Merchants Bonding Company (Mutual)
Surety Company

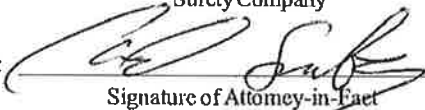
By: 
Signature of Attorney-in-Fact

Chad Smeby
Printed Name of Attorney-in-Fact

Merchants Bonding Company (Mutual)
Company Name

P.O. Box 14498
Company Address

Des Moines IA 50306-3498
City, State, Zip Code

(800) 678-8171
Company Telephone Number

NOTE:

MERCHANTS BONDING COMPANY™

POWER OF ATTORNEY

Know All Persons By These Presents, that MERCHANTS BONDING COMPANY (MUTUAL) and MERCHANTS NATIONAL BONDING, INC., both being corporations of the State of Iowa, d/b/a Merchants National Indemnity Company (in California only) (herein collectively called the "Companies") do hereby make, constitute and appoint, individually,

Chad Smeby

their true and lawful Attorney(s)-in-Fact, to sign its name as surety(ies) and to execute, seal and acknowledge any and all bonds, undertakings, contracts and other written instruments in the nature thereof, on behalf of the Companies in their business of guaranteeing the fidelity of persons, guaranteeing the performance of contracts and executing or guaranteeing bonds and undertakings required or permitted in any actions or proceedings allowed by law.

This Power-of-Attorney is granted and is signed and sealed by facsimile under and by authority of the following By-Laws adopted by the Board of Directors of Merchants Bonding Company (Mutual) on April 23, 2011 and amended August 14, 2015 and adopted by the Board of Directors of Merchants National Bonding, Inc., on October 16, 2015.

"The President, Secretary, Treasurer, or any Assistant Treasurer or any Assistant Secretary or any Vice President shall have power and authority to appoint Attorneys-in-Fact, and to authorize them to execute on behalf of the Company, and attach the seal of the Company thereto, bonds and undertakings, recognizances, contracts of indemnity and other writings obligatory in the nature thereof."

"The signature of any authorized officer and the seal of the Company may be affixed by facsimile or electronic transmission to any Power of Attorney or Certification thereof authorizing the execution and delivery of any bond, undertaking, recognizance, or other suretyship obligations of the Company, and such signature and seal when so used shall have the same force and effect as though manually fixed."

In connection with obligations in favor of the Florida Department of Transportation only, it is agreed that the power and authority hereby given to the Attorney-in-Fact includes any and all consents for the release of retained percentages and/or final estimates on engineering and construction contracts required by the State of Florida Department of Transportation. It is fully understood that consenting to the State of Florida Department of Transportation making payment of the final estimate to the Contractor and/or its assignee, shall not relieve this surety company of any of its obligations under its bond.

In connection with obligations in favor of the Kentucky Department of Highways only, it is agreed that the power and authority hereby given to the Attorney-in-Fact cannot be modified or revoked unless prior written personal notice of such intent has been given to the Commissioner-Department of Highways of the Commonwealth of Kentucky at least thirty (30) days prior to the modification or revocation.

In Witness Whereof, the Companies have caused this instrument to be signed and sealed this 4th day of January, 2023.



MERCHANTS BONDING COMPANY (MUTUAL)
MERCHANTS NATIONAL BONDING, INC.
d/b/a MERCHANTS NATIONAL INDEMNITY COMPANY

By *Larry Taylor*
President

STATE OF IOWA
COUNTY OF DALLAS ss.

On this 4th day of January, 2023, before me appeared Larry Taylor, to me personally known, who being by me duly sworn did say that he is President of MERCHANTS BONDING COMPANY (MUTUAL) and MERCHANTS NATIONAL BONDING, INC.; and that the seals affixed to the foregoing instrument are the Corporate Seals of the Companies; and that the said instrument was signed and sealed in behalf of the Companies by authority of their respective Boards of Directors.



Kim Lee
Notary Public

(Expiration of notary's commission does not invalidate this instrument)

I, William Warner, Jr., Secretary of MERCHANTS BONDING COMPANY (MUTUAL) and MERCHANTS NATIONAL BONDING, INC., do hereby certify that the above and foregoing is a true and correct copy of the POWER-OF-ATTORNEY executed by said Companies, which is still in full force and effect and has not been amended or revoked.

In Witness Whereof, I have hereunto set my hand and affixed the seal of the Companies on this 4th day of January, 2023.



William Warner Jr.
Secretary

FINAL LIEN WAIVER
RELEASE BY CLAIMANTS

The undersigned, having received payment in full for all labor,
Materials, supplies, or equipment supplied to:

Owen Contracting, Inc.

Contractor

Or to any subcontractor/supplier, in the construction or repair of the
Improvements upon the property located at:

Wild Horse Ridge 6th Addition

And furnished in the execution and fulfillment of contract between
Said Contractor and

~~Benton's Ready Mix~~

Subcontractor/Supplier

Dated: 10-31-22

Do (does) hereby release and waiver any and all claims, lien and liens
Right, of any kind, nature, or description what so ever, against said
Property and the owner thereof:



Lienor or Claimant

10-31-22

Date Signed

FINAL LIEN WAIVER
RELEASE BY CLAIMANTS

The undersigned, having received payment in full for all labor,
Materials, supplies, or equipment supplied to:

Owen Contracting, Inc.

Contractor

Or to any subcontractor/supplier, in the construction or repair of the
Improvements upon the property located at:

Wild Horse Ridge 6th Addition

And furnished in the execution and fulfillment of contract between
Said Contractor and

Logan Contractors Supply

Subcontractor/Supplier

Dated: November 3, 2022

Do (does) hereby release and waiver any and all claims, lien and liens
Right, of any kind, nature, or description what so ever, against said
Property and the owner thereof:

Julie Kroll

Julie Kroll, CFO

Lienor or Claimant

November 3, 2022

Date Signed

Invoice #A6836

WAIVER OF LIEN

STATE OF IOWA
COUNTY OF LINN

TO WHOM IT MAY CONCERN:

WHEREAS, the undersigned, **BENTON'S READY MIXED CONCRETE** has been employed by **Rathje Construction Co.** to furnish material and labor for the **Midwest Development – Wild Horse Ridge 6th Addition**

The undersigned, for and in consideration of **Thirteen Thousand Five Hundred Fifty-Four Dollars & 78/100 (\$13,554.78)**

Payment of Invoices: 198225, 198305, 198534, 198591, 198649, 198708, 198765, 198884, 198951, 199027, 199116, 199155, 199213, 201616 & 201719.

and other good and valuable consideration, the receipt whereof is hereby acknowledged, do hereby waive and release any and all lien or claim of, or right to lien under the Statutes of Iowa relating to mechanics' liens on the above-described premises, and the improvements thereon, and on the monies or other considerations due or to become due from the owner, on account of labor, services, material, fixtures, apparatus or machinery heretofore furnished to this date by the undersigned for the above-described premises.

Dated this 29 day of December, 2022.



(Signature of sole owner or authorized representative of corporation or partnership)

SUBCONTRACTOR'S AFFIDAVIT OR CONTRACTOR'S SWORN STATEMENT MUST BE DATED & SIGNED.

JSS (12/27/22)

WAIVER OF LIEN

STATE OF IOWA
COUNTY OF LINN

TO WHOM IT MAY CONCERN:

WHEREAS, the undersigned, BMC AGGREGATES L.C.

has been employed by Rathje Construction Co. to furnish material and labor for the
Midwest Development – Wild Horse Ridge 6th Addition

The undersigned, for and in consideration of

One Hundred Twenty-Four Thousand Six Hundred Thirty-Six Dollars & 70/100
(\$124, 636.70)

Payment of Invoices: 122042, 122209, 122393, 122506, 128462, 129458, 130156, 131056, 132392,
133370, 133371, 133946, 134633, 134634, 135465, 136135, 136739 & 138080.

and other good and valuable consideration, the receipt whereof is hereby acknowledged,
do hereby waive and release any and all lien or claim of, or right to lien under the Statutes of
Iowa relating to mechanics' liens on the above-described premises, and the improvements
thereon, and on the monies or other considerations due or to become due from the owner, on
account of labor, services, material, fixtures, apparatus or machinery heretofore furnished to this
date by the undersigned for the above-described premises.

Dated this 29th day of December, 2022.

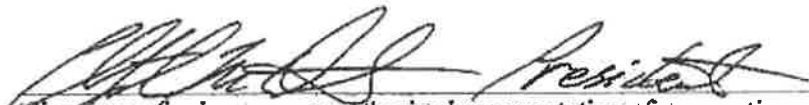
(Signature of sole owner or authorized representative of corporation or partnership)

SUBCONTRACTOR'S AFFIDAVIT OR CONTRACTOR'S SWORN STATEMENT MUST BE
DATED & SIGNED.

JSS (12/27/22)

WAIVER OF LIEN

STATE OF IOWA
COUNTY OF LINN

TO WHOM IT MAY CONCERN:

WHEREAS, the undersigned, **SCHIMBERG COMPANY**
has been employed by **Rafije Construction Co.** to furnish material and labor for the
Midwest Development - Wild Horse Ridge 6th Addition

The undersigned, for and in consideration of

Fifteen Thousand Two Hundred Three Dollars & 41/100
(\$15,203.41)

Payment of Invoices: 813654301, 815262400, 1508600, 819300900, 2074900, 2073900, 819568500, 819568000, 819624600, 2204100, 906821500, 819698000, 819703300, 819707700, 819713300, 819688500, 2177600, 819874100, 2189200, 2190700, 820077100, 906822500, 906823000, 819306600, 820206800, 906828600, 2728700, 906760100, 2763200 & 919707700.

and other good and valuable consideration, the receipt whereof is hereby acknowledged,
do hereby waive and release any and all lien or claim of, or right to lien under the Statutes of
Iowa relating to mechanics' liens on the above-described premises, and the improvements
thereon, and on the monies or other considerations due or to become due from the owner, on
account of labor, services, material, fixtures, apparatus or machinery heretofore furnished to this
date by the undersigned for the above-described premises.

Dated this _____ day of _____, 2022.

(Signature of sole owner or authorized representative of corporation or partnership)

SUBCONTRACTOR'S AFFIDAVIT OR CONTRACTOR'S SWORN STATEMENT MUST BE
DATED & SIGNED.

JSS (12/27/22)

WAIVER OF LIEN

STATE OF IOWA
COUNTY OF LINN

TO WHOM IT MAY CONCERN:

WHEREAS, the undersigned, **WIESER PRECAST, INC.**

has been employed by **Rathje Construction Co.** to furnish material and labor for the
Midwest Development – Wild Horse Ridge 6th Addition

The undersigned, for and in consideration of

**Forty-Two Thousand Eight Hundred Thirty-Six Dollars & 50/100
(\$42,836.50)**

Payment of Invoices: 49933, 49934, 49935, 49936, 49972 & 50252.

and other good and valuable consideration, the receipt whereof is hereby acknowledged,
do hereby waive and release any and all lien or claim of, or right to lien under the Statutes of
Iowa relating to mechanics' liens on the above-described premises, and the improvements
thereon, and on the monies or other considerations due or to become due from the owner, on
account of labor, services, material, fixtures, apparatus or machinery heretofore furnished to this
date by the undersigned for the above-described premises.

Dated this 30th day of December, 2022.

Wieser Precast Inc - Cynthia M Maxwell
(Signature of sole owner or authorized representative of corporation or partnership)

SUBCONTRACTOR'S AFFIDAVIT OR CONTRACTOR'S SWORN STATEMENT MUST BE
DATED & SIGNED.

JSS (12/27/22)

WAIVER OF LIEN

STATE OF IOWA
COUNTY OF LINN

TO WHOM IT MAY CONCERN:

WHEREAS, the undersigned, **SOIL CONCEPTS, INC.**

has been employed by **Rathje Construction Co.** to furnish material and labor for the

Midwest Development – Wild Horse Ridge 6th Addition

The undersigned, for and in consideration of

Seventeen Thousand Six Hundred Eighty-Eight Dollars & 35/100
(\$17,688.35)

Payment of Invoices: 7288/FEB, 7288/FEB, 7288/FEB, 7288/JUN & 7288/AUG.

and other good and valuable consideration, the receipt whereof is hereby acknowledged,
do hereby waive and release any and all lien or claim of, or right to lien under the Statutes of
Iowa relating to mechanics' liens on the above-described premises, and the improvements
thereon, and on the monies or other considerations due or to become due from the owner, on
account of labor, services, material, fixtures, apparatus or machinery heretofore furnished to this
date by the undersigned for the above-described premises.

Dated this 31 day of Dec, 2022.

(Signature of sole owner or authorized representative of corporation or partnership)

SUBCONTRACTOR'S AFFIDAVIT OR CONTRACTOR'S SWORN STATEMENT MUST BE
DATED & SIGNED.

JSS (12/27/22)

Final Lien Waiver
Release By Claimants

The undersigned, having received payment in full for all labor, Materials, supplies, or equipment supplied to:

MIDWEST DEVELOPMENT COMPANY

Or to any subcontractor, in the construction or repair of the Improvements upon the property located at:

WILDHORSE 6th ADDITION, IN THE CITY OF CEDAR FALLS, IOWA

And furnished in the execution and fulfillment of contract between Said contractor and

Owen Contracting, Inc.

Contractor/Supplier

Dated: 10/31/2022

Do (does) hereby release and waiver any and all claims, lien and liens right, of any kind, nature, or description what so ever, against said property and the owner thereof:



Lienor or Claimant

Date Signed: 11/01/22



DEPARTMENT OF PUBLIC WORKS

City of Cedar Falls
 220 Clay Street
 Cedar Falls, Iowa 50613
 Phone: 319-268-5161
 Fax: 319-268-5197
www.cedarfalls.com

MEMORANDUM
Engineering Division

TO: Honorable Mayor Robert M. Green and City Council

FROM: Luke Andreasen, PE

DATE: January 5, 2023

SUBJECT: Main Street Reconstruction (6th St. to University)
 City Project Number: RC-000-3283
 Warranty Deed

The City of Cedar Falls is planning to reconstruct Main Street from 6th Street to University Avenue from a 4-lane roadway to a 3-lane roadway. Included in the project will be the intersections at Seerley Boulevard, 18th Street, 12th Street, and potentially 6th Street which will be replaced with single-lane roundabouts to improve the overall traffic safety and flow in all directions of travel. The project will also include improvements to the water main, sanitary sewer, storm sewer, sidewalks, and other miscellaneous roadway items. The project required partial acquisition for new city ROW from nine (9) properties. In addition, two (2) total take acquisitions were required to accommodate the new roundabout at the 12th/Main intersection. The City has closed on the following acquisition:

Parcel #	Owner	Address/Parcel ID	Acquisition Type
124	St. Patrick's Church	705 Main Street	Partial

Attached is a strip map of the entire project where these properties can be identified by parcel number.

The Engineering Division of the Public Works Department recommends that the City Council state their support in the form of a resolution approving the warranty deed for this property acquisition.

If you have any questions or need additional information, please feel free to contact me.

xc: Chase Schrage, Director of Public Works
 David Wicke, City Engineer



**Main Street Reconstruction
Cedar Falls, Iowa**





**WARRANTY DEED
(CORPORATE GRANTOR)
Recorder's Cover Sheet**

Preparer Information: Kevin Rogers, 220 Clay Street, Cedar Falls, IA 50613, Phone: (319) 273-8600

Taxpayer Information: City Clerk, City of Cedar Falls, 220 Clay Street, Cedar Falls, IA 50613

Return Document To: City Clerk, City of Cedar Falls, 220 Clay Street, Cedar Falls, IA 50613

Grantors: St. Patrick's Church

Grantees: City of Cedar Falls, Iowa

Legal Description: See Page 2

Document or instrument number of previously recorded documents:



**WARRANTY DEED
(CORPORATE GRANTOR)**

For the consideration of One Dollar(s) and other valuable consideration, St. Patrick's Church, a religious corporation organized and existing under the laws of Iowa, does hereby Convey to City of Cedar Falls, Iowa, a municipal corporation organized and existing under the laws of Iowa, the following described real estate in Black Hawk County, Iowa:

See Legal Description and Acquisition Plat attached.

There is no known private burial site, well, solid waste disposal site, underground storage tank, hazardous waste, or private sewage disposal system on the property as described in Iowa Code Section 558.69, and therefore the transaction is exempt from the requirement to submit a groundwater hazard statement.

The corporation hereby covenants with grantees, and successors in interest, that it holds the real estate by title in fee simple; that it has good and lawful authority to sell and convey the real estate; that the real estate is free and clear of all liens and encumbrances, except as may be above stated; and it covenants to Warrant and Defend the real estate against the lawful claims of all persons, except as may be above stated.

Words and phrases herein, including acknowledgment hereof, shall be construed as in the singular or plural number, according to the context.

Dated: 12/29/2022

St. Patrick's Church

By Regena Huffman
Its Business Admin.

STATE OF IOWA, COUNTY OF BLACK HAWK

This record was acknowledged before me on 12/29/2022,
by Regena Huffman as Business Admin of St. Patrick's
Church, a religious corporation.

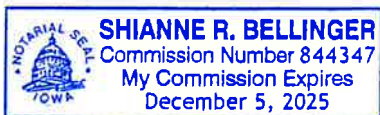

Shianne R. Bellinger
Signature of Notary Public

Legal Description

A PARCEL OF LAND LOCATED IN LOT 9 OF AUDITOR'S PLAT NO. 16, AN OFFICIAL PLAT, AS RECORDED IN BOOK E, PAGE 146 OF THE BLACK HAWK COUNTY RECORDER'S OFFICE, CITY OF CEDAR FALLS, BLACK HAWK COUNTY, IOWA, MORE PARTICULARLY DESCRIBED AS FOLLOWS:

COMMENCING AT THE SOUTHWEST CORNER OF LOT 7 BLOCK 5 OF GARRISON & DEAN'S ADDITION, AN OFFICIAL PLAT, THENCE SOUTH 00° 34' 29" EAST, 40.00 FEET TO THE NORTHWEST CORNER OF LOT 9 OF AUDITOR'S PLAT NO. 16, ALSO BEING THE POINT OF BEGINNING; THENCE NORTH 89° 09' 00" EAST, 17.56 FEET ALONG THE SOUTH RIGHT-OF-WAY LINE OF E 8TH STREET; THENCE SOUTH 67° 45' 09" WEST, 18.89 FEET TO THE EAST RIGHT-OF-WAY LINE OF MAIN STREET; THENCE NORTH 00° 37' 10" WEST, 6.89 FEET ALONG SAID EAST RIGHT-OF-WAY LINE TO THE POINT OF BEGINNING.

FOR THE PURPOSE OF THIS DESCRIPTION, ALL BEARING AND DISTANCES ARE REFERENCED TO NAD83(2011) IA SPCS NORTH ZONE, US SURVEY FOOT.

Index Legend	
Location:	Lot 9, Auditor's Plat No. 16
Requestor:	City of Cedar Falls
Proprietor:	St. Patrick's Church
Surveyor:	Wesley Shimp
Surveyor Company:	Foth Infrastructure & Environment, LLC
Return To:	411 6th Avenue SE, Suite 400 Cedar Rapids, IA 52401 (319) 365-9565

Item 21.

ACQUISITION PLAT

EXHIBIT 124-F

RIGHT-OF-WAY BEING CONVEYED TO THE CITY OF CEDAR FALLS
MAIN STREET RECONSTRUCTION
800 & 802 MAIN STREET
PARCEL 124

PROPERTY OWNER:

ST. PATRICK'S CHURCH
705 MAIN STREET
CEDAR FALLS, IA 50613
BOOK 667, PAGE 418

LEGAL DESCRIPTION:

A PARCEL OF LAND LOCATED IN LOT 9 OF AUDITOR'S PLAT NO. 16, AN OFFICIAL PLAT, AS RECORDED IN BOOK E, PAGE 146 OF THE BLACK HAWK COUNTY RECORDER'S OFFICE, CITY OF CEDAR FALLS, BLACK HAWK COUNTY, IOWA, MORE PARTICULARLY DESCRIBED AS FOLLOWS:

COMMENCING AT THE SOUTHWEST CORNER OF LOT 7, BLOCK 5 OF GARRISON & DEAN'S ADDITION, AN OFFICIAL PLAT, THENCE SOUTH 00° 34' 29" EAST, 40.00 FEET TO THE NORTHWEST CORNER OF LOT 9 OF AUDITOR'S PLAT NO. 16, ALSO BEING THE POINT OF BEGINNING; THENCE NORTH 89° 09' 00" EAST, 17.56 FEET ALONG THE SOUTH RIGHT-OF-WAY LINE OF E 8TH STREET; THENCE SOUTH 67° 45' 09" WEST, 18.89 FEET TO THE EAST RIGHT-OF-WAY LINE OF MAIN STREET; THENCE NORTH 00° 37' 10" WEST, 6.89 FEET ALONG SAID EAST RIGHT-OF-WAY LINE TO THE POINT OF BEGINNING.

SAID TRACT CONTAINS 61 SQUARE FEET OR 0.001 ACRES MORE OR LESS, SUBJECT TO EASEMENTS AND RESTRICTIONS OF RECORD.

FOR THE PURPOSE OF THIS DESCRIPTION, ALL BEARING AND DISTANCES ARE REFERENCED TO NAD83(2011) IA SPCS NORTH ZONE, US SURVEY FOOT.

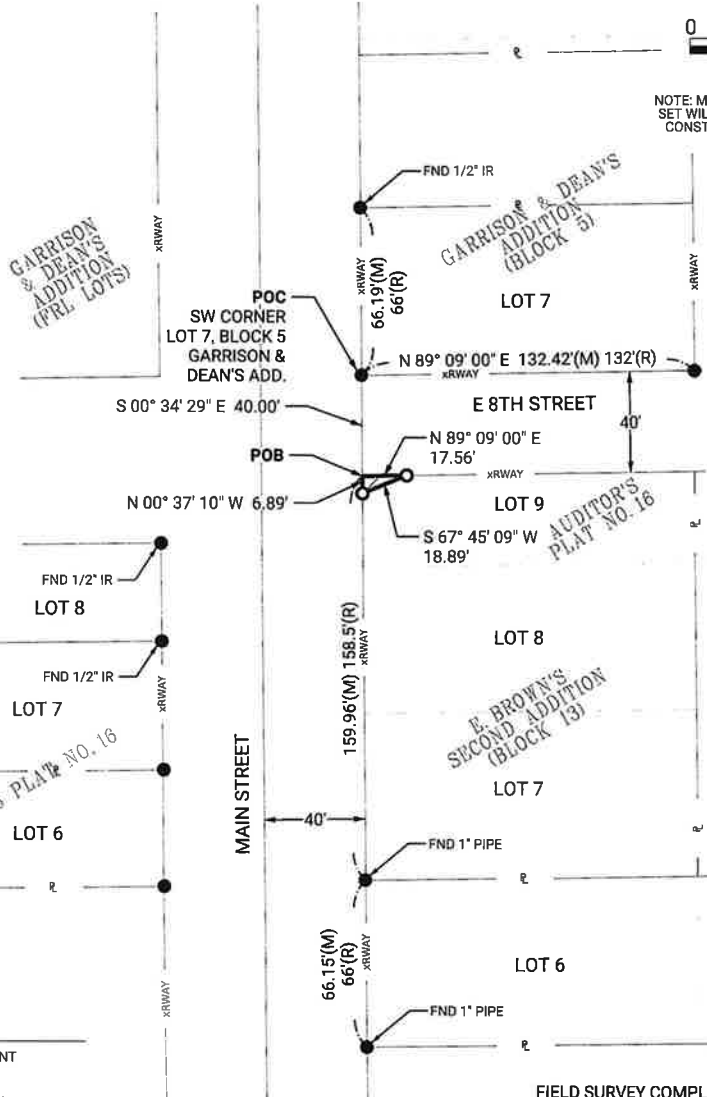

0 60
FEET

NOTE: MONUMENTS SHOWN TO BE SET WILL BE ESTABLISHED AFTER CONSTRUCTION IS COMPLETED

LEGEND

- ▲ FOUND SECTION CORNER MONUMENT
- △ SET SECTION CORNER MONUMENT
- FOUND PINCH PIPE (UNLESS NOTED)
- SET 1/2" REROD W/ORANGE CAP #24243 (UNLESS NOTED)
- (M) MEASURED DIMENSION
- (R) RECORDED DIMENSION
- I.R. IRON ROD
- I.P. IRON PIPE
- SECTION LINE
- XRWAY- RIGHT-OF-WAY LINE
- - - EXISTING LOT LINE
- - - PROPERTY LINE
- ▨ PROPOSED RIGHT-OF-WAY ACQUISITION

FIELD SURVEY COMPLETED: FEBRUARY 2022

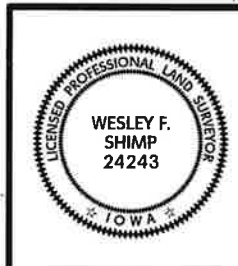

I hereby certify that this land surveying document was prepared and the related survey work was performed by me or under my direct personal supervision and that I am a duly licensed Professional Land Surveyor under the laws of the State of Iowa.

Wesley Shimp 8/11/2022
DATE
WESLEY F. SHIMP, P.L.S.
License Number: 24243
My license renewal date is DECEMBER 31, 2022
Pages or sheets covered by this seal:

1 of 1

SURVEY FOR:
CITY OF CEDAR FALLS
220 CLAY STREET
CEDAR FALLS, IA 50613
PHONE: (319) 273-8600

FOTH PROJECT NO. 21C017-02 DATE: 8/11/2022



Foth Infrastructure & Environment, LLC
411 6th Avenue SE, Suite 400 • Cedar Rapids, IA 52401-1931
Phone: 319-365-9565

209



DEPARTMENT OF PUBLIC WORKS

City of Cedar Falls
 220 Clay Street
 Cedar Falls, Iowa 50613
 Phone: 319-268-5161
 Fax: 319-268-5197
www.cedarfalls.com

MEMORANDUM *Engineering Division*

TO: Honorable Mayor Robert M. Green and City Council

FROM: Luke Andreasen, PE

DATE: January 6, 2023

SUBJECT: Various Intersection Improvements
 City Project Number: TS-000-3294
 Request for PS&E Approval

Submitted within for City Council approval are the Plans, Specifications, and Estimate of Costs and Quantities for the Various intersection improvements.

We recommend setting Monday, February 6, 2023 at 7:00 p.m. as the date and time for the public hearing on this project. This project is under the direction of the City of Cedar Falls.

This project consists of improvements at three city intersections. A new traffic signal at Hudson/Ridgeway, and landscaping improvements in the roundabout intersections at Prairie Parkway/Prairie View Road and Prairie Parkway/Brandilynn Boulevard.

The total estimated cost for the construction of this project is \$724,625.00. There is a \$40,000 private contribution for the roundabout landscaping in this project. The remaining funds will be provided by General Obligation Bonds, Local Sales Tax, Street Construction Fund, and Tax increment Financing.

The electronic plans, specifications, and estimate are available upon request for your review at the City Clerk's Office. The Engineering Division of the Public Works Department recommends approving the plans, specifications, and estimate.

xc: David Wicke, P.E., City Engineer
 Chase Schrage, Director of Public Works

PROJECT SPECIFICATIONS FOR HUDSON ROAD & W RIDGEWAY AVENUE INTERSECTION IMPROVEMENTS

**Project TS-000-3294
Cedar Falls, Iowa**

ENGINEER'S CERTIFICATION	
	<p>I hereby certify that this engineering document was prepared by me or under my direct personal supervision and that I am a duly licensed professional engineer under the laws of the State of Iowa.</p> <p><i>Patrick D. Schwickerath</i> Date: <u>01/03/23</u> Patrick D. Schwickerath, P.E. Iowa License No. P18652 My license renewal date is December 31, 2023</p> <p>Pages or sheets covered by this seal: <u>1-34.</u></p>

TABLE OF CONTENTS

	<u>Page Number</u>
TITLE SHEET	1
TABLE OF CONTENTS	2-3
NOTICE OF PUBLIC HEARING	4
NOTICE TO BIDDERS	5-7
 DIVISION 1 – Instruction to Bidders	
00 Pre-Bid Meeting	8
01 Definition and Terms	8
02 Qualification of the Bidder	8-9
03 Contents of the Proposal Forms	9
04 Taxes	10
05 Submission of the Proposal, Identity of Bidder and Bid Security	10
Form of Proposal	11-13
Bid Bond	14
Bidder Status Form	15
Authorization to transact business	16
Non-Collusion Affidavit of Prime Bidder	17
Form of Contract	18-19
Performance, Payment and Maintenance Bond	20-23
Notice to Proceed	24
 DIVISION 2 – Special Provisions	
01 Award of Contract	25
02 Availability of Site	25
03 Protection of Line and Grade Stakes	25
04 Borrow and Waste Sites	26
05 Contract Time	26
06 Work Progress and Schedule	26
07 Weekly record of Calendar Days	26
08 Liquidated Damages	26
09 Progress Payments and Vouchers	27
10 Pollution Prevention Plan	27-28
11 Method of Measurement	29
12 Basis of Payment	29

DIVISION 3 – Standard Specifications

The City of Cedar Falls has adopted the 2022 Edition of the STATEWIDE URBAN STANDARD SPECIFICATIONS FOR PUBLIC IMPROVEMENTS (SUDAS) as the City’s Standard Specification.

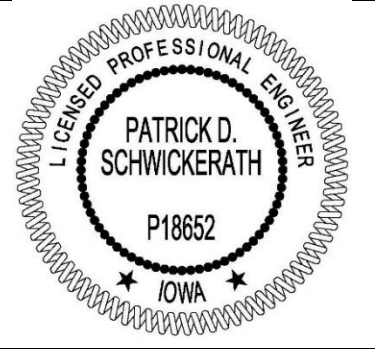
This Standard Specification is amended by the “City of Cedar Falls” Supplemental Specifications to the 2021 Edition of the SUDAS Statewide Urban Design and Specifications Program. Water main installation shall be per Municipal Water Utility of the City of Cedar Falls Water Main Materials and Installation of Water Mains and their Appurtenances Standards as approved and amended February 14, 2020.

Links to both documents can be found on the City’s website at:
www.cedarfalls.com/designstandards 30

DIVISION 4 – Supplemental Plans and Specifications

SUPPLEMENTAL SPECIFICATIONS - BID ITEMS 31-34

**NOTICE OF PUBLIC HEARING ON PLANS, SPECIFICATIONS,
FORM OF CONTRACT, AND ESTIMATE OF COST FOR THE
HUDSON ROAD & W RIDGEWAY AVENUE INTERSECTION
IMPROVEMENTS
CITY OF CEDAR FALLS, IOWA**

TO ALL TAXPAYERS OF THE CITY OF CEDAR FALLS, IOWA, AND OTHER PERSONS INTERESTED:

Public notice is hereby given that the City Council of the City of Cedar Falls, Iowa, will conduct a Public Hearing on Plans, Specifications, Form of Contract, and Estimated Total Cost for the construction of the HUDSON ROAD & W RIDGEWAY AVENUE INTERSECTION IMPROVEMENTS in said City at 7:00 p.m. on the 6th day of February 2023, said meeting to be held in the Council Chambers in the City Hall, 220 Clay Street, Cedar Falls, Iowa.

Said Plans, Specifications, Form of Contract, and Estimated Total Cost are now on file in the office of the City Clerk in the City Hall in Cedar Falls, Iowa, and may be inspected by any persons interested.

Any person interested may appear at said meeting of the City Council for the purpose of making objections to said Plans, Specifications, Contract, or Estimated Total Cost of making said improvement.

This notice given by order of the City Council of the City of Cedar Falls, Iowa.

City of Cedar Falls, Iowa

By: _____

Jacqueline Danielsen, MMC

City Clerk

NOTICE TO BIDDERS
CITY OF CEDAR FALLS PUBLIC IMPROVEMENTS PROJECT
HUDSON ROAD & W RIDGEWAY AVENUE INTERSECTION
IMPROVEMENTS

Time and Place of Pre-bid Meeting: There will NOT be a pre-bid meeting.

Time and Place for Filing Sealed Proposals: Proposals will only be accepted electronically on the Quest CDN website before 2:00 p.m. on the 9th day of February 2023.

Time and Place Sealed Proposals will be Opened and Considered: Sealed proposals will be publicly opened online at 2:00 p.m. on the 9th day of February 2023 at www.questcdn.com, for consideration by the City of Cedar Falls City Council at its meeting at 7:00 PM on the 20th day of February 2023 or at such later time and place as may be fixed. The City of Cedar Falls reserves the right to reject any and all proposals including without limitation, nonconforming, nonresponsive, unbalanced, or conditional bids.

Time for Commencement and Completion of Work: The work under the proposed contract shall commence within ten (10) calendar days after the date set forth in the written Notice to Proceed and shall be performed regularly and diligently throughout the duration of the project. Contractor shall fully complete the project no later than September 30th, 2023.

Bid Security: Bidders shall provide a bid security in the amount defined in the Instructions to Bidders- Division 1 Section 05. A scanned copy of the Bid Bond must be included with the online bid submitted at www.questcdn.com.

Performance and Payment Bonds: The successful Bidder shall furnish to the City a performance bond in an amount equal to one hundred percent (100%) of the contract price, guaranteeing faithful performance of the contract and guaranteeing the completed project against defective workmanship and materials for a period of two (2) years from and after completion and acceptance by the City. The successful Bidder shall also provide a payment bond in an amount equal to one hundred percent (100%) of the contract price guaranteeing payment of all persons supplying labor and materials, or both, in the execution of the work provided for in the contract.

Contract Documents: The contract documents are available at www.cedarfalls.com/QuestCDN and www.questcdn.com . This contract is QuestCDN project number #8315726. A contractor may view the contract documents at no cost prior to deciding to become a Planholder. To be considered a Planholder for bids, a contractor must register with QuestCDN.com. Registering as a planholder is recommended for all prime contractors and subcontractors as Planholders will receive automatic notice of addenda and other contract document updates via QuestCDN. Contact QuestCDN Customer Support at (952) 233-1632 or info@questcdn.com for assistance in membership registration, downloading digital project information and vBid online bid submittal questions. To access the electronic bid form, download the project documents and click the online bid button at the top of the bid advertisement page. Bids will only be received and accepted via the online electronic bid service through QuestCDN.com. To access the electronic bid form, download the project documents and click on the online bid button at the top of the bid advertisement page. Prospective bidders must be on the Planholder list through QuestCDN for bids to be accepted.

Downloading electronic contract documents is strongly encouraged, but hard copies of the project documents may be obtained from Snyder & Associates, Inc. 5005 Bowling Street SW, Suite A

Cedar Rapids, IA 52404 at no cost. Those desiring to obtain hard copies must make an appointment to pick up the documents by calling 319.362.9394 and asking for Patricia Foote. No drop-ins will be allowed.

If any prospective bidder is in doubt as to the true meaning of any parts of the contract documents, the bidder may request an interpretation from the Engineer, in writing, through email. Questions received less than five (5) days prior to the date for opening bids may not be answered.

Contact individuals shall be as follows:

Luke Anderson, PE, CFM
 City of Cedar Falls
 Department of Public Works
 220 Clay Street
 Cedar Falls, IA 50613
 Luke.Anderson@cedarfalls.com

Any interpretation of the contract documents will be made in writing and only by addendum with online notification given to bidders. Only questions answered by Addenda will be binding. Oral and other interpretations or clarifications will be without legal effect. Addenda may be issued to clarify, correct or change the contract documents as deemed advisable by the City of Cedar Falls or the Engineer of record.

Preference for Iowa Products and Labor: By virtue of statutory authority, a preference will be given to products and provisions grown and coal produced within the State of Iowa.

In accordance with Iowa statutes, a resident bidder shall be allowed a preference as against a nonresident bidder from a state or foreign country if that state or foreign country gives or requires any preference to bidders from that state or foreign country, including but not limited to any preference to bidders, the imposition of any type of labor force preference, or any other form of preferential treatment to bidders or laborers from that state or foreign country. The preference allowed shall be equal to the preference given or required by the state or foreign country in which the nonresident bidder is a resident. In the instance of a resident labor force preference, a nonresident bidder shall apply the same resident labor force preference to a public improvement in this state as would be required in the construction of a public improvement by the state or foreign country in which the nonresident bidder is a resident.

Failure to submit a fully completed Bidder Status Form with the bid may result in the bid being deemed nonresponsive and rejected.

Sales Tax: Contractors and approved subcontractors will be provided a Sales Tax Exemption Certification to purchase building materials, supplies or equipment to be used in the performance of this project. Products utilized in the construction of this project shall be exempt from tax as provided by Code of Iowa Sections 423.2 and 423.45.

Project Description: This project generally consists of the installation of traffic signals at the intersection of Hudson Road and Ridgeway Avenue, and landscaping within the center median of two roundabouts along Prairie Parkway, at the intersections with Prairie View Road and Brandilynn Boulevard.

Published upon order of the City Council of Cedar Falls, Iowa.

CITY OF CEDAR FALLS, IOWA

BY: _____

Jacqueline Danielsen, MMC
City Clerk

DIVISION I – Instructions to Bidders

The work comprising the HUDSON ROAD & W RIDGEWAY AVENUE INTERSECTION IMPROVEMENTS shall be constructed in accordance with the 2022 Edition of the SUDAS and as further modified by the City of Cedar Falls' Supplemental Specifications and the special provisions included in the contract documents. The terms used in the contract revision of the documents are defined in said Standard Specifications.

Before submitting your bid, please review the requirements of "Division One, General Provisions and Covenants", in particular the sections regarding proposal requirements, bonding, contract execution, and insurance requirements. Please be certain that all documents have been completed properly; as failure to complete and sign all documents and to comply with the requirements listed below can cause your bid not to be read.

00 Pre-bid Meeting

There will NOT be a pre-bid meeting.

01 Definition and Terms

Add the following to Standard Specification Section 1010 – 1.03:

Code of Iowa: The latest edition of the Code of Iowa

Engineer: The City Engineer of Cedar Falls, Iowa or an authorized representative.

Owner: The City of Cedar Falls, Iowa acting through its City Council.

Project: HUDSON ROAD & W RIDGEWAY AVENUE INTERSECTION
IMPROVEMENTS
Project No(s). TS-000-3294

02 Qualification of the Bidder

Add the following to Standard Specification Section 1020 – 1.01:

To demonstrate bidder's qualifications to perform the work, within five days of the Owners request, bidder shall submit written evidence such as may be called for below:

The address and description of the bidder's place of business; The number of years engaged in the contracting business under the present firm name, and the name of the state where incorporated; A list of the property and equipment available to the bidder to evaluate if the bidder can complete the work in accordance with the bidding documents; A financial statement of the bidder showing that the bidder has the financial resources to meet all obligations incidental to the work; The bidder's performance record giving the description, location, and telephone number of similar projects constructed in a satisfactory manner by the bidder; A list of projects presently under contract, the approximate contract amount and the percent of completion of each; A list of contracts

which resulted in lawsuits; A list of contracts defaulted; A statement of the bidder indicating whether or not the bidder has ever filed bankruptcy while performing work of a like nature or magnitude; A list of officers of the firm who, while in the employ of the firm or the employ of previous firms, were associated with contracts which resulted in lawsuits, contracts defaulted or filed for bankruptcy; The technical experience of personnel guaranteed to be employed in responsible charge of the work stating whether the personnel have or have not performed satisfactorily on other contracts of like nature and magnitude or comparable difficulty at similar rate of progress; Such additional information as will assist the Owner in determining whether the bidder is adequately prepared to fulfill the contract. Owner's decision as to qualifications of the bidder will be final.

The Owner hereby notifies all bidders that it will affirmatively ensure that in any contract entered into pursuant to this advertisement, disadvantaged business enterprises will be afforded full opportunity to submit bids in response to this invitation and will not be discriminated against on the grounds of race, color or national origin in consideration for an award.

03 Contents of the Proposal Forms

Add the following to Standard Specification Section 1020 – 1.02:

The contract documents are available at www.cedarfalls.com/QuestCDN and www.questCDN.com. This contract is QuestCDN project number #8315726. A contractor may view the contract documents at no cost prior to deciding to become a Planholder. To be considered a Planholder for bids, a contractor must register with QuestCDN.com. Registering as a planholder is recommended for all prime contractors and subcontractors as Planholders will receive automatic notice of addenda and other contract document updates via QuestCDN. Contact QuestCDN Customer Support at (952) 233-1632 or info@questcdn.com for assistance in membership registration, downloading digital project information and vBid online bid submittal questions. To access the electronic bid form, download the project documents and click the online bid button at the top of the bid advertisement page. Bids will only be received and accepted via the online electronic bid service through QuestCDN.com. To access the electronic bid form, download the project documents and click on the online bid button at the top of the bid advertisement page. Prospective bidders must be on the Planholder list through QuestCDN for bids to be accepted.

04 Taxes

Add the following to Standard Specification Section 1020 – 1.08:

Contractors and approved subcontractors will be provided a Sales Tax Exemption Certification to purchase building materials, supplies or equipment to be used in the performance of this project. Products utilized in the construction of this project will be exempt from tax as provided by Code of Iowa Sections 423.2 and 423.45.

05 Submission of the Proposal, Identity of Bidder and Bid Security

Add the following to Standard Specification Section 1020 – 1.12:

The bid security must be in the minimum amount of 10% of the total bid amount including all add alternates (do not deduct the amount of deduct alternates). The bid security shall be in the form of a cashier's check or certified check drawn on a state-chartered or federally chartered bank, or a certified share draft drawn on a state-chartered or federally chartered credit union, or a bidder's bond with corporate surety satisfactory to the City. The bid bond must be submitted on the enclosed Bid Bond form, as no other bid bond forms are acceptable. All signatures on the bid bond must be original signatures in ink; facsimile (fax) of any signature on the bid bond is not acceptable. Bid security other than said bid bond shall be made payable to City Clerk of the City of Cedar Falls”.

“Miscellaneous Bank checks”, as well as “Money Orders” and “Traveler’s Checks” issued by persons, firms or corporations licensed under Code of Iowa Chapter 533B are not acceptable bid security.

Proposals will only be accepted electronically on the Quest CDN website. Bidders will also be required to submit the following forms online with their bid: bid security, bidder status form and non-collusion Affidavit.

**FORM OF PROPOSAL
HUDSON ROAD & W RIDGEWAY AVENUE INTERSECTION
IMPROVEMENTS
PROJECT NO. TS-000-3294
CITY OF CEDAR FALLS, IOWA**

To the Mayor and City Council
City of Cedar Falls, Iowa

The undersigned hereby certifies that _____ have personally and carefully examined the specifications, general conditions, and form of contract annexed hereto. Having made such examination, the undersigned hereby proposes to construct the improvements for the HUDSON ROAD & W RIDGEWAY INTERSECTION IMPROVEMENTS in accordance with the plans and specifications on file in the office of the City Clerk, the published Notice to Bidders and the Form of Contract, herewith, complying with all the laws of the State of Iowa, and the Rules, Regulations and Ordinances of the City of Cedar Falls, and to the satisfaction of the City Council of the City of Cedar Falls, Iowa, including the guaranteeing of this Project for a period of two (2) years from the date of final acceptance thereof at the following prices, to-wit:

BID ITEM #	DESCRIPTION	UNITS	QUANTITY	UNIT PRICE	EXTENDED PRICE
1	Topsoil, Off-site	CY	674		
2	Excavation, Class 10	CY	2199		
3	Traffic Signal	LS	1		
4	Painted Pavement Markings, Waterborne	STA	5.77		
5	Painted Symbols and Legends	EA	4		
6	Temporary Traffic Control	LS	1		
7	Sign Panels	SF	38.3		
8	Sign Posts	LF	88		
9	Removal of Sign	EA	4		

BID ITEM #	DESCRIPTION	UNITS	QUANTITY	UNIT PRICE	EXTENDED PRICE
10	Removal and Reinstallation of Sign	EA	4		
11	Conventional Seeding, Seeding, Fertilizing, and Mulching, Type 2 Seed Mixture	AC	0.08		
12	Hydraulic Seeding, Seeding, Fertilizing, and Mulching, Type 1 Seed Mixture	AC	0.41		
13	Hydraulic Seeding, Seeding, Fertilizing, and Mulching, Type 2 Seed Mixture	AC	0.21		
14	Hydraulic Seeding, Seeding, Fertilizing, and Mulching, Type 4 Seed Mixture	AC	0.21		
15	Plants, Lump Sum, With Warranty	LS	1		
16	Mulch, Shredded Bark	CY	40		
17	Mulch, Rock	CY	8		
18	SWPPP Management	LS	1		
19	Filter Sock, 12"	LF	846		
20	Filter Sock, Removal	LF	846		
21	Temporary RECP, Type 2C	SY	403		
22	Silt Fence	LF	285		
23	Silt Fence Removal of Sediment	LF	285		
24	Silt Fence Removal of Device	LF	285		
25	Monument Preservation and Replacement	LS	1		
26	Mobilization	LS	1		
27	Concrete Washout	LS	1		
28	Monument	EA	8		
29	Limestone Edging, 6" WIDE	TON	22		
30	Electrical & Lighting	LS	1		

TOTAL BID: \$ _____

Bidders may not independently bid on selective items of work. In this project, all items constitute one indivisible work that will be let to one bidder. A unit price shall be submitted for each of the items. The successful bidder will be determined by evaluating the Total Bid shown above. Failure to submit a bid on any item, shall be just cause for disqualification of the entire proposal. Unit bids must be filled in ink, typed or computer

generated, or the bid will be rejected. The Owner reserves the right to delete any part or all of any item.

The Owner reserves the right to reject any and all bids, including without limitation, nonconforming, nonresponsive, unbalanced, or conditional bids. The Owner further reserves the right to reject the bid of any bidder whom it finds, after reasonable inquiry and evaluation, to be non-responsible. The Owner may also reject the bid of any bidder if the Owner believes that it would not be in the best interest of the project to make an award to that bidder. The Owner also reserves the right to waive all informalities not involving price, time or changes in the work.

If written notice of approval of award is mailed, telegraphed or delivered to the undersigned within thirty (30) calendar days after the opening thereof, or any time thereafter before this bid is withdrawn, the undersigned agrees to execute and deliver an agreement in the prescribed form and furnish the required bond within ten (10) calendar days after the Contract is presented to the Contractor for signature, and start work within ten (10) calendar days after the date as set forth in the written Notice to Proceed.

Bid Security in the sum of _____ in the form of _____, is submitted herewith in accordance with the Instructions to Bidders.

The bidder is prepared to submit a financial and experience statement upon request. The bidder has received the following Addendum or Addenda:

Addendum No.	_____	Date	_____
	_____		_____
	_____		_____
	_____		_____

The bidder has filled in all blanks on this Proposal.

Note: The Penalty for making false statements in offers is prescribed in 18 U.S.A., Section 1001.

Name of bidder

By

Official Address

Title

BID BOND

KNOW ALL MEN BY THESE PRESENTS, that we, _____, as Principal, and _____ as Surety are held and firmly bound unto the City of Cedar Falls, Iowa, as Obligee, hereinafter called "OBLIGEE," In the penal sum of _____ Dollars (\$_____) lawful money of the United States, for the payment of which sum will and truly be made, we bind ourselves, our heirs, executors, administrators, and successors, jointly and severally, firmly by these presents. Whereas the Principal has submitted the accompanying bid dated the _____ day of _____, 20____, for _____.

NOW THEREFORE,

- (a) If said Bid shall be rejected, or in the alternate,
- (b) If said Bid shall be accepted and the Principal shall execute and deliver a contract in the form specified and shall furnish a bond for the faithful performance of said contract, and for the payment of all persons performing labor or furnishing materials in connection therewith, and shall in all other respects perform the agreement created by the acceptance of said Bid,

Then this obligation shall be void, otherwise the same shall remain in force and effect; it being expressly understood and agreed that the liability of the Surety for any and all claims hereunder shall, in no event, exceed the penal amount of this obligation as herein stated.

By virtue of statutory authority, the full amount of this bid bond shall be forfeited to the Obligee in liquidation of damages sustained in the event that the Principal fails to execute the contract and provide the bond as provided in the specifications or by law.

The Surety, for value received, hereby stipulates and agrees that the obligations of said Surety and its bond shall be in no way impaired or affected by any extension of the time within which the Obligee may accept such Bid or execute such contract; and said Surety does hereby waive notice of any such extension.

IN WITNESS WHEREOF, the Principal and the Surety, have hereunto set their hands and seals, and such of them as are corporations, have caused their corporate seals to be hereto affixed and these presents to be signed by their proper officers this _____ day of _____, A.D., 20_____.

Principal (Seal)

By _____ (Title)

Witness

Surety (Seal)

Witness

By _____
Attorney-in-fact

Bidder Status Form**To be completed by all bidders****Part A**

Please answer "Yes" or "No" for each of the following:

- Yes No My company is authorized to transact business in Iowa.
(To help you determine if your company is authorized, please review the worksheet on the next page).
- Yes No My company has an office to transact business in Iowa.
- Yes No My company's office in Iowa is suitable for more than receiving mail, telephone calls, and e-mail.
- Yes No My company has been conducting business in Iowa for at least 3 years prior to the first request for bids on this project.
- Yes No My company is not a subsidiary of another business entity or my company is a subsidiary of another business entity that would qualify as a resident bidder in Iowa.

If you answered "Yes" for each question above, your company qualifies as a resident bidder. Please complete Parts B and D of this form.

If you answered "No" to one or more questions above, your company is a nonresident bidder. Please complete Parts C and D of this form.

To be completed by resident bidders**Part B**

My company has maintained offices in Iowa during the past 3 years at the following addresses:

Dates: ____/____/____ to ____/____/____ Address: _____

City, State, Zip: _____

Dates: ____/____/____ to ____/____/____ Address: _____

City, State, Zip: _____

Dates: ____/____/____ to ____/____/____ Address: _____

You may attach additional sheet(s) if needed.

City, State, Zip: _____

To be completed by non-resident bidders**Part C**

1. Name of home state or foreign country reported to the Iowa Secretary of State:

2. Does your company's home state or foreign country offer preferences to bidders who are residents? Yes No

3. If you answered "Yes" to question 2, identify each preference offered by your company's home state or foreign country and the appropriate legal citation.

You may attach additional sheet(s) if needed.

To be completed by all bidders**Part D**

I certify that the statements made on this document are true and complete to the best of my knowledge and I know that my failure to provide accurate and truthful information may be a reason to reject my bid.

Firm Name: _____

Signature: _____

Date: _____

**You must submit the completed form to the governmental body requesting bids
per 875 Iowa Administrative Code Chapter 156.**

This form has been approved by the Iowa Labor Commissioner.

309-6001 02-14

Worksheet: Authorization to Transact Business

This worksheet may be used to help complete Part A of the Resident Bidder Status form. If at least one of the following describes your business, you are authorized to transact business in Iowa.

- Yes No My business is currently registered as a contractor with the Iowa Division of Labor.
- Yes No My business is a sole proprietorship and I am an Iowa resident for Iowa income tax purposes.
- Yes No My business is a general partnership or joint venture. More than 50 percent of the general partners or joint venture parties are residents of Iowa for Iowa income tax purposes.
- Yes No My business is an active corporation with the Iowa Secretary of State and has paid all fees required by the Secretary of State, has filed its most recent biennial report, and has not filed articles of dissolution.
- Yes No My business is a corporation whose articles of incorporation are filed in a state other than Iowa, the corporation has received a certificate of authority from the Iowa secretary of state, has filed its most recent biennial report with the secretary of state, and has neither received a certificate of withdrawal from the secretary of state nor had its authority revoked.
- Yes No My business is a limited liability partnership which has filed a statement of qualification in this state and the statement has not been canceled.
- Yes No My business is a limited liability partnership which has filed a statement of qualification in a state other than Iowa, has filed a statement of foreign qualification in Iowa and a statement of cancellation has not been filed.
- Yes No My business is a limited partnership or limited liability limited partnership which has filed a certificate of limited partnership in this state, and has not filed a statement of termination.
- Yes No My business is a limited partnership or a limited liability limited partnership whose certificate of limited partnership is filed in a state other than Iowa, the limited partnership or limited liability limited partnership has received notification from the Iowa secretary of state that the application for certificate of authority has been approved and no notice of cancellation has been filed by the limited partnership or the limited liability limited partnership.
- Yes No My business is a limited liability company whose certificate of organization is filed in Iowa and has not filed a statement of termination.
- Yes No My business is a limited liability company whose certificate of organization is filed in a state other than Iowa, has received a certificate of authority to transact business in Iowa and the certificate has not been revoked or canceled.

NON-COLLUSION AFFIDAVIT OF PRIME BIDDER
PROJECT NO(S): TS-000-3294

STATE OF _____

ss

COUNTY OF _____

_____, being first duly sworn, deposes and says that:

(1) We are _____ of _____
(Owner, partner, officer, representative, or agent)

_____, the Bidder that has submitted the attached bid:

(2) We are fully informed respecting the preparation and contents of the attached bid and of all pertinent circumstances respecting such bid:

(3) Such bid is genuine and is not a collusive or sham bid:

(4) Neither the said Bidder nor any of its officers, partners, Owners, agents, representatives, employees or parties in interest, including this affiant, has in any way colluded, conspired, connived or agreed, directly or indirectly, with any other Bidder, firm or person to submit a collusive or sham bid in connection with the Contract for which the attached bid has been submitted or to refrain from bidding in connection with such Contract, or has in any manner, directly or indirectly, sought by agreement or collusion or communication or conference with any other Bidder, firm or person to fix the price or prices in the attached bid or of any other Bidder, or, to fix any overhead, profit or cost element of the bid price of any other Bidder, or to secure through any collusion, conspiracy, connivance, or unlawful agreement any advantage against the City of Cedar Falls, Iowa, or any person interested in the proposed Contract; and

(5) The price or prices quoted in the attached bid are fair and proper and are not tainted by a collusion, conspiracy, connivance or unlawful agreement on the part of the Bidder or any of its agents, representatives, Owners, employees or parties in interest, including this affiant.

Signed

Title

Subscribed and sworn to before me

this _____ day of _____, 20_____

Title

My Commission expires _____.

FORM OF CONTRACT

This Contract entered into in quadruplicate at Cedar Falls, Iowa, this ____ day of _____, 2023, by and between the City of Cedar Falls, Iowa, hereinafter called the Owner, and _____ of _____, hereinafter called the Contractor.

WITNESSETH:

The Contractor hereby agrees to furnish all labor, tools, materials and equipment and construct the public improvement consisting of: HUDSON ROAD & W RIDGEWAY INTERSECTION IMPROVEMENTS, Project No(s). TS-000-3294 all in the City of Cedar Falls, Iowa, ordered to be constructed by the City Council of the City of Cedar Falls, Iowa, by Resolution duly passed on the 16th day of January 2023 and shown and described in the Plans and Specifications therefore now on file with the City Clerk of said City.

Said improvement shall be constructed strictly in accordance with said Plans and Specifications.

The following parts of the Plans and Specifications for said Project No(s). TS-000-3294 attached hereto shall be made a part of this contract as fully as though set out herein verbatim:

- a. Resolution ordering construction of the improvement
- b. Plans
- c. Notice of Public Hearing on Plans and Specifications
- d. Notice to Bidders
- e. Instructions to Bidders
- f. Supplemental Conditions
- g. General Conditions
- h. Project Specifications
- i. Form of Proposal
- j. Performance, Payment, and Maintenance Bond
- k. Form of Contract
- l. Non-collusion Affidavit of Prime Bidder
- m. Bidders Status Form

In Witness whereof, this Contract has been executed in quadruplicate on the date first herein written.

Contractor

CITY OF CEDAR FALLS, IOWA

By _____
Robert M. Green, Mayor

Attest: _____
Jacqueline Danielsen, MMC
City Clerk

Performance, Payment and Maintenance Bond

SURETY BOND NO. _____

KNOW ALL BY THESE PRESENTS:

That we, _____, as Principal (hereinafter the “Contractor” or “Principal” and _____ as Surety are held and firmly bound unto CITY OF CEDAR FALLS, IOWA, as Obligee (hereinafter referred to as “the Owner”), and to all persons who may be injured by any breach of any of the conditions of this Bond in the penal sum of _____ (\$_____), lawful money of the United States, for the payment of which sum, well and truly to be made, we bind ourselves, our heirs, legal representatives and assigns, jointly or severally, firmly by these presents.

The conditions of the above obligations are such that whereas said Contractor entered into a contract with the Owner, bearing date the _____ day of _____, 2023, hereinafter the “Contract”) wherein said Contractor undertakes and agrees to construct the following described improvements:

HUDSON ROAD & W RIDGEWAY INTERSECTION IMPROVEMENTS Project TS-000-3294

and to faithfully perform all the terms and requirements of said Contract within the time therein specified, in a good and workmanlike manner, and in accordance with the Contract Documents.

It is expressly understood and agreed by the Contractor and Surety in this bond that the following provisions are a part of this Bond and are binding upon said Contractor and Surety, to-wit:

1. **PERFORMANCE:** The Contractor shall well and faithfully observe, perform, fulfill, and abide by each and every covenant, condition, and part of said Contract and Contract Documents, by reference made a part hereof, for the above referenced improvements, and shall indemnify and save harmless the Owner from all outlay and expense incurred by the Owner by reason of the Contractor’s default or failure to perform as required. The Contractor shall also be responsible for the default or failure to perform as required under the Contract and Contract Documents by all its subcontractors, suppliers, agents, or employees furnishing materials or providing labor in the performance of the Contract.
2. **PAYMENT:** The Contractor and the Surety on this Bond hereby agreed to pay all just claims submitted by persons, firms, subcontractors, and corporations furnishing materials for or performing labor in the performance of the Contract on account of which this Bond is given, including but not limited to claims for all amounts due for labor, materials, lubricants, oil, gasoline, repairs on machinery, equipment, and tools, consumed or used by the Contractor or any subcontractor, wherein the same are not satisfied out of the portion of the contract price the Owner is required to retain until completion of the improvement, but the Contractor and Surety shall not be liable to said persons, firms, or corporations unless the claims of said claimants against said portion of the contract price shall have been established as provided by law. The Contractor and Surety hereby bind themselves to the obligations and conditions set forth in Chapter 573 of the Iowa Code, which by this reference is made a part hereof as though fully set out herein.

3. MAINTENANCE: The Contractor and the Surety on this Bond hereby agree, at their own expense:

- A. To remedy any and all defects that may develop in or result from work to be performed under the Contract within the period of 2 year (s) from the date of acceptance of the work under the Contract, by reason of defects in workmanship or materials used in construction of said work;
- B. To keep all work in continuous good repair; and
- C. To pay the Owner's reasonable costs of monitoring and inspection to assure that any defects are remedied, and to repay the Owner all outlay and expense incurred as a result of Contractor's and Surety's failure to remedy any defect as required by this section.

Contractor's and Surety's agreement herein made extends to defects in workmanship or materials not discovered or known to the Owner at the time such work was accepted.

4. GENERAL: Every Surety on this Bond shall be deemed and held bound, any contract to the contrary notwithstanding, to the following provisions:

- A. To consent without notice to any extension of time to the Contractor in which to perform the Contract;
- B. To consent without notice to any change in the Contract or Contract Documents, which thereby increases the total contract price and the penal sum of this bond, provided that all such changes do not, in the aggregate, involve an increase of more than 20% of the total contract price, and that this bond shall then be released as to such excess increase; and
- C. To consent without notice that this Bond shall remain in full force and effect until the Contract is completed, whether completed within the specified contract period, within an extension thereof, or within a period of time after the contract period has elapsed and the liquidated damage penalty is being charged against the Contractor.

The Contractor and every Surety on the bond shall be deemed and held bound, any contract to the contrary notwithstanding, to the following provisions:

- D. That no provision of this Bond or of any other contract shall be valid that limits to less than five years after the acceptance of the work under the Contract the right to sue on this Bond.
- E. That as used herein, the phrase "all outlay and expense" is not to be limited in any way, but shall include the actual and reasonable costs and expenses incurred by the Owner including interest, benefits, and overhead where applicable. Accordingly, "all outlay and expense" would include but not be limited to all contract or employee expense, all equipment usage or rental, materials, testing, outside experts, attorney's fees (including overhead expenses of the Owner's staff attorneys), and all costs and expenses of litigation as they are incurred by the Owner. It is intended the Contractor and Surety will defend and indemnify the Owner on all claims made against the Owner on account of Contractor's failure to perform as required in

the Contract and Contract Documents, that all agreements and promises set forth in the Contract and Contract Documents, in approved change orders, and in this Bond will be fulfilled, and that the Owner will be fully indemnified so that it will be put into the position it would have been in had the Contract been performed in the first instance as required.

In the event the Owner incurs any “outlay and expense” in defending itself against any claim as to which the Contractor or Surety should have provided the defense, or in the enforcement of the promises given by the Contractor in the Contract, Contract Documents, or approved change orders, or in the enforcement of the promises given by the Contractor and Surety in this Bond, the Contractor and Surety agree that they will make the Owner whole for all such outlay and expense, provided that the Surety’s obligation under this bond shall not exceed 125% of the penal sum of this bond.

In the event that any actions or proceedings are initiated regarding this Bond, the parties agree that the venue thereof shall be in the Iowa District Court for Polk County, State of Iowa. If legal action is required by the Owner to enforce the provisions of this Bond or to collect the monetary obligation incurring to the benefit of the Owner, the Contractor and the Surety agree, jointly, and severally, to pay the Owner all outlay and expense incurred therefor by the Owner. All rights, powers, and remedies of the Owner hereunder shall be cumulative and not alternative and shall be in addition to all rights, powers, and remedies given to the Owner, by law. The Owner may proceed against surety for any amount guaranteed hereunder whether action is brought against the Contractor or whether Contractor is joined in any such action(s) or not.

NOW THEREFORE, the condition of this obligation is such that if said Principal shall faithfully perform all the promises of the Principal, as set forth and provided in the Contract, in the Contract Documents, and in this Bond, then this obligation shall be null and void, otherwise it shall remain in full force and effect.

When a work, term, or phrase is used in this Bond, it shall be interpreted or construed first as defined in this Bond, the Contract, or the Contract Documents; second, if not defined in the Bond, Contract, or Contract Documents, it shall be interpreted or construed as defined in applicable provisions of the Iowa Code; third, if not defined in the Iowa Code, it shall be interpreted or construed according to its generally accepted meaning in the construction industry; and fourth, if it has no generally accepted meaning in the construction industry, it shall be interpreted or construed according to its common or customary usage.

Failure to specify or particularize shall not exclude terms or provisions not mentioned and shall not limit liability hereunder. The Contract and Contract Documents are hereby made a part of this Bond.

Project No(s). TS-000-3294

Witness our hands, in triplicate, this _____ day of _____, 2023.

Surety Countersigned By: **PRINCIPAL:**

Signature of Agent

Contractor

By: _____
Signature

Printed Name of Agent

Title

Company Name

SURETY:

Company Address

Surety Company

City, State, Zip Code

By: _____
Signature Attorney-in-Fact Officer

Company Telephone Number

Printed Name of Attorney-in-Fact Officer

Company Name

Company Address

FORM APPROVED BY:

City, State, Zip Code

Attorney for Owner

Company Telephone Number

NOTE:

1. All signatures on this performance, payment, and maintenance bond must be original signatures in ink; copies, facsimile, or electronic signatures will not be accepted.
2. This bond must be sealed with the Surety's raised, embossing seal.
3. The Certificate or Power of Attorney accompanying this bond must be valid on its face and sealed with the Surety's raised, embossing seal.
4. The name and signature of the Surety's Attorney-in-Fact/Officer entered on this bond must be exactly as listed on the Certificate or Power of Attorney accompanying this bond.

NOTICE TO PROCEED

TO: _____

DATE: _____

PROJECT: HUDSON ROAD & W
RIDGEWAY INTERSECTION
IMPROVEMENTS
Cedar Falls, Iowa

You are hereby notified to commence WORK in accordance with the Agreement dated _____, 2023, within ten (10) calendar days of _____, 2023 and you are to complete the WORK as follows: furnish all labor, material and equipment necessary for construction of the HUDSON ROAD & W RIDGEWAY AVENUE INTERSECTION IMPROVEMENTS.

The work under the proposed contract shall commence within ten (10) calendar days after the date set forth in this written Notice to Proceed and shall be performed regularly and diligently through the duration of the project. Contractor shall fully complete the project no later than November 10th, 2023. Liquidated damages in the amount of \$1,000 per calendar day will be assessed for work not completed within the designated contract term.

City of Cedar Falls, Iowa

(OWNER)

By _____
Title _____

DIVISION 2 – Special Provisions

Special Provisions are intended to amend or supplement the General Provisions and Covenants of the SUDAS Standard Specifications. All sections that are not amended or supplemented remain in full force and effect.

01 Award of Contract

Add the following to Standard Specification Section 1030 – 1.03:

The Owner shall have the right to accept Alternates in any order or combination, unless otherwise specifically provided in the Bidding Documents. The low Bidder shall be determined on the basis of the Base Bid.

The lowest responsive bidder shall be required to furnish a performance, payment and maintenance bond in the sum equal to one hundred (100%) percent of the total bid. The maintenance bond shall guarantee the maintenance of the improvements for a period of two (2) years from and after its completion and acceptance by the City of Cedar Falls.

02 Availability of Site

Add the following to Standard Specification Section 1050 – 1.04:

During construction of this project, the Contractor shall be required to coordinate all operations with those of other Contractors/event staff working within the same area of the following projects and/or events:

- 1) Cedar Falls Utilities Gas Main and Water Main Replacement Projects
- 2) Cedar Falls Utilities Overhead to Underground Electric Conversion.
- 3) UNI Fall Classes Resume – August 2023
- 4) Cedar Falls Public Schools Resume – August 2023
- 5) UNI Home Football Games – September through November 2023
- 6) UNI Homecoming – September/October 2023

03 Protection of Line and Grade Stakes

Add the following to Standard Specification Section 1050 – 1.10:

The Contractor shall notify the Engineer at least **72** hours prior to the need for survey stakes. The Contractor shall be responsible for preserving survey stakes and marks and if any survey stakes or marks are destroyed or disturbed by the Contractor, Contractor will be charged for the cost of replacing them.

04 Borrow and Waste Sites

Add the following to Standard Specification Section 1070 – 2.13:

It shall be the Contractor's responsibility to provide waste areas or disposal sites for excess material which is not desirable to be incorporated in the work involved on this project (excavation or broken concrete). No payment for overhaul will be allowed for material hauled to these sites. The Engineer shall review all proposed disposal sites and determine the acceptability of each. Overhaul will not be measured or paid for but will be considered incidental to pavement removal or roadway excavation on this project.

05 Contract Time

Add the following to Standard Specification Section 1080 – 1.02:

The work under the proposed contract shall commence within ten (10) calendar days after the date set forth in the written Notice to Proceed and shall be performed regularly and diligently throughout the duration of the project. Contractor shall fully complete the project no later than September 30th, 2023.

06 Work Progress and Schedule

Add the following to Standard Specification Section 1080 – 1.03:

The progress of the work shall be such that at the expiration of one-fourth of the calendar days, one-eighth of the work shall be completed; at the expiration of one-half of the calendar days, three-eighths of the work shall be completed; at the expiration of three-fourths of the calendar days, the work shall be three-fourths completed, and the whole work shall be completed at the expiration of the calendar days.

07 Weekly Record of Calendar Days

Add the following to Standard Specification Section 1080 – 1.06:

Work shall not begin before 6:00 a.m. and shall stop at sunset. Work on Sundays shall be allowed only after prior approval by the Engineer.

08 Liquidated Damages

Add the following to Standard Specification Section 1080 – 1.12:

Liquidated damages in the amount of one thousand (\$1,000.00) dollars per calendar day will be assessed for work not completed within the designated contract term as described in the Notice to Proceed.

09 Progress Payments and Vouchers

Add the following to Standard Specification Section 1090 – 1.01:

Pay estimates will be submitted to the City Council for approval on the First and Third Mondays of each month.

Payment to the Contractor will be made in cash from such cash funds of said City as may be legally used for said purposes, including the proceeds of the Local Option Tax and General Obligation Bonds. Any other combination of funds may be used at the discretion of the City Council.

See Division 2 – Special Provisions Section 06- Contract time for liquidated damages for Intermediate calendar days.

Before final payment is made, the Contractor shall furnish vouchers showing that all subcontractors and all persons furnishing labor and materials have been fully paid for such materials and labor and that the City may retain the last month's payment for a period of ninety (90) calendar days following such completion and approval, unless satisfied that material and laborers have been paid in full.

10 Pollution Prevention Plan

1. Site Description

This project generally consists of the installation of traffic signals at the intersection of Hudson Road and Ridgeway Avenue, and landscaping within the center median of two roundabouts along Prairie Parkway, at the intersections with Prairie View Road and Brandilynn Boulevard.

Access to the site shall be from adjacent City right-of-way.

2. Erosion and Sediment Controls

Construction activities that disturb subgrade soils are shown in the construction staging plan as included in the Project plan set. The primary means of controlling silt movement during construction is by minimizing the exposure of subgrade soils by way of a designated staging plan. In addition, sediment filters shall be installed on intake wells in sump locations and at the low point of the construction stage. Sediment filters shall also be placed on finished intake openings until the areas between the back of curb and the existing undisturbed grass are sodded or have established growth from seeding.

Stabilizing of all disturbed areas shall be by sodding or seeding as shown in the Project plan as soon as practical after completion of the backfilling of the curbs and the placement of the topsoil. The Contractor shall be responsible for installation and maintenance of all erosion control measures as described in the Project plan. The Contractor may elect to delegate portions of these tasks to subcontractors.

All contractors operating on the site shall take efforts to prevent contamination of storm water runoff, groundwater and soils by hazardous material and/or pollutants caused by work operations or encountered in their work. All waste building materials and supplies must be removed from the site. If construction equipment maintenance or repair is performed on the site, provisions must be made to capture and remove any lubricants or other fluids.

The Contractor shall notify the Owner immediately upon finding a hazardous material contamination either existing at the site or caused by construction activities.

Each and every Contractor shall be responsible to the Owner to:

1. Execute Contractor's part of the Pollution Prevention Plan as described.
2. Conduct all activities to not damage an existing erosion control measure or stabilizing vegetation. If damages occur, the Contractor shall make repairs with no additional cost to the Owner.
3. Coordinate with the Owner for installation of additional erosion control measures that may be needed during construction.

3. Storm Water Management

Storm water shall be routed by means of existing concrete curb intakes, storm sewer, and ditches. Storm water runoff volumes will not change as a result of the construction project, but storm water runoff shall be managed during construction to minimize erosion.

4. Pollution Prevention Plan Reporting and Updates

The Owner or a representative is to insure compliance with the Pollution Prevention Plan will carry out regular inspections. Owner designated and qualified personnel will inspect disturbed areas of the construction site that have not reached "final stabilization" at least once every seven (7) calendar days. Owner will be responsible for executing the Plan towards the goal of a stabilized site. Owner will make determination of Contractors compliance with the plan and may direct additional measures to be taken by any Contractor. When a plan deficiency or the occurrence of a pollutant entering the drainage system is observed, corrective action shall be taken. The Pollution Prevention Plan will be revised and modifications made to the control facilities as needed.

Intermittent reports based on site observation will be made and will become part of the pollution prevention plan. A final report and Notice of Discontinuation will be filed 30 days after final stabilization of the project has occurred.

11 METHOD OF MEASUREMENT

The Engineer will measure the items of work that have been acceptably constructed as specified in the contract documents for the HUDSON ROAD & W RIDGEWAY INTERSECTION IMPROVEMENTS project in accordance with the 2022 Edition of the SUDAS and as further modified by the “City of Cedar Falls” Supplemental Specifications to the 2021 Edition of the SUDAS Statewide Urban Design and Specifications Program and the special provisions included in the contract documents.

12 BASIS OF PAYMENT

Payment for the items listed in the Method of Measurement shall be determined by multiplying the item quantity (as determined in the Method of Measurement) by the unit price as bid on the proposal form in accordance with the 2022 Edition of the SUDAS as amended by the “City of Cedar Falls” Supplemental Specifications to the 2021 Edition of the SUDAS Statewide Urban Design and Specifications Program and the special provisions included in the contract documents.

DIVISION 3

STANDARD SPECIFICATIONS

The City of Cedar Falls has adopted the 2022 Edition of the STATEWIDE URBAN STANDARD SPECIFICATIONS FOR PUBLIC IMPROVEMENTS (SUDAS) as the City's Standard Specification.

This Standard Specification is amended by the "City of Cedar Falls" Supplemental Specifications to the 2021 Edition of the SUDAS Statewide Urban Design and Specifications Program. Water main installation shall be per Municipal Water Utility of the City of Cedar Falls Water Main Materials and Installation of Water Mains and their Appurtenances Standards as approved and amended February 14, 2020.

Links to both documents can be found on the City's website at:

www.cedarfalls.com/designstandards

DIVISION 4

SUPPLEMENTAL PLANS AND SPECIFICATIONS

All work shall be constructed as specified in the Contract documents for the HUDSON ROAD & W RIDGEWAY INTERSECTION IMPROVEMENTS in accordance with the 2022 Edition of the SUDAS as amended by the City of Cedar Falls' Supplemental Specifications to the 2021 Edition of SUDAS, except as amended or supplemented as follows:

ADD SECTION 8940 TRAFFIC SIGNS AND POSTS

PART 1 – GENERAL

Comply with Division 1 of SUDAS - General Provisions and Covenants

1.01 SECTION INCLUDES:

- A. Traffic Signs
- B. Traffic Sign Posts
- C. Removal of Signs and Posts

1.02 DESCRIPTION OF WORK

Includes requirements for traffic sign panels and posts for installation.

1.03 SUBMITTALS

Comply with Division 1 – General Provisions and Covenants.

1.04 SUBSTITUTIONS

Comply with Division 1- General Provisions and Covenants.

1.05 DELIVERY, STORAGE AND HANDLING

Comply with Division 1- General Provisions and Covenants.

1.06 SCHEDULING AND CONFLICTS

Comply with Division 1- General Provisions and Covenants.

Notify the Engineer at least 72 hours in advance of all removals.

1.07 SPECIAL REQUIREMENTS

None.

1.08 MEASUREMENT AND PAYMENT

A. Sign Panels

1. **Measurement:** Per square foot of sign area.
2. **Payment:** Per unit price per square foot of sign area as installed.

B. Sign Posts

1. **Measurement:** Per linear foot.
2. **Payment:** At unit price per linear foot.
3. **Includes:** All post sections, anchor, and associated hardware for installation of posts and Erection of signs.

C. Removal of Sign

1. **Measurement:** Each sign and post assembly will be counted.
2. **Payment:** Payment will be at the unit price for each sign and post assembly.
3. **Includes:** Unit price includes, but is not limited to, removal, disposal, and backfilling as necessary.

D. Removal and Reinstallation of Sign

1. **Measurement:** Each reinstalled sign and post assembly will be counted.
2. **Payment:** Payment will be at the unit price for each reinstalled sign and post assembly.
3. **Includes:** Unit price includes, but is not limited to removal, protection, and reinstallation. New posts, if necessary due to damage or if specified are incidental.

E. Removal and Salvage of Sign

1. **Measurement:** Each sign and post assembly will be counted.
2. **Payment:** Payment will be at the unit price for each sign and post assembly removed.
3. **Includes:** Unit price includes, but is not limited to, removal, protection, salvage as designated in the contract documents, and backfilling as necessary.

PART 2 – PRODUCTS

2.03 Sign Panels

- A. Fabricate signs from sheet aluminum in accordance with Section 4186.02 A. of the Iowa Department of Transportation Standard Specifications.
- B. Retroreflective Sheeting in accordance with Section 4186.03 of the Iowa Department of Transportation Standard Specifications.
- C. Sign fabrication in accordance with Section 4186.06 of the Iowa Department of Transportation Standard Specifications.
- D. Fastening accessories in accordance with Section 4186.09 A. of the Iowa Department of Transportation Standard Specifications.

2.04 Sign Posts

- A. Perforated Square Steel Tube, 2 inches square with 14- gauge wall, 11 feet in length.
- B. Steel in conformance with ASTM A1011, Grade 50.
- C. Average minimum yield strength after cold-forming: 60,000 psi.
- D. Corner welded, scarfed, zinc coated.
- E. Chromate conversion coating, clear organic polymer topcoat.
- F. Galvanized interior and exterior.
- G. Made in USA.

2.05 Anchor Post

- A. Perforated Square Steel Tube, 2 ¼ inch square, 12- gauge wall, 48 inch in length.
- B. Steel in conformance with ASTM A1011, Grade 50.
- C. Average minimum yield strength after cold-forming: 60,000 psi.
- D. Corner welded, scarfed, zinc coated.
- E. Chromate conversion coating, clear organic polymer topcoat.
- F. Galvanized interior and exterior.
- G. Made in USA.

2.06 Sign Post Extension

- A. Perforated Square Steel Tube, 1 ¾ inch square, 14- gauge wall, 30 inch in length.
- B. Steel in conformance with ASTM A1011, Grade 50.
- C. Average minimum yield strength after cold-forming: 60,000 psi.
- D. Corner welded, scarfed, zinc coated.
- E. Chromate conversion coating, clear organic polymer topcoat.
- F. Galvanized interior and exterior.
- G. Made in USA.

2.07 Omni-Directional Soil Stabilizing Anchor Sleeve

- A. Perforated Square Steel Tube, 2 ½ inch square, 12- gauge wall, 18 inch in length.
- B. Steel in conformance with ASTM1011, Grade 50.
- C. Average minimum yield strength after cold-forming: 60,000 psi.
- D. Corner welded, scarfed, zinc coated.
- E. Chromate conversion coating, clear organic polymer topcoat.
- F. Galvanized interior and exterior.

- G. Made in USA.
- H. Weld 4, 4 "x 12", 10- gauge triangular wing plates to each corner of the tube at 45 degree angles at 2 1/2inches from top of tube.

2.08 Medium Corner Bolt

- A. 5/16 inch diameter, 2 bend truss head, 18 grade.
- B. Steel in conformance with ASTM A307.
- C. Zinc plated in conformance with ASTM B633.
- D. Made in USA.

PART 3 – EXECUTION

3.01 Sign Panels

- A. Erect in accordance with Section 2524.03.B.1. of Iowa Department of Transportation Standard Specifications.

3.02 Sign Posts

- A. Install posts and anchors in accordance with Section 2524.03.B.3 of Iowa Department of Transportation Standard Specifications.

3.03 Sign Post Extension

- A. For use to mount street name signs above stop signs.

3.04 Omni-Directional Soil Stabilizing Anchor Sleeve

- A. For use in stabilizing sign assemblies which include multiple signs.
- B. Sleeves shall slide over the anchor stubs and line up with the top of the anchor stub.

END OF SECTION

OPINION OF PROBABLE PROJECT COSTS



HUDSON ROAD & W RIDGEWAY AVENUE INTERSECTION IMPROVEMENTS - FINAL 01/04/2023

Division 1: INT-1 & INT 2 ROUNDABOUT LANDSCAPING
 Division 2: RIDGEWAY & HUDSON ROAD TRAFFIC SIGNALS

CITY OF CEDAR FALLS

TS-000-3294
 121.1031.08

ITEM #	ITEM CODE	DESCRIPTION	UNIT	QUANTITY		UNIT PRICE	EXTENDED PRICE		TOTAL COST
				DIV 1	DIV 2		DIV 1	DIV 2	
				Roundabouts	Traffic Signal		Roundabouts	Traffic Signal	
1	2010-D-3	Topsoil, Off-site	CY	674	0	\$ 35.00	\$ 23,590.00	\$ -	\$ 23,590.00
2	2010-E	Excavation, Class 10	CY	2199	0	\$ 35.00	\$ 76,965.00	\$ -	\$ 76,965.00
3	8010-A	Traffic Signal	LS	0	1	\$ 286,000.00	\$ -	\$ 286,000.00	\$ 286,000.00
4	8020-B	Painted Pavement Markings, Waterborne	STA	0	5.77	\$ 450.00	\$ -	\$ 2,596.50	\$ 2,596.50
5	8020-G	Painted Symbols and Legends	EA	0	4	\$ 150.00	\$ -	\$ 600.00	\$ 600.00
6	8030-A	Temporary Traffic Control	LS	0.5	0.5	\$ 15,000.00	\$ 7,500.00	\$ 7,500.00	\$ 15,000.00
7	8940-A	Sign Panels	SF	32.0	6.3	\$ 60.00	\$ 1,920.00	\$ 378.00	\$ 2,298.00
8	8940-B	Sign Posts	LF	88	0	\$ 90.00	\$ 7,920.00	\$ -	\$ 7,920.00
9	8940-C	Removal of Sign	EA	4	0	\$ 150.00	\$ 600.00	\$ -	\$ 600.00
10	8940-D	Removal and Reinstallation of Sign	EA	4	0	\$ 500.00	\$ 2,000.00	\$ -	\$ 2,000.00
11	9010-A	Conventional Seeding, Fertilizing, and Mulching, Native Seed	AC	0.08	0	\$ 34,000.00	\$ 2,720.00	\$ -	\$ 2,720.00
12	9010-B	Hydraulic Seeding, Seeding, Fertilizing, and Mulching, Type 1 Seed Mixture	AC	0.41	0	\$ 5,000.00	\$ 2,050.00	\$ -	\$ 2,050.00
13	9010-B	Hydraulic Seeding, Seeding, Fertilizing, and Mulching, Type 2 Seed Mixture	AC	0	0.21	\$ 4,000.00	\$ -	\$ 840.00	\$ 840.00
14	9010-B	Hydraulic Seeding, Seeding, Fertilizing, and Mulching, Type 4 Seed Mixture	AC	0	0.21	\$ 3,500.00	\$ -	\$ 735.00	\$ 735.00
15	9030-B	Plants, Lump Sum, With Warranty	LS	1	0	\$ 41,000.00	\$ 41,000.00	\$ -	\$ 41,000.00
16	9030-999-A	Mulch, Shredded Bark	CY	40	0	\$ 270.00	\$ 10,800.00	\$ -	\$ 10,800.00
17	9030-999-B	Mulch, Rock	CY	8	0	\$ 432.00	\$ 3,456.00	\$ -	\$ 3,456.00
18	9040-A-2	SWPPP Management	LS	0.55	0.45	\$ 4,000.00	\$ 2,200.00	\$ 1,800.00	\$ 4,000.00
19	9040-D-1	Filter Sock, 12"	LF	792	54	\$ 4.00	\$ 3,168.00	\$ 216.00	\$ 3,384.00
20	9040-D-2	Filter Sock, Removal	LF	792	54	\$ 1.25	\$ 990.00	\$ 67.50	\$ 1,057.50
21	9040-E-0	Temporary RECP, Type 2C	SY	403	0	\$ 5.00	\$ 2,015.00	\$ -	\$ 2,015.00
22	9040-N-1	Silt Fence	LF	0	285	\$ 3.00	\$ -	\$ 855.00	\$ 855.00
23	9040-N-2	Silt Fence Removal of Sediment	LF	0	285	\$ 0.60	\$ -	\$ 171.00	\$ 171.00
24	9040-N-3	Silt Fence Removal of Device	LF	0	285	\$ 1.20	\$ -	\$ 342.00	\$ 342.00
25	11010-A	Monument Preservation and Replacement	LS	0	1	\$ 2,500.00	\$ -	\$ 2,500.00	\$ 2,500.00
26	11020-A	Mobilization	LS	0.55	0.45	\$ 50,000.00	\$ 27,500.00	\$ 22,500.00	\$ 50,000.00
27	11050-A	Concrete Washout	LS	1	0	\$ 2,000.00	\$ 2,000.00	\$ -	\$ 2,000.00
28	000-9999-A	Monument	EA	8	0	\$ 18,000.00	\$ 144,000.00	\$ -	\$ 144,000.00
29	000-9999-B	Limestone Edging, 6" WIDE	TON	22	0	\$ 915.00	\$ 20,130.00	\$ -	\$ 20,130.00
30	000-9999-C	Electrical & Lighting	LS	1	0	\$ 15,000.00	\$ 15,000.00	\$ -	\$ 15,000.00
CONSTRUCTION TOTAL:							\$ 397,524.00	\$ 327,101.00	\$ 724,625.00



DEPARTMENT OF PUBLIC WORKS

City of Cedar Falls
 220 Clay Street
 Cedar Falls, Iowa 50613
 Phone: 319-268-5161
 Fax: 319-268-5197
www.cedarfalls.com

MEMORANDUM
Engineering Division

TO: Honorable Mayor Robert M. Green and City Council

FROM: Matthew Tolan, EI, Civil Engineer II

DATE: January 17, 2023

SUBJECT: Oak Park Sanitary Sewer Repair Project
 City Project Number: SA-002-3182
 Request for PS&E Approval

Submitted within for City Council approval are the Plans, Specifications, and Estimate of Costs and Quantities for the Oak Park Sanitary Sewer Repair Project.

We recommend setting Monday, February 6th, 2023, at 7:00 p.m. as the date and time for the public hearing on this project and Friday, February 10, 2023 at 2:00 p.m. as the date and time for receiving and opening bids. We also request that the Notice to Bidders be published by Friday, January 20th, 2023, The Plans and Specifications will be ready for distribution to contractors on Friday, January 20th, 2023 allowing more than two (2) weeks of review before contract letting.

This project involves the installation of a lift station on Minnetonka Drive in Cedar Falls, IA, installation of 498 linear feet of force main, 166 linear feet of gravity sewer, and 66 linear feet of water main. The project also includes replacement of storm sewer and subdrain, PCC pavement and sidewalks, landscaping, electrical work, erosion control, seeding, and other miscellaneous items required to complete the work.

The total estimated cost for the construction of this project is \$442,200.00. The City will use Sanitary Sewer Revenue Bonds for the design, right of way, and construction of this project.

The Engineering Division of the Public Works Department recommends approving the Plans, Specifications, and Estimate of Costs and Quantities for the Oak Park Sanitary Sewer Repair Project.

xc: David Wicke, PE, City Engineer
 Chase Schrage, Director of Public Works

PROJECT SPECIFICATIONS FOR OAK PARK BLVD SEWER REPLACEMENT PROJECT

**Project SA-002-3182
Cedar Falls, Iowa**

ENGINEER'S CERTIFICATION	
 <p>The seal is circular with a wavy border. The text inside the seal reads: "LINDSAY R. BEAMAN" in the center, "P19971" below it, and "IOWA" at the bottom. The outer ring contains the text "LICENSED PROFESSIONAL ENGINEER" and two stars.</p>	<p>I hereby certify that this engineering document was prepared by me or under my direct personal supervision and that I am a duly licensed professional engineer under the laws of the State of Iowa.</p> <p><i>Lindsay Beaman</i> Date: <u>1/6/2023</u> Lindsay Beaman, P.E. Iowa License No. 19971 My license renewal date is December 31, 2023</p> <p>Pages or sheets covered by this seal: <u>All.</u></p>

TABLE OF CONTENTS

	<u>Page Number</u>
TITLE SHEET	1
TABLE OF CONTENTS	2-3
NOTICE OF PUBLIC HEARING	4
NOTICE TO BIDDERS	5-6
DIVISION 1 – Instruction to Bidders	
01 Definition and Terms	7
02 Qualification of the Bidder	7-8
03 Contents of the Proposal Forms	8
04 Taxes	8
05 Submission of the Proposal, Identity of Bidder and Bid Security	8-9
Form of Proposal	10-13
Bid Bond	14
Bidder Status Form	15
Authorization to transact business	16
Non-Collusion Affidavit of Prime Bidder	17
Form of Contract	18-19
Performance, Payment and Maintenance Bond	20-23
DIVISION 2 – Special Provisions	
01 Award of Contract	24
02 Availability of Site	24
03 Protection of Line and Grade Stakes	24
04 Borrow and Waste Sites	25
05 Subletting or Assignment of Contract	25
06 Contract Time	25
07 Work Progress and Schedule	25
08 Weekly record of Working Days	25
09 Liquidated Damages	26
10 Progress Payments and Vouchers	26
11 Pollution Prevention Plan	26-28
12 Method of Measurement	28
13 Basis of Payment	28

DIVISION 3 – Standard Specifications

The City of Cedar Falls has adopted the 2023 Edition of the STATEWIDE URBAN STANDARD SPECIFICATIONS FOR PUBLIC IMPROVEMENTS (SUDAS) as the City’s Standard Specification.

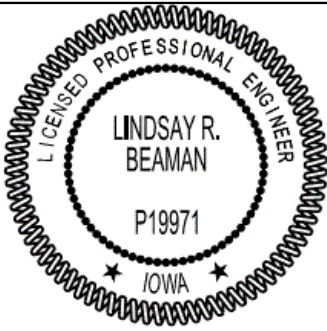
This Standard Specification is amended by the “City of Cedar Falls” Current Supplemental Specifications to SUDAS.

Links to both documents can be found on the City’s website at:

www.cedarfalls.com/designstandards 29

DIVISION 4 – Supplemental Plans and Specifications

SUPPLEMENTAL SPECIFICATIONS - BID ITEMS 30-35

SECTION 33 32 16 - PACKAGED UTILITY WASTEWATER PUMPING STATIONS Separate Numbering

DIVISION 5 – Geotechnical Engineering Report

Sanitary Sewer Ravine Crossing Separate Numbering

**NOTICE OF PUBLIC HEARING ON PLANS, SPECIFICATIONS,
FORM OF CONTRACT, AND ESTIMATE OF COST FOR THE
OAK PARK BLVD SEWER REPLACEMENT PROJECT IN THE
CITY OF CEDAR FALLS, IOWA**

TO ALL TAXPAYERS OF THE CITY OF CEDAR FALLS, IOWA, AND OTHER PERSONS INTERESTED:

Public notice is hereby given that the City Council of the City of Cedar Falls, Iowa, will conduct a Public Hearing on Plans, Specifications, Form of Contract, and Estimated Total Cost for the construction of the OAK PARK BLVD SEWER REPLACEMENT PROJECT in said City at 7:00 p.m. on the 6th day of February 2023, said meeting to be held in the Council Chambers in the City Hall, 220 Clay Street, Cedar Falls, Iowa.

Said Plans, Specifications, Form of Contract, and Estimated Total Cost are now on file in the office of the City Clerk in the City Hall in Cedar Falls, Iowa, and may be inspected by any persons interested.

Any person interested may appear at said meeting of the City Council for the purpose of making objections to said Plans, Specifications, Contract, or Estimated Total Cost of making said improvement.

This notice given by order of the City Council of the City of Cedar Falls, Iowa.

City of Cedar Falls, Iowa

By: _____

Jacqueline Danielsen, MMC

City Clerk

NOTICE TO BIDDERS
CITY OF CEDAR FALLS PUBLIC IMPROVEMENTS PROJECT
OAK PARK BLVD SEWER REPLACEMENT PROJECT

Time and Place for Filing Sealed Proposals: Sealed proposals will be received at the City Clerk's office at City Hall, 220 Clay Street, Cedar Falls, Iowa by the City Engineer or an authorized representative of the City of Cedar Falls, Iowa, before 2:00 p.m. on the 10th day of February 2023.

Time and Place Sealed Proposals will be Opened and Considered: Sealed proposals will be opened and read at 2:00 p.m. on the 10th day of February 2023 in the City Council Chambers at City Hall, 220 Clay Street, Cedar Falls, Iowa, for consideration by the City of Cedar Falls City Council at its meeting at 7:00 PM on the 20th day of February 2023 or at such later time and place as may be fixed. The City of Cedar Falls reserves the right to reject any and all proposals including without limitation, nonconforming, nonresponsive, unbalanced, or conditional bids.

Time for Commencement and Completion of Work: The work under the proposed contract shall commence within ten (10) calendar days after the date set forth in the written Notice to Proceed and shall be performed regularly and diligently throughout the duration of the project. All work shall be completed within One Hundred Twenty (120) working days. Working days will be accumulated concurrently from the date set forth in the written Notice to Proceed.

Bid Security: Each Form of Proposal shall be accompanied in a separate envelope by a bid security as defined in the Instructions to Bidders- Division 1 Section 05.

Contract Documents: Plans, specifications, and proposal forms may be obtained from the City Engineer's office, 220 Clay Street, Cedar Falls, Iowa 50613. Contract documents are also available electronically by calling 319-268-5161 for FTP site location and access rights.

Preference for Iowa Products and Labor: By virtue of statutory authority, a preference will be given to products and provisions grown and coal produced within the State of Iowa.

In accordance with Iowa statutes, a resident bidder shall be allowed a preference as against a nonresident bidder from a state or foreign country if that state or foreign country gives or requires any preference to bidders from that state or foreign country, including but not limited to any preference to bidders, the imposition of any type of labor force preference, or any other form of preferential treatment to bidders or laborers from that state or foreign country. The preference allowed shall be equal to the preference given or required by the state or foreign country in which the nonresident bidder is a resident. In the instance of a resident labor force preference, a nonresident bidder shall apply the same resident labor force preference to a public improvement in this state as would be required in the construction of a public improvement by the state or foreign country in which the nonresident bidder is a resident.

Failure to submit a fully completed Bidder Status Form with the bid may result in the bid being deemed nonresponsive and rejected.

Sales Tax: Contractors and approved subcontractors will be provided a Sales Tax Exemption Certification to purchase building materials, supplies or equipment to be used in the performance of this project. Products utilized in the construction of this project shall be exempt from tax as provided by Code of Iowa Sections 423.2 and 423.45.

Project Description: The project involves the installation of a lift station on Minnetonka Dr in Cedar Falls, IA, installation of 498 LF of force main, 166 LF of gravity sewer, and 66 LF of water main. The project also includes replacement of storm sewer and subdrain, PCC pavement and sidewalks, landscaping, electrical work, erosion control, seeding, and other miscellaneous items required to complete the work.

Published upon order of the City Council of Cedar Falls, Iowa.

CITY OF CEDAR FALLS, IOWA
BY: _____
Jacqueline Danielsen, MMC
City Clerk

DIVISION I – Instructions to Bidders

The work comprising the Oak Park Blvd Sewer Replacement Project shall be constructed in accordance with the 2023 Edition of the SUDAS and as further modified by the City of Cedar Falls' Supplemental Specifications and the special provision included in the contract documents. The terms used in the contract revision of the documents are defined in said Standard Specifications.

Before submitting your bid, please review the requirements of "Division One, General Provisions and Covenants", in particular the sections regarding proposal requirements, bonding, contract execution, and insurance requirements. Please be certain that all documents have been completed properly; as failure to complete and sign all documents and to comply with the requirements listed below can cause your bid not to be read.

01 Definition and Terms

Add the following to Standard Specification Section 1010 – 1.03:

Code of Iowa: The latest edition of the Code of Iowa

Engineer: The City Engineer of Cedar Falls, Iowa or an authorized representative.

Owner: The City of Cedar Falls, Iowa acting through its City Council.

Project: OAK PARK BLVD SEWER REPLACEMENT PROJECT
Project No. SA-002-3182

02 Qualification of the Bidder

Add the following to Standard Specification Section 1020 – 1.01:

To demonstrate bidder's qualifications to perform the work, within five days of the Owners request, bidder shall submit written evidence such as may be called for below:

The address and description of the bidder's place of business; The number of years engaged in the contracting business under the present firm name, and the name of the state where incorporated; A list of the property and equipment available to the bidder to evaluate if the bidder can complete the work in accordance with the bidding documents; A financial statement of the bidder showing that the bidder has the financial resources to meet all obligations incidental to the work; The bidder's performance record giving the description, location, and telephone number of similar projects constructed in a satisfactory manner by the bidder; A list of projects presently under contract, the approximate contract amount and the percent of completion of each; A list of contracts which resulted in lawsuits; A list of contracts defaulted; A statement of the bidder indicating whether or not the bidder has ever filed bankruptcy while performing work of a like nature or magnitude; A list of

officers of the firm who, while in the employ of the firm or the employ of previous firms, were associated with contracts which resulted in lawsuits, contracts defaulted or filed for bankruptcy; The technical experience of personnel guaranteed to be employed in responsible charge of the work stating whether the personnel have or have not performed satisfactorily on other contracts of like nature and magnitude or comparable difficulty at similar rate of progress; Such additional information as will assist the Owner in determining whether the bidder is adequately prepared to fulfill the contract. Owner's decision as to qualifications of the bidder will be final.

The Owner hereby notifies all bidders that it will affirmatively ensure that in any contract entered into pursuant to this advertisement, disadvantaged business enterprises will be afforded full opportunity to submit bids in response to this invitation and will not be discriminated against on the grounds of race, color or national origin in consideration for an award.

03 Contents of the Proposal Forms

Add the following to Standard Specification Section 1020 – 1.02:

Plans, specifications, and proposal forms may be obtained from the office of the City Engineer. Plans, specifications, and proposal forms have been approved by the City Council and are now on file for public examination in the office of the City Clerk.

04 Taxes

Add the following to Standard Specification Section 1020 – 1.08:

Contractors and approved subcontractors will be provided a Sales Tax Exemption Certification to purchase building materials, supplies or equipment to be used in the performance of this project. Products utilized in the construction of this project will be exempt from tax as provided by Code of Iowa Sections 423.2 and 423.45.

05 Submission of the Proposal, Identity of Bidder and Bid Security

Add the following to Standard Specification Section 1020 – 1.12:

The bid security must be in the minimum amount of 10% of the total bid amount including all add alternates (do not deduct the amount of deduct alternates). The bid security shall be in the form of a cashier's check or certified check drawn on a state-chartered or federally chartered bank, or a certified share draft drawn on a state-chartered or federally chartered credit union, or a bidder's bond with corporate surety satisfactory to the City. The bid bond must be submitted on the enclosed Bid Bond form, as no other bid bond forms are acceptable. All signatures on the bid bond must be original signatures in ink; facsimile (fax) of any signature on the bid bond is not acceptable. Bid security other than said bid bond shall be made payable to City Clerk of the City of Cedar Falls".

"Miscellaneous Bank checks", as well as "Money Orders" and "Traveler's Checks" issued by persons, firms or corporations licensed under Code of Iowa Chapter 533B are not acceptable bid security.

The bid shall be submitted on the Form of Proposal included herewith or on a computer printed proposal. All entries on this proposal shall be filled in ink, typed or computer printed. The bidder shall not alter the quantity, unit price or the extension that has been provided for items that have been predetermined by the contracting authority.

If the proposal is computer generated, the bidder shall submit a form titled as "Form of Proposal," followed by: the project name, project number, the City of Cedar Falls, Iowa and the bidder's name. The form shall then include the item numbers, item descriptions, and units and their quantities. The bidder shall specify a unit price in figures of dollars and cents for all pay items, the extensions for the respective unit prices and quantities in figures in a column provided for the purpose, and the total amount of the proposal obtained by adding the amounts of the several items. The form shall then conclude with the bidder's name, that of its representative and the representative's signature.

The computer generated proposal then is to be attached to the Form of Proposal included herewith, which has the following entries completed: bid security sum and form, the name of the bidder and its official address, and the bidder's representative's name, signature, and title. Also the total bid shall be completed with the entry of "see attached."

The proposal shall be submitted in a sealed envelope separate from the bid security, bidders status form and non-collusion Affidavit. The envelope shall bear the return address of the bidder and shall be addressed as follows:

To: City Clerk
City of Cedar Falls
City Hall
220 Clay Street
Cedar Falls, Iowa 50613

Proposal for: OAK PARK BLVD SEWER REPLACEMENT PROJECT
Project No. SA-002-3182

**FORM OF PROPOSAL
OAK PARK BLVD SEWER REPLACEMENT PROJECT
PROJECT NO. SA-002-3182
CITY OF CEDAR FALLS, IOWA**

To the Mayor and City Council
City of Cedar Falls, Iowa

The undersigned hereby certifies that _____ have personally and carefully examined the specifications, general conditions, and form of contract annexed hereto. Having made such examination, the undersigned hereby proposes to construct the improvements for the OAK PARK BLVD SEWER REPLACEMENT PROJECT in accordance with the plans and specifications on file in the office of the City Clerk, the published Notice to Bidders and the Form of Contract, herewith, complying with all the laws of the State of Iowa, and the Rules, Regulations and Ordinances of the City of Cedar Falls, and to the satisfaction of the City Council of the City of Cedar Falls, Iowa, including the guaranteeing of this Project for a period of two (2) years from the date of final acceptance thereof at the following prices, to-wit:

BID ITEM #	DESCRIPTION	UNITS	QUANTITY	UNIT PRICE	EXTENDED PRICE
1	Clearing and Grubbing	LS	1		
2	Topsoil, On-site	CY	190		
3	Subgrade Preparation	SY	276		
4	Subbase, 12" Modified	SY	191		
5	Removal of Structure	LS	1		
6	Compaction Testing	LS	1		
7	Trench Foundation	TON	18		

BID ITEM #	DESCRIPTION	UNITS	QUANTITY	UNIT PRICE	EXTENDED PRICE
8	Replacement of Unsuitable Backfill Material	CY	119		
9	Trench Compaction Testing	LS	1		
10	Sanitary Sewer Gravity Main, Trenched, PVC, SDR 26, 8"	LF	166		
11	Sanitary Sewer Force Main, Trenched, HDPE, 2"	LF	156		
12	Sanitary Sewer Force Main, Trenchless, HDPE, 2"	LF	300		
13	Sanitary Sewer Force Main with Casing Pipe, Trenched, HDPE, 2"	LF	42		
14	Sanitary Sewer Service Stub, PVC, SDR 23.5, 4"	LF	24		
15	Removal of Sanitary Sewer, All Types and Sizes	LF	277		
16	Sanitary Sewer Cleanout	EA	2		
17	Sanitary Sewer Abandonment, Fill and Plug	LF	50		
18	Storm Sewer, Trenched, RCP, 15"	LF	20		
19	Removal of Storm Sewer, RCP, 15"	LF	20		
20	Subdrain, Type 1, 6"	LF	50		
21	Water Main, Trenched, DIP, 6"	LF	66		
22	Water Main Fittings, 6"	EA	4		
23	Water Main Removal, 6"	LF	51		
24	Manhole, SW-303, 48"	EA	1		
25	Internal Drop Connection	EA	1		
26	External Drop Connection	EA	1		
27	Connection to Existing Manhole	EA	1		
28	Remove Manhole	EA	2		
29	Pavement, PCC, 7"	SY	171		
30	HMA Overlay	TON	28.1		
31	Removal of Sidewalk	SY	61		
32	Sidewalk, PCC, 4"	SY	61		
33	Driveway, Paved, PCC, 6"	SY	46		
34	Pavement Removal	SY	216		

BID ITEM #	DESCRIPTION	UNITS	QUANTITY	UNIT PRICE	EXTENDED PRICE
35	Temporary Traffic Control	LS	1		
36	Hydraulic Seeding, Seeding, Fertilizing, and Mulching, Slope Mix	AC	0.24		
37	Sod	SQ	42		
38	Plants with Warranty	LS	1		
39	Mulch, Shredded Bark	SF	635		
40	Landscape Boulders	EA	5		
41	SWPPP Management	LS	1		
42	Filter Sock, 12"	LF	1560		
43	Filter Sock, Removal	LF	1560		
44	Temporary RECP, Type 4	SY	245		
45	Stabilized Construction Entrance	SY	94		
46	Inlet Protection Device, Filter Sock	EA	2		
47	Inlet Protection Device, Maintenance	EA	2		
48	Lift Station Column	LS	1		
49	Mobilization	LS	1		
50	Concrete Washout	LS	1		
51	Electrical	LS	1		
52	Lift Station, Complete	LS	1		
				TOTAL BID	

Bidders may not independently bid on selective items of work. In this project, all items constitute one indivisible work that will be let to one bidder. A unit price shall be submitted for each of the items (Items 1-52). The successful bidder will be determined by evaluating the Total Bid shown above. Failure to submit a bid on any item shall be just cause for disqualification of the entire proposal. Unit bids must be filled in ink, typed or computer generated, or the bid will be rejected. The Owner reserves the right to delete any part or all of any item.

The Owner reserves the right to reject any and all bids, including without limitation, nonconforming, nonresponsive, unbalanced, or conditional bids. The Owner further reserves the right to reject the bid of any bidder whom it finds, after reasonable inquiry and evaluation, to be non-responsible. The Owner may also reject the bid of any bidder if the Owner believes that it would not be in the best interest of the project to make an award to that bidder. The Owner also reserves the right to waive all informalities not involving price, time or changes in the work.

If written notice of approval of award is mailed, telegraphed or delivered to the undersigned within thirty (30) calendar days after the opening thereof, or any time thereafter before this bid is withdrawn, the undersigned agrees to execute and deliver an agreement in the prescribed form and furnish the required bond within ten (10) calendar days after the Contract is presented to the Contractor for signature, and start work within ten (10) calendar days after the date as set forth in the written Notice to Proceed.

Bid Security in the sum of _____ in the form of _____, is submitted herewith in accordance with the Instructions to Bidders.

The bidder is prepared to submit a financial and experience statement upon request.

The bidder has received the following Addendum or Addenda:

Addendum No. _____ Date _____

The bidder has filled in all blanks on this Proposal.

Note: The Penalty for making false statements in offers is prescribed in 18 U.S.A., Section 1001.

Name of bidder

By

Official Address

Title

BID BOND

KNOW ALL MEN BY THESE PRESENTS, that we, _____, as Principal, and _____ as Surety are held and firmly bound unto the City of Cedar Falls, Iowa, as Obligee, hereinafter called "OBLIGEE," In the penal sum of _____ Dollars (\$_____) lawful money of the United States, for the payment of which sum will and truly be made, we bind ourselves, our heirs, executors, administrators, and successors, jointly and severally, firmly by these presents. Whereas the Principal has submitted the accompanying bid dated the _____ day of _____, 20____, for _____.

NOW THEREFORE,

- (a) If said Bid shall be rejected, or in the alternate,
- (b) If said Bid shall be accepted and the Principal shall execute and deliver a contract in the form specified and shall furnish a bond for the faithful performance of said contract, and for the payment of all persons performing labor or furnishing materials in connection therewith, and shall in all other respects perform the agreement created by the acceptance of said Bid,

Then this obligation shall be void, otherwise the same shall remain in force and effect; it being expressly understood and agreed that the liability of the Surety for any and all claims hereunder shall, in no event, exceed the penal amount of this obligation as herein stated.

By virtue of statutory authority, the full amount of this bid bond shall be forfeited to the Obligee in liquidation of damages sustained in the event that the Principal fails to execute the contract and provide the bond as provided in the specifications or by law.

The Surety, for value received, hereby stipulates and agrees that the obligations of said Surety and its bond shall be in no way impaired or affected by any extension of the time within which the Obligee may accept such Bid or execute such contract; and said Surety does hereby waive notice of any such extension.

IN WITNESS WHEREOF, the Principal and the Surety, have hereunto set their hands and seals, and such of them as are corporations, have caused their corporate seals to be hereto affixed and these presents to be signed by their proper officers this _____ day of _____, A.D., 20_____.

Principal (Seal)

By _____ (Title)

Surety (Seal)

By _____
Attorney-in-fact

Witness

Witness

Bidder Status Form

To be completed by all bidders

Part A

Please answer "Yes" or "No" for each of the following:

- Yes No My company is authorized to transact business in Iowa.
(To help you determine if your company is authorized, please review the worksheet on the next page).
- Yes No My company has an office to transact business in Iowa.
- Yes No My company's office in Iowa is suitable for more than receiving mail, telephone calls, and e-mail.
- Yes No My company has been conducting business in Iowa for at least 3 years prior to the first request for bids on this project.
- Yes No My company is not a subsidiary of another business entity or my company is a subsidiary of another business entity that would qualify as a resident bidder in Iowa.

If you answered "Yes" for each question above, your company qualifies as a resident bidder. Please complete Parts B and D of this form.

If you answered "No" to one or more questions above, your company is a nonresident bidder. Please complete Parts C and D of this form.

To be completed by resident bidders

Part B

My company has maintained offices in Iowa during the past 3 years at the following addresses:

Dates: ____/____/____ to ____/____/____ Address: _____
City, State, Zip: _____

Dates: ____/____/____ to ____/____/____ Address: _____
City, State, Zip: _____

Dates: ____/____/____ to ____/____/____ Address: _____
You may attach additional sheet(s) if needed. City, State, Zip: _____

To be completed by non-resident bidders

Part C

1. Name of home state or foreign country reported to the Iowa Secretary of State:

2. Does your company's home state or foreign country offer preferences to bidders who are residents? Yes No

3. If you answered "Yes" to question 2, identify each preference offered by your company's home state or foreign country and the appropriate legal citation.

You may attach additional sheet(s) if needed.

To be completed by all bidders

Part D

I certify that the statements made on this document are true and complete to the best of my knowledge and I know that my failure to provide accurate and truthful information may be a reason to reject my bid.

Firm Name: _____

Signature: _____ Date: _____

You must submit the completed form to the governmental body requesting bids per 875 Iowa Administrative Code Chapter 156.

This form has been approved by the Iowa Labor Commissioner.

309-6001 02-14

Worksheet: Authorization to Transact Business

This worksheet may be used to help complete Part A of the Resident Bidder Status form. If at least one of the following describes your business, you are authorized to transact business in Iowa.

- Yes No My business is currently registered as a contractor with the Iowa Division of Labor.
- Yes No My business is a sole proprietorship and I am an Iowa resident for Iowa income tax purposes.
- Yes No My business is a general partnership or joint venture. More than 50 percent of the general partners or joint venture parties are residents of Iowa for Iowa income tax purposes.
- Yes No My business is an active corporation with the Iowa Secretary of State and has paid all fees required by the Secretary of State, has filed its most recent biennial report, and has not filed articles of dissolution.
- Yes No My business is a corporation whose articles of incorporation are filed in a state other than Iowa, the corporation has received a certificate of authority from the Iowa secretary of state, has filed its most recent biennial report with the secretary of state, and has neither received a certificate of withdrawal from the secretary of state nor had its authority revoked.
- Yes No My business is a limited liability partnership which has filed a statement of qualification in this state and the statement has not been canceled.
- Yes No My business is a limited liability partnership which has filed a statement of qualification in a state other than Iowa, has filed a statement of foreign qualification in Iowa and a statement of cancellation has not been filed.
- Yes No My business is a limited partnership or limited liability limited partnership which has filed a certificate of limited partnership in this state, and has not filed a statement of termination.
- Yes No My business is a limited partnership or a limited liability limited partnership whose certificate of limited partnership is filed in a state other than Iowa, the limited partnership or limited liability limited partnership has received notification from the Iowa secretary of state that the application for certificate of authority has been approved and no notice of cancellation has been filed by the limited partnership or the limited liability limited partnership.
- Yes No My business is a limited liability company whose certificate of organization is filed in Iowa and has not filed a statement of termination.
- Yes No My business is a limited liability company whose certificate of organization is filed in a state other than Iowa, has received a certificate of authority to transact business in Iowa and the certificate has not been revoked or canceled.

FORM OF CONTRACT

This Contract entered into in quadruplicate at Cedar Falls, Iowa, this ____ day of _____, 2023, by and between the City of Cedar Falls, Iowa, hereinafter called the Owner, and _____ of _____, hereinafter called the Contractor.

WITNESSETH:

The Contractor hereby agrees to furnish all labor, tools, materials and equipment and construct the public improvement consisting of: OAK PARK BLVD SEWER REPLACEMENT PROJECT, Project No. SA-002-3182 all in the City of Cedar Falls, Iowa, ordered to be constructed by the City Council of the City of Cedar Falls, Iowa, by Resolution duly passed on the 6th day of February 2023, and shown and described in the Plans and Specifications therefore now on file with the City Clerk of said City.

Said improvement shall be constructed strictly in accordance with said Plans and Specifications.

The following parts of the Plans and Specifications for said Project No. SA-002-3182 attached hereto shall be made a part of this contract as fully as though set out herein verbatim:

- a. Resolution ordering construction of the improvement
- b. Plans
- c. Notice of Public Hearing on Plans and Specifications
- d. Notice to Bidders
- e. Instructions to Bidders
- f. Supplemental Conditions
- g. General Conditions
- h. Project Specifications
- i. Form of Proposal
- j. Performance, Payment, and Maintenance Bond
- k. Form of Contract
- l. Non-collusion Affidavit of Prime Bidder
- m. Bidders Status Form

In Witness whereof, this Contract has been executed in quadruplicate on the date first herein written.

Contractor

CITY OF CEDAR FALLS, IOWA

By _____
James P. Brown, Mayor

Attest: _____
Jacqueline Danielsen, MMC
City Clerk

Performance, Payment and Maintenance Bond

SURETY BOND NO. _____

KNOW ALL BY THESE PRESENTS:

That we, _____, as Principal (hereinafter the “Contractor” or “Principal” and _____ as Surety are held and firmly bound unto CITY OF CEDAR FALLS, IOWA, as Obligee (hereinafter referred to as “the Owner”), and to all persons who may be injured by any breach of any of the conditions of this Bond in the penal sum of _____ (\$ _____), lawful money of the United States, for the payment of which sum, well and truly to be made, we bind ourselves, our heirs, legal representatives and assigns, jointly or severally, firmly by these presents.

The conditions of the above obligations are such that whereas said Contractor entered into a contract with the Owner, bearing date the _____ day of _____, 2023, hereinafter the “Contract”) wherein said Contractor undertakes and agrees to construct the following described improvements:

**Oak Park Blvd Sewer Replacement Project
Wastewater Collection
Project SA-002-3182**

and to faithfully perform all the terms and requirements of said Contract within the time therein specified, in a good and workmanlike manner, and in accordance with the Contract Documents.

It is expressly understood and agreed by the Contractor and Surety in this bond that the following provisions are a part of this Bond and are binding upon said Contractor and Surety, to-wit:

1. **PERFORMANCE:** The Contractor shall well and faithfully observe, perform, fulfill, and abide by each and every covenant, condition, and part of said Contract and Contract Documents, by reference made a part hereof, for the above referenced improvements, and shall indemnify and save harmless the Owner from all outlay and expense incurred by the Owner by reason of the Contractor’s default or failure to perform as required. The Contractor shall also be responsible for the default or failure to perform as required under the Contract and Contract Documents by all its subcontractors, suppliers, agents, or employees furnishing materials or providing labor in the performance of the Contract.
2. **PAYMENT:** The Contractor and the Surety on this Bond hereby agreed to pay all just claims submitted by persons, firms, subcontractors, and corporations furnishing materials for or performing labor in the performance of the Contract on account of which this Bond is given, including but not limited to claims for all amounts due for labor, materials, lubricants, oil, gasoline, repairs on machinery, equipment, and tools, consumed or used by the Contractor or any subcontractor, wherein the same are not satisfied out of the portion of the contract price the Owner is required to retain until completion of the improvement, but the Contractor and Surety shall not be liable to said persons, firms, or corporations unless the claims of said claimants against said portion of the contract price shall have been established as provided by law. The Contractor and Surety hereby bind themselves to the obligations and conditions set forth in Chapter 573 of the Iowa Code, which by this reference is made a part hereof as though fully set out herein.

3. MAINTENANCE: The Contractor and the Surety on this Bond hereby agree, at their own expense:
- A. To remedy any and all defects that may develop in or result from work to be performed under the Contract within the period of 2 year (s) from the date of acceptance of the work under the Contract, by reason of defects in workmanship or materials used in construction of said work;
 - B. To keep all work in continuous good repair; and
 - C. To pay the Owner's reasonable costs of monitoring and inspection to assure that any defects are remedied, and to repay the Owner all outlay and expense incurred as a result of Contractor's and Surety's failure to remedy any defect as required by this section.

Contractor's and Surety's agreement herein made extends to defects in workmanship or materials not discovered or known to the Owner at the time such work was accepted.

4. GENERAL: Every Surety on this Bond shall be deemed and held bound, any contract to the contrary notwithstanding, to the following provisions:
- A. To consent without notice to any extension of time to the Contractor in which to perform the Contract;
 - B. To consent without notice to any change in the Contract or Contract Documents, which thereby increases the total contract price and the penal sum of this bond, provided that all such changes do not, in the aggregate, involve an increase of more than 20% of the total contract price, and that this bond shall then be released as to such excess increase; and
 - C. To consent without notice that this Bond shall remain in full force and effect until the Contract is completed, whether completed within the specified contract period, within an extension thereof, or within a period of time after the contract period has elapsed and the liquidated damage penalty is being charged against the Contractor.

The Contractor and every Surety on the bond shall be deemed and held bound, any contract to the contrary notwithstanding, to the following provisions:

- D. That no provision of this Bond or of any other contract shall be valid that limits to less than five years after the acceptance of the work under the Contract the right to sue on this Bond.
- E. That as used herein, the phrase "all outlay and expense" is not to be limited in any way, but shall include the actual and reasonable costs and expenses incurred by the Owner including interest, benefits, and overhead where applicable. Accordingly, "all outlay and expense" would include but not be limited to all contract or employee expense, all equipment usage or rental, materials, testing, outside experts, attorney's fees (including overhead expenses of the Owner's staff attorneys), and all costs and expenses of litigation as they are incurred by the Owner. It is intended the Contractor and Surety will defend and indemnify the Owner on all claims made against the Owner on account of Contractor's failure to perform as required in the Contract and Contract Documents, that all agreements and promises set forth in the Contract and Contract Documents, in approved change orders, and in this Bond will be fulfilled, and that the Owner will be fully indemnified so that it will be put into the

position it would have been in had the Contract been performed in the first instance as required.

In the event the Owner incurs any "outlay and expense" in defending itself against any claim as to which the Contractor or Surety should have provided the defense, or in the enforcement of the promises given by the Contractor in the Contract, Contract Documents, or approved change orders, or in the enforcement of the promises given by the Contractor and Surety in this Bond, the Contractor and Surety agree that they will make the Owner whole for all such outlay and expense, provided that the Surety's obligation under this bond shall not exceed 125% of the penal sum of this bond.

In the event that any actions or proceedings are initiated regarding this Bond, the parties agree that the venue thereof shall be in the Iowa District Court for Blackhawk County, State of Iowa. If legal action is required by the Owner to enforce the provisions of this Bond or to collect the monetary obligation incurring to the benefit of the Owner, the Contractor and the Surety agree, jointly, and severally, to pay the Owner all outlay and expense incurred therefor by the Owner. All rights, powers, and remedies of the Owner hereunder shall be cumulative and not alternative and shall be in addition to all rights, powers, and remedies given to the Owner, by law. The Owner may proceed against surety for any amount guaranteed hereunder whether action is brought against the Contractor or whether Contractor is joined in any such action(s) or not.

NOW THEREFORE, the condition of this obligation is such that if said Principal shall faithfully perform all the promises of the Principal, as set forth and provided in the Contract, in the Contract Documents, and in this Bond, then this obligation shall be null and void, otherwise it shall remain in full force and effect.

When a work, term, or phrase is used in this Bond, it shall be interpreted or construed first as defined in this Bond, the Contract, or the Contract Documents; second, if not defined in the Bond, Contract, or Contract Documents, it shall be interpreted or construed as defined in applicable provisions of the Iowa Code; third, if not defined in the Iowa Code, it shall be interpreted or construed according to its generally accepted meaning in the construction industry; and fourth, if it has no generally accepted meaning in the construction industry, it shall be interpreted or construed according to its common or customary usage.

Failure to specify or particularize shall not exclude terms or provisions not mentioned and shall not limit liability hereunder. The Contract and Contract Documents are hereby made a part of this Bond.

Project No. SA-002-3182

Witness our hands, in triplicate, this _____ day of _____, 2023.

Surety Countersigned By:

PRINCIPAL:

Signature of Agent

Contractor

By: _____
Signature

Printed Name of Agent

Title

SURETY:

Company Name

Surety Company

Company Address

By: _____
Signature Attorney-in-Fact Officer

City, State, Zip Code

Printed Name of Attorney-in-Fact Officer

Company Telephone Number

Company Name

FORM APPROVED BY:

Company Address

City, State, Zip Code

Attorney for Owner

Company Telephone Number

NOTE:

1. All signatures on this performance, payment, and maintenance bond must be original signatures in ink; copies, facsimile, or electronic signatures will not be accepted.
2. This bond must be sealed with the Surety's raised, embossing seal.
3. The Certificate or Power of Attorney accompanying this bond must be valid on its face and sealed with the Surety's raised, embossing seal.
4. The name and signature of the Surety's Attorney-in-Fact/Officer entered on this bond must be exactly as listed on the Certificate or Power of Attorney accompanying this bond.

DIVISION 2 – Special Provisions

Special Provisions are intended to amend or supplement the General Provisions and Covenants of the SUDAS Standard Specifications. All sections that are not amended or supplemented remain in full force and effect.

01 Award of Contract

Add the following to Standard Specification Section 1030 – 1.03:

The lowest responsive bidder shall be required to furnish a performance, payment and maintenance bond in the sum equal to one hundred (100%) percent of the total bid. The maintenance bond shall guarantee the maintenance of the improvements for a period of two (2) years from and after its completion and acceptance by the City of Cedar Falls.

02 Availability of Site

Add the following to Standard Specification Section 1050 – 1.04:

During construction of this project, the Contractor shall be required to coordinate all operations with those of other Contractors working within the same area of the following projects and/or events:

- 1) None identified

03 Protection of Line and Grade Stakes

Add the following to Standard Specification Section 1050 – 1.10:

The Contractor shall notify the Engineer at least **72** hours prior to the need for survey stakes. One set of survey stakes will be provided for each operation. The Contractor shall be responsible for preserving survey stakes and marks and if any survey stakes or marks are destroyed or disturbed by the Contractor due to construction, the Contractor will be charged for the cost of replacing them.

04 Borrow and Waste Sites

Add the following to Standard Specification Section 1070 – 2.13:

It shall be the Contractor's responsibility to provide waste areas or disposal sites for excess material which is not desirable to be incorporated in the work involved on this project (excavation or broken concrete). No payment for overhaul will be allowed for material hauled to these sites. The Engineer shall review all proposed disposal sites and determine the acceptability of each. Overhaul will not be measured or paid for but will be considered incidental to pavement removal or roadway excavation on this project.

05 Subletting or Assignment of Contract

Add the following to Standard Specification Section 1080 – 1.01:

The Contractor's own organization shall perform work amounting to not less than thirty five (35%) percent of the total contract cost unless otherwise specified. Item designated as a specialty item may be performed by subcontract, and the cost of any such specialty item as performed by subcontract may be deducted from the total cost before computing the amount of work required by the Contractor's organization.

06 Contract Time

Add the following to Standard Specification Section 1080 – 1.02:

The work on the Contract shall commence ten calendar days after the date set forth in the written Notice to Proceed and shall be completed within One Hundred Twenty (120) working days as set forth in the written Notice to Proceed.

07 Work Progress and Schedule

Add the following to Standard Specification Section 1080 – 1.03:

The progress of the work shall be such that at the expiration of one-fourth of the working days, one-eighth of the work shall be completed; at the expiration of one-half of the working days, three-eighths of the work shall be completed; at the expiration of three-fourths of the working days, the work shall be three-fourths completed, and the whole work shall be completed at the expiration of the working days.

08 Weekly Record of Working Days

Add the following to Standard Specification Section 1080 – 1.06:

Work shall not begin before 7:00 a.m. and shall stop at sunset. Work on Sundays and Holidays shall only be allowed after prior written approval by the Engineer.

09 Liquidated Damages

Add the following to Standard Specification Section 1080 – 1.12:

Liquidated damages in the amount of One Thousand (\$1000.00) dollars per working day will be assessed for each working day that the work remains uncompleted after the expiration of the contract time.

10 Progress Payments and Vouchers

Add the following to Standard Specification Section 1090 – 1.01:

Pay estimates will be submitted to the City Council for approval on the First and Third Mondays of each month.

Payment to the Contractor will be made in cash from such cash funds of said City as may be legally used for said purposes, including the proceeds of the Local Option Tax and General Obligation Bonds. Any other combination of funds may be used at the discretion of the City Council.

Before final payment is made, the Contractor shall furnish vouchers showing that all subcontractors and all persons furnishing labor and materials have been fully paid for such materials and labor and that the City may retain the last month's payment for a period of ninety (90) calendar days following such completion and approval, unless satisfied that material and laborers have been paid in full.

11 Pollution Prevention Plan

1. Site Description

The proposed Oak Park Blvd Sewer Replacement Project involves installation of a lift station on Minnetonka Dr in Cedar Falls, IA, installation of 498 LF of force main, 166 LF of gravity sewer, and 66 LF of water main. The project also includes replacement of storm sewer and subdrain, PCC pavement and sidewalks, landscaping, electrical work, erosion control, seeding, and other miscellaneous items required to complete the work.

Access to the site shall be from Minnetonka Dr and Oak Park Blvd.

2. Erosion and Sediment Controls

Construction activities that disturb soils are shown in the project plan set. The primary means of controlling silt movement during construction is by minimizing the exposure of subgrade soils by way of the Erosion Control Devices shown in the plans.

Stabilizing of all disturbed areas shall be by sodding or seeding as shown in the Project plan as soon as practical after completion of the backfilling of the curbs and/or the

placement of the topsoil. The Contractor shall be responsible for installation and maintenance of all erosion control measures as described in the Project plan. The Contractor may elect to delegate portions of these tasks to subcontractors.

All contractors operating on the site shall take efforts to prevent contamination of storm water runoff, groundwater and soils by hazardous material and/or pollutants caused by work operations or encountered in their work. All waste building materials and supplies must be removed from the site. If construction equipment maintenance or repair is performed on the site, provisions must be made to capture and remove any lubricants or other fluids.

The Contractor shall notify the Owner immediately upon finding a hazardous material contamination either existing at the site or caused by construction activities.

Each and every Contractor shall be responsible to the Owner to:

1. Execute Contractor's part of the Pollution Prevention Plan as described.
2. Conduct all activities to not damage an existing erosion control measure or stabilizing vegetation. If damages occur, the Contractor shall make repairs with no additional cost to the Owner.
3. Coordinate with the Owner for installation of additional erosion control measures that may be needed during construction.

3. Storm Water Management

Storm water shall be routed by means of concrete curb intakes and storm sewer. Concrete and plastic pipes shall be used to channel water from curb intakes to the existing main storm sewer pipes. The storm sewer pipes will range in size up to 48-inch diameter. Longitudinal sub-drains shall be included behind the curb line on both sides of the street. The sub-drains shall tie into the concrete curb intakes. The storm water collection system was designed for the 5-year storm water event in accordance with local design standards. Temporary sediment basins were not incorporated because of the limited area exposed in each stage of street construction. Sediment filters shall be incorporated in specific intakes to serve as sediment control structures during each stage. Storm water runoff volumes will not change as a result of the street construction project, but storm water runoff shall be managed during construction to minimize erosion.

4. Pollution Prevention Plan Reporting and Updates

The Owner or a representative is to insure compliance with the Pollution Prevention Plan will carry out regular inspections. Owner designated and qualified personnel will inspect disturbed areas of the construction site that have not reached "final stabilization" at least once every seven (7) calendar days. Owner will be responsible for executing the Plan towards the goal of a stabilized site. Owner will make determination of Contractors compliance with the plan and may direct additional measures to be taken by any Contractor. When a plan deficiency or the occurrence of a pollutant entering the drainage

system is observed, corrective action shall be taken. The Pollution Prevention Plan will be revised and modifications made to the control facilities as needed.

Intermittent reports based on site observation will be made and will become part of the pollution prevention plan. A final report and Notice of Discontinuation will be filed 30 days after final stabilization of the project has occurred.

5. Certification Statement

N.P.D.E.S. CERTIFICATION **PROJECT NO. SA-002-3182**

Contractor certifies under penalty of law that they understand the terms and conditions of the general National Pollutant Discharge Elimination System (NPDES) permit that authorizes the storm water discharges associated with industrial activity from the construction site as part of this certification. Further, by signing and entering into contract for this work, the contractor understands that they are becoming a co-permittee, along with the owner(s) and other contractors and subcontractors, to the Iowa Department of Natural Resources NPDES General Permit No. 2 for “Storm Water Discharge Associated with Industrial Activity for Construction Activities” at the identified site. As co-permittee, the contractor understands that they and their company are legally required under the Clean Water Act and the Code of Iowa, to ensure compliance with the terms and conditions of the Storm Pollution Prevention Plan developed under this NPDES permit and the terms of this NPDES permit.

12 METHOD OF MEASUREMENT

The Engineer will measure the items of work that have been acceptably constructed as specified in the contract documents for the Oak Park Blvd Sewer Replacement Project in accordance with the 2023 Edition of the SUDAS and as further modified by the Current City of Cedar Falls’ Supplemental Specifications of the SUDAS Statewide Urban Design and Specifications Program and the special provisions included in the contract documents.

13 BASIS OF PAYMENT

Payment for the items listed in the Method of Measurement shall be determined by multiplying the item quantity (as determined in the Method of Measurement) by the unit price as bid on the proposal form in accordance with the 2023 Edition of the SUDAS and as further modified by the Current City of Cedar Falls’ Supplemental Specifications to SUDAS.

DIVISION 3

STANDARD SPECIFICATIONS

The City of Cedar Falls has adopted the 2023 Edition of the STATEWIDE URBAN STANDARD SPECIFICATIONS FOR PUBLIC IMPROVEMENTS (SUDAS) as the City's Standard Specification.

This Standard Specification is amended by the "City of Cedar Falls" Current Supplemental Specifications to SUDAS.

Links to both documents can be found on the City's website at:
www.cedarfalls.com/designstandards

DIVISION 4

SUPPLEMENTAL PLANS AND SPECIFICATIONS

All work shall be constructed as specified in the Contract documents for the Oak Park Blvd Sewer Replacement Project in accordance with the 2023 Edition of the SUDAS as amended by the City of Cedar Falls' Current Supplemental Specifications to t SUDAS, except as amended or supplemented as follows:

Division 2 – Earthwork

Part 3 – Execution

ADD 3.10 STRUCTURE REMOVALS

1. Contractor to remove the existing aerial sanitary sewer crossing structure located between Oak Park Blvd. and Minnetonka Dr. Structure removal includes, but is not limited to, the removal of concrete footings, truss beam, wooden beam, and protective tarp.
2. Aerial structure footings shall be removed no deeper than one (1) foot below the existing ground elevation.
3. Contractor to haul and dispose of aerial crossing structure after removal. Disposal shall be in accordance with all rules and regulations set forth by the City of Cedar Falls and the State of Iowa.

Division 3 – Trench Excavation and Backfill

SECTION 3010: Trench Excavation and Backfill

MODIFY Part 1 – General as follows:

1.03 SUBMITTALS

- C. Submit a dewatering operation plan including methods and discharge points. Select suitable discharge locations to prevent damage or flooding of private or public property. Submit a dewatering plan to the Engineer for review prior to construction.
- D. Submit a trench sheeting, shoring, and bracing plan prepared by a licensed Professional Engineer in the State of Iowa for excavations greater than twenty (20) feet in depth. Submission shall include a drawing indicating materials and dimensions of the sheeting, shoring, and bracing materials as well as a plan and cross section view of the excavation which the sheeting, shoring, and bracing is necessary.

ADD Part 1 – General as follows:

1.07 SPECIAL REQUIREMENTS

A. Construction site dewatering may require a variety of permits depending on dewatering methods. The Contractor is responsible for obtaining all permits necessary to dewater the construction site prior to the beginning of these operations (including fee payments). The Contractor shall be fully liable for all fines applied to the project for not acquiring proper permits prior to construction or failure to meet the conditions of the permits set forth therein. The following is a partial list of permits and/or requirements that may be necessary:

1. Iowa DNR National Pollutant Discharge Elimination System (NPDES) General Permit No. 6 for well construction and well service discharges if discharge from well construction reaches waters of the United States of America.
2. Iowa DNR General Permit No. 9

1.08 MEASUREMENT AND PAYMENT

A. General

1. Hazardous waste disposal including, but not limited to, removal and disposal of all hazardous materials from the project site to comply with all local, state, and federal law. A waste is determined to be hazardous if it is specifically listed on one of four lists (F, K, P, and U) found in title 40 of the Code of Federal Regulations (CFR) in Section 261.

SECTION 3020: TRENCHLESS CONSTRUCTION

ADD Part 1 – General as follows:

1.03 SUBMITTALS

- E. Provide a contingency plan that includes actions that will be taken in case any surface subsidence, subsurface difficulties, above normal groundwater or surface water conditions, running sands, or solid rock (including bedrock) present themselves.
- F. Plan showing location and arrangement of the tunneling and receiving pits including details on pit construction that illustrate equipment used, installation methods, handling of excavated materials, backfilling of pits, and certified sheeting and shoring plan prepared by a licensed Professional Engineer in the State of Iowa if pit exceeds 20-feet in depth.

1.09 MEASUREMENT AND PAYMENT

No price adjustment or additional compensation will be made for variations in the rate of tunnel production, amount of dewatering, removal of rock (including bed rock), debris, cobbles, boulders, or other subterranean objects.

ADD Part 3 – Execution as follows:

3.04 TRENCHLESS INSTALLATION

- E. Should a solid rock face, debris, or boulder(s) be encountered the Contractor shall notify the

Engineer of the conditions encountered immediately.

Division 4 – Sewers and Drains

Section 4010 – Sanitary Sewers

MODIFY Part 1 – General as follows:

1.08 MEASUREMENT AND PAYMENT

A. Sanitary Sewer Gravity Main:

1. Trenched:

- c. **Includes:** Unit price includes, but is not limited to, furnishing and installing pipe; trench excavation, dewatering, furnishing bedding material, placing bedding and backfilling material, wyes, and other fittings, pipe joints, pipe connections, testing, **bypass pumping**, and inspection.

2. Trenchless:

- c. **Includes:** Unit price includes, but is not limited to, furnishing and installing pipe; trenchless installation materials and equipment, pit excavation, dewatering, and placing backfill material; pipe connections; **bypass pumping**; testing; and inspection.

C. Sanitary Sewer Force Main:

1. Trenched

- c. **Includes:** Unit price includes, but is not limited to, trench excavation; dewatering; furnishing and installing pipe; furnishing, placing, and compacting bedding and backfill; wyes and other fittings; **tracer wire and tracer wire stations installed at no greater distance than manufacturer's recommendations**; pipe joints; testing; and inspection.

2. Trenchless

- c. **Includes:** Unit price includes, but is not limited to, furnishing and installing pipe; trenchless installation materials and equipment; pit excavation; dewatering; placing and compacting backfill material; ; **tracer wire and tracer wire stations installed at no greater distance than manufacturer's recommendations**; pipe connections; testing; and inspection.

ADD 2.02 Sanitary Sewer Force Mains

F. High-Density Polyethylene Pipe (HDPE) $\frac{3}{4}$ in. to 3 in.:

1. **Material:** AWWA C901-17 or AWW C906-15
2. **Thickness:** SDR 13.5

3. **Joints:** Heat Fusion, Mechanical Joint Where Required
4. **Fittings:** Mechanical Joint as Required

G. Solid Wall Polyvinyl Chloride Pipe (PVC) Smaller than 4 in.:

1. **Material:** ASTM D-1785
2. **Thickness:** Sch 80
3. **Joints:** Solvent Weld
4. **Fittings:** Solvent Weld

REPLACE 2.02 Sanitary Sewer Force Mains - C. Sewage Air Release Valve

1. Scope

- i. This specification is intended to cover the design, manufacture, and testing of 1 in. (25 mm) through 8 in. (200 mm) Wastewater Combination Air Valves suitable for pressures up to 150 psig (1000 kPa).
- ii. Wastewater Combination Air Valves shall be automatic float operated valves designed to exhaust large quantities of air during the filling of a piping system and close upon liquid entry. The valve shall open during draining or if a negative pressure occurs. The valve shall also release accumulated air from a piping system while the system is in operation and under pressure. The valve shall perform the functions of both Wastewater Air Release and Wastewater Air/Vacuum Valves and furnished as a single body or dual body type as indicated on the plans.

2. Standards, Approvals and Verification

- i. Valves shall be manufactured and tested in accordance with American Water Works Association (AWWA) Standard C512.
- ii. Manufacturer shall have a quality management system that is certified to ISO 9001 by an accredited, certifying body.

3. Connections

- i. Single body valves sizes 4 in. (100 mm) and smaller shall have full size NPT inlets and outlets equal to the nominal valve size with a 2 in. (50 mm) inlet on 1 in. (25 mm) valves. The body inlet connections shall be hexagonal for a wrench connection. The body shall have 2" NPT cleanout and 1" NPT drain connection on the side of the casting.
- ii. Dual body valves sizes 3 in. (75 mm) and smaller shall have full size NPT inlets and outlets equal to the nominal valve size with a 2 in. (50 mm) inlet on 1 in. (25 mm) valves. The body inlet connection shall be hexagonal for a wrench connection. Valve sizes 4 in. (100 mm) through 6 in. (150mm) shall have bolted flanged inlets and NPT outlets. 8 in. (200 mm) valves shall have flanged inlets and outlets. Flanges shall be in accordance with ANSI B16.1 for Class 125 iron flanges.
- iii. The valve shall have three additional NPT connections for the addition of backwash accessories.

4. Design

- i. Both single and dual body valves shall provide an extended body with a through flow area equal to the nominal size. Floats shall be unconditionally guaranteed against failure including

pressure surges. A resilient bumper shall be provided on 4 in. (100 mm) and larger sizes to cushion the float during sudden opening conditions. The seat shall provide drop tight shut off to the full valve pressure rating.

- ii. Dual body valves shall consist of a Wastewater Air Release Valve piped to a Wastewater Air/Vacuum Valve with a full-ported brass ball valve.
 - a. The Wastewater Air Release Valve shall have an extended leverage mechanism with sufficient mechanical advantage so that the valve will open under full operating pressure. An adjustable threaded resilient orifice button shall be used to seal the precision discharge orifice in the cover.
 - b. The Wastewater Air/Vacuum Valve sizes 4 in. (100 mm) and larger shall have a cover fitted to the valve body by means of a machined register to maintain concentricity between the top and bottom guide bushings at all times. The tandem float assembly shall have a hexagonal guide shaft supported in the body by circular bushings to prevent binding from debris. The upper float shall be protected against direct water impact by an internal baffle. The seat shall be a minimum of .5 in. (12 mm) thick on 2 in. (50 mm) and larger valves and secured in such a manner as to prevent distortion.
- iii. Single body valves shall have a full port orifice, a double guided plug, and an adjustable threaded orifice button. The 1 in. (25 mm) body shall be globe style to increase float clearance and reduce clogging. The plug shall be protected against direct water impact by an internal baffle and an extended float stem. The plug shall have a precision orifice drilled through the center stem. The float shall include a sensitivity skirt to minimize spillage.

5. Materials

- i. The valve body and cover shall be constructed of ASTM A126 Class B cast iron.
- ii. The float, plug, guide shafts, and bushings shall be constructed of Type 316 stainless steel. Non-metallic guides and bushings are not acceptable. Resilient seats shall be Buna-N.

6. Options

- i. Backwash accessories shall be furnished when specified and shall consist of an inlet shut-off valve, a blow-off valve, a clean water inlet valve, rubber supply hose, and quick disconnect couplings. Accessory valves shall be quarter-turn, full ported bronze ball valves.
- ii. An optional Regulated Exhaust Device shall be provided when specified to reduce pressure surges due to column separation or rapid changes in velocity and pressure in the pipeline.
 - a. The Regulated Exhaust Device shall be mounted on the outlet of the Wastewater Combination Air Valve, allow free air flow in and out of the valve, close upon rapid air exhaust, and control the air exhaust rate to reduce pressure surges.
 - b. The device shall have a threaded or flanged globe-style body with a center guided disc and seat assembly. The disc shall have threaded holes to provide adjustment of the air exhaust rate through the valve. The holes shall provide for a flow area of 5% of the nominal valve size.
 - c. The material of the body shall be consistent with the Wastewater Combination Air Valve. The seat and disc shall be ASTM A351 Grade CF8M stainless steel.
- iii. Optional body materials include ASTM A536 Grade 65-45-12 ductile iron, ASTM A351 Grade CF8M stainless steel, and ASTM B584 Alloy 836 cast bronze.
- iv. Valve interiors and exteriors shall be coated with an NSF/ANSI 61 certified fusion bonded epoxy in accordance with AWWA C550 when specified.

- v. Low Durometer seat and orifice button shall be furnished for low pressure applications.

7. Manufacturer

- i. The manufacturer shall demonstrate a minimum of (5) years' experience in the manufacture of wastewater air valves. The valves shall be manufactured and tested in accordance with American Water Works Association Standard (AWWA) C512. When requested, the manufacturer shall provide test certificates, dimensional drawings, parts list drawings, and operation and maintenance manuals.
- ii. The exterior of the valve shall be coated with a universal alkyd primer.
- iii. Wastewater Combination Air Valves shall be Series 800 or 48A/300 as manufactured by Val-Matic Valve and Manufacturing Corporation, Elmhurst, IL, USA or approved equal.

ADD Part 3 – Execution as follows:

3.14 BYPASS PUMPING

Comply with bypass pumping per Section 4050 3.02.

Section 4050 – Pipe Rehabilitation

ADD 3.02 – Bypassing Sewage

- D. Contractor shall furnish, install and operate temporary sewage bypass conveyance methods at such times, locations, and durations as necessary to complete the work and maintain continuous flow of raw sewage.
- E. Contractor shall obtain Owner agreement on means and methods to ensure continuous sewage conveyance without causing backup, and operations and emergency response. Contractor remains solely responsible for means and methods.
- F. Contractor shall be available 24 hours a day, 7 days a week during bypass conveyance to ensure sewage backup will not occur. Provide temporary failure/backup alarm system. Provide personnel and response equipment within a maximum 20 minute response time.
- G. Provide multiple pumps. If more than one pump is used at a bypass connection, contractor shall provide above-grade temporary discharge header as needed. A minimum of one pump shall be provided at each bypass pump connection.

END OF SECTION

SECTION 33 32 16
PACKAGED UTILITY WASTEWATER PUMPING STATIONS

PART 1- GENERAL

1.01 - DESCRIPTION

- A. This section includes furnishing and installing a duplex submersible centrifugal sewage grinder pump station with remote mounted control panel for pumping raw sewage.
- B. The pumping system shall be provided to the jobsite complete with all controls, accessories and other appurtenances as specified and as required for a complete operating installation.

1.02 – SUBMITTALS

- A. Shop drawings: complete fabrication and installation drawings; including layout, dimensions, component dimensions, weights, details, installation information necessary to show compliance with specifications, and recommended installation procedures.
- B. Engineering calculations: as necessary to show compliance with the specifications.
- C. Maintenance and operation instructions.
 - 1. Submit three copies of manufacturer's maintenance and operation instructions.
 - 2. Include parts list and lubrication instructions.

1.03 – PRODUCT DELIVERY, STORAGE AND HANDLING

- A. Deliver equipment in manufacturer's original unopened protective packaging or skids.
- B. Cover and store equipment above ground so as to keep free from water or other deteriorating elements.
- C. Handle carefully to prevent equipment damage during installation.

1.04 – QUALITY ASSURANCE

- A. The manufacturer shall provide evidence of satisfactory performance on a minimum of ten (10) similar projects of equal service conditions for a minimum period of five (5) years in the United States. Submit past project lists with Owner contact name/phone number data.

1.06 – OPERATION AND MAINTENANCE MANUALS

- A. Submit operations and maintenance manuals for the equipment in compliance with the Contract documents, prior to shipment. Manuals shall include:
 - 1. Name, address, and telephone number of the nearest competent service representative who can furnish parts and technical service.
 - 2. Descriptive literature, including illustrations, covering the operational features of the equipment, specific for the particular installation, with all inapplicable information omitted or marked out.
 - 3. Operating, maintenance and troubleshooting information.
 - 4. Complete maintenance parts list.

5. Complete connection, interconnecting and assembly diagrams.
6. Approved shop drawings including complete electrical information.

1.07 – QUALITY ASSURANCE

- A. The manufacturer shall provide evidence of satisfactory performance on a minimum of ten (10) similar projects of equal service conditions for a minimum period of five (5) years in the United States. Submit past projects list with the Owner contact name/phone number data.

1.08 – APPROVED MANUFACTURERS

- A. All of the following equipment will be supplied by single provider.
- B. Pumps: HPGHHX-750 as manufactured by Pentair Hydromatic.
- C. Fiberglass Basin: Topps Industries as supplied by Allied Systems, Inc. 2200 E. Douglas Ave Des Moines, IA 50313.
- D. Control Panel: Alderon Industries, Hawley, MN
- E. Other products or substitutions require pre-approval by Engineer. No substitutions.

PART 2 - PRODUCTS

2.01 PRESSURE SEWER GRINDER PACKAGE LIFT STATION

- A. Two submersible centrifugal submersible grinder pumps designed to reduce all material found in normal domestic sewage, including plastics, rubber, sanitary napkins, and disposable diapers into a finely ground slurry shall be provided.
- B. The resultant slurry is then pumped through small diameter piping, gravity interceptor, or treatment facility. The temperature limitation of the liquid being pumped is 104°F (40°C) continuous.
- C. Contractor shall furnish all labor, materials, equipment, and incidentals required to provide one duplex submersible centrifugal sewage grinder pump(s) as specified herein.

D. OPERATION CONDITIONS

1. Each pump shall be rated 7.5 hp, 230 volts, 60Hz, 3 phase, and 3450 rpm. The unit shall produce 43 U.S. GPM at 103 feet TDH.

E. CONSTRUCTION

1. Each pump shall be a sealed submersible type, model HPGHHX-750 manufactured by Pentair Hydromatic. The pump volute, motor, and seal housing shall be high-quality gray cast iron, ASTM A-48, Class 30. All external mating parts shall be machined and Nitrile O-ring sealed on a beveled edge. Gaskets shall not be acceptable. All fasteners exposed to the pumped liquids shall be 300 series stainless steel.

F. ELECTRICAL POWER CORD

1. Electrical power cord shall be SOOW or W, water-resistant 600V, 90°C, UL and/or CSA approved and applied dependent on amp draw for size.
2. The power cable entry into the cord cap assembly shall first be made with a compression fitting. Each individual lead shall be stripped down to bare wire, at staggered intervals, and each strand shall be individually separated. This area of the cord cap shall then be fitted with an epoxy compound potting which will prevent water contamination to gain entry even in the event of wicking or capillary attraction.
3. The power cord leads shall then be connected to the motor leads with extra heavy connectors having brass inserts with a screwed wire-to-wire connection.

G. MOTOR

1. The stator, rotor, and bearings shall be mounted in a sealed submersible type housing. The stator windings shall have Class F insulation (155°C or 311°F) and a dielectric oil-filled motor, NEMA B design (three-phase), NEMA L design (single-phase).
2. The pump and motor shall be specifically designed so that they may be operated partially dry or completely submerged in the liquid being pumped.
3. Stators shall be securely held in place with a removable end ring and threaded fasteners. No special tools shall be required for pump and motor disassembly.
4. Pump shall be equipped with heat sensors. The heat sensor(s) (one on single-phase, two on three-phase) shall be a low resistance, bimetal disc that is temperature sensitive. It (they) shall be mounted directly in the stator and sized to open at 120°C or 130°C and automatically reset at 30–35°C differential. The sensor shall be connected in series with the motor starter coil so that the starter is tripped if a heat sensor opens. The motor starter shall be equipped with overload heaters so all normal overloads are protected by an external heater block.

H. BEARINGS AND SHAFT

1. An upper radial bearing and a lower thrust bearing shall be required. These shall be permanently lubricated by the dielectric oil that fills the motor housing.
2. The shaft shall be machined from a solid 416 stainless steel and be a design that is of large diameter with minimum overhand to reduce shaft deflection and prolong bearing life.

I. SEALS AND SENSORS

1. The rotor and stator in the motor housing shall be separated and protected from the pumped liquid by an oil-filled seal housing incorporating two type 21 carbon ceramic mechanical seals mounted in tandem. This seal housing shall be equipped with 2 moisture sensing probes installed between the seals, and the sensing of moisture in the seal chamber shall be automatic, continuous, and not require the pump be stopped or removed from the wet well.

J. IMPELLERS

1. Impeller shall be 316 stainless steel multivane, semi-open, non-overloading design. They can either be factory or field trimmed to meet specific performance conditions. Impellers shall be dynamically balanced at the factory and machined for threading on to the pump shaft.

K. GRINDER CUTTERS

1. The combination centrifugal pump impeller and grinder unit shall be attached to the common motor and pump shaft made of 416 stainless steel. The grinder unit shall be on the suction side of the pump impeller and discharge directly into the impeller inlet, leaving no exposed shaft to permit packing of ground solids. The grinder shall consist of two stages. The cutting action of the second stage shall be perpendicular to the plane of the first cut for better control of the particle size. The grinder shall be capable of grinding normal domestic sewage. Both stationary and rotating cutters shall be made of 440C stainless steel hardened to Rockwell 60C and ground to close tolerance.
2. The upper (axial) cutter and stationary cutter ring shall be reversible to provide new cutting edges to double life. The stationary cutter ring shall be a slip fit into the suction opening of the volute and held in place by three (3) 300 series stainless steel screws and a retaining ring. The lower (radial) cutter shall macerate the solids against the I.D. of the cutter ring and extrude them through the slots of the cutter ring. The upper (axial) cutter shall cut off the extrusions, as they emerge from the slots of the cutter ring to eliminate any roping effect that may occur in single stage cutting action. The upper (axial) cutter shall fit over the hub of the impeller and the lower (radial) cutter shall be slip fit and secured by means of peg and hole and rotate simultaneously with the rotation of the shaft and impeller. The grinding mechanism shall be locked to the shaft by a 300 series stainless steel countersunk washer in conjunction with a 300 series stainless steel flat head cap screw threaded into the end of the shaft.

L. TESTING

1. Commercial testing shall be required and include the following:
 - a. The pump shall be visually inspected to confirm that it is built in accordance with the specification as to HP, voltage, phase and hertz.
 - b. The motor and seal housing chambers shall be hi-potted to test for moisture content and/or insulation defects.
2. Pump shall be allowed to run dry to check for proper rotation.
3. Discharge piping shall be attached, the pump submerged in water and amp readings shall be taken in each leg to check for an unbalanced stator winding. If there is a significant difference in readings, the stator windings shall be checked with a bridge to determine if an unbalanced resistance exists. If so, the stator will be replaced.

M. PAINT

1. The pump shall be painted with waterborne hybrid acrylic/alkyd paint. This custom engineered, quick dry paint shall provide superior levels of corrosion and chemical protection.

2.03 – FRP BASIN

- A. Contractor shall furnish all labor, materials, equipment and performance of all work necessary or incidental to furnish and install a duplex prefabricated fiberglass reinforced polyester (FRP) Lift station. The lift station shall be completely factory-assembled unit, requiring minor adjustments and reassembly on site.

- B. Basis of bids is Topps Industries, or pre-approved equal.

C. Basin

1. FRP Materials shall be a Vinyl Ester Fiberglass Laminate consisting of a chop spray interior liner that protects the chop hoop filament wound structural exterior. The inner surface shall have a resin rich inner surface free of cracks and with smooth finish with no more than two pits per square foot (average) providing pits are less than 0.125 inches in diameter and 0.3125 inches in depth.
2. The Basin shall have a fiberglass encased steel anti floatation ring.
3. A concrete collar is required on and around the anti-floatation ring.
4. The top of the basin will have an aluminum cover with hatches for pumps and access to valve vault.
5. The top cover shall be fitted with a mushroom vent cap with insect screen.

D. Discharge Piping

1. The pumps shall be fitted to a cast iron base elbow and sealing flange. Discharge shall be 3".
2. Discharge piping: 3" diameter Sch 80 PVC inside the basin.
3. There shall be two 3" Plug Valves w/handle constructed of stainless steel with handwheel shall be installed for isolating a line for servicing of pump or check valve.
4. There shall be two 3" Swing Check Valves constructed of stainless steel to prevent back flow to non operating pump(s).
5. Link seals shall be included for piping passing through basin walls that separate the pump well and valve vault as well as discharge of the valve vault.

E. Lifting System

1. The pumps will have a lifting bail and lifting cable capable of at least twice the weight of the pumps. Bail and cable shall be 304SS.

F. Accessories

1. The pump well shall include a composite electrical hub, 2 inch.
2. The inlet to pump well shall be an 8" composite hub for PVC pipe. Field caulking will be required.

2.04 – MOTOR CONTROL PANEL (FURNISHED BY OWNER INSTALLED BY CONTRACTOR)

- A. Furnish one Duplex Control Panel to operate two pump motors and auxiliary accessories for manual or automatic operation. The panel enclosure will be Nema 3R equipped with a 3 point padlockable handle. The enclosure will be stainless steel. The sub panel shall be painted white.
- B. The control system will operate on 230 volts, 60 hertz, single phase power supply. Pump control components shall be sized to operate pump motors of 7.5 horsepower with 21 FLA at proper RPM. VFDs shall be used for phase conversion to 3/60/230 volt.
- C. The Control Panel shall include the following components for operating two pump motors.
 1. Motor Circuit Breakers which provides disconnect and over current protection. The disconnect will be operable through the door and be interlocked with the door such that the door cannot be opened when the disconnect is in the on position.
 2. Variable Frequency Drives sized to the motor horsepower. The drives shall convert single phase input to three phase output to operate the pump motors. The VFDs shall be Toshiba S15 UF S1F-20175 PM W1.
 3. The panel shall include Controls to control operation of the pumps. Control will only permit operation of one pump at any time.
 4. Float level control shall operate the pumps.
 5. Indicator lights for Pump On and Seal Fail indication. Indicator lights shall be heavy duty oil tight rated for Nema class of enclosure.
 6. Elapsed Timer meters for each pump. Meters will measure hours of operation be heavy duty and rated for the Nema 1 class of the enclosure.
 7. Terminal strip to provide ease in connection of external components.
 8. Float level control system comprised of five (5) float switches and cord holding bracket.
- D. Condensate heater shall be included to maintain > 50F internal panel temperature. The duplex float system is designed to start a pump on an increase in liquid level as sensed by level controller. The pump continues to run until it is no longer needed, as sensed by the level controller. If the level continues to rise the level controller or High Float switch, a high-level indicator alarm circuit will be energized.
- E. In the event of a pump malfunction due to motor overload tripping, the other pump will be started automatically by the transformer-switching relay.
- F. Alternation of pumps will be automated via alternator relay with selector switch to indicate Pump 1 lead or Pump 2 lead or Alternation of Pump 1 and 2.

- G. Panel shall also include a top mounted high alarm-flashing indicator light in protected housing along with alarm horn with push to silence/acknowledge alarm condition.
- H. The Panel will be mounted on 18" high base stand, which the contractor shall anchor to concrete base.
- I. The control shall include the following features and components.

Enclosure, Steel, Saginaw, 72"X36"X24", 3 PT Padlockable Latch
Steel, Saginaw Mounting Feet 18"H x 24"D
Inner Deadfront Door
3R Fan PF 65000 R P/N - 11665153115 - no hoods required
3R PF 65000 R "A" Reversing Fan P/N - 11665153116 - no hoods required
Cooling Fan Thermostat, Overcurrent Protection
Saginaw, 125 Watt Thermostat Anti Condensation Heater w/ Overcurrent Protection
Under Voltage Relay
1 Phase Surge Capacitor
1 Phase Lighting Arrestor
Main/Generator Circuit Breakers - Mechanical Interlock - SERVICE ENTRANCE RATED
Reverse Service Generator Receptacle – Crouse Hinds Model APJ6485SS55 cord mounted shipped loose
Control & Alarm Circuit Breakers
Heavy Duty 22mm HOA Switch
Heavy Duty 22mm Pump Run Indicator - Green
Seal Fail Relay w/ Heavy Duty Indicator
Thermal Cutout Circuit w/ Heavy Duty Indicator

15 Amp GFI Convenience Receptacle w/Overcurrent protection
Pump Cycle & Elapsed Time Meter
Pump/Motor Fused Disconnect Switch With Interlock Handle, Class J Fuses
VFD Fusing
Toshiba VFD's - VFS15-2110PM-W1
Customer Supplied Telemetry and UPS Zetron radio
Steady On - Ingram SunBurst 120VAC Led Alarm Light - Red
Normally Open Push Button 22mm - Silence, Alarm Reset
The Sounder Ingram Buzzer, 4"X4" Square, Red
Alarm Dry Contacts - High Level, Low Level, Seal Fail 1, Seal Fail 2, Pump 1 Run, Pump 2 Run
5 Float Intrinsically Safe Float Circuits With Barrier(s)
Crouzet Alternating Smart Relay, 16I/10O, With Pump & Alarm History - In Generator mode only run 1 VFD at a time.
22mm Selector Switch - Single pump per cycle or Duplex Lead and Lag
30' Weighted Mechanical Float Switches

Required Terminal Blocks/Control Relays/Wire Duct
Ground Bar, 9 Space 14-10 AWG
UL Label -698A - Intrinsically Safe

2.06 – REMOTE TELEMETRY UNIT

1. The City will supply a Zetron branded RTU for mounting and wiring by the control manufacturer.

PART 3 - EXECUTION

3.01 – INSTALLATION

- A. Install equipment in accordance with manufacturer's recommendations and as shown on plans.
- B. Test pumps as specified.
- C. Manufacturer's representative to inspect installation and witness pump and VFD tests as specified.

3.02 PUMP TEST: The pump manufacturer shall perform the following inspections and tests:

1. A check of the motor voltage and frequency shall be made as shown on the name plate.
 2. A motor and cable insulation test for moisture content or insulation defects shall be made per CSA criteria.
 3. The pump shall be completely submerged and run to determine that the unit meets three pre-determined hydraulic performance points.
- B. START-UP: The pump (s) shall be tested at start-up by a qualified representative of the manufacturer. A start-up report as provided by the manufacturer shall be completed before final acceptance of the pump (s).

- C. DOCUMENTATION: The manufacturer, if requested, will supply a minimum of three (3) sets of standard submittal data; Standard submittal data consist of:
1. Pump catalog data
 2. Pump performance curve
 3. Break Away Fitting (BAF) data
 4. Cover data
 5. Typical installation drawing
 6. Control panel data
 7. Panel wiring schematic
 8. Accessory data
 9. Installation & Operation Manuals with Parts List

3.03 – FIELD TESTS

- A. Subject each pump to 8 hours operation field test on-off (50% run time) before pump station start-up.
- B. Preparation: install each pump in operating position; check for proper service voltage and impeller rotation.
- C. Dry pumping test: operate each pump with maximum 2 foot of water above centerline of pump volute for 60 minutes continuously with pump connected to discharge piping.
- D. No external liquid or air source permitted for cooling pump or motor.
- E. Manufacturer's representative and Engineer must be present during dry pumping test.
- F. Pumps subject to rejection by Engineer for excessive noise, vibration, heat or seizing; replace rejected pump and repeat tests until pump is accepted.

3.04 – START-UP AND ADJUSTMENT

- A. Contractor shall be responsible for start-up and check-out of control system with control system supplier as required to fine tune system in order to assure that a complete and efficiently working system is turned over to the Owner.
- B. System check-out shall be in presence of Engineer to verify proper operation of system.
- C. The installation of equipment shall be inspected by supplier to validate warranty

END OF SECTION 33 32 16

DIVISION 5
GEOTECHNICAL ENGINEERING REPORT



Geotechnical Engineering Report

**Sanitary Sewer Ravine Crossing
Cedar Falls, Iowa**

May 9, 2019

Terracon Project No. 13185123.02

Prepared for:

Snyder & Associates, Inc.
Cedar Rapids, Iowa

Prepared by:

Terracon Consultants, Inc.
Cedar Falls, Iowa



May 9, 2019



Snyder & Associates, Inc.
5005 Bowling Street SW, Suite A
Cedar Rapids, Iowa 52404

Attn: Mr. Patrick Schwickerath, P.E.
P: (319) 362-9394
E: pschwickerath@snyder-associates.com

Re: Geotechnical Engineering Report
Sanitary Sewer Ravine Crossing
Minnetonka Drive and Oak Park Boulevard
Cedar Falls, Iowa
Terracon Project No. 13185123.02

Dear Mr. Schwickerath:

Terracon Consultants, Inc. (Terracon) has performed geotechnical engineering services for the above referenced project. Terracon's services were performed in general accordance with Terracon Proposal No. P13185123 dated February 6, 2019. This report presents the findings of the subsurface exploration and provides geotechnical recommendations concerning design and construction of foundations for a new sewer and includes the stability analyses of slopes with the support structure for the proposed project. This report replaces our original geotechnical engineering report (Terracon Project No. 13185123) dated April 17, 2019.

We appreciate the opportunity to be of service to you on this project. If you have any questions concerning this report or if we may be of further service, please contact us.

Sincerely,
Terracon Consultants, Inc.

Deep K. Khatri, Ph.D., P.E. (TX)
Sr. Staff Engineer

Jason P. Heinz, P.E.
Iowa No. 18345

Copies to: Addressee (PDF)

REPORT TOPICS

INTRODUCTION..... 1

PROJECT INFORMATION 2

GEOTECHNICAL CHARACTERIZATION..... 3

GEOTECHNICAL OVERVIEW 5

EARTHWORK..... 5

SHALLOW FOUNDATIONS 7

DEEP FOUNDATIONS 9

SEISMIC CONSIDERATIONS 10

LATERAL EARTH PRESSURES 10

SLOPE STABILITY..... 12

GENERAL COMMENTS..... 15

ATTACHMENTS..... 17

ATTACHMENTS

- EXPLORATION AND TESTING PROCEDURES**
- SITE LOCATION AND EXPLORATION PLANS**
- EXPLORATION RESULTS**
- SUPPORTING INFORMATION**

Geotechnical Engineering Report
Sanitary Sewer Ravine Crossing
Minnetonka Drive and Oak Park Boulevard
Cedar Falls, Iowa
Terracon Project No. 13185123.02
May 9, 2019

INTRODUCTION

This report presents the results of our subsurface exploration and geotechnical engineering services performed for a sanitary sewer ravine crossing located at Minnetonka Drive and Oak Park Boulevard in Cedar Falls, Iowa. The purpose of these services is to provide information and geotechnical engineering recommendations relative to:

- Subsurface soil conditions
- Groundwater conditions
- Earthwork
- Foundation design and construction
- Stability of the ravine slopes
- Remedial measures for the slope failure
- Seismic site classification per IBC

The geotechnical engineering Scope of Services for this project included the advancement of two soil borings to depths of about 50 feet below existing grades. Maps showing the site and boring locations are shown in the attached **Site Location and Exploration Plans**. The results of laboratory testing performed on portions of soil samples obtained from the borings are included on the boring logs and as separate graphs in the attached **Exploration Results**.

PROJECT INFORMATION

Item	Description
Location	The project site is located at the ravine between Minnetonka Drive and Oak Park Boulevard in Cedar Falls, Iowa. See Site Location
Existing improvements	A sanitary sewer and its support structure are present across the ravine. A manhole is also present near the crest of the west ravine slope.
Current ground cover	Lawns, various vegetation, trees, and some surface fill (cobbles/boulders) are present at the surface of the site.
Existing Topography	Based on the contours illustrated on the <i>Existing Features</i> drawing dated March 25, 2019, provided by Snyder & Associates via email, it appears that about 30 to 35 feet of elevation difference exists between the crests and toes of the ravine slopes. Locally, slope inclinations appear to vary from near vertical in the area of the failure to about 2.5 Horizontal to 1 Vertical (2.5H:1V).
Slope Failure	The west ravine slope failed at the toe of the slope. Based on our field observation, the sanitary sewer support structure at the west slope, which consists of a rectangular concrete section with embedded steel section, also failed. The entire length of the footing/pier support is exposed and appeared to be embedded about several feet below the original grade near the middle portion of the west slope height. The scarp in the slope is shown in Figure1 below.
General Project Description	The project consists of the replacement of a section of the aerial sanitary sewer that crosses a ravine in a residential area of Cedar Falls.
Structure Construction	A steel casing for a sanitary main is planned to be constructed across the ravine.
Preliminary Foundation Loads	<ul style="list-style-type: none"> ■ 2-span concept, 160-foot total length across ravine <ul style="list-style-type: none"> · Abutments: 70 kips · Center Pier: 110 kips



Figure 1 - West ravine slope failure with scarp marked in red

GEOTECHNICAL CHARACTERIZATION

Subsurface Profile

We have developed a general characterization of the soil and groundwater conditions based upon our review of the subsurface exploration, laboratory data, geologic setting and our understanding of the project. This characterization forms the basis for our geotechnical calculations and evaluations of foundation options and ravine slope stability. Conditions encountered at each boring location are indicated on the individual boring logs in the attached **Exploration Results** section. Subsurface conditions can be generalized as follows.

Geotechnical Engineering Report

Sanitary Sewer Ravine Crossing ■ Cedar Falls, Iowa

May 9, 2019 ■ Terracon Project No. 13185123.02

Stratum	Description
Topsoil / Existing Fill	Extended to about 2.5 to 4 feet below existing grades
1	Lean Clay, with sand, and Sandy Lean Clay, trace gravel, stiff
2	Sandy lean clay, trace gravel with occasional sand and silt seams and layers, very stiff to hard

Groundwater Conditions

The boreholes were observed while drilling and after completion for the presence and level of groundwater. The water levels observed in the boreholes are provided on the boring logs in **Exploration Results**, and are summarized below.

Boring No.	Approximate Depth to Groundwater while Drilling (feet) ¹	Approximate Depth to Groundwater after Drilling (feet) ¹
1	14	---
2	16	None

1. Below ground surface

Due to the presence of fine-grained soils, a relatively long period is necessary for a groundwater level to develop and stabilize in a borehole. Long term monitoring in cased holes or piezometers would be required for a better evaluation of groundwater conditions and seasonal fluctuations. Groundwater level fluctuations occur due to seasonal variations in the amount of rainfall, runoff, and other factors not evident at the time the borings were performed. Therefore, groundwater levels during construction or at other times during the life of the structure may vary from than the levels indicated on the boring logs. In addition, perched water can develop within more 'permeable' sand and silt soils within and/or above less 'permeable' fine-grained soils. The possibility of groundwater level fluctuations and development of perched water conditions should be considered when developing the design and construction plans for the project.

GEOTECHNICAL OVERVIEW

The borings performed near the crests of both ravine slopes encountered relatively uniform soil profiles with stiff glacial deposits to about 10 feet depth below existing grades overlying very stiff to hard glacial till. The steel casing structure will be constructed to span across the ravine and support the new section of sanitary sewer. The loads from this structure system can be supported by a shallow foundation, bearing on native, stiff clay soils near the slope crests. The **Shallow Foundations** section provides the design and construction considerations for spread footing foundations. Helical pier foundations are discussed in the **Deep Foundations** section.

It is our opinion that the ravine slope failure at the toe occurred because of the relatively steep inclination of the slope and high phreatic surface. We recommend flattening and armoring of a portion of the west slope toe to reduce the amount of further ground loss, as indicated in the **Slope Remediation Measures** subsection of the **Slope Stability** section.

Site preparation recommendations including excavation and fill placement for the spread footing foundation construction are provided in the **Earthwork** section. The **General Comments** section provides comments regarding the limitations of this report.

EARTHWORK

Site Preparation

Vegetation, topsoil, organic materials, and any loose, soft, or otherwise unsuitable materials should be removed from planned foundation construction areas. The debris from the failure at the west slope toe should be removed. Debris removal from the west slope should be performed as indicated in **Slope Remediation Measures** subsection of the **Slope Stability** section. Special care should be taken so as not to disturb native soil below the debris.

Fill Material Types

Fill below and adjacent to foundations should meet the following material property requirements.

Fill Type ¹	USCS Classification	Acceptable Location for Placement
Imported, Low-plasticity, Fine-grained soil	CL, CL/SC (LL ≤ 45 and 10 ≤ PI ≤ 23) ²	Below and adjacent to foundations
Imported, Coarse-grained/Granular Fill ³	SP, SW, GW, GP	Below foundations > 2 feet below finished grade adjacent to foundations
On-site soil ⁴	CL, CL/SC	Below and adjacent to foundations

1. Fill below foundations should consist of approved materials that are free of organic matter or debris. Frozen material should not be used, and fill should not be placed on a frozen subgrade. Each proposed fill material should be sampled and evaluated by the geotechnical engineer prior to its delivery and/or use.
2. LL = Liquid Limit, PI = Plasticity Index.
3. Well-graded, free-draining granular material. A general gradation should be 100% passing the 1½-inch sieve, about 40 percent passing the No. 10 sieve, and less than 6 percent fines.
4. Moisture conditioning (i.e., drying) should be expected to achieve compaction requirements.

Fill Placement and Compaction Requirements

Fill should be placed and compacted in accordance with the following requirements.

Item	Structural Fill
Maximum Lift Thickness	4 to 6 inches in loose thickness for hand-operated equipment (i.e. jumping jack or plate compactor)
Minimum Compaction Requirements ^{1, 2}	98% of the material's maximum dry density value
Water Content Range from Optimum	Low plasticity, fine-grained: -2% to +3% Coarse-grained/Granular: Workable moisture levels ^{2, 3}

1. Maximum density and optimum water content as determined by the 'standard Proctor' test (ASTM D 698).
2. If the granular material is a coarse sand or gravel, or of a uniform size, or has a low fines content, compaction comparison to relative density may be more appropriate. In this case, granular materials should be compacted to at least 70% relative density (ASTM D 4253 and D 4254).
3. Specifically, moisture levels should be maintained low enough to allow for satisfactory compaction to be achieved without the granular fill material bulking during placement.

Terracon should be retained to monitor fill placement and to perform field density tests in order to assure compliance with the design requirements.

SHALLOW FOUNDATIONS

If the site has been prepared in accordance with the requirements in the **Earthwork** section and this section, the following design parameters are applicable for shallow foundations.

Design Parameters – Compressive Loads

Item	Description
Maximum Net Allowable Bearing pressure ^{1, 2, 3}	2,500 psf
Required Bearing Stratum ³	Stiff or very stiff native clay
Expected Bearing Depth	About 9 to 10 feet below grade
Minimum Footing Widths ²	30 inches
Estimated Total Settlement ²	1 inch or less
Estimated Differential Settlement ²	½ to ⅔ of the total settlement
Ultimate Passive Resistance ⁴	See Lateral Earth Pressures
Ultimate Coefficient of Sliding Friction ⁵	0.32 (native clay)
Minimum Embedment Depth below Finished Grades for Frost Protection ⁶	60 inches

1. The maximum net allowable bearing pressure is the pressure in excess of the minimum surrounding overburden pressure at the footing base elevation. An appropriate factor of safety has been applied.
2. Values provided are for maximum loads noted in **Project Description**. A 4-foot wide strip load was applied in the slope stability analyses.
3. Assumes all unsuitable soils or disturbed materials will be removed and replaced per the recommendations presented in the **Earthwork** section.
4. Use of passive earth pressures requires the sides of the excavation for the spread footing foundation to be nearly vertical and the concrete placed neat against these vertical faces or that the footing forms be removed and properly compacted fill be placed against the vertical footing face.
5. Can be used to compute sliding resistance where foundations are placed on suitable soil/materials.
6. A minimum embedment of 5 feet from surrounding grades to the bottom of the footing is recommended to prevent frost effects. For sloping ground, maintain depth below the lowest surrounding grade within 5 horizontal feet of the footing.

Foundation Construction Considerations

The footing excavations should be observed and evaluated by Terracon personnel prior to the placement of any fill, installation of formwork and reinforcing steel, and concrete. The base of foundation excavations should be free of water and disturbed/loose soil/material prior to placing concrete. Concrete should be placed soon after excavating to reduce the potential for bearing soil disturbance. Any water that collects within a foundation excavation should be promptly removed. If the bearing soil/material freezes, desiccates, saturates, or is disturbed, the affected material should be removed, prior to the placement of foundation concrete.

If unsuitable bearing soils are encountered at the base of a footing excavation, the excavation should be extended deeper to suitable soil, and the footings could bear directly on the suitable soil at the lower level or on lean concrete backfill extended to suitable soil, as illustrated in the following *Lean Concrete Backfill* figure. If compacted fill will be placed to support a footing, the excavation should be widened at least 8 inches beyond each footing edge for every foot of new fill placed below the design footing level, as illustrated in the following *Overexcavation / Backfill* figure. The overexcavation, from the recommended excavation level to the design footing level, should then be backfilled with an approved material as recommended in **Earthwork** section.

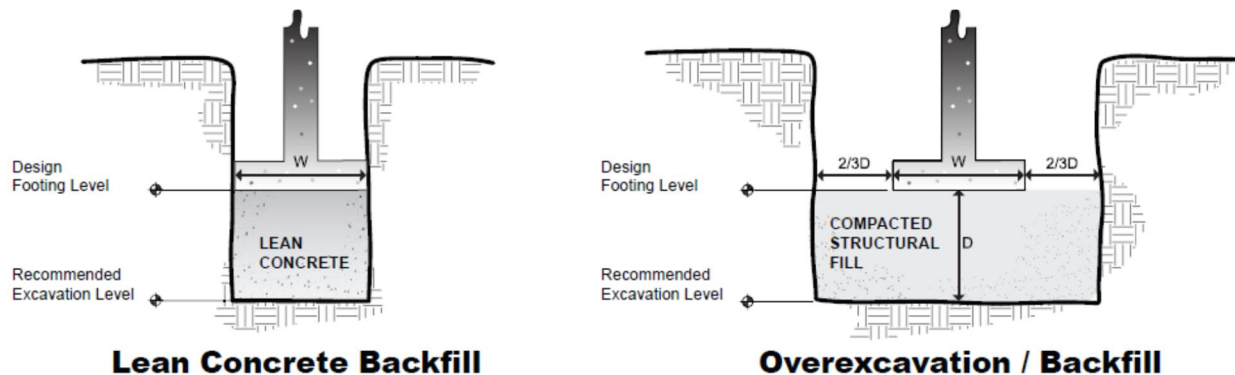

Note: Side walls are shown vertical for ease of dimensioning. In the field, side walls should be sloped or braced as required by OSHA.

As a minimum, excavations should be performed in accordance with OSHA 29 CFR, Part 1926, Subpart P, "Excavations" and its appendices, and in accordance with any applicable local, and/or state regulations. Construction site safety is the sole responsibility of the contractor who controls the means, methods, and sequencing of construction operations. Under no circumstances shall the information provided herein be interpreted to mean Terracon is assuming responsibility for construction site safety, or the contractor's activities; such responsibility shall neither be implied nor inferred.

DEEP FOUNDATIONS

Helical Pier Foundations

In our opinion, augered-in-place helical piers can be used to support the sanitary sewer support structure. Helical piers consist of steel rods with attached helical plates that are designed to reduce disturbance of the in-place soils. The piers are rotated into the ground to a pre-determined depth. Typically, the torque required to install the piers is measured and is used to evaluate the pier capacity.

Helical piers are proprietary systems designed by licensed contractors, based on their interpretation of the results of our subsurface exploration and laboratory testing and loads provided by the project structural engineer. We recommend that a performance specification be developed regarding allowable capacities and tolerable total and differential settlement. Upon request, Terracon can provide contact information for specialty contractors who provide these services.

Piers caps should be placed at a depth of 5 feet below final surrounding grades for frost protection. Shallower depths can be considered if movements related to frost heave are acceptable. Alternately, the provision of a void form could be considered below the pier cap.

Based on the anticipated structural loads and subsurface conditions described herein, post-construction settlements of helical piers that bear within very stiff to hard soils should be no more than 1 inch, but subject to design by others. Differential settlements can typically be on the order of ½ of the total settlement.

Construction Considerations for Helical Pier Foundations

Although not encountered in the borings performed for this project, it is our experience that the glacial clay soils in the general site vicinity can contain cobbles and boulders. If encountered during helical pier installation, these materials could impede penetration of the element, and a replacement element could be required. The foundation designer(s) should be consulted if an element encounters refusal shallower than its design depth.

Construction of the pier cap in the ravine will require provisions for surface water diversion and some dewatering. Based on the results of the borings, it appears that predominantly clay soils are present, and the use of pits and sump pumps should therefore be sufficient to facilitate construction 'in the dry'. Surface water diversion and groundwater removal should be planned in advance of construction.

SEISMIC CONSIDERATIONS

The seismic design requirements for sewer structure abutments are based on Seismic Design Category. Site Classification is required to determine the Seismic Design Category for a structure. The Site Classification is based on the upper 100 feet of the site profile defined by a weighted average value of either shear wave velocity, standard penetration resistance, or undrained shear strength in accordance with Section 20.4 of ASCE 7 and the International Building Code (IBC). Based on the soil properties encountered at the site and as described on the exploration logs and results, it is our professional opinion that the Seismic Site Classification is D. Subsurface exploration at this site was extended to a maximum depth of 50 feet. The site properties below the boring depth to 100 feet were estimated based on our experience and knowledge of geologic conditions of the general area. Additional deeper borings or geophysical testing may be performed to confirm the conditions below the current boring depth.

LATERAL EARTH PRESSURES

Design Parameters

Structures with unbalanced backfill levels on opposite sides should be designed for earth pressures at least equal to values indicated in the following table. Earth pressures will be influenced by structural design of the walls, conditions of wall restraint, methods of construction and/or compaction and the strength of the materials being restrained. Two wall restraint conditions are shown in the diagram below. Active earth pressure is commonly used for design of free-standing cantilever retaining walls and assumes wall movement. The “at-rest” condition assumes no wall movement and is commonly used for walls restrained at the top. The recommended design lateral earth pressures do not include a factor of safety and do not provide for possible hydrostatic pressure on the walls (unless stated).

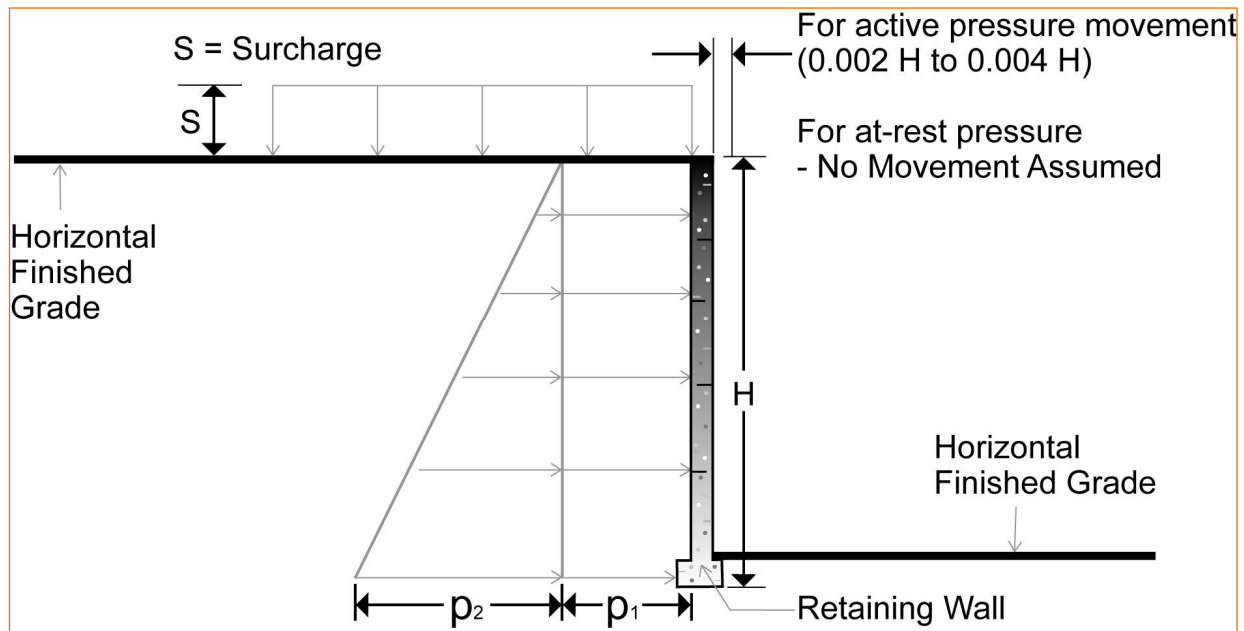

Lateral Earth Pressure Design Parameters						
Earth Pressure Condition	Coefficient for Backfill Type	Equivalent Fluid Density (pcf)		Surcharge Pressure	Equivalent Fluid Pressures p_2 (psf)	
		Drained	Submerged	p_1 (psf)	Drained	Submerged
Active (Ka)	Granular - 0.33	40	80	$(0.33)S$	$(40)H$	$(80)H$
	Fine Grained - 0.42	50	90	$(0.42)S$	$(50)H$	$(90)H$
At-Rest (Ko)	Granular - 0.50	60	90	$(0.50)S$	$(60)H$	$(90)H$
	Fine Grained - 0.59	70	100	$(0.59)S$	$(70)H$	$(100)H$
Passive (Kp)	Granular - 3.0	360	240	---	---	---
	Fine Grained - 2.37	285	205	---	---	---

- For active earth pressure, wall must rotate about base, with top lateral movements $0.002 H$ to $0.004 H$ for medium dense to loose, granular backfill, and about $0.010 H$ for compacted lean clay backfill, where H is wall height.
- For passive earth pressure resistance to develop, wall must move horizontally
- Uniform, horizontal backfill, compacted to at least 95% of the ASTM D 698 maximum dry density, rendering a maximum unit weight of 120 pcf.

- The active and at rest earth pressure coefficients will increase with the increase in backfill or uphill slope, whereas the passive earth pressure coefficient decreases with the increase in downhill slope.
- Uniform surcharge, where S is surcharge pressure.
- Loading from heavy compaction equipment is not included.
- No safety factor is included in these values.
- “Submerged” conditions are recommended when drainage behind walls is not incorporated into the design.
- Ignore passive resistance in the frost zone

Backfill placed against structures should consist of granular soils or low plasticity cohesive soils. For the granular values to be valid, the granular backfill must extend out and up from the base of the wall at an angle of at least 45 and 60 degrees from vertical for the active/at-rest and passive cases, respectively.

SLOPE STABILITY

Mechanics of Stability

Slope stability analyses take into consideration material strength, presence and orientation of weak layers, water (piezometric) pressures, surcharge loads, and the slope geometry. Mathematical computations are performed using computer-assisted simulations to calculate a Factor of Safety (FS). Minor changes to slope geometry, surface water flow and/or groundwater levels could result in slope instability. Reasonable FS values are dependent upon the confidence in the parameters utilized in the analyses performed, among other factors related to the project.

Geometric Analysis Results

Slope stability analyses were performed for the cross-section geometries obtained from the elevation contours in the *Existing Features* drawing dated March 25, 2019, prepared and provided by Snyder & Associates. Parameters used for the analyses were derived from our exploratory borings, experience, and laboratory test results. Stability analyses were conducted using the Morgenstern-Price methodology using a search routine to identify critical failure surfaces using the computer program Slope/W Version 7.16 developed by Geo-Slope International.

An approximate phreatic surface for the slope stability analyses was imported from seepage analyses. The seepage analyses were conducted using the computer program Seep/W Version 7.16 developed by Geo-Slope International. SEEP/W utilizes a two-dimensional finite element method to compute seepage flow and piezometric head. For the seepage analyses, the groundwater levels on the east and west landsides were assigned at elevation +893 feet as

observed in the soil borings and the ravine was considered empty (the water level was assigned at the ravine bed elevation +874 feet).

Back Analysis

Back analysis was performed for the cross-section geometries along the sanitary sewer line to establish field shear strength of soils and conditions at failure. Data obtained from our exploratory borings, the elevation contours of the site, and laboratory tests were used to constitute the models. Unit weights and shear strength parameters of subsurface soils were initially estimated from the laboratory tests and established correlations based on the index soil properties. Permeability parameters of soils were also estimated based on the available typical values for similar soils. Using the seepage and slope stability analyses, the estimated permeability and shear strength parameters were further adjusted/refined using the iterative back analysis of the slope to obtain a factor of safety close to 1.0 to simulate the incipient failure conditions. The adjusted/refined permeability and shear strength parameters are summarized in the following table:

Material	Hydraulic Conductivity (feet/sec)		Total Unit Weight (pcf)	Shear Strength Parameters	
	Horizontal	Vertical		Cohesion, c' (psf)	Friction Angle, φ' (degrees)
Lean Clay (CL) - Stiff	1E-6	2.5E-7	125	25	27
Sandy Lean Clay (CL) -Very Stiff to Hard (Near slope surface)	1E-6	2.5E-7	130	150*	27
Sandy Lean Clay (CL) -Very Stiff to Hard	1E-6	2.5E-7	130	300	27
Sand (SP)	1E-4	1E-4	120	0	34

* A lower cohesion value was used for the upper 6 to 7 feet of sandy lean clay soils along the slope surface and ravine bed, assuming loss of cohesion occurred due to environmental factors.

Refer to **Supporting Information** for Exhibit C-1, for the graphical output of the back analysis. The provided elevation contours do not clearly show the failure surface. Based on our filed observation, Figure 1, and elevation contours diagram, it appeared that the failure surface on the west slope started from about elevation +890 and exited at elevation +875 feet at the west slope toe. The critical slip surface in the back analysis (Exhibit C-1) appeared similar to the failure surface observed at the site. Slope stability analysis was also performed for the east ravine slope using the soil parameters presented in the preceding table. The factors of safety for the west and east slopes were calculated to be 1.01 (Exhibit C-1) and 1.24 (Exhibit C-2), respectively.

Slope Remediation Measures

For the remediation measures to prevent further loss of slope materials or progressive failure of the slope, we recommend flattening of the west slope at 1.75(H):1(V) and placing riprap at the toe of the slope (refer to Figure 2 for details). The global stability analysis was performed with this recommendation and exhibited a factor of safety of 1.35 (Exhibit C-3). The phreatic surface for this slope analysis was imported from the seepage analysis. The riprap section is also modeled/illustrated in Exhibit C-3. The riprap mass should be wrapped with a geotextile fabric to facilitate drainage and to prevent the migration of soil particles. Filtration criteria of geotextile fabrics should be checked. Consideration should be given to providing a 6-inch thick bedding stone should be provided as a cushion between the geotextile and riprap to prevent damage to the geotextile during placement of the riprap.

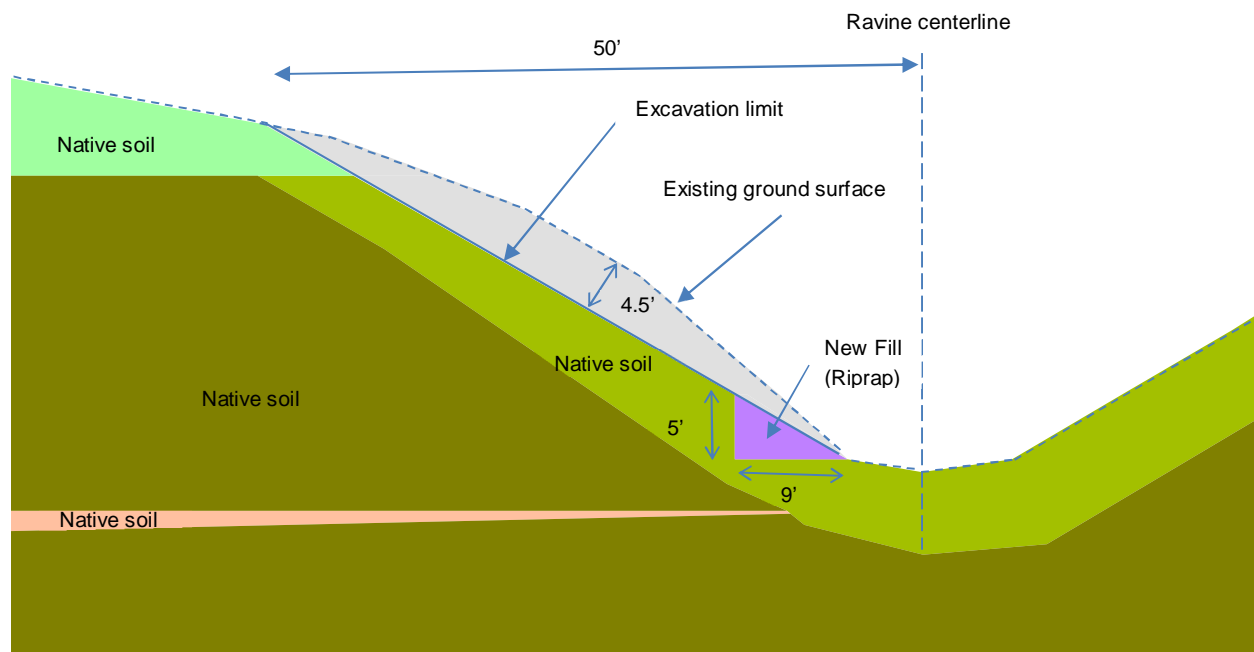

Figure 2 - Approximation of slope remediation measures for west ravine slope

Slope Stability with New Sewer Support Structure and Stabilized West Slope Toe

To determine the suitable location (horizontal distance from the crest) of a shallow foundation on both sides, slope stability analyses were performed with a maximum net allowable foundation bearing pressure of 2,500 psf, as recommended in the **Shallow Foundations** section. The *Existing Features* drawing dated March 25, 2019, indicates that the invert of the 8-inch diameter sewer pipe will be at elevation +897.67 feet. The foundation bearing level was assigned to be about 1.5 feet below the invert, at elevation 896 feet. The foundation width parallel to the sewer pipe was assigned to be 4 feet.

The position of the shallow foundation on both sides was determined for the conditions when the failure slip surface included the foundation loading and provided a factor of safety of about 1.5. The phreatic surface for these analyses was imported from the seepage analysis. Based on the results of the slope stability analyses, we recommend the shallow foundation on the west side of the ravine be placed at least 79 feet (horizontal distance) west of the ravine centerline. The shallow foundation on the east side should be installed at least 85 feet (horizontal distance) east of the ravine centerline. See Exhibits C-4 and C-5 for graphical outputs of the slope stability analyses with the foundation loading.

Based on the results of our global stability analyses, the helical piers on the west side should be installed at least 71.5 feet (horizontal distance) west from the ravine centerline (see Exhibit C-6). The helical piers on the east side of the ravine should be installed at least 77.5 feet (horizontal distance) east from the ravine centerline (see Exhibit C-7). Since the vertical load carried by the helical piers will be transmitted to the deeper very stiff to hard glacial clay and will be local, the helical pier loads were not modeled in the slope stability analyses.

GENERAL COMMENTS

Terracon should be retained to review the final design plans and specifications, so comments can be made regarding interpretation and implementation of our geotechnical recommendations in the design and specifications. In the event that changes in the nature, design, or location of the project as outlined in this report are planned, the conclusions and recommendations contained in this report shall not be considered valid unless Terracon reviews the changes and either verifies or modifies the conclusions of this report in writing. Terracon also should be retained to provide observation and testing services during grading, excavation, construction, foundation, and other earth-related construction phases of the project. Site safety, excavation support, and dewatering requirements are the responsibility of others.

The analysis and recommendations presented in this report are based upon our understanding of the project, the data obtained from the borings performed at the indicated locations and from other information discussed in this report. This report does not reflect variations that may occur between borings, across the site, or due to the modifying effects of construction or weather. The nature and extent of such variations may not become evident until during or after construction. If variations appear, we should be immediately notified so that further evaluation and supplemental recommendations can be provided.

The scope of services for this project does not include either specifically or by implication any environmental or biological (e.g., mold, fungi, bacteria) assessment of the site or identification or prevention of pollutants, hazardous materials or conditions. If the owner is concerned about the potential for such contamination or pollution, other studies should be undertaken.

Geotechnical Engineering Report

Sanitary Sewer Ravine Crossing ■ Cedar Falls, Iowa

May 9, 2019 ■ Terracon Project No. 13185123.02



Our services and any correspondence or collaboration are intended for the sole benefit and exclusive use of our client for specific application to the project discussed and are accomplished in accordance with generally accepted geotechnical engineering practices with no third-party beneficiaries intended. Any third-party access to services or correspondence is solely for information purposes to support the services provided by Terracon to our client. Reliance upon the services and any work product is limited to our client, and is not intended for third parties. Any use or reliance of the provided information by third parties is done solely at their own risk. No warranties, either express or implied, are intended or made.



I hereby certify that this engineering document was prepared by me or under my direct personal supervision and that I am a duly licensed Professional Engineer under the laws of the State of Iowa.

Jason P. Heinz
Jason Patrick Heinz, P.E.

5/9/19
Date

My license renewal date is December 31, 2020.

ATTACHMENTS

EXPLORATION AND TESTING PROCEDURES

Field Exploration

Boring Layout and Elevations: The soil boring locations were determined by Terracon personnel in the field at accessible locations. The latitudes and longitudes of the borings were determined with a handheld GPS unit (estimated horizontal accuracy of about 20 feet or less). Surface elevations at the boring locations were estimated by superimposing the boring locations onto the *Existing Features* drawing with topographic contours provided by Snyder & Associates.

Subsurface Exploration Procedures: Terracon's exploration team advanced the borings with an ATV-mounted rotary drill rig using continuous flight augers. Sampling was performed continuously in the borings using thin-walled tube or split-barrel sampling procedures. In the thin-walled tube sampling procedure, a thin-walled, seamless steel tube with a sharp cutting edge was pushed hydraulically into the soil to obtain a relatively undisturbed sample. In the split-barrel sampling procedure, a standard 2-inch outer diameter split-barrel sampling spoon was driven into the ground by a 140-pound automatic hammer falling a distance of 30 inches. The number of blows required to advance the sampling spoon the last 12 inches of a normal 18-inch penetration is recorded as the Standard Penetration Test (SPT) resistance value. The SPT resistance values, also referred to as N-values, are indicated on the boring logs at the test depths. The exploration team also observed and recorded groundwater levels during drilling and sampling. The boreholes were backfilled with auger cuttings and bentonite chips upon completion.

Our exploration team prepared field boring logs as part of the drilling operations. These field logs included visual classifications of the materials encountered during drilling and our interpretation of the subsurface conditions between samples. The sampling depths, penetration resistances, and other sampling information was recorded on the field boring logs. The samples were placed in appropriate containers and transported to our soil laboratories for testing and classification.

Geotechnical Engineering Report

Sanitary Sewer Ravine Crossing ■ Cedar Falls, Iowa
May 9, 2019 ■ Terracon Project No. 13185123.02

Laboratory Testing

Water content tests and density determinations were performed on the samples, and one unconfined compression test was performed on selected sample. The unconfined compressive strength of many samples was estimated with a hand penetrometer test.

In addition to our standard testing, the following tests were performed on selected samples:

Test	Quantity
Plastic and Liquid Limits ¹	2
Sieve Analysis	3
Consolidated-Undrained Compression Triaxial Shear tests (CIUC) ²	2

1. Results presented on boring logs
2. Refer to Exhibits A-5 to A-10

The samples were visually and tactilely classified in the laboratory. The soil descriptions presented on the boring logs for native soils are in general accordance with our enclosed General Notes and the Unified Soil Classification System. The estimated group symbol for the USCS is also shown on the boring logs, and a brief description of the USCS System is included. Additional laboratory testing could be performed to more accurately classify the samples.

Procedural standards noted above are for reference to methodology in general. In some cases, variations to methods are applied as a result of local practice or professional judgment.

Geotechnical Engineering Report

Sanitary Sewer Ravine Crossing ■ Cedar Falls, Iowa

May 9, 2019 ■ Terracon Project No. 13185123.02

SITE LOCATION AND EXPLORATION PLANS

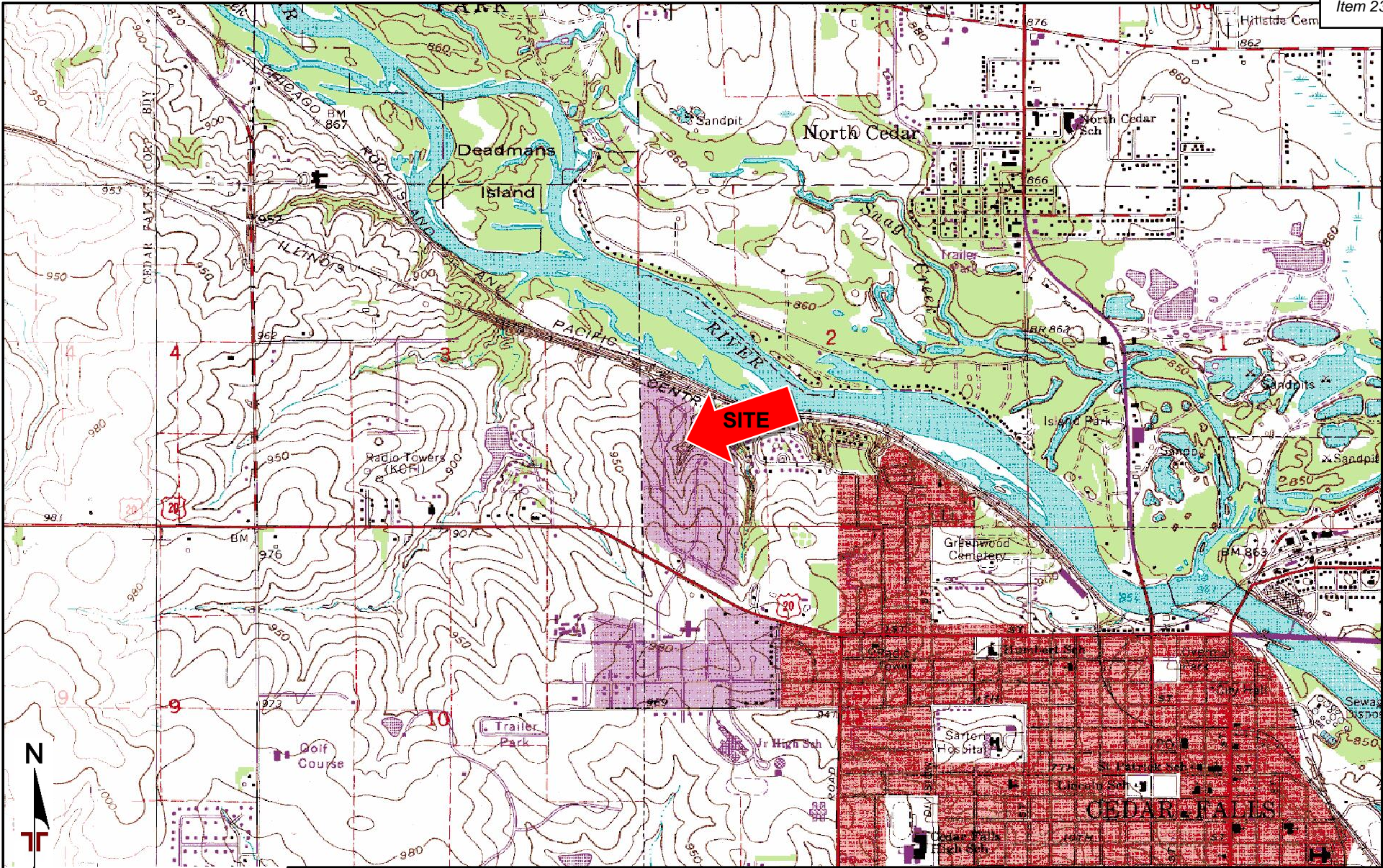

TOPOGRAPHIC MAP IMAGE COURTESY OF THE U.S. GEOLOGICAL SURVEY
 QUADRANGLES INCLUDE: NEW HARTFORD, IA (1/1/1971) and CEDAR FALLS, IA (1/1/1980).

DIAGRAM IS FOR GENERAL LOCATION ONLY, AND IS NOT INTENDED FOR CONSTRUCTION PURPOSES

Project Manager: JPH	Project No. 13185123
Drawn by: DKK	Scale: 1"=2,000'
Checked by: JPH	File Name: Click
Approved by: JPH	Date: 4/16/2019

Terracon
 3105 Capital Way, Ste 5
 Cedar Falls, IA 50613-7030

SITE LOCATION
Sanitary Sewer Ravine Crossing 2821 Minnetonka Drive Cedar Falls, IA

Exhibit A-1



bing

© 2019 Microsoft Corporation © 2019 DigitalGlobe © 2019 HERE

AERIAL PHOTOGRAPHY PROVIDED BY MICROSOFT BING MAPS

DIAGRAM IS FOR GENERAL LOCATION ONLY, AND IS NOT INTENDED FOR CONSTRUCTION PURPOSES

Project Manager: JPH
 Drawn by: DKK
 Checked by: JPH
 Approved by: JPH

Project No. 13185123
 Scale: AS SHOWN
 File Name: *Click*
 Date: 4/16/2019

Terracon
 3105 Capital Way, Ste 5
 Cedar Falls, IA 50613-7030

EXPLORATION PLAN

Sanitary Sewer Ravine Crossing
 2821 Minnetonka Drive
 Cedar Falls, IA

Exhibit
A-2

Geotechnical Engineering Report

Sanitary Sewer Ravine Crossing ■ Cedar Falls, Iowa

May 9, 2019 ■ Terracon Project No. 13185123.02

EXPLORATION RESULTS

BORING LOG NO. 1



Item 23.

PROJECT: Sanitary Sewer Ravine Crossing

CLIENT: Snyder & Associates, Inc.
Cedar Rapids, IA

SITE: 2821 Minnetonka Drive
Cedar Falls, IA

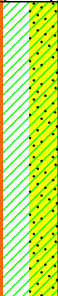
THIS BORING LOG IS NOT VALID IF SEPARATED FROM ORIGINAL REPORT. GEO SMART LOG-NO WELL_13185123 SANITARY SEWER RA.GPJ, MODEL LAYER GPJ 4/17/19

GRAPHIC LOG	LOCATION See Exploration Plan Latitude: 42.5458° Longitude: -92.4733° Surface Elev.: 907.0 (Ft.) DEPTH ELEVATION (Ft.)	DEPTH (Ft.)	WATER LEVEL OBSERVATIONS	SAMPLE TYPE	RECOVERY (in.)	FIELD TEST RESULTS	LABORATORY HP (psf)	STRENGTH TEST			WATER CONTENT (%)	DRY UNIT WEIGHT (pcf)	ATTERBERG LIMITS LL-PL-PI
								TEST TYPE	COMPRESSIVE STRENGTH (psf)	STRAIN (%)			
	FILL - TOPSOIL	2.5			22	9-5-4-5 N=9					28		
	LEAN CLAY (CL) , with sand, trace gravel, gray and brown, stiff	5			18	3-2-4-6 N=6 4000 (HP)					15		
		9			9		3000 (HP)	UC	3244	15	15	118	
		10			22	3-3-3-3 N=6	2500 (HP)				19		
		10			24	3000 (HP)					20	109	36-15-21
	SANDY LEAN CLAY (CL) , trace gravel, gray brown, very stiff	15			20	4-5-8-9 N=13 5000 (HP)					17		
		15			24	7000 (HP)					14	122	37-16-21
		15	▽		20	5-6-9-10 N=15	7000 (HP)				15		
		18				9000 (HP)							
	SANDY LEAN CLAY (CL/SC) , trace gravel, with occasional sand and silt seams, gray, very stiff to hard	20			10	4-8-7-9 N=15 9000 (HP)					19		
		20			3	4-7-8-9 N=15 8000 (HP)					17		
		25			24	3-5-9-10 N=14 9000 (HP)					14		
		25			24	3-5-8-11 N=13 9000 (HP)					14		
		25			24	4-5-9-11 N=14 9000 (HP)					15		
		30			18	5-11-15-17 N=26					16		

Stratification lines are approximate. In-situ, the transition may be gradual.

Hammer Type: Automatic

Advancement Method:
Hollow stem auger

See [Exploration and Testing Procedures](#) for a description of field and laboratory procedures used and additional data (if any).

Notes:

Abandonment Method:

See [Supporting Information](#) for explanation of symbols and abbreviations.

WATER LEVEL OBSERVATIONS

▽ 14' observed while sampling



Boring Started: 02-27-2019

Boring Completed: 02-27-2019

Drill Rig: # 546

Driller: WE

Project No.: 13185123

BORING LOG NO. 1

PROJECT: Sanitary Sewer Ravine Crossing

CLIENT: Snyder & Associates, Inc.
Cedar Rapids, IA

SITE: 2821 Minnetonka Drive
Cedar Falls, IA

GRAPHIC LOG	LOCATION See Exploration Plan Latitude: 42.5458° Longitude: -92.4733° Surface Elev.: 907.0 (Ft.)	DEPTH (Ft.)	WATER LEVEL OBSERVATIONS	SAMPLE TYPE	RECOVERY (in.)	FIELD TEST RESULTS	LABORATORY HP (psf)	STRENGTH TEST			WATER CONTENT (%)	DRY UNIT WEIGHT (pcf)	ATTERBERG LIMITS LL-PL-PI
								TEST TYPE	COMPRESSIVE STRENGTH (psf)	STRAIN (%)			
DEPTH	ELEVATION (Ft.)												
		22				5-7-11-15 N=18 9000 (HP)					15		
		18				8-7-17-18 N=24 9000 (HP)					13		
		24				4-5-11-15 N=16 9000 (HP)					15		
	36.0	871	22			12-18-27-30 N=45					13		
		20				5-10-14-12 N=24 9000 (HP)					16		
		12				5-8-13-19 N=21 9000 (HP)					16		
		20				4-9-12-15 N=21 9000 (HP)					16		
		16				13-15-15-12 N=30 9000 (HP)					15		
		24				4-8-12-16 N=20 9000 (HP)					15		
		24				3-8-12-16 N=20 9000 (HP)					16		
	50.0	857											
Boring Terminated at 50 Feet													

Stratification lines are approximate. In-situ, the transition may be gradual.

Hammer Type: Automatic

Advancement Method:
Hollow stem auger

See [Exploration and Testing Procedures](#) for a description of field and laboratory procedures used and additional data (if any).

Notes:

Abandonment Method:

See [Supporting Information](#) for explanation of symbols and abbreviations.

WATER LEVEL OBSERVATIONS

14' observed while sampling



Boring Started: 02-27-2019

Boring Completed: 02-27-2019

Drill Rig: # 546

Driller: WE

Project No.: 13185123

THIS BORING LOG IS NOT VALID IF SEPARATED FROM ORIGINAL REPORT. GEO SMART LOG-NO WELL_13185123 SANITARY SEWER RA.GPJ, MODEL LAYER.GPJ 4/17/19

BORING LOG NO. 2

Item 23.

PROJECT: Sanitary Sewer Ravine Crossing

CLIENT: Snyder & Associates, Inc.
Cedar Rapids, IA

SITE: 2821 Minnetonka Drive
Cedar Falls, IA

THIS BORING LOG IS NOT VALID IF SEPARATED FROM ORIGINAL REPORT. GEO SMART LOG-NO WELL_13185123 SANITARY SEWER RA.GPJ, MODEL LAYER GPJ 4/17/19

GRAPHIC LOG	LOCATION See Exploration Plan Latitude: 42.5455° Longitude: -92.4727° Surface Elev.: 909.0 (Ft.)	DEPTH (Ft.)	WATER LEVEL OBSERVATIONS	SAMPLE TYPE	RECOVERY (in.)	FIELD TEST RESULTS	LABORATORY HP (psf)	STRENGTH TEST			WATER CONTENT (%)	DRY UNIT WEIGHT (pcf)	ATTERBERG LIMITS	
								TEST TYPE	COMPRESSIVE STRENGTH (psf)	STRAIN (%)			LL-PL-PI	LL-PL-PI
2.0	FILL - SAND , with clay, fine to coarse grained, dark brown and gray	907		X	10	12-4-1-1 N=5					21			
4.0	LEAN CLAY (CL) , with sand, trace organics, dark brown and brown	905		X	10	1-1-2-5 N=3					37			
5	SANDY LEAN CLAY (CL) , trace gravel, with occasional sand seams, gray and brown, stiff	5		X	16	4-4-5-3 N=9 5000 (HP)					18			
10.0		10		X	16	2-3-5-7 N=8	3000 (HP)				17			
16.0	SANDY LEAN CLAY (CL) , trace gravel, with occasional sand seams, gray brown, very stiff	10		X	24	3000 (HP)		UC	2740	15	18	112	34-15-19	
15		15		X	22	3-3-5-7 N=8 7000 (HP)					16			
16.0	SANDY LEAN CLAY (CL) , trace gravel, with occasional sand and silt seams, gray, very stiff to hard	16.0		X	20	4-4-5-4 N=9 4000 (HP)					15			
20		20		X	24	5-11-13-15 N=24	9000+ (HP)				14			
25	SANDY LEAN CLAY (CL) , trace gravel, with occasional sand and silt seams, gray, very stiff to hard	20		X	16	4-7-11-17 N=18 9000 (HP)					14			
25		25		X	24	5-8-14-12 N=22 9000 (HP)					12			
30	SANDY LEAN CLAY (CL) , trace gravel, with occasional sand and silt seams, gray, very stiff to hard	25		X	24	5-7-11-13 N=18 9000 (HP)					12			
30		30		X	18	5-10-12-15 N=22 9000 (HP)					13			
30	SANDY LEAN CLAY (CL) , trace gravel, with occasional sand and silt seams, gray, very stiff to hard	30		X	22	4-8-11-16 N=19	8000 (HP)				13			
30		30		X	24	12-25-32-50 N=57					14			
30	SANDY LEAN CLAY (CL) , trace gravel, with occasional sand and silt seams, gray, very stiff to hard	30		X	24	12-25-32-50 N=57					13			
30		30		X	24	12-25-32-50 N=57					13			

Stratification lines are approximate. In-situ, the transition may be gradual.

Hammer Type: Automatic

Advancement Method:
Hollow stem auger

See [Exploration and Testing Procedures](#) for a description of field and laboratory procedures used and additional data (if any).

Notes:

Abandonment Method:
Boring backfilled with bentonite upon completion.

See [Supporting Information](#) for explanation of symbols and abbreviations.

WATER LEVEL OBSERVATIONS

▽ 16' observed while sampling
None observed after drilling



Boring Started: 02-19-2019	Boring Completed: 02-19-2019
Drill Rig: # 546	Driller: WE
Project No.: 13185123	

BORING LOG NO. 2

PROJECT: Sanitary Sewer Ravine Crossing

CLIENT: Snyder & Associates, Inc.
Cedar Rapids, IA

SITE: 2821 Minnetonka Drive
Cedar Falls, IA

GRAPHIC LOG	LOCATION See Exploration Plan Latitude: 42.5455° Longitude: -92.4727° Surface Elev.: 909.0 (Ft.)	DEPTH (Ft.)	WATER LEVEL OBSERVATIONS	SAMPLE TYPE	RECOVERY (in.)	FIELD TEST RESULTS	LABORATORY HP (psf)	STRENGTH TEST			WATER CONTENT (%)	DRY UNIT WEIGHT (pcf)	ATTERBERG LIMITS LL-PL-PI
								TEST TYPE	COMPRESSIVE STRENGTH (psf)	STRAIN (%)			
DEPTH	ELEVATION (Ft.)												
	SANDY LEAN CLAY (CL) , trace gravel, with occasional sand and silt seams, gray, very stiff to hard (<i>continued</i>)				20	9000 (HP) 8-14-28-32 N=42 6000 (HP)					14		
					22	12-16-25-28 N=41 7000 (HP)					13		
				35		20	8-14-16-24 N=30 9000 (HP)					15	
						20	20-16-20-27 N=36 9000 (HP)					17	
				40		22	7-13-13-13 N=26 9000 (HP)					16	
						24	3-7-15-14 N=22 9000 (HP)					18	
						24	5-8-12-13 N=20 9000 (HP)					15	
				45		24	5-9-12-14 N=21 9000 (HP)					15	
						20	5-8-11-15 N=19 9000 (HP)					16	
						24	5-8-11-17 N=19 9000 (HP)					15	
	Boring Terminated at 50 Feet	50.0											

Stratification lines are approximate. In-situ, the transition may be gradual.

Hammer Type: Automatic

Advancement Method:
Hollow stem auger

See [Exploration and Testing Procedures](#) for a description of field and laboratory procedures used and additional data (if any).

Notes:

Abandonment Method:
Boring backfilled with bentonite upon completion.

See [Supporting Information](#) for explanation of symbols and abbreviations.

WATER LEVEL OBSERVATIONS

16' observed while sampling
None observed after drilling

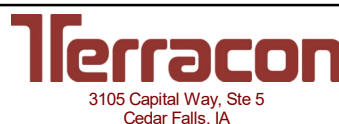

Boring Started: 02-19-2019

Boring Completed: 02-19-2019

Drill Rig: # 546

Driller: WE

Project No.: 13185123

THIS BORING LOG IS NOT VALID IF SEPARATED FROM ORIGINAL REPORT. GEO SMART LOG-NO WELL_13185123 SANITARY SEWER RA.GPJ, MODEL LAYER GPJ 4/17/19

**UNCONFINED COMPRESSION STRENGTH OF COHESIVE SOIL
ASTM D2166**

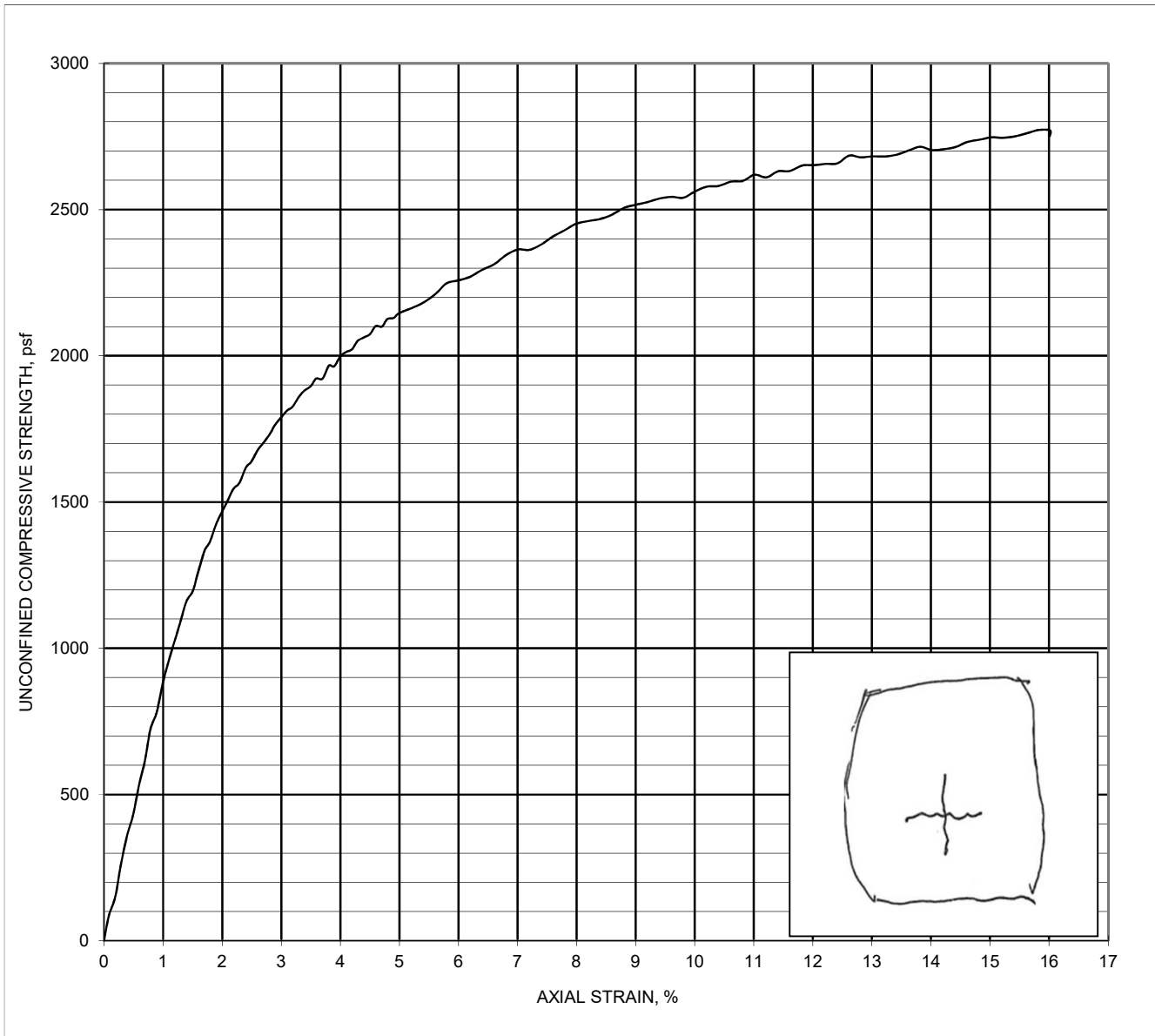

NOTE: CONTROLLED STRAIN

MACHINE ID / LOAD CELL ID	GeoJack1972 / 235166		COMPRESSIVE STRENGTH, psf	2740				
WATER CONTENT, %	18.0		STRAIN AT FAILURE, %	15.0				
DRY DENSITY, pcf	112.0		TIME TO FAILURE, minutes	7.5				
VOID RATIO	0.50		RATE OF LOADING, %/min	2.0				
SATURATION, %	96		SHEAR STRENGTH, psf	1370				
INITIAL DIAMETER, inch	2.88		INITIAL LENGTH, inch	5.84				
LENGTH TO DIAMETER RATIO	2.03		SAMPLE TYPE	UNDISTURBED				
LIQUID LIMIT	34	PLASTIC LIMIT	15	PLASTICITY INDEX	19	SPECIFIC GRAV.	2.70	ASSUMED
SAMPLE DESCRIPTION	SANDY LEAN CLAY, 10YR 4/4 DARK YELLOWISH BROWN WITH 10YR 5/1 GRAY							
BORING NO.	B-2		SAMPLE NO.	5		DEPTH, feet	8 - 14	

**SANITARY SEWER RAVINE CROSSING
CEDAR FALLS, IOWA
13085123
4/5/2019**

rms V01 12/20/08

N:\Projects - Interoffice\Cedar Falls\13185123-Sanitary Sewer Ravine Crossing Project\Lab Tests\13185123 Hydrometer Plot B1-7-12.0.xlsx\REPOR



SIEVE SIZE	DIAMETER, mm	PASS, %
1.5"	37.5	100
1"	25.0	100
3/4"	19.0	100
1/2"	12.5	98
3/8"	9.50	98
#4	4.75	98
#10	2.00	97
#20	0.850	94
#40	0.425	89
#60	0.250	80
#140	0.106	63
#200	0.075	58.9
	0.0433	53.0
	0.0313	47.4
	0.0202	41.8
	0.0118	40.0
	0.0084	36.2
	0.0061	32.5
	0.0026	27.5
	0.0012	23.5
	D60	0.0819
	D30	0.0040
	% GRAVEL	1.87595
	% SAND	39.2
	% FINES	58.9
SPECIFIC GRAVITY	2.70	ASSUMED

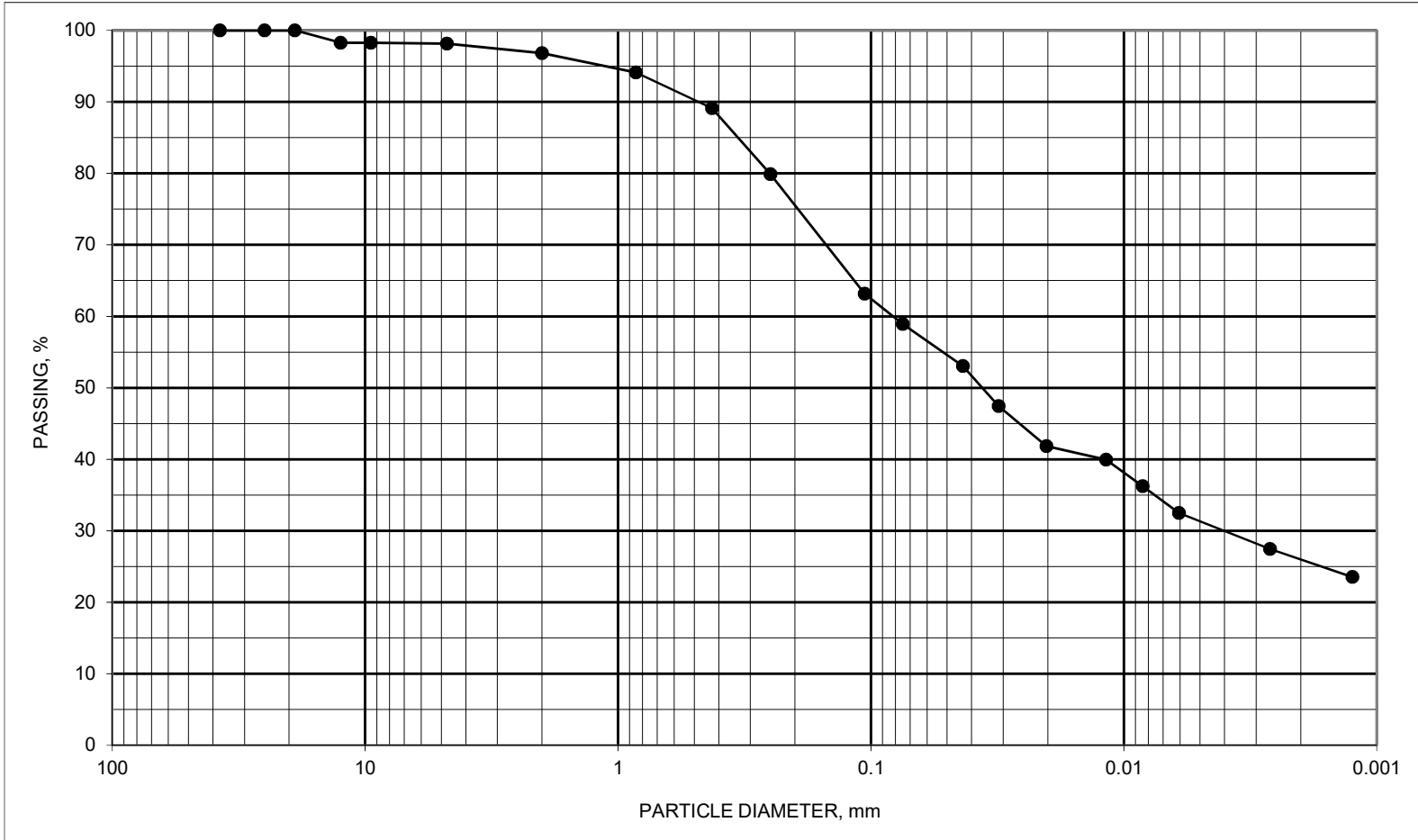

ASTM D422 PARTICLE-SIZE ANALYSIS OF SOILS

BORING ID	SAMPLE ID	DEPTH, inches	USCS DESCRIPTION	USCS SYMBOL	NAT M%	ATTERBERG LIMITS		
						LL	PL	PI
B-1	5	8 TO 10	SANDY LEAN CLAY 10YR 4/4 DARK YELLOWISH BROWN WITH 10YR 5/1 GRAY	CL		36	15	21

PROJECT SANITARY SEWER RAVINE CROSSING

CEDAR FALLS, IOWA JOB NO. 13185123.0000 DATE 4/5/2019



SIEVE SIZE	DIAMETER, mm	PASS, %
1.5"	37.5	100
1"	25.0	100
3/4"	19.0	100
1/2"	12.5	98
3/8"	9.50	98
#4	4.75	98
#10	2.00	97
#20	0.850	94
#40	0.425	89
#60	0.250	80
#140	0.106	63
#200	0.075	58.9
	0.0433	53.0
	0.0313	47.4
	0.0202	41.8
	0.0118	40.0
	0.0084	36.2
	0.0061	32.5
	0.0026	27.5
	0.0012	23.5
	D60	0.0819
	D30	0.0040
	% GRAVEL	1.87595
	% SAND	39.2
	% FINES	58.9
SPECIFIC GRAVITY	2.70	ASSUMED

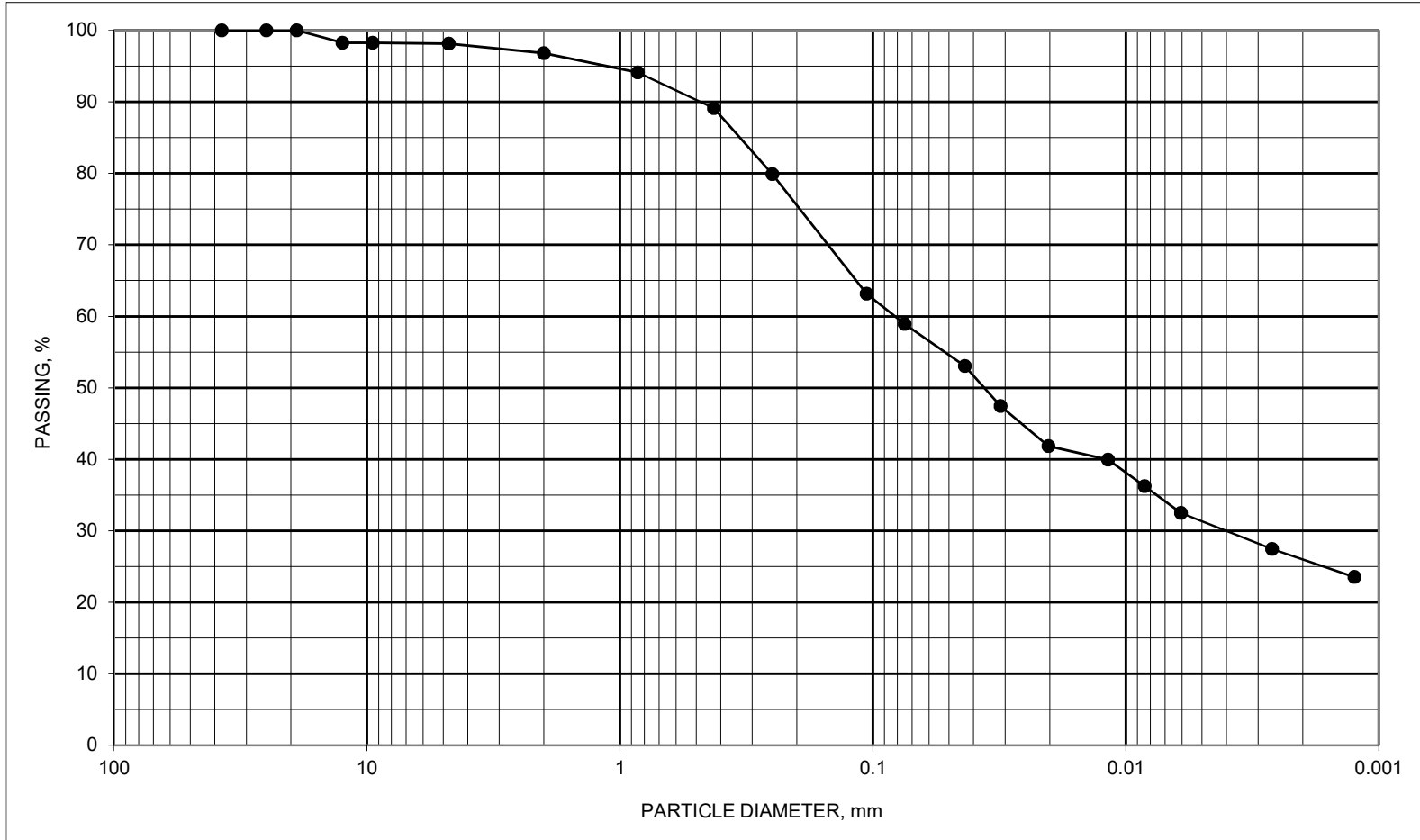

ASTM D422 PARTICLE-SIZE ANALYSIS OF SOILS

BORING ID	SAMPLE ID	DEPTH, inches	USCS DESCRIPTION	USCS SYMBOL	NAT M%	ATTERBERG LIMITS		
						LL	PL	PI
B-1	5	8 TO 10	SANDY LEAN CLAY 10YR 4/4 DARK YELLOWISH BROWN WITH 10YR 5/1 GRAY	CL		36	15	21

PROJECT SANITARY SEWER RAVINE CROSSING

CEDAR FALLS, IOWA JOB NO. 13185123.0000 DATE 4/5/2019

SIEVE SIZE	DIAMETER, mm	PASS, %
1.5"	37.5	100
1"	25.0	100
3/4"	19.0	100
1/2"	12.5	100
3/8"	9.50	100
#4	4.75	100
#10	2.00	99
#20	0.850	97
#40	0.425	92
#60	0.250	83
#140	0.106	65
#200	0.075	60.3
	0.0422	54.0
	0.0305	48.4
	0.0196	44.8
	0.0115	41.1
	0.0082	36.4
	0.0059	33.7
	0.0029	30.0
	0.0012	25.3
	D60	0.0727
	D30	0.0029
	% GRAVEL	0.10087
	% SAND	39.6
	% FINES	60.3
SPECIFIC GRAVITY	2.70	ASSUMED

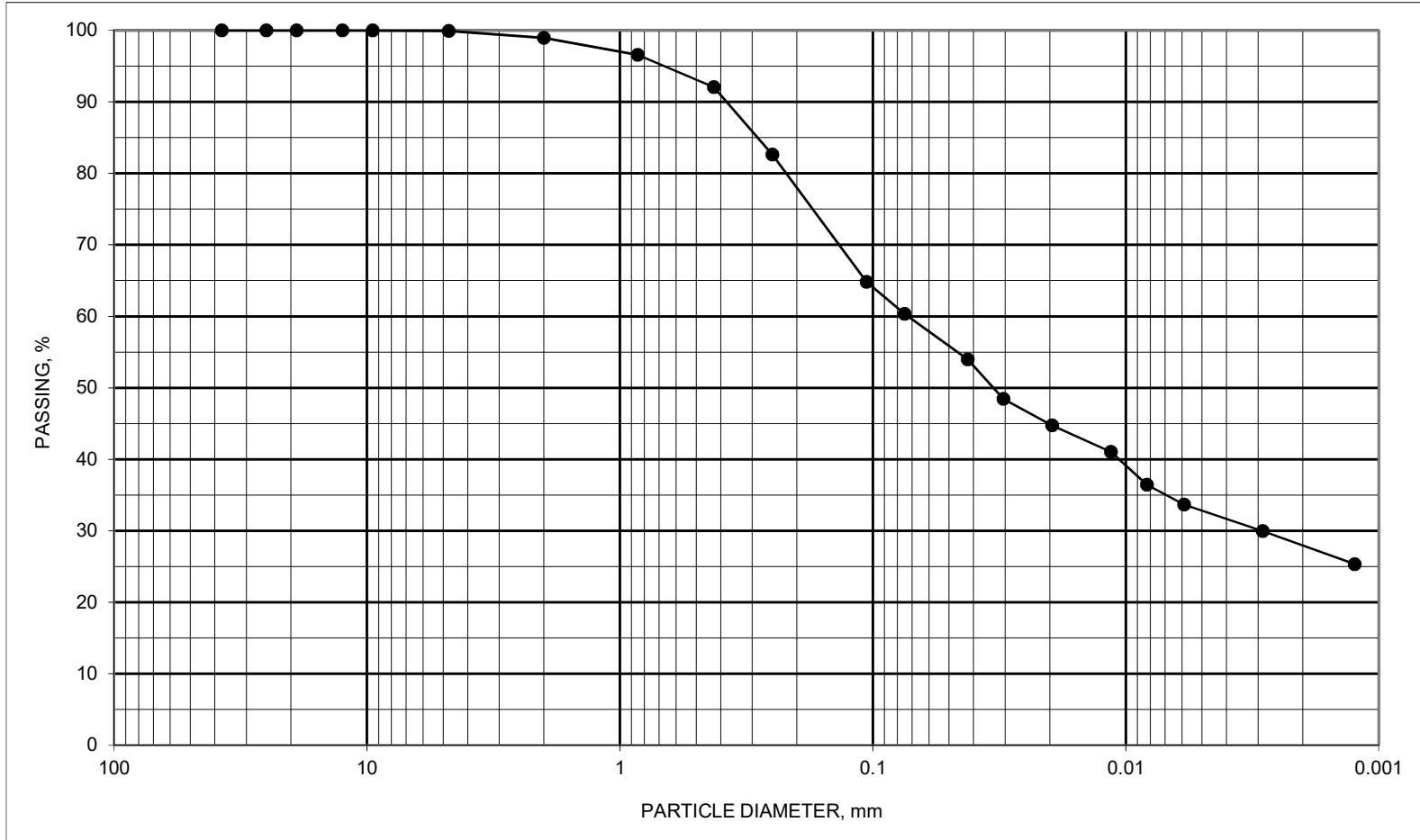

ASTM D422 PARTICLE-SIZE ANALYSIS OF SOILS

BORING ID	SAMPLE ID	DEPTH, inches	USCS DESCRIPTION	USCS SYMBOL	NAT M%	ATTERBERG LIMITS		
						LL	PL	PI
B-2	5	8 TO 10	SANDY LEAN CLAY 10YR 4/4 DARK YELLOWISH BROWN WITH 10YR 5/1 GRAY	CL		34	15	19

PROJECT SANITARY SEWER RAVINE CROSSING

CEDAR FALLS, IOWA JOB NO. 13185123.0000 DATE 4/5/2019

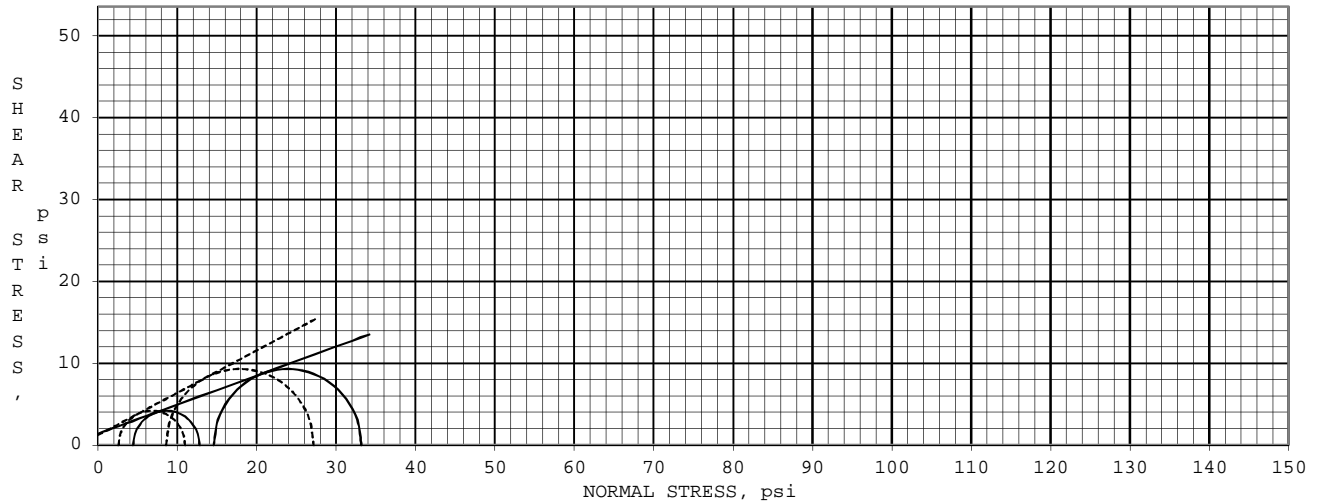

EFFECTIVE STRESS ---	ANGLE OF INTERNAL FRICTION, deg	27.4	COHESION, psi	1.2
TOTAL STRESS —	ANGLE OF INTERNAL FRICTION, deg	19.5	COHESION, psi	1.4

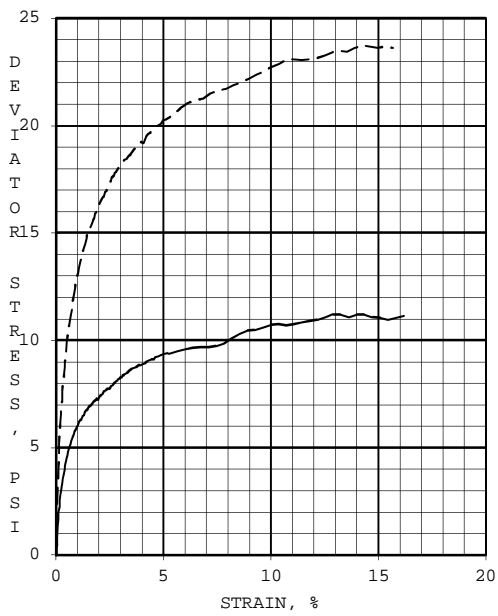

SPECIMEN ID:		A	B
INITIAL	WATER CONTENT, %	20.4	19.6
	DRY DENSITY, pcf	108.5	111.5
	SATURATION, %	99	104
BEFORE SHEAR	VOID RATIO	0.55	0.51
	WATER CONTENT, %	20.3	17.2
	DRY DENSITY, pcf	108.9	115.1
	SATURATION (B PARAMETER)	0.99	0.97
	VOID RATIO	0.55	0.46
	FINAL BACK PRESSURE, psi	100.7	100.3
	MINOR PRINCIPAL STRESS, psi	4.4	14.6
	EFFECTIVE STRESS PEAK AT % STRAIN	3.1	3.4
	EFF. DEVIATOR STRESS AT PEAK STRAIN, psi	8.4	18.6
	TOTAL STRESS PEAK AT % STRAIN	3.1	3.4
	TOTAL DEVIATOR STRESS AT PEAK STRAIN, psi	8.4	18.6
	ULTIMATE DEVIATOR STRESS (15% STR), psi	11.0	23.6
	TIME TO 50% PRIMARY CONSOLIDATION, min	7.85	34.40
	STRAIN RATE, % / hour	0.53	0.52
	INITIAL DIAMETER, inch	2.855	2.875
	INITIAL HEIGHT, inch	5.813	5.929
	AREA AFTER CONSOLIDATION, inch ²	6.625	6.349
CONTROLLED - STRAIN TEST	PROJECT: SANITARY SEWER RAVINE CROSSING		
SAMPLE TYPE: 3" SHELBY TUBE	CEDAR FALLS, IOWA		
DESCRIPTION OF SPECIMENS: SANDY LEAN CLAY, 10YR 4/4 DARK YELLOWSIH BROWN WITH 10YR 5/1 GRAY	BORING #: B-1		
LL 36 PL 15 PI 21 Gs 2.7 EST.	LABORATORY: TERRACON - LENEXA		
PROJECT NO. 13185123	SAMPLE #: 5		
	DATE: 4/5/2019		
	DEPTH, feet: 8.0 - 10.0		

PROCEDURE: ASTM D4767, CONSOLIDATED-UNDRAINED TRIAXIAL COMPRESSION TEST ON COHESIVE SOILS



SANITARY SEWER RAVINE CROSSING

13185123

B-1

5

8.0 - 10.0

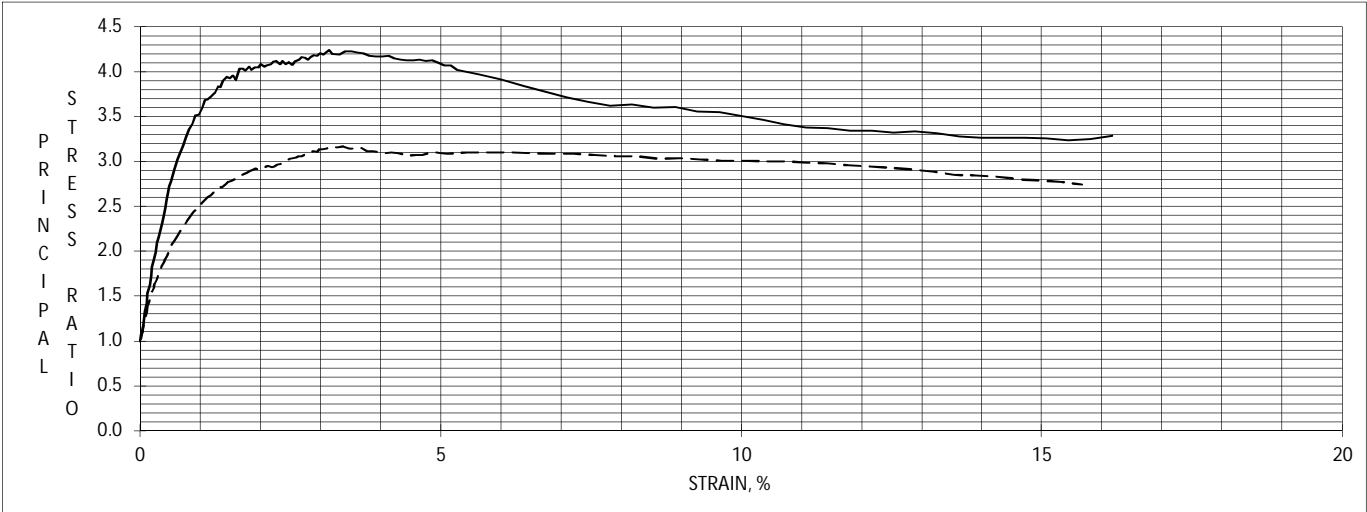

FAILURE SKETCH



SPECIMEN A

FAILURE SKETCH



SPECIMEN B

FAILURE SKETCH

SPECIMEN C

REMARKS:

SPECIMENS SATURATED BY THE WET METHOD.
 EFFECTIVE STRESS FAILURE DATA BASED ON PEAK PRINCIPAL STRESS RATIO % STRAIN.
 EFFECTIVE STRESS MOHR'S CIRCLES DRAWN AT PEAK PRINCIPAL STRESS RATIO % STRAIN.
 TOTAL STRESS FAILURE DATA BASED ON PEAK PRINCIPAL STRESS RATIO % STRAIN.
 TOTAL STRESS MOHR'S CIRCLES DRAWN AT PEAK PRINCIPAL STRESS RATIO % STRAIN.
 DEVIATOR STRESSES CORRECTED FOR MEMBRANE AND FILTER PAPER EFFECTS.
 AREA AFTER CONSOLIDATION CALCULATED AS PER SECTION 10.3.2.1 METHOD A



SANITARY SEWER RAVINE CROSSING

13185123

B-1

5

8.0 - 10.0

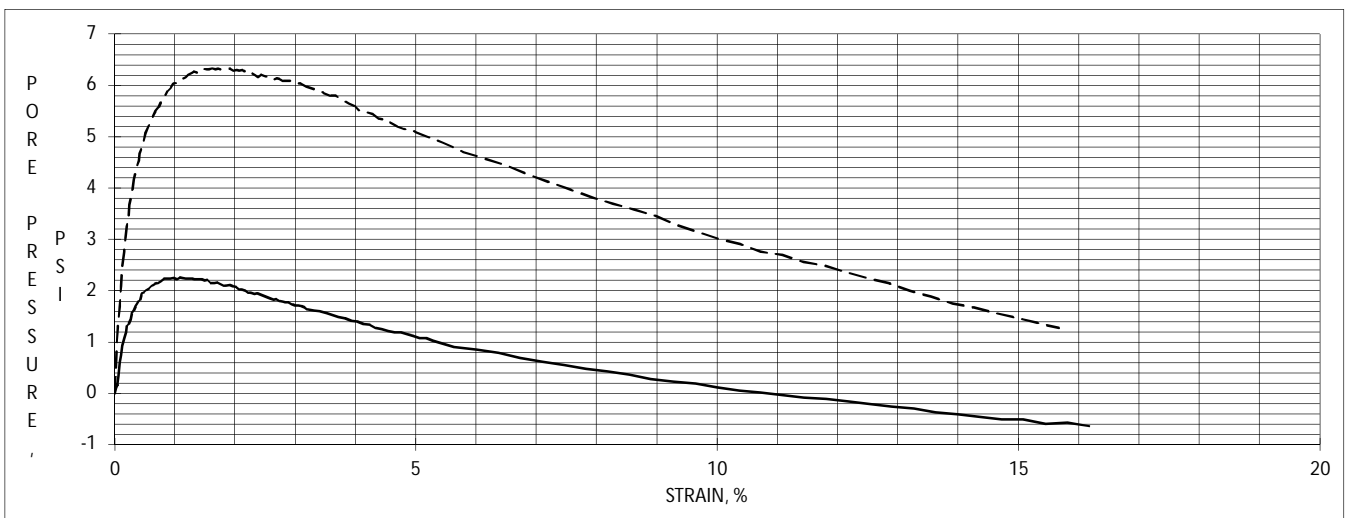
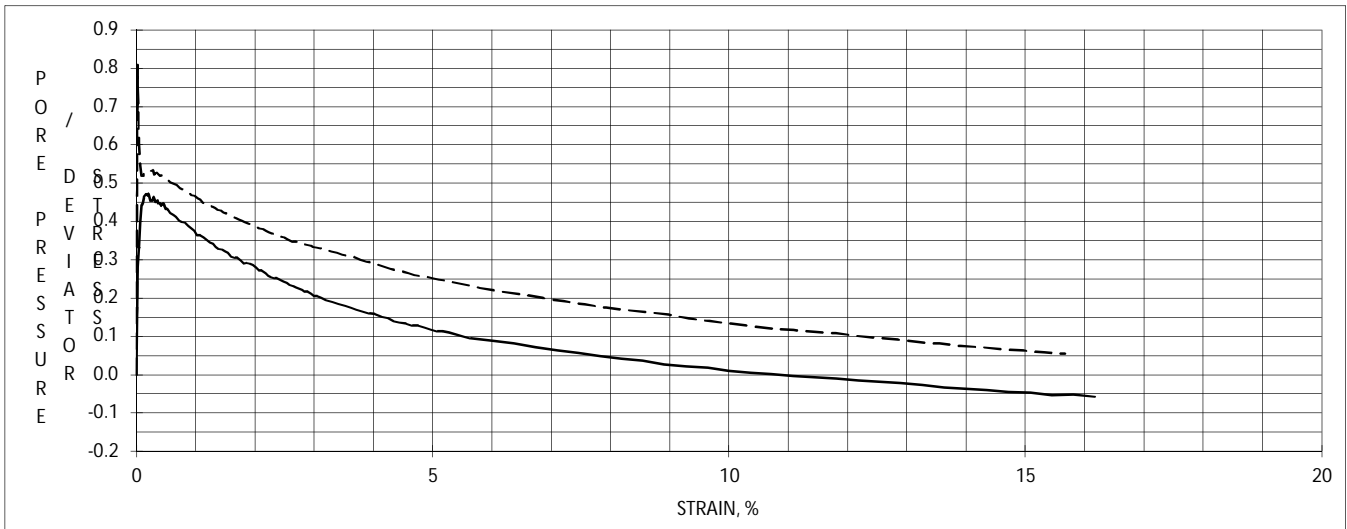
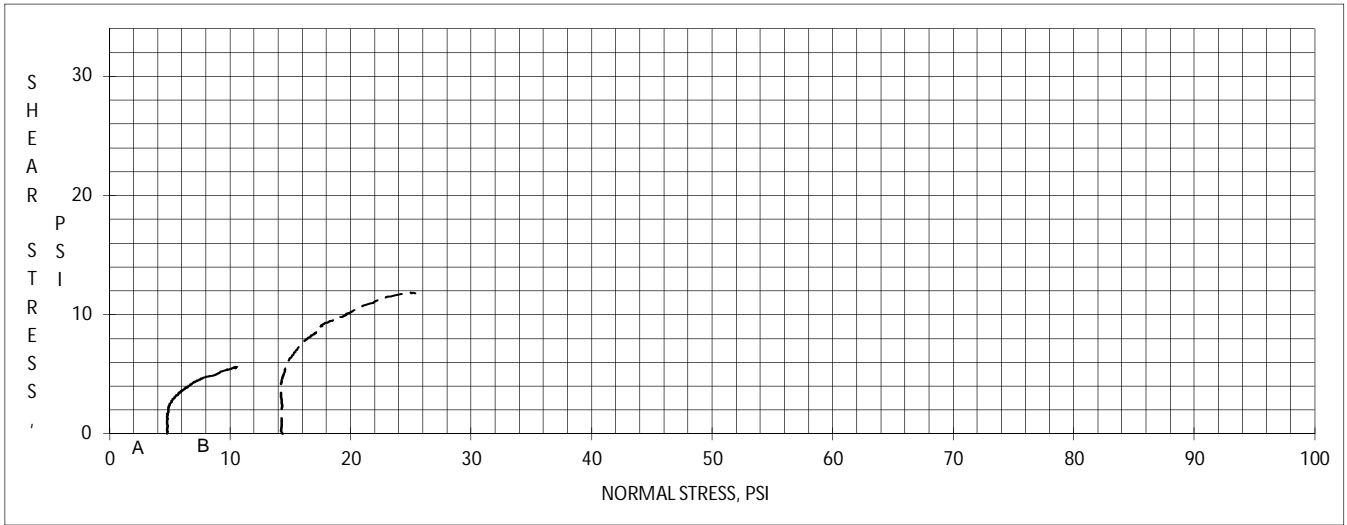

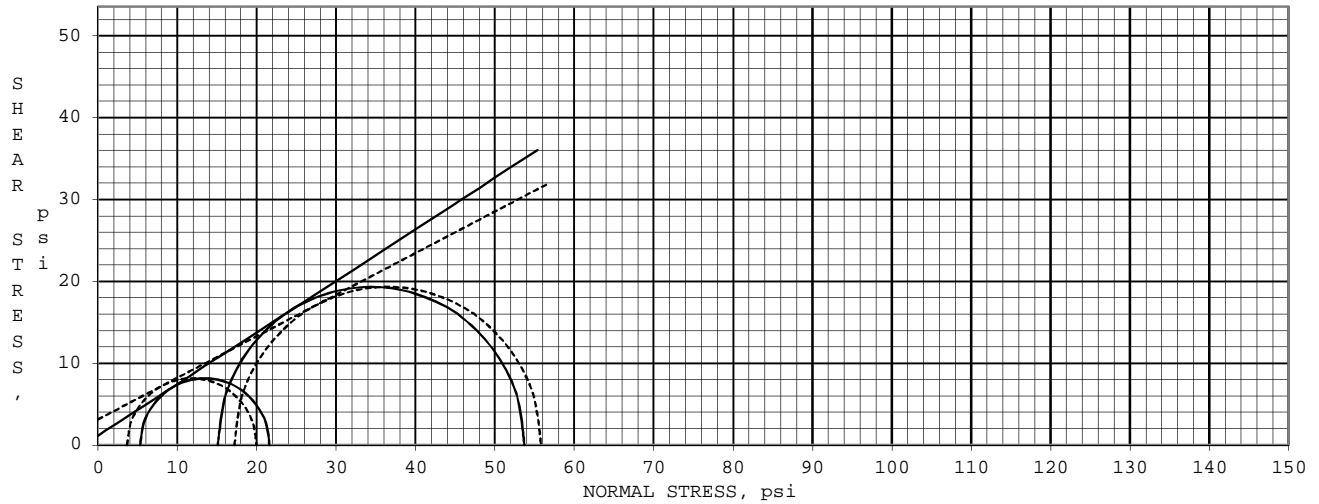

EFFECTIVE STRESS ---	ANGLE OF INTERNAL FRICTION, deg	26.9	COHESION, psi	3.1
TOTAL STRESS —	ANGLE OF INTERNAL FRICTION, deg	32.2	COHESION, psi	1.2

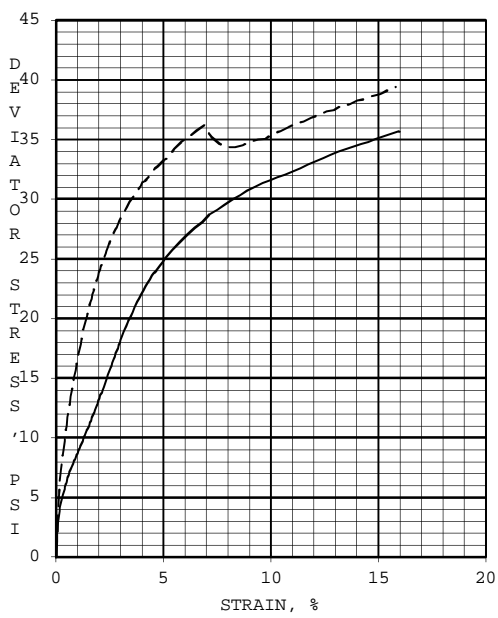

SPECIMEN ID:		A	B
INITIAL	WATER CONTENT, %	13.9	13.8
	DRY DENSITY, pcf	122.2	121.7
	SATURATION, %	99	97
BEFORE SHEAR	VOID RATIO	0.38	0.39
	WATER CONTENT, %	13.9	12.7
	DRY DENSITY, pcf	122.4	125.4
	SATURATION (B PARAMETER)	0.99	0.98
	VOID RATIO	0.38	0.34
FINAL BACK PRESSURE, psi		99.1	98.9
MINOR PRINCIPAL STRESS, psi		5.3	15.1
EFFECTIVE STRESS PEAK AT % STRAIN		2.6	15.0
EFF. DEVIATOR STRESS AT PEAK STRAIN, psi		16.3	38.6
TOTAL STRESS PEAK AT % STRAIN		2.6	15.0
TOTAL DEVIATOR STRESS AT PEAK STRAIN, psi		16.3	38.6

CONTROLLED - STRAIN TEST	ULTIMATE DEVIATOR STRESS (15% STR), psi	35.1	38.8
SAMPLE TYPE: 3" SHELBY TUBE	TIME TO 50% PRIMARY CONSOLIDATION, min	15.50	40.00
DESCRIPTION OF SPECIMENS: SANDY LEAN CLAY, 2.5Y 3/3 DARK OLIVE BROWN	STRAIN RATE, % / hour	0.43	0.45
	INITIAL DIAMETER, inch	2.871	2.870
	INITIAL HEIGHT, inch	5.813	5.760
LL 37 PL 16 PI 21 Gs 2.7 EST.	AREA AFTER CONSOLIDATION, inch ²	6.466	6.312
PROJECT NO. 13185123	PROJECT: SANITARY SEWER RAVINE CROSSING CEDAR FALLS, IOWA		
	BORING #: B-1		
LABORATORY: TERRACON - LENEXA	SAMPLE #: 7		
DATE: 4/5/2019	DEPTH, feet: 12.0 - 14.0		

PROCEDURE: ASTM D4767, CONSOLIDATED-UNDRAINED TRIAXIAL COMPRESSION TEST ON COHESIVE SOILS



SANITARY SEWER RAVINE CROSSING

13185123

B-1

7

12.0 - 14.0

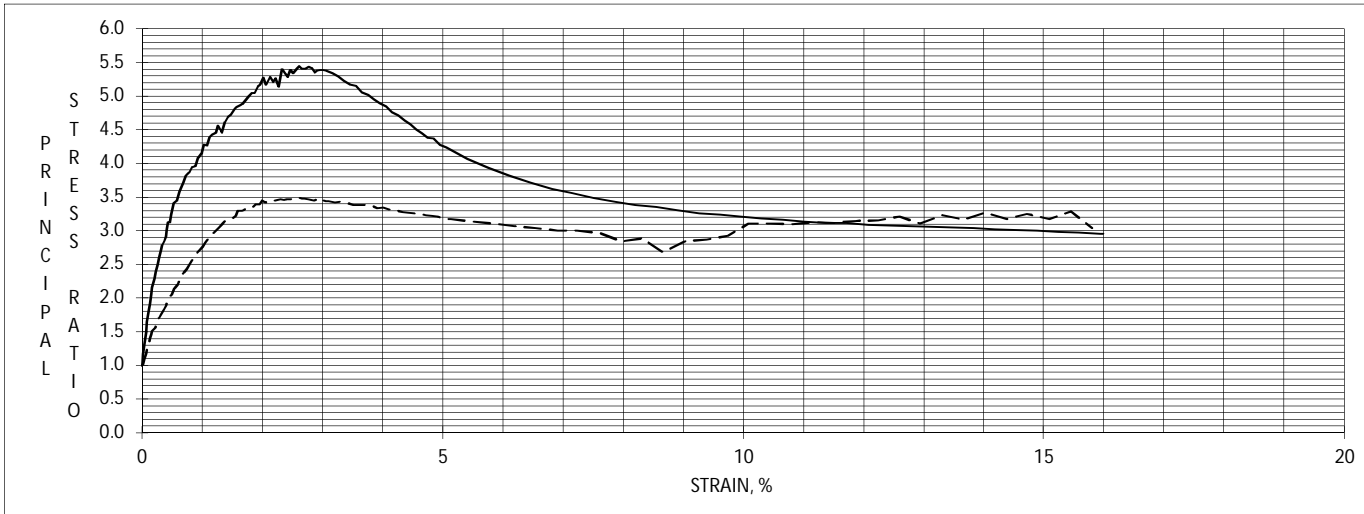

FAILURE SKETCH



SPECIMEN A

FAILURE SKETCH



SPECIMEN B

FAILURE SKETCH

SPECIMEN C

REMARKS:

SPECIMENS SATURATED BY THE WET METHOD.
 EFFECTIVE STRESS FAILURE DATA BASED ON PEAK PRINCIPAL STRESS RATIO % STRAIN.
 EFFECTIVE STRESS MOHR'S CIRCLES DRAWN AT PEAK PRINCIPAL STRESS RATIO % STRAIN.
 TOTAL STRESS FAILURE DATA BASED ON PEAK PRINCIPAL STRESS RATIO % STRAIN.
 TOTAL STRESS MOHR'S CIRCLES DRAWN AT PEAK PRINCIPAL STRESS RATIO % STRAIN.
 DEVIATOR STRESSES CORRECTED FOR MEMBRANE AND FILTER PAPER EFFECTS.
 AREA AFTER CONSOLIDATION CALCULATED AS PER SECTION 10.3.2.1 METHOD A



SANITARY SEWER RAVINE CROSSING

13185123

B-1

7

12.0 - 14.0

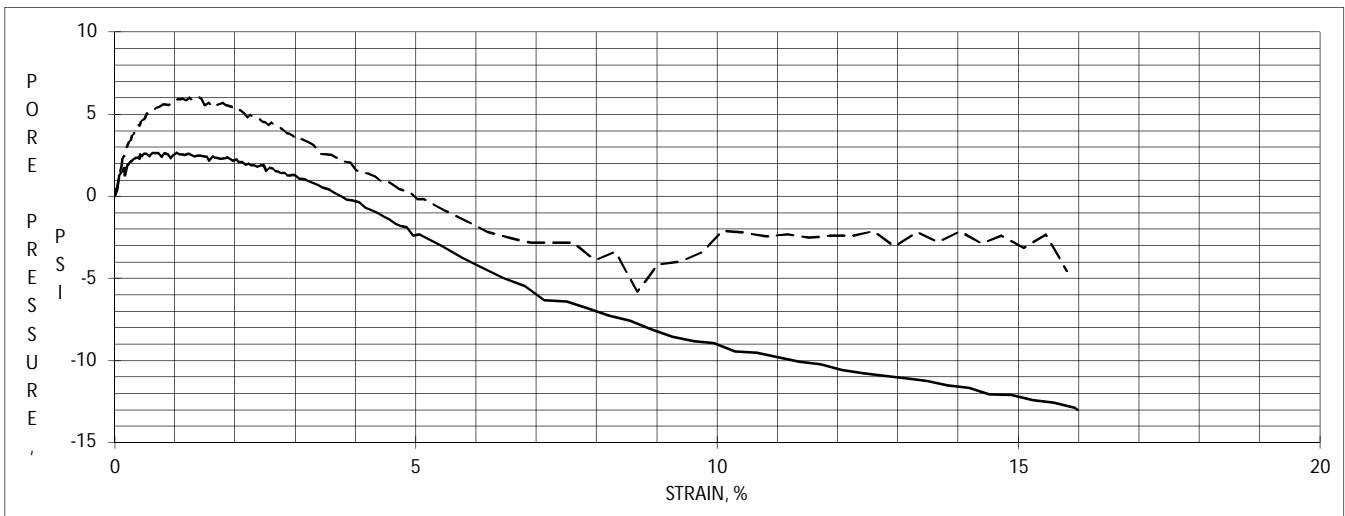
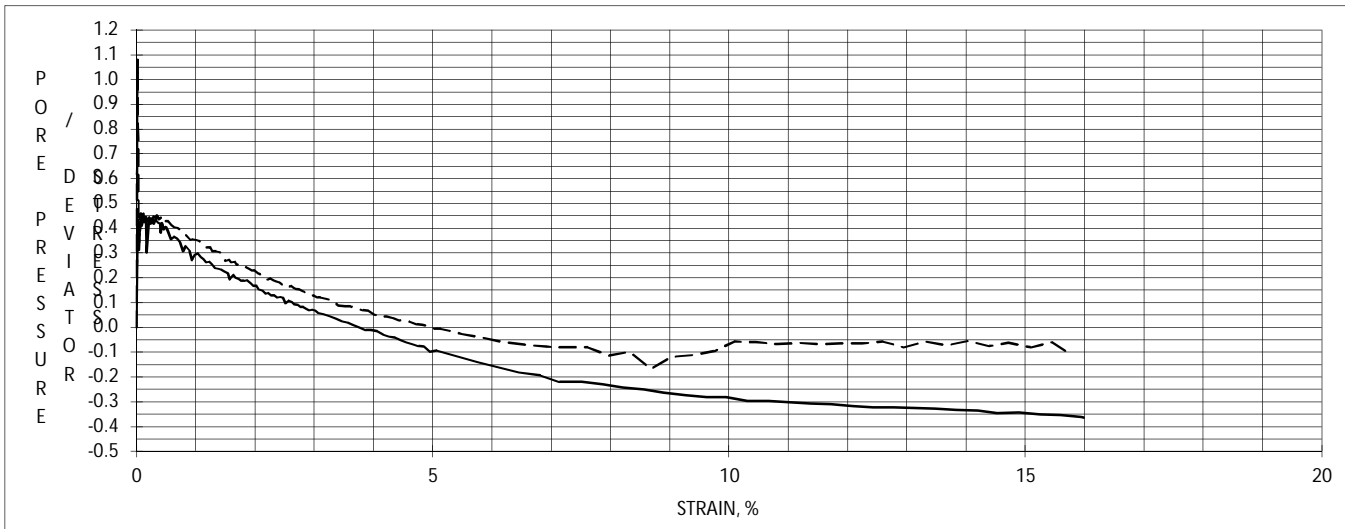
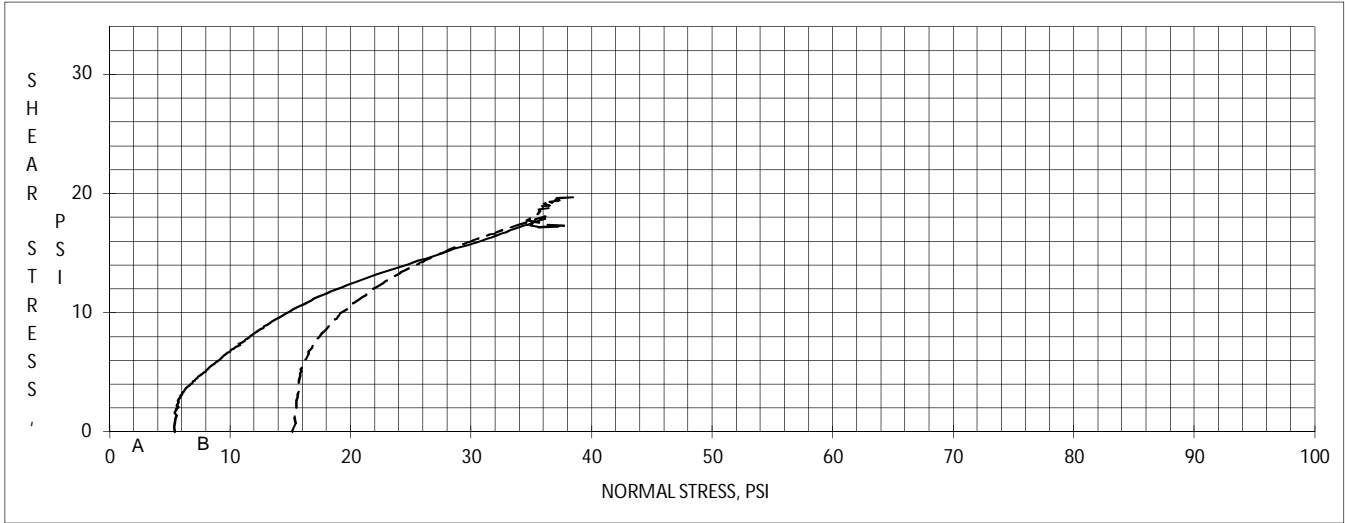

Geotechnical Engineering Report

Sanitary Sewer Ravine Crossing ■ Cedar Falls, Iowa

May 9, 2019 ■ Terracon Project No. 13185123.02

SUPPORTING INFORMATION

EXISTING WEST SLOPE

Project :Sanitary Sewer Ravine Crossing
 Location: Cedar Falls, Iowa
 Terracon Project No. : 13185123
 File Name: 13185123-Sanitary Sewer Ravine Crossing GS_Rev.gsz
 Created By: Khatri, Deep K
 Date: 4/16/2019

Color	Name	Unit Weight (pcf)	Cohesion' (psf)	Phi' (°)
Light Green	Lean Clay (CL)-Stiff	125	25	27
Light Orange	Sand (SP)	120	0	34
Light Blue	Sand Lean Clay (CL) - Stiff	130	25	27
Yellow-Green	Sand Lean Clay (CL)-V. Stiff to Hard (near Slope Surface)	130	150	27
Dark Olive	Sandy Lean Clay 2 (CL) -Very Stiff to Hard (2)	130	300	27

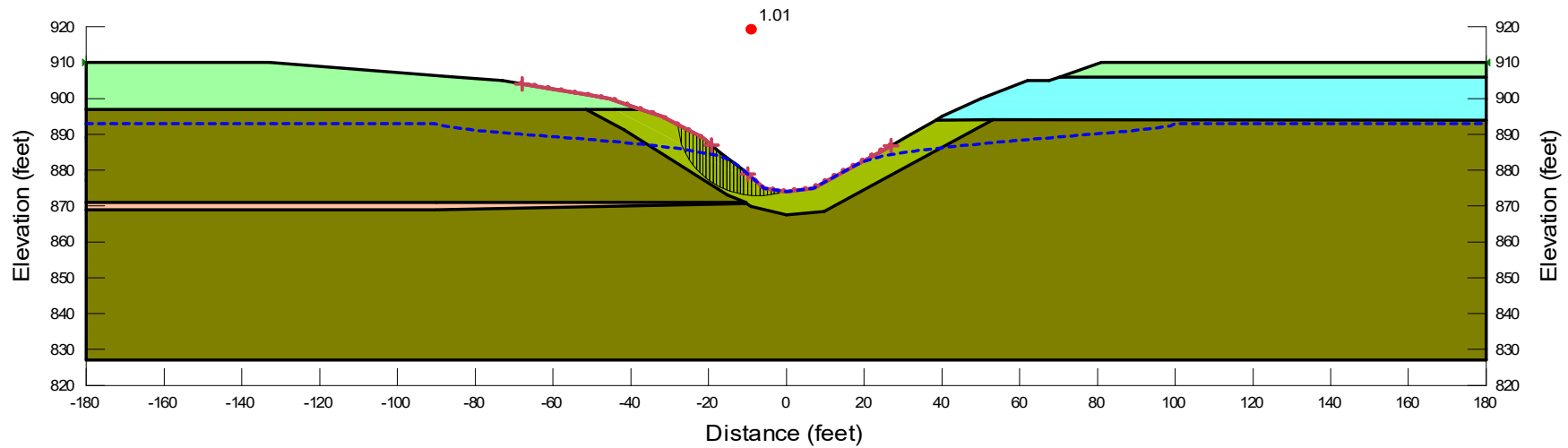



Drawn by: DKK	Exhibit C-1
Reviewed by: JPH	
Scale: As Shown	Global Slope Stability Analysis Sanitary Sewer Ravine Crossing Cedar Falls, Iowa
Terracon Project No. 13185123	Terracon

EXISTING EAST SLOPE

Project :Sanitary Sewer Ravine Crossing
 Location: Cedar Falls, Iowa
 Terracon Project No. : 13185123
 File Name: 13185123-Sanitary Sewer Ravine Crossing GS_Rev.gsz
 Created By: Khatri, Deep K
 Date: 4/17/2019

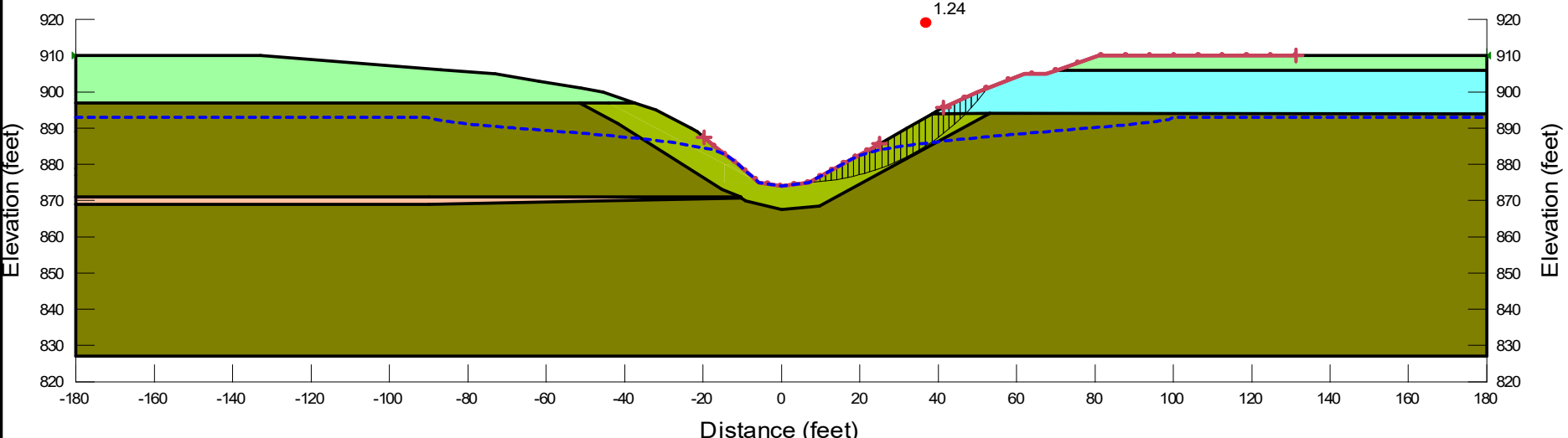
Color	Name	Unit Weight (pcf)	Cohesion' (psf)	Phi' (°)
Light Green	Lean Clay (CL)-Stiff	125	25	27
Light Orange	Sand (SP)	120	0	34
Cyan	Sandy Lean Clay (CL) - Stiff	130	25	27
Yellow-Green	Sandy Lean Clay (CL)-V. Stiff to Hard (near Slope Surface)	130	150	27
Olive Green	Sandy Lean Clay 2 (CL) -Very Stiff to Hard (2)	130	300	27



Drawn by:	Exhibit C-2 Global Slope Stability Analysis Sanitary Sewer Ravine Crossing Cedar Falls, Iowa 
DKK	
Reviewed by:	
JPH	
Scale:	
As Shown	
Terracon Project No.	
13185123	

WEST SLOPE WITH REMEDIATION MEASURES

Project :Sanitary Sewer Ravine Crossing
 Location: Cedar Falls, Iowa
 Terracon Project No. : 13185123
 File Name: 13185123-Sanitary Sewer Ravine Crossing GS_Rev.gsz
 Created By: Khatri, Deep K
 Date: 4/16/2019

Color	Name	Unit Weight (pcf)	Cohesion' (psf)	Phi' (°)
Light Green	Lean Clay (CL)-Stiff	125	25	27
Grey	NULL			
Purple	Riprap	110	0	45
Orange	Sand (SP)	120	0	34
Cyan	Sand Lean Clay (CL) - Stiff	130	25	27
Light Green	Sand Lean Clay (CL)-V. Stiff to Hard (near Slope Surface)	130	150	27
Dark Green	Sandy Lean Clay 2 (CL) -Very Stiff to Hard (2)	130	300	27

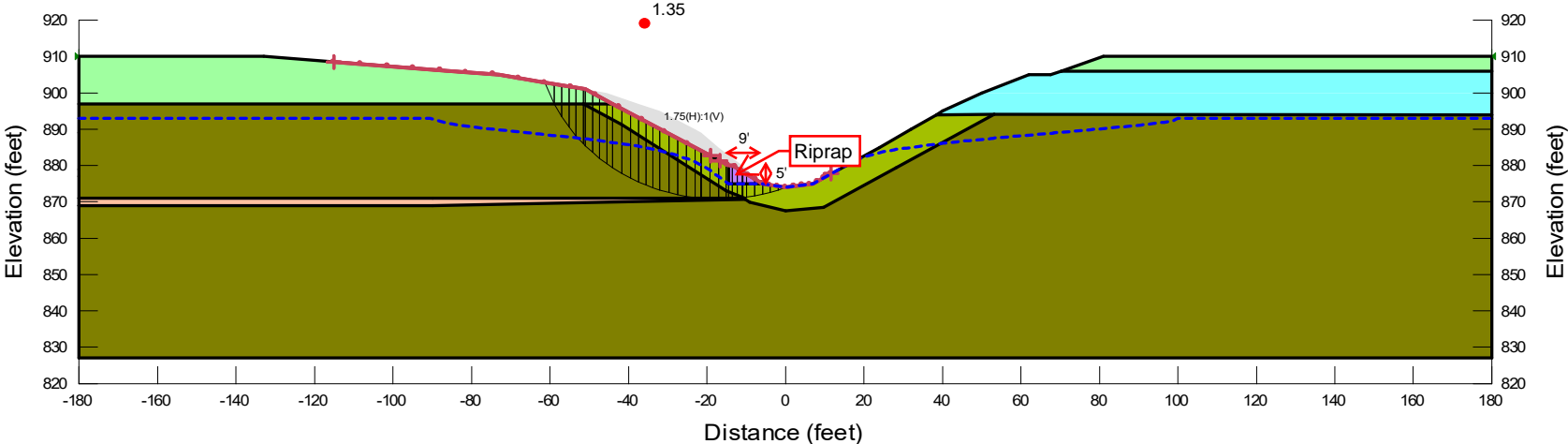

Drawn by:	DKK	Exhibit C-3
Reviewed by:		
JPH	Global Slope Stability Analysis	
Scale:	Sanitary Sewer Ravine Crossing	
As Shown	Cedar Falls, Iowa	
Terracon Project No.	Terracon	
13185123		

WEST SLOPE WITH SPREAD FOOTING LOAD

Project :Sanitary Sewer Ravine Crossing
 Location: Cedar Falls, Iowa
 Terracon Project No. : 13185123
 File Name: 13185123-Sanitary Sewer Ravine Crossing GS_Rev.gsz
 Created By: Khatri, Deep K
 Date: 4/16/2019

Color	Name	Unit Weight (pcf)	Cohesion (psf)	Phi (°)
Light Green	Lean Clay (CL)-Stiff	125	25	27
Grey	NULL			
Purple	Riprap	110	0	45
Orange	Sand (SP)	120	0	34
Cyan	Sand Lean Clay (CL) - Stiff	130	25	27
Light Green	Sand Lean Clay (CL)-V. Stiff to Hard (near Slope Surface)	130	150	27
Olive Green	Sandy Lean Clay 2 (CL) -Very Stiff to Hard (2)	130	300	27

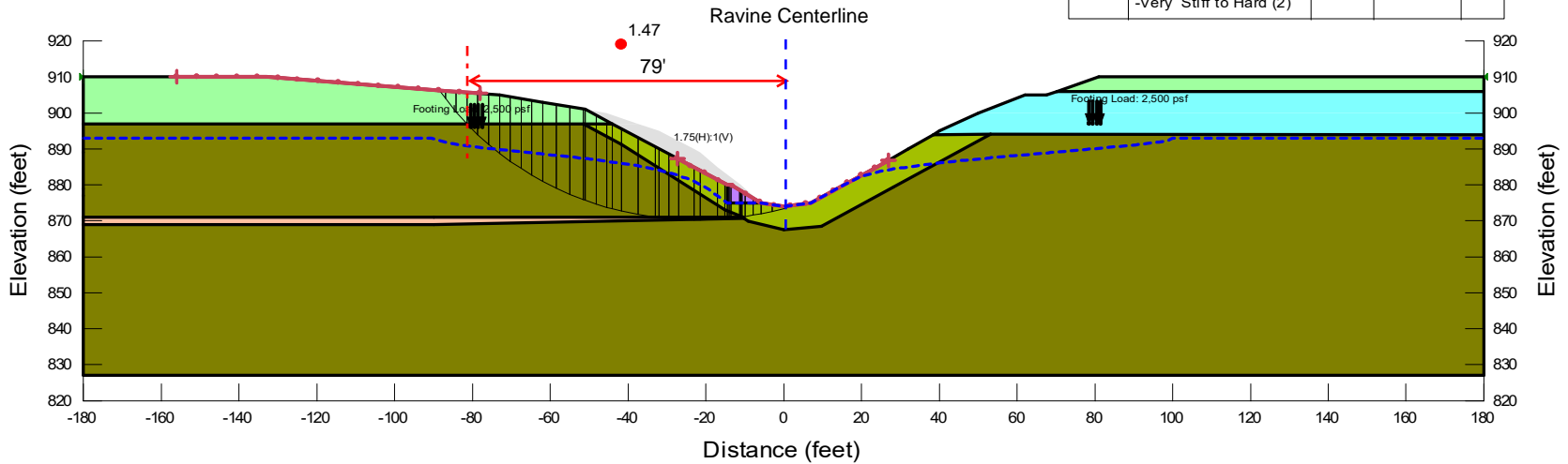

Drawn by:	DKK	Exhibit C-4
Reviewed by:		
JPH	Global Slope Stability Analysis	
Scale:	Sanitary Sewer Ravine Crossing	
As Shown	Cedar Falls, Iowa	
Terracon Project No.	Terracon	
13185123		

EAST SLOPE WITH SPREAD FOOTING LOAD

Project :Sanitary Sewer Ravine Crossing
 Location: Cedar Falls, Iowa
 Terracon Project No. : 13185123
 File Name: 13185123-Sanitary Sewer Ravine Crossing GS_Rev.gsz
 Created By: Khatri, Deep K
 Date: 4/16/2019

Color	Name	Unit Weight (pcf)	Cohesion' (psf)	Phi' (°)
Light Green	Lean Clay (CL)-Stiff	125	25	27
Grey	NULL			
Purple	Riprap	110	0	45
Orange	Sand (SP)	120	0	34
Cyan	Sand Lean Clay (CL) - Stiff	130	25	27
Light Green	Sand Lean Clay (CL)-V. Stiff to Hard (near Slope Surface)	130	150	27
Dark Green	Sandy Lean Clay 2 (CL) -Very Stiff to Hard (2)	130	300	27

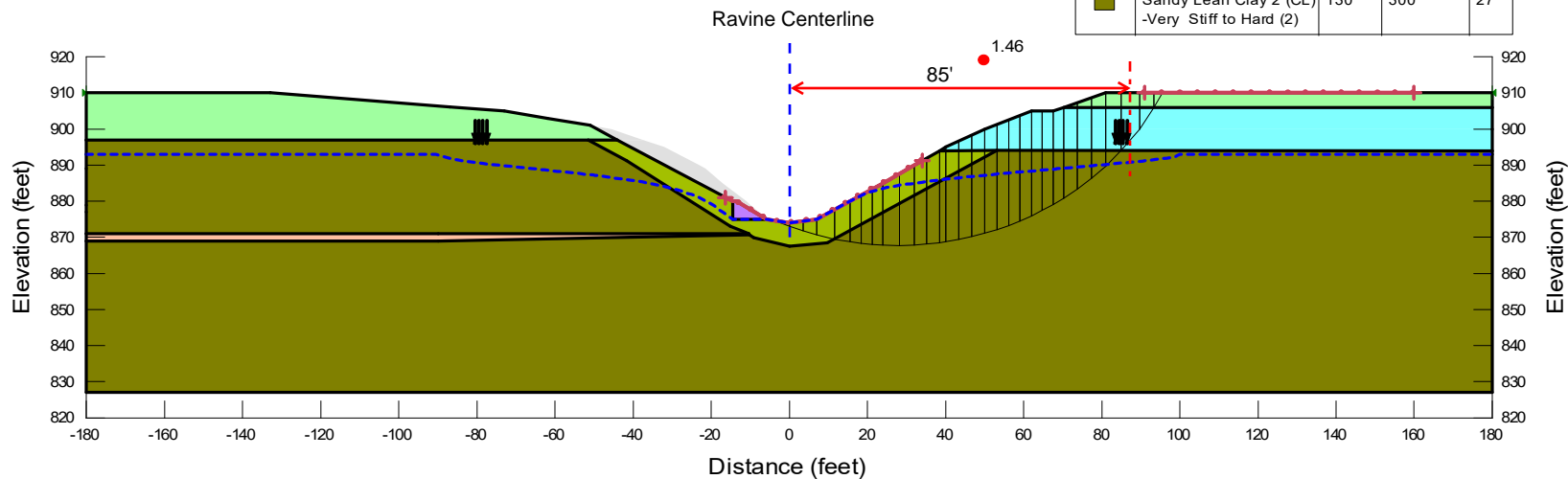

Drawn by:	DKK	<h2>Exhibit C-5</h2> <p>Global Slope Stability Analysis Sanitary Sewer Ravine Crossing Cedar Falls, Iowa</p>
Reviewed by:		
JPH		
Scale:		
As Shown		
Terracon Project No.		
13185123		

WEST SLOPE - HELICAL PIER

Project :Sanitary Sewer Ravine Crossing
 Location: Cedar Falls, Iowa
 Terracon Project No. : 13185123
 File Name: 13185123-Sanitary Sewer Ravine Crossing GS_Rev.gsz
 Created By: Khatri, Deep K
 Date: 4/17/2019

Color	Name	Unit Weight (pcf)	Cohesion (psf)	Phi (°)
Light Green	Lean Clay (CL)-Stiff	125	25	27
Grey	NULL			
Purple	Riprap	110	0	45
Orange	Sand (SP)	120	0	34
Cyan	Sandy Lean Clay (CL) - Stiff	130	25	27
Light Green	Sandy Lean Clay (CL)-V. Stiff to Hard (near Slope Surface)	130	150	27
Dark Green	Sandy Lean Clay 2 (CL) -Very Stiff to Hard (2)	130	300	27

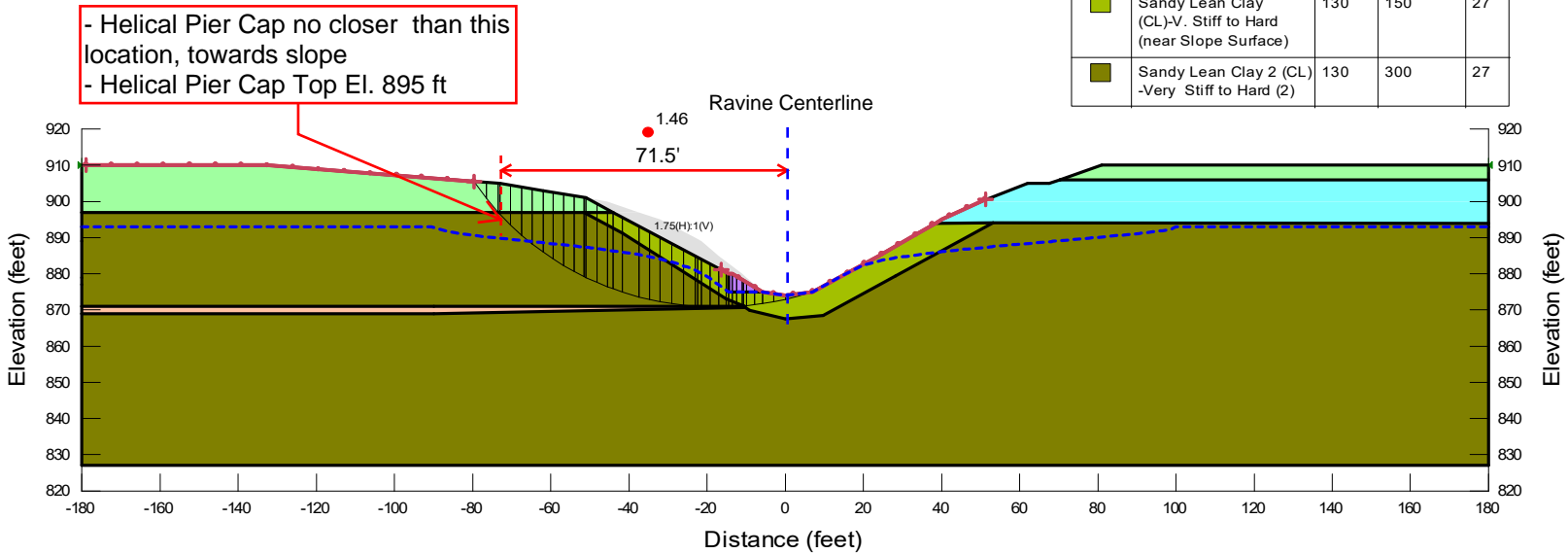

Drawn by:	DKK	<h2>Exhibit C-6</h2> <p>Global Slope Stability Analysis Sanitary Sewer Ravine Crossing Cedar Falls, Iowa</p> 
Reviewed by:		
JPH		
Scale:		
As Shown		
Terracon Project No.	13185123	

EAST SLOPE - HELICAL PIER

Project :Sanitary Sewer Ravine Crossing
 Location: Cedar Falls, Iowa
 Terracon Project No. : 13185123
 File Name: 13185123-Sanitary Sewer Ravine Crossing GS_Rev.gsz
 Created By: Khatri, Deep K
 Date: 4/17/2019

Color	Name	Unit Weight (pcf)	Cohesion' (psf)	Phi' (°)
Light Green	Lean Clay (CL)-Stiff	125	25	27
Grey	NULL			
Purple	Riprap	110	0	45
Orange	Sand (SP)	120	0	34
Cyan	Sandy Lean Clay (CL) - Stiff	130	25	27
Light Yellow-Green	Sandy Lean Clay (CL)-V. Stiff to Hard (near Slope Surface)	130	150	27
Dark Olive Green	Sandy Lean Clay 2 (CL) -Very Stiff to Hard (2)	130	300	27

- Helical Pier Cap no closer than this location, towards slope
 - Helical Pier Cap Top El. 895 ft

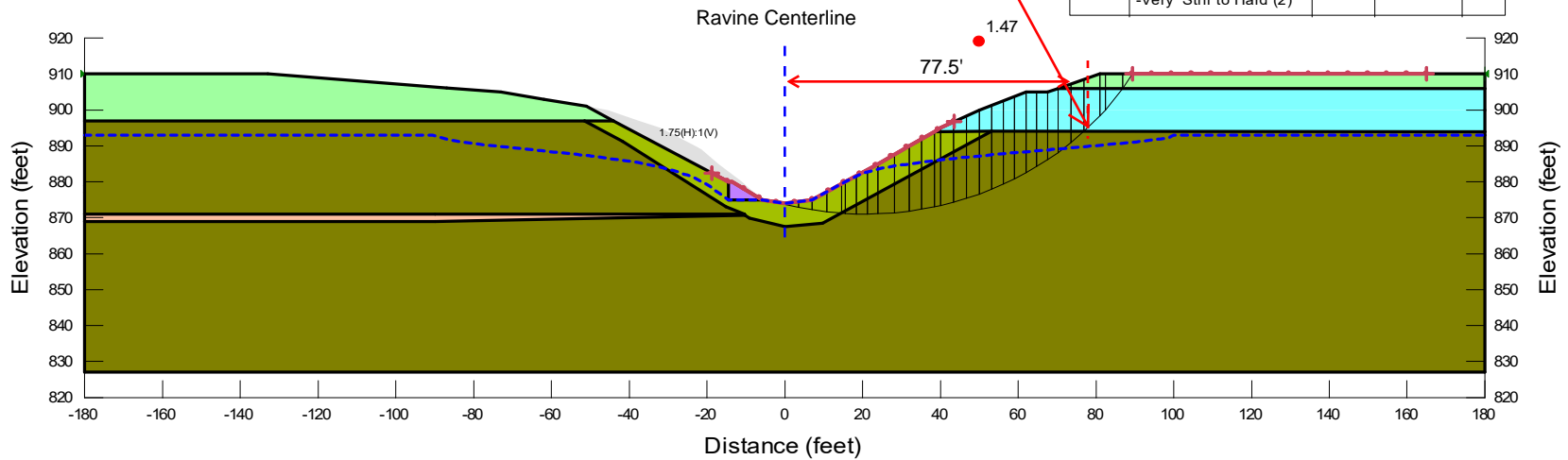





Drawn by:	DKK	Exhibit C-7
Reviewed by:		
JPH	Global Slope Stability Analysis	
Scale:	Sanitary Sewer Ravine Crossing	
As Shown	Cedar Falls, Iowa	
Terracon Project No.	Terracon	
13185123		

GENERAL NOTES

DESCRIPTION OF SYMBOLS AND ABBREVIATIONS

Sanitary Sewer Ravine Crossing ■ Cedar Falls, IA

May 9, 2019 ■ Terracon Project No. 13185123.02

SAMPLING	WATER LEVEL	FIELD TESTS
 Shelby Tube  Split Spoon	 Water Initially Encountered  Water Level After a Specified Period of Time  Water Level After a Specified Period of Time Water levels indicated on the soil boring logs are the levels measured in the borehole at the times indicated. Groundwater level variations will occur over time. In low permeability soils, accurate determination of groundwater levels is not possible with short term water level observations.	N Standard Penetration Test Resistance (Blows/Ft.) (HP) Hand Penetrometer (T) Torvane (DCP) Dynamic Cone Penetrometer UC Unconfined Compressive Strength (PID) Photo-ionization Detector (OVA) Organic Vapor Analyzer

DESCRIPTIVE SOIL CLASSIFICATION

Soil classification is based on the Unified Soil Classification System. Coarse Grained Soils have more than 50% of their dry weight retained on a #200 sieve; their principal descriptors are: boulders, cobbles, gravel or sand. Fine Grained Soils have less than 50% of their dry weight retained on a #200 sieve; they are principally described as clays if they are plastic, and silts if they are slightly plastic or non-plastic. Major constituents may be added as modifiers and minor constituents may be added according to the relative proportions based on grain size. In addition to gradation, coarse-grained soils are defined on the basis of their in-place relative density and fine-grained soils on the basis of their consistency.

LOCATION AND ELEVATION NOTES

Unless otherwise noted, Latitude and Longitude are approximately determined using a hand-held GPS device. The accuracy of such devices is variable. Surface elevation data annotated with +/- indicates that no actual topographical survey was conducted to confirm the surface elevation. Instead, the surface elevation was approximately determined from topographic maps of the area.

STRENGTH TERMS

RELATIVE DENSITY OF COARSE-GRAINED SOILS <small>(More than 50% retained on No. 200 sieve.) Density determined by Standard Penetration Resistance</small>		CONSISTENCY OF FINE-GRAINED SOILS <small>(50% or more passing the No. 200 sieve.) Consistency determined by laboratory shear strength testing, field visual-manual procedures or standard penetration resistance</small>		
Descriptive Term (Density)	Standard Penetration or N-Value Blows/Ft.	Descriptive Term (Consistency)	Unconfined Compressive Strength Qu, (psf)	Standard Penetration or N-Value Blows/Ft.
Very Loose	0 - 3	Very Soft	less than 500	0 - 1
Loose	4 - 9	Soft	500 to 1,000	2 - 4
Medium Dense	10 - 29	Medium Stiff	1,000 to 2,000	4 - 8
Dense	30 - 50	Stiff	2,000 to 4,000	8 - 15
Very Dense	> 50	Very Stiff	4,000 to 8,000	15 - 30
		Hard	> 8,000	> 30

RELATIVE PROPORTIONS OF SAND AND GRAVEL		RELATIVE PROPORTIONS OF FINES	
Descriptive Term(s) of other constituents	Percent of Dry Weight	Descriptive Term(s) of other constituents	Percent of Dry Weight
Trace	<15	Trace	<5
With	15-29	With	5-12
Modifier	>30	Modifier	>12

GRAIN SIZE TERMINOLOGY		PLASTICITY DESCRIPTION	
Major Component of Sample	Particle Size	Term	Plasticity Index
Boulders	Over 12 in. (300 mm)	Non-plastic	0
Cobbles	12 in. to 3 in. (300mm to 75mm)	Low	1 - 10
Gravel	3 in. to #4 sieve (75mm to 4.75 mm)	Medium	11 - 30
Sand	#4 to #200 sieve (4.75mm to 0.075mm)	High	> 30
Silt or Clay	Passing #200 sieve (0.075mm)		

Criteria for Assigning Group Symbols and Group Names Using Laboratory Tests ^A				Soil Classification		
				Group Symbol	Group Name ^B	
Coarse-Grained Soils: More than 50% retained on No. 200 sieve	Gravels: More than 50% of coarse fraction retained on No. 4 sieve	Clean Gravels: Less than 5% fines ^C	$Cu \geq 4$ and $1 \leq Cc \leq 3$ ^E	GW	Well-graded gravel ^F	
			$Cu < 4$ and/or $[Cc < 1 \text{ or } Cc > 3.0]$ ^E	GP	Poorly graded gravel ^F	
		Gravels with Fines: More than 12% fines ^C	Fines classify as ML or MH	GM	Silty gravel ^{F, G, H}	
			Fines classify as CL or CH	GC	Clayey gravel ^{F, G, H}	
	Sands: 50% or more of coarse fraction passes No. 4 sieve	Clean Sands: Less than 5% fines ^D	$Cu \geq 6$ and $1 \leq Cc \leq 3$ ^E	SW	Well-graded sand ^I	
			$Cu < 6$ and/or $[Cc < 1 \text{ or } Cc > 3.0]$ ^E	SP	Poorly graded sand ^I	
		Sands with Fines: More than 12% fines ^D	Fines classify as ML or MH	SM	Silty sand ^{G, H, I}	
			Fines classify as CL or CH	SC	Clayey sand ^{G, H, I}	
Fine-Grained Soils: 50% or more passes the No. 200 sieve	Silts and Clays: Liquid limit less than 50	Inorganic:	$PI > 7$ and plots on or above "A" line	CL	Lean clay ^{K, L, M}	
			$PI < 4$ or plots below "A" line ^J	ML	Silt ^{K, L, M}	
		Organic:	Liquid limit - oven dried	< 0.75	OL	Organic clay ^{K, L, M, N}
			Liquid limit - not dried			Organic silt ^{K, L, M, O}
	Silts and Clays: Liquid limit 50 or more	Inorganic:	PI plots on or above "A" line	CH	Fat clay ^{K, L, M}	
			PI plots below "A" line	MH	Elastic Silt ^{K, L, M}	
		Organic:	Liquid limit - oven dried	< 0.75	OH	Organic clay ^{K, L, M, P}
			Liquid limit - not dried			Organic silt ^{K, L, M, O}
Highly organic soils:	Primarily organic matter, dark in color, and organic odor			PT	Peat	

^A Based on the material passing the 3-inch (75-mm) sieve.

^B If field sample contained cobbles or boulders, or both, add "with cobbles or boulders, or both" to group name.

^C Gravels with 5 to 12% fines require dual symbols: GW-GM well-graded gravel with silt, GW-GC well-graded gravel with clay, GP-GM poorly graded gravel with silt, GP-GC poorly graded gravel with clay.

^D Sands with 5 to 12% fines require dual symbols: SW-SM well-graded sand with silt, SW-SC well-graded sand with clay, SP-SM poorly graded sand with silt, SP-SC poorly graded sand with clay.

$$E \quad Cu = D_{60}/D_{10} \quad Cc = \frac{(D_{30})^2}{D_{10} \times D_{60}}$$

^F If soil contains ³ 15% sand, add "with sand" to group name.

^G If fines classify as CL-ML, use dual symbol GC-GM, or SC-SM.

^H If fines are organic, add "with organic fines" to group name.

^I If soil contains ³ 15% gravel, add "with gravel" to group name.

^J If Atterberg limits plot in shaded area, soil is a CL-ML, silty clay.

^K If soil contains 15 to 29% plus No. 200, add "with sand" or "with gravel," whichever is predominant.

^L If soil contains ³ 30% plus No. 200 predominantly sand, add "sandy" to group name.

^M If soil contains ³ 30% plus No. 200, predominantly gravel, add "gravelly" to group name.

^N $PI \geq 4$ and plots on or above "A" line.

^O $PI < 4$ or plots below "A" line.

^P PI plots on or above "A" line.

^Q PI plots below "A" line.

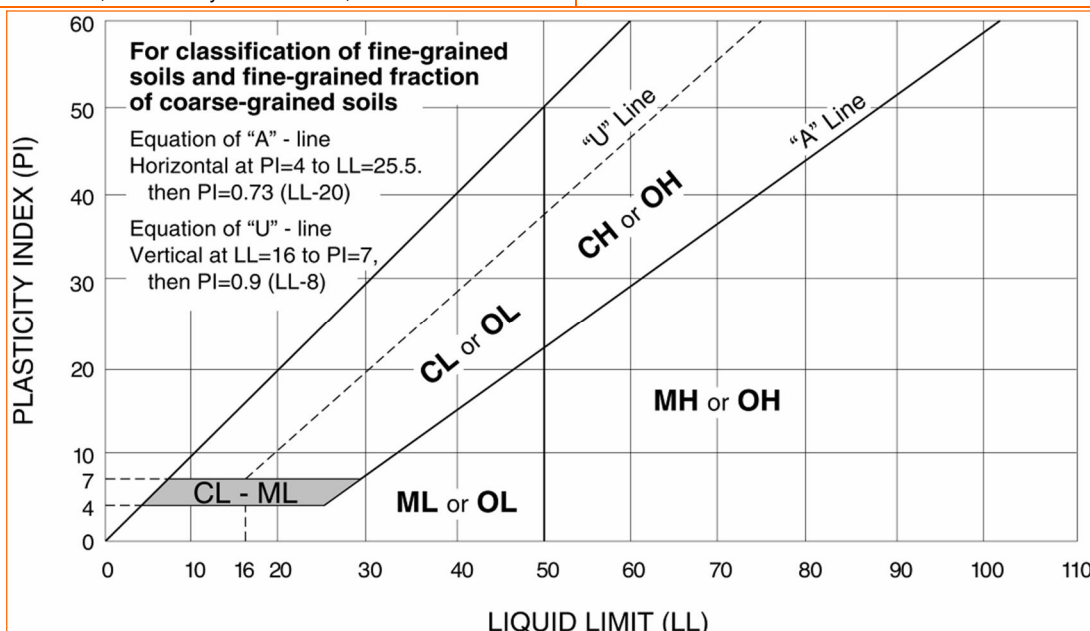

OPINION OF PROBABLE PROJECT COSTS



1/6/2023
OAK PARK BLVD SEWER REPLACEMENT
CITY OF CEDAR FALLS
 119.0115.08

ITEM NO.	ITEM CODE	ITEM	QUANTITY	UNIT	UNIT PRICE	EXTENDED PRICE
1	2010-C	Clearing and Grubbing	LS	1	\$ 5,000.00	\$ 5,000.00
2	2010-D-1	Topsoil, On-site	CY	190	\$ 13.00	\$ 2,470.00
3	2010-G	Subgrade Preparation	SY	276	\$ 2.00	\$ 552.00
4	2010-I	Subbase, 12" Modified	SY	191	\$ 16.00	\$ 3,056.00
5	2010-J-1	Removal of Structure	LS	1	\$ 20,000.00	\$ 20,000.00
6	2010-L	Compaction Testing	LS	1	\$ 6,000.00	\$ 6,000.00
7	3010-C	Trench Foundation	TON	18	\$ 26.00	\$ 468.00
8	3010-D	Replacement of Unsuitable Backfill Material	CY	119	\$ 31.00	\$ 3,689.00
9	3010-F	Trench Compaction Testing	LS	1	\$ 3,000.00	\$ 3,000.00
10	4010-A-1	Sanitary Sewer Gravity Main, Trenched, PVC,	LF	166	\$ 70.00	\$ 11,620.00
11	4010-C-1	Sanitary Sewer Force Main, Trenched, HDPE, 2"	LF	156	\$ 30.00	\$ 4,680.00
12	4010-C-2	Sanitary Sewer Force Main, Trenchless, HDPE, 2"	LF	300	\$ 75.00	\$ 22,500.00
13	4010-D-1	Sanitary Sewer Force Main with Casing Pipe,	LF	42	\$ 120.00	\$ 5,040.00
14	4010-E	Sanitary Sewer Service Stub, PVC, SDR 23.5, 4"	LF	24	\$ 100.00	\$ 2,400.00
15	4010-H	Removal of Sanitary Sewer, All Types and Sizes	LF	277	\$ 10.00	\$ 2,770.00
16	4010-I	Sanitary Sewer Cleanout	EA	2	\$ 2,400.00	\$ 4,800.00
17	4010-L	Sanitary Sewer Abandonment, Fill and Plug	LF	50	\$ 50.00	\$ 2,500.00
18	4020-A-1	Storm Sewer, Trenched, RCP, 15"	LF	20	\$ 80.00	\$ 1,600.00
19	4020-D	Removal of Storm Sewer, RCP, 15"	LF	20	\$ 60.00	\$ 1,200.00
20	4040-A	Subdrain, Type 1, 6"	LF	50	\$ 16.00	\$ 800.00
21	5010-A-1	Water Main, Trenched, DIP, 6"	LF	66	\$ 40.00	\$ 2,640.00
22	5010-C-1	Water Main Fittings, 6"	EA	4	\$ 400.00	\$ 1,600.00
23	5010-H	Water Main Removal, 6"	LF	51	\$ 51.00	\$ 2,601.00
24	6010-A	Manhole, SW-303, 48"	EA	1	\$ 5,000.00	\$ 5,000.00
25	6010-C-1	Internal Drop Connection	EA	1	\$ 1,000.00	\$ 1,000.00
26	6010-C-2	External Drop Connection	EA	1	\$ 1,000.00	\$ 1,000.00
27	6010-G	Connection to Existing Manhole	EA	1	\$ 1,500.00	\$ 1,500.00
28	6010-H	Remove Manhole	EA	2	\$ 2,000.00	\$ 4,000.00
29	7010-A	Pavement, PCC, 7"	SY	171	\$ 100.00	\$ 17,100.00
30	7021-A-0	HMA Overlay	TON	28.1	\$ 120.00	\$ 3,372.00
31	7030-A	Removal of Sidewalk	SY	61	\$ 10.00	\$ 610.00
32	7030-E	Sidewalk, PCC, 4"	SY	61	\$ 80.00	\$ 4,880.00
33	7030-H-1	Driveway, Paved, PCC, 6"	SY	46	\$ 60.00	\$ 2,760.00
34	7040-H	Pavement Removal	SY	216	\$ 20.00	\$ 4,320.00
35	8030-A	Temporary Traffic Control	LS	1	\$ 3,000.00	\$ 3,000.00
36	9010-B	Hydraulic Seeding, Seeding, Fertilizing, and	AC	0.24	\$ 5,000.00	\$ 1,200.00
37	9020-A	Sod	SQ	42	\$ 75.00	\$ 3,150.00
38	9030-D	Plants with Warranty	LS	1	\$ 2,945.00	\$ 2,945.00
39	9030-999-A	Mulch, Shredded Bark	SF	635	\$ 2.50	\$ 1,587.50
40	9030-999-B	Landscape Boulders	EA	5	\$ 350.00	\$ 1,750.00
41	9040-A-2	SWPPP Management	LS	1	\$ 2,000.00	\$ 2,000.00
42	9040-D-1	Filter Sock, 12"	LF	1,560	\$ 3.00	\$ 4,680.00
43	9040-D-2	Filter Sock, Removal	LF	1,560	\$ 1.00	\$ 1,560.00
44	9040-E-0	Temporary RECP, Type 4	SY	245	\$ 2.50	\$ 612.50
45	9040-O-1	Stabilized Construction Entrance	SY	94	\$ 9.00	\$ 846.00
46	9040-T-1	Inlet Protection Device, Filter Sock	EA	2	\$ 70.00	\$ 140.00
47	9040-T-2	Inlet Protection Device, Maintenance	EA	2	\$ 70.00	\$ 140.00
48	9999-A	Lift Station Column	LS	1	\$ 25,000.00	\$ 25,000.00
49	11,020-A	Mobilization	LS	1	\$ 36,512.00	\$ 36,512.00
50	11,050-A	Concrete Washout	LS	1	\$ 1,000.00	\$ 1,000.00
51	260000-01	Electrical	LS	1	\$ 10,000.00	\$ 10,000.00
52	333200-01	Lift Station, Complete	LS	1	\$ 148,981.00	\$ 148,981.00
					SUBTOTAL (ROUNDED):	\$ 402,000.00
					CONTINGENCY 10%	\$ 40,200.00
					TOTAL	\$ 442,200.00

DAILY INVOICES FOR 01/17/2023 COUNCIL MEETING

Item 24.

PREPARED 01/10/2023, 10:15:33
 PROGRAM GM360L
 CITY OF CEDAR FALLS

ACCOUNT ACTIVITY LISTING

PAGE 1
 ACCOUNTING PERIOD 06/2023

GROUP NBR	PO NBR	ACCTG PER.	CD	DATE	---TRANSACTION--- NUMBER	DESCRIPTION	DEBITS	CREDITS	CURRENT BALANCE	POST DT
FUND 101 GENERAL FUND										
101-0000-213.00-00 CURRENT LIABILITY / SALES TAX PAYABLE										
1015		06/23 AP		12/08/22	0006593	IOWA DEPT.OF REVENUE RECREATION	2,535.21			01/03/23
						MONTHLY SALES TAX				
						ACCOUNT TOTAL	2,535.21	.00	2,535.21	
101-1008-441.72-99 OPERATING SUPPLIES / POSTAGE										
1125		07/23 AP		01/04/23	0398117	CMRS-POC	117.30			01/09/23
						POC#8031880-REPL.POSTAGE 10/12/22-01/04/23				
						ACCOUNT TOTAL	117.30	.00	117.30	
101-1028-441.64-02 INSURANCE / HEALTH INS. REIMBURSEMENT										
1015		06/23 AP		12/13/22	0006598	ISOLVED BENEFIT SERVICES, INC	.81			01/03/23
						HEALTH INS. REIMBURSEMENT				
						ACCOUNT TOTAL	.81	.00	.81	
101-1028-441.72-99 OPERATING SUPPLIES / POSTAGE										
1125		07/23 AP		01/04/23	0398117	CMRS-POC	254.29			01/09/23
						POC#8031880-REPL.POSTAGE 10/12/22-01/04/23				
						ACCOUNT TOTAL	254.29	.00	254.29	
101-1028-441.89-17 MISCELLANEOUS SERVICES / BANK SERVICE CHARGES										
1015		06/23 AP		12/30/22	0006591	FARMERS STATE BANK	12.00			01/03/23
						INCOMING WIRE FEE MIDWEST CD				
1015		06/23 AP		12/30/22	0006592	FARMERS STATE BANK	12.00			01/03/23
						INCOMING WIRE FEE VERIDIAN CD				
1015		06/23 AP		12/28/22	0006590	FARMERS STATE BANK	20.00			01/03/23
						VOYA OUTGOING WIRE FEE 12/30/22 PAYROLL				
1082		07/23 AP		12/19/22	0398083	VERIZON WIRELESS	25.00			01/03/23
						RETURN CHECK FEE:OCT'2020				
1015		06/23 AP		12/14/22	0006589	FARMERS STATE BANK	20.00			01/03/23
						VOYA OUTGOING WIRE 12/16/22 PAYROLL				
						ACCOUNT TOTAL	89.00	.00	89.00	
101-1038-441.64-02 INSURANCE / HEALTH INS. REIMBURSEMENT										
1015		06/23 AP		12/13/22	0006598	ISOLVED BENEFIT SERVICES, INC	63.98			01/03/23
						HEALTH INS. REIMBURSEMENT				
						ACCOUNT TOTAL	63.98	.00	63.98	

PREPARED 01/10/2023, 10:15:33
 PROGRAM GM360L
 CITY OF CEDAR FALLS

ACCOUNT ACTIVITY LISTING

PAGE 2
 ACCOUNTING PERIOD 06/2023

GROUP NBR	PO NBR	ACCTG PER.	CD	DATE	TRANSACTION NUMBER	DESCRIPTION	DEBITS	CREDITS	CURRENT BALANCE	POST DT
FUND 101 GENERAL FUND										
101-1038-441.72-99						OPERATING SUPPLIES / POSTAGE				
1125	07/23	AP	01/04/23	0398117		CMRS-POC	467.12		01/09/23	
						POC#8031880-REPL.POSTAGE				10/12/22-01/04/23
						ACCOUNT TOTAL	467.12	.00	467.12	
101-1038-441.81-09 PROFESSIONAL SERVICES / HUMAN RIGHTS COMMISSION										
1125	07/23	AP	01/04/23	0398117		CMRS-POC	1.14		01/09/23	
						POC#8031880-REPL.POSTAGE				10/12/22-01/04/23
						ACCOUNT TOTAL	1.14	.00	1.14	
101-1038-441.81-32 PROFESSIONAL SERVICES / TUITION ASSISTANCE										
1125	07/23	AP	12/30/22	0398113		BARRON, CARSON	2,079.15		01/09/23	
						TUITION REIMBURSEMENT				ADMIN.BEHAV./PUB.BDGT.FIN
						ACCOUNT TOTAL	2,079.15	.00	2,079.15	
101-1038-441.89-82 MISCELLANEOUS SERVICES / SECTION 105										
1015	06/23	AP	12/06/22	0006597		ISOLVED BENEFIT SERVICES, INC	710.70		01/03/23	
						CAFE ADMIN FEE-NOV'22				
						ACCOUNT TOTAL	710.70	.00	710.70	
101-1048-441.71-01 OFFICE SUPPLIES / OFFICE SUPPLIES										
1125	07/23	AP	01/04/23	0398117		CMRS-POC	16.11		01/09/23	
						POC#8031880-REPL.POSTAGE				10/12/22-01/04/23
						ACCOUNT TOTAL	16.11	.00	16.11	
101-1060-423.71-01 OFFICE SUPPLIES / OFFICE SUPPLIES										
994	07/23	AP	12/16/22	0398109		OFFICE EXPRESS OFFICE PRODUCT	116.91		12/29/22	
						AAA BATTERIES, REMOVABLE				TAPE, POSTAGE METER LABEL
879	07/23	AP	12/12/22	0398109		OFFICE EXPRESS OFFICE PRODUCT	265.14		12/29/22	
						AAA BATTERIES, LETTER SIZE				CARDSTOCK & COPY PAPER
879	07/23	AP	12/05/22	0398109		OFFICE EXPRESS OFFICE PRODUCT	73.39		12/29/22	
						SCOTCH PAINTERS &				REMOVABLE TAPE
879	07/23	AP	11/22/22	0398109		OFFICE EXPRESS OFFICE PRODUCT	82.26		12/29/22	
						AVERY REMOVABLE LABELS &				3X3" POP-UP STICKY NOTES
						ACCOUNT TOTAL	537.70	.00	537.70	
101-1060-423.72-99 OPERATING SUPPLIES / POSTAGE										
1125	07/23	AP	01/04/23	0398117		CMRS-POC	25.08		01/09/23	

PREPARED 01/10/2023, 10:15:33
 PROGRAM GM360L
 CITY OF CEDAR FALLS

ACCOUNT ACTIVITY LISTING

PAGE 3
 ACCOUNTING PERIOD 06/2023

GROUP NBR	PO NBR	ACCTG PER.	CD	DATE	---TRANSACTION--- NUMBER	DESCRIPTION	DEBITS	CREDITS	CURRENT BALANCE	POST DT
FUND 101 GENERAL FUND										
101-1060-423.72-99 OPERATING SUPPLIES / POSTAGE						continued				
					POC#8031880-REPL.POSTAGE	10/12/22-01/04/23				
994		07/23 AP		11/27/22	0398111	QUADIENET FINANCE USA, INC. POSTAGE	450.00			12/29/22
					ACCOUNT TOTAL		475.08	.00	475.08	
101-1060-423.81-91 PROFESSIONAL SERVICES / LICENSES & SERVICE CONTRT										
994		07/23 AP		12/12/22	0398102	GORDON FLESCH COMPANY INC COPIER CONTRACT	923.47			12/29/22
					ACCOUNT TOTAL		923.47	.00	923.47	
101-1060-423.83-06 TRANSPORTATION&EDUCATION / EDUCATION										
994		07/23 AP		12/21/22	0398105	IOWA LIBRARY ASSOCIATION	150.00			12/29/22
					ANHALT ILA RENEWAL					
994		07/23 AP		12/16/22	0398105	IOWA LIBRARY ASSOCIATION	150.00			12/29/22
					STUENKEL ILA RENEWAL					
994		07/23 AP		12/16/22	0398105	IOWA LIBRARY ASSOCIATION	95.00			12/29/22
					BLACKFORD ILA RENEWAL					
879		07/23 AP		12/14/22	0398105	IOWA LIBRARY ASSOCIATION	160.00			12/29/22
					HOSFORD ILA RENEWAL					
879		07/23 AP		12/01/22	0398104	IOWA FREEDOM OF INFORMATION C INFORMATION BOOKS FOR BOARD	38.75			12/29/22
					ACCOUNT TOTAL		593.75	.00	593.75	
101-1060-423.85-01 UTILITIES / UTILITIES										
879		07/23 AP		12/05/22	0398095	CEDAR FALLS UTILITIES LIBRARY UTILITIES	4,130.04			12/29/22
					ACCOUNT TOTAL		4,130.04	.00	4,130.04	
101-1060-423.86-01 REPAIR & MAINTENANCE / REPAIR & MAINTENANCE										
879		07/23 AP		12/09/22	0398089	ARAMARK	23.55			12/29/22
					LIBRARY MAT SERVICE					
1015		06/23 AP		12/02/22	0006614	PROFESSIONAL SOLUTIONS	58.68			01/03/23
					NOVEMBER CREDIT CARD FEES					
879		07/23 AP		11/25/22	0398089	ARAMARK	23.55			12/29/22
					LIBRARY MAT SERVICE					
					ACCOUNT TOTAL		105.78	.00	105.78	
101-1060-423.89-20 MISCELLANEOUS SERVICES / ADULT BOOKS										
994		07/23 AP		12/16/22	0398091	BAKER & TAYLOR BOOKS	16.52			12/29/22

PREPARED 01/10/2023, 10:15:33
PROGRAM GM360L
CITY OF CEDAR FALLS

ACCOUNT ACTIVITY LISTING

PAGE 4
ACCOUNTING PERIOD 06/2023

GROUP NBR	PO NBR	ACCTG PER.	CD	DATE	TRANSACTION NUMBER	DESCRIPTION	DEBITS	CREDITS	CURRENT BALANCE	POST DT
FUND 101 GENERAL FUND										
101-1060-423.89-20 MISCELLANEOUS SERVICES / ADULT BOOKS						continued				
994				07/23	AP 12/13/22 0398091	ADULT BOOKS (MEM HOGAN) BAKER & TAYLOR BOOKS	18.00			12/29/22
994				07/23	AP 12/13/22 0398091	ADULT BOOKS (MEM HOGAN) BAKER & TAYLOR BOOKS	260.47			12/29/22
879				07/23	AP 12/09/22 0398091	ADULT BOOKS (MEM KNEBEL) BAKER & TAYLOR BOOKS	73.11			12/29/22
879				07/23	AP 12/01/22 0398091	ADULT BOOKS (MEM HOGAN) BAKER & TAYLOR BOOKS	15.95			12/29/22
879				07/23	AP 11/30/22 0398091	ADULT BOOKS (MEM HOGAN) BAKER & TAYLOR BOOKS	41.57			12/29/22
879				07/23	AP 11/30/22 0398091	ADULT BOOKS (MEM HOGAN) BAKER & TAYLOR BOOKS	64.59			12/29/22
ACCOUNT TOTAL							490.21	.00	490.21	
101-1060-423.89-33 MISCELLANEOUS SERVICES / FRIENDS SUPPORTED PROGRAM										
994				07/23	AP 12/16/22 0398091	FOTL:ADULT-ADULT BOOKS BAKER & TAYLOR BOOKS	5.99			12/29/22
879				07/23	AP 12/06/22 0398091	FOTL:YA-YOUNG ADULT BOOKS BAKER & TAYLOR BOOKS	771.09			12/29/22
879				07/23	AP 12/01/22 0398091	FOTL:ADULT-ADULT BOOKS BAKER & TAYLOR BOOKS	19.76			12/29/22
994				07/23	AP 11/30/22 0398112	FOTL:YOUTH-INSTRUMENT WATERLOO-CEDAR FALLS SYMPHONY PETTING ZOO	100.00			12/29/22
ACCOUNT TOTAL							896.84	.00	896.84	
101-1060-423.89-34 MISCELLANEOUS SERVICES / ENDOWMENT SUPPORTED PROG.										
994				07/23	AP 12/09/22 0398103	BERG 2 RMB BRANDING-PHASE IFC STUDIOS	45,000.00			12/29/22
994				07/23	AP 11/21/22 0398107	BERG 2 RMB SLP '23-KIDS NY INTERNATIONAL CHILDREN'S F FLICKS SCREENINGS	950.00			12/29/22
ACCOUNT TOTAL							45,950.00	.00	45,950.00	
101-1061-423.71-11 OFFICE SUPPLIES / TECHNICAL PROCESSING SUPP										
879				07/23	AP 12/08/22 0398098	1/4" FILAMENT & 2" BOOK DEMCO, INC TAPES	242.57			12/29/22
879				07/23	AP 12/07/22 0398094	9 & 12" BOOK COVER ROLLS, BRODART CO. 6 X 9.5" BOOK COVERS	787.66			12/29/22
879				07/23	AP 12/06/22 0398093	2X2 RFID TAGS (20,000) BAYSCAN TECHNOLOGIES	3,027.20			12/29/22
879				07/23	AP 08/23/22 0398100	PLAYAWAY LANYARDS (X25) FINDAWAY WORLD LLC	86.91			12/29/22
ACCOUNT TOTAL							4,144.34	.00	4,144.34	

PREPARED 01/10/2023, 10:15:33
 PROGRAM GM360L
 CITY OF CEDAR FALLS

ACCOUNT ACTIVITY LISTING

PAGE 5
 ACCOUNTING PERIOD 06/2023

GROUP NBR	PO NBR	ACCTG PER.	CD	TRANSACTION DATE	DESCRIPTION NUMBER	DEBITS	CREDITS	CURRENT BALANCE	POST DT
FUND 101 GENERAL FUND									
101-1061-423.81-91					PROFESSIONAL SERVICES / LICENSES & SERVICE CONTRT				
879		07/23 AP		12/01/22	0398108 OCLC, INC.	779.19		12/29/22	
					CATALOG AND METADATA SUBSCRIPTION				
994		07/23 AP		12/01/22	0398099 ENVISIONWARE, INC	2,450.60		12/29/22	
					HARDWARE & SOFTWARE MAIN. AGREEMENT 3/1/23-2/29/24				
					ACCOUNT TOTAL	3,229.79	.00	3,229.79	
101-1061-423.89-20 MISCELLANEOUS SERVICES / ADULT BOOKS									
994		07/23 AP		12/16/22	0398091 BAKER & TAYLOR BOOKS	422.64		12/29/22	
					ADULT BOOKS				
994		07/23 AP		12/13/22	0398091 BAKER & TAYLOR BOOKS	43.67		12/29/22	
					ADULT BOOKS				
879		07/23 AP		12/09/22	0398091 BAKER & TAYLOR BOOKS	20.99		12/29/22	
					ADULT BOOKS				
879		07/23 AP		12/07/22	0398091 BAKER & TAYLOR BOOKS	217.75		12/29/22	
					ADULT BOOKS				
879		07/23 AP		12/06/22	0398091 BAKER & TAYLOR BOOKS	139.99		12/29/22	
					ADULT BOOKS				
879		07/23 AP		12/06/22	0398091 BAKER & TAYLOR BOOKS	74.25		12/29/22	
					3RD AGE BOOKS				
879		07/23 AP		12/01/22	0398091 BAKER & TAYLOR BOOKS	152.68		12/29/22	
					ADULT BOOKS				
879		07/23 AP		12/01/22	0398097 CENTER POINT LARGE PRINT	419.44		12/29/22	
					3RD AGE BOOKS				
879		07/23 AP		11/30/22	0398091 BAKER & TAYLOR BOOKS	159.43		12/29/22	
					ADULT BOOKS				
879		07/23 AP		11/30/22	0398091 BAKER & TAYLOR BOOKS	342.14		12/29/22	
					ADULT BOOKS				
					ACCOUNT TOTAL	1,992.98	.00	1,992.98	
101-1061-423.89-21 MISCELLANEOUS SERVICES / YOUNG ADULT BOOKS									
994		07/23 AP		12/16/22	0398091 BAKER & TAYLOR BOOKS	53.48		12/29/22	
					YOUNG ADULT BOOKS				
994		07/23 AP		12/13/22	0398091 BAKER & TAYLOR BOOKS	6.59		12/29/22	
					YOUNG ADULT BOOKS				
879		07/23 AP		12/07/22	0398091 BAKER & TAYLOR BOOKS	5.99		12/29/22	
					YOUNG ADULT BOOKS				
879		07/23 AP		12/07/22	0398091 BAKER & TAYLOR BOOKS	877.35		12/29/22	
					YOUNG ADULT BOOKS				
879		07/23 AP		12/06/22	0398091 BAKER & TAYLOR BOOKS	21.04		12/29/22	
					YOUNG ADULT BOOKS				
879		07/23 AP		12/01/22	0398091 BAKER & TAYLOR BOOKS	16.68		12/29/22	
					YOUNG ADULT BOOKS				
879		07/23 AP		11/30/22	0398091 BAKER & TAYLOR BOOKS	135.45		12/29/22	
					YOUNG ADULT BOOKS				
879		07/23 AP		11/30/22	0398091 BAKER & TAYLOR BOOKS	39.58		12/29/22	

PREPARED 01/10/2023, 10:15:33
PROGRAM GM360L
CITY OF CEDAR FALLS

ACCOUNT ACTIVITY LISTING

PAGE 6
ACCOUNTING PERIOD 06/2023

GROUP NBR	PO NBR	ACCTG PER.	CD	---TRANSACTION--- DATE	NUMBER	DESCRIPTION	DEBITS	CREDITS	CURRENT BALANCE	POST DT
FUND 101 GENERAL FUND										
101-1061-423.89-21 MISCELLANEOUS SERVICES / YOUNG ADULT BOOKS							continued			
YOUNG ADULT BOOKS										
ACCOUNT TOTAL							1,156.16	.00	1,156.16	
101-1061-423.89-22 MISCELLANEOUS SERVICES / YOUTH BOOKS										
994		07/23 AP		12/16/22	0398091	BAKER & TAYLOR BOOKS	113.99			12/29/22
YOUTH BOOKS										
994		07/23 AP		12/15/22	0398091	BAKER & TAYLOR BOOKS	768.86			12/29/22
YOUTH BOOKS										
994		07/23 AP		12/13/22	0398091	BAKER & TAYLOR BOOKS	38.32			12/29/22
YOUTH BOOKS										
879		07/23 AP		12/09/22	0398091	BAKER & TAYLOR BOOKS	32.77			12/29/22
YOUTH BOOKS										
879		07/23 AP		12/07/22	0398091	BAKER & TAYLOR BOOKS	49.79			12/29/22
YOUTH BOOKS										
879		07/23 AP		12/06/22	0398091	BAKER & TAYLOR BOOKS	1,017.44			12/29/22
YOUTH BOOKS										
879		07/23 AP		12/01/22	0398091	BAKER & TAYLOR BOOKS	119.81			12/29/22
YOUTH BOOKS										
879		07/23 AP		11/30/22	0398091	BAKER & TAYLOR BOOKS	81.79			12/29/22
YOUTH BOOKS										
879		07/23 AP		11/30/22	0398091	BAKER & TAYLOR BOOKS	69.81			12/29/22
YOUTH BOOKS										
879		07/23 AP		11/30/22	0398091	BAKER & TAYLOR BOOKS	877.46			12/29/22
YOUTH BOOKS										
ACCOUNT TOTAL							3,170.04	.00	3,170.04	
101-1061-423.89-23 MISCELLANEOUS SERVICES / LARGE PRINT BOOKS										
994		07/23 AP		12/14/22	0398096	CENGAGE LEARNING INC	26.59			12/29/22
LARGE PRINT BOOKS										
994		07/23 AP		12/13/22	0398096	CENGAGE LEARNING INC	20.99			12/29/22
LARGE PRINT BOOKS										
879		07/23 AP		12/07/22	0398096	CENGAGE LEARNING INC	53.88			12/29/22
LARGE PRINT BOOKS										
879		07/23 AP		12/02/22	0398096	CENGAGE LEARNING INC	22.39			12/29/22
LARGE PRINT BOOKS										
879		07/23 AP		12/01/22	0398091	BAKER & TAYLOR BOOKS	18.00			12/29/22
LARGE PRINT BOOKS										
879		07/23 AP		12/01/22	0398097	CENTER POINT LARGE PRINT	49.14			12/29/22
LARGE PRINT BOOKS										
879		07/23 AP		11/24/22	0398096	CENGAGE LEARNING INC	21.70			12/29/22
LARGE PRINT BOOKS										
879		07/23 AP		11/23/22	0398096	CENGAGE LEARNING INC	21.00			12/29/22
LARGE PRINT BOOKS										
ACCOUNT TOTAL							233.69	.00	233.69	

PREPARED 01/10/2023, 10:15:33
PROGRAM GM360L
CITY OF CEDAR FALLS

ACCOUNT ACTIVITY LISTING

PAGE 7
ACCOUNTING PERIOD 06/2023

GROUP	PO	ACCTG	---TRANSACTION---		DESCRIPTION	DEBITS	CREDITS	CURRENT	POST DT	
NBR	NBR	PER.	CD	DATE	NUMBER			BALANCE	---	
FUND 101 GENERAL FUND										
101-1061-423.89-24 MISCELLANEOUS SERVICES / ADULT AUDIO										
879		07/23 AP		12/06/22	0398091	22.00		12/29/22		
		3RD AGE CD BOOKS								
879		07/23 AP		12/06/22	0398100	71.24		12/29/22		
		ADULT PLAYAWAY AUDIO								
879		07/23 AP		12/02/22	0398092	11.88		12/29/22		
		ADULT CD MUSIC								
879		07/23 AP		11/30/22	0398091	8.24		12/29/22		
		ADULT CD BOOKS								
879		07/23 AP		11/30/22	0398092	59.40		12/29/22		
		ADULT CD MUSIC								
879		07/23 AP		11/30/22	0398100	322.45		12/29/22		
		ADULT PLAYAWAY AUDIO								
879		07/23 AP		11/26/22	0398100	262.46		12/29/22		
		ADULT PLAYAWAY AUDIO								
		ACCOUNT TOTAL					757.67	0.00	757.67	
101-1061-423.89-25 MISCELLANEOUS SERVICES / ADULT VIDEO										
994		07/23 AP		12/16/22	0398092	48.98		12/29/22		
		ADULT VIDEOS								
994		07/23 AP		12/13/22	0398092	13.99		12/29/22		
		ADULT VIDEOS								
879		07/23 AP		12/09/22	0398092	79.76		12/29/22		
		ADULT VIDEOS								
879		07/23 AP		12/05/22	0398092	20.99		12/29/22		
		ADULT VIDEOS								
879		07/23 AP		12/02/22	0398092	46.18		12/29/22		
		ADULT VIDEOS								
879		07/23 AP		12/02/22	0398092	33.55		12/29/22		
		ADULT VIDEOS								
879		07/23 AP		11/30/22	0398092	109.15		12/29/22		
		ADULT VIDEOS								
879		07/23 AP		11/15/22	0398092	34.96		12/29/22		
		ADULT VIDEOS								
		ACCOUNT TOTAL					387.56	0.00	387.56	
101-1061-423.89-29 MISCELLANEOUS SERVICES / NEWSPAPERS										
879		07/23 AP		12/06/22	0398101	452.40		12/29/22		
		THE GAZETTE 1 YEAR SUB.								
		ACCOUNT TOTAL					452.40	0.00	452.40	
101-1061-423.89-31 MISCELLANEOUS SERVICES / PERIODICALS										
879		07/23 AP		01/01/23	0398106	136.00		12/29/22		
		FY23 OLDER USED CAR GUIDE								
		J.D. POWER 1 YEAR SUBSCRIPTION								

PREPARED 01/10/2023, 10:15:33
PROGRAM GM360L
CITY OF CEDAR FALLS

ACCOUNT ACTIVITY LISTING

PAGE 8
ACCOUNTING PERIOD 06/2023

GROUP NBR	PO NBR	ACCTG PER.	CD	-----TRANSACTION----- DATE	NUMBER	DESCRIPTION	DEBITS	CREDITS	CURRENT BALANCE	POST DT
FUND 101 GENERAL FUND										
101-1061-423.89-31 MISCELLANEOUS SERVICES / PERIODICALS						continued				
ACCOUNT TOTAL							136.00	.00	136.00	
101-1061-423.89-35 MISCELLANEOUS SERVICES / YOUTH AUDIO										
994		07/23 AP		12/16/22	0398091	BAKER & TAYLOR BOOKS	36.84			12/29/22
YOUTH CD BOOKS										
879		07/23 AP		12/05/22	0398100	FINDAWAY WORLD LLC	63.19			12/29/22
YOUTH PLAYAWAY AUDIO										
879		07/23 AP		12/05/22	0398100	FINDAWAY WORLD LLC	53.18			12/29/22
YOUTH PLAYAWAY AUDIO										
ACCOUNT TOTAL							153.21	.00	153.21	
101-1061-423.89-36 MISCELLANEOUS SERVICES / YOUTH VIDEO										
879		07/23 AP		12/08/22	0398100	FINDAWAY WORLD LLC	769.20			12/29/22
YOUTH LAUNCHPADS										
ACCOUNT TOTAL							769.20	.00	769.20	
101-1061-423.89-37 MISCELLANEOUS SERVICES / YOUNG ADULT AUDIO										
994		07/23 AP		12/13/22	0398100	FINDAWAY WORLD LLC	214.46			12/29/22
YOUNG ADULT PLAYAWAY AUDIO										
ACCOUNT TOTAL							214.46	.00	214.46	
101-1061-423.89-38 MISCELLANEOUS SERVICES / YOUNG ADULT VIDEO										
879		07/23 AP		12/09/22	0398092	BAKER & TAYLOR ENTERTAINMENT	65.77			12/29/22
YOUNG ADULT VIDEOS										
ACCOUNT TOTAL							65.77	.00	65.77	
101-1061-423.89-42 MISCELLANEOUS SERVICES / ADULT E-MATERIALS										
994		07/23 AP		12/19/22	0398110	OVERDRIVE, INC.	175.49			12/29/22
ADULT E-BOOKS										
994		07/23 AP		12/19/22	0398110	OVERDRIVE, INC.	199.98			12/29/22
ADULT AUDIO BOOKS										
994		07/23 AP		12/19/22	0398110	OVERDRIVE, INC.	162.49			12/29/22
ADULT AUDIO BOOKS										
879		07/23 AP		12/06/22	0398110	OVERDRIVE, INC.	56.97			12/29/22
ADULT E-BOOKS										
879		07/23 AP		12/06/22	0398110	OVERDRIVE, INC.	357.07			12/29/22
ADULT AUDIO BOOKS										
879		07/23 AP		12/06/22	0398110	OVERDRIVE, INC.	69.99			12/29/22
ADULT AUDIO BOOKS										

GROUP NBR	PO NBR	ACCTG PER.	CD	DATE	TRANSACTION NUMBER	DESCRIPTION	DEBITS	CREDITS	CURRENT BALANCE	POST DT	
FUND 101 GENERAL FUND											
101-1061-423.89-42 MISCELLANEOUS SERVICES / ADULT E-MATERIALS						continued					
879		07/23 AP		12/06/22	0398110	OVERDRIVE, INC.	47.50			12/29/22	
		ADULT AUDIO BOOKS									
879		07/23 AP		12/06/22	0398110	OVERDRIVE, INC.	55.00			12/29/22	
		ADULT E-BOOKS									
879		07/23 AP		12/06/22	0398110	OVERDRIVE, INC.	81.75			12/29/22	
		ADULT AUDIO BOOKS									
879		07/23 AP		11/29/22	0398110	OVERDRIVE, INC.	69.99			12/29/22	
		ADULT AUDIO BOOKS									
879		07/23 AP		11/22/22	0398110	OVERDRIVE, INC.	95.00			12/29/22	
		ADULT AUDIO BOOKS									
		ACCOUNT TOTAL						1,371.23	.00		1,371.23
101-1118-441.72-99 OPERATING SUPPLIES / POSTAGE											
1125		07/23 AP		01/04/23	0398117	CMRS-POC	3.84			01/09/23	
		POC#8031880-REPL.POSTAGE 10/12/22-01/04/23									
		ACCOUNT TOTAL						3.84	.00		3.84
101-1158-441.71-01 OFFICE SUPPLIES / OFFICE SUPPLIES											
1125		07/23 AP		01/04/23	0398117	CMRS-POC	1.71			01/09/23	
		POC#8031880-REPL.POSTAGE 10/12/22-01/04/23									
		ACCOUNT TOTAL						1.71	.00		1.71
101-1199-421.31-10 HUMAN DEVELOPMENT GRANTS / GRANTS - CULTURAL SERVICE											
1125		07/23 AP		01/04/23	0398117	CMRS-POC	5.40			01/09/23	
		POC#8031880-REPL.POSTAGE 10/12/22-01/04/23									
		ACCOUNT TOTAL						5.40	.00		5.40
101-1199-441.81-03 PROFESSIONAL SERVICES / RECORDING FEES											
1125		07/23 AP		01/06/23	0398116	BLACK HAWK CO.RECORDER	52.00			01/09/23	
		RCD:RESOLUTION 23,022 OVERMAN NORTH-323 W. 2ND									
1125		07/23 AP		01/06/23	0398116	BLACK HAWK CO.RECORDER	52.00			01/09/23	
		RCD:RESOLUTION 23,023 MICHAEL BECKER-829 LILAC									
1101		07/23 AP		01/03/23	0398085	BLACK HAWK CO.RECORDER	7.00			01/05/23	
		RCD:LIEN RELEASE NNG LLC-130 N. COLLEGE ST									
1101		07/23 AP		01/03/23	0398085	BLACK HAWK CO.RECORDER	7.00			01/05/23	
		RCD:LIEN RELEASE NNG LLC-130 N. COLLEGE ST									
1101		07/23 AP		01/03/23	0398085	BLACK HAWK CO.RECORDER	7.00			01/05/23	
		RCD:LIEN RELEASE R. COYLE-2303 WASHINGTON									
1101		07/23 AP		01/03/23	0398085	BLACK HAWK CO.RECORDER	7.00			01/05/23	
		RCD:LIEN RELEASE JOHN NELSON-603 FIRESIDE									
1054		06/23 AP		12/27/22	0398057	BLACK HAWK CO.RECORDER	7.00			12/28/22	

PREPARED 01/10/2023, 10:15:33
PROGRAM GM360L
CITY OF CEDAR FALLS

ACCOUNT ACTIVITY LISTING

PAGE 10
ACCOUNTING PERIOD 06/2023

GROUP	PO	ACCTG	----	TRANSACTION----						
NBR	NBR	PER.	CD	DATE	NUMBER	DESCRIPTION	DEBITS	CREDITS	CURRENT	POST DT
										BALANCE

FUND 101 GENERAL FUND										
101-1199-441.81-03 PROFESSIONAL SERVICES / RECORDING FEES						continued				
		RCD:EASEMENT-CF UTILITIES				WEST VIKING RD PHASE V				
1054		06/23 AP 12/27/22 0398057				BLACK HAWK CO.RECORDER	52.00			12/28/22
		RCD:RESOLUTION 23,004				BASIL REPPAS-2722 COLLEGE				
1054		06/23 AP 12/27/22 0398057				BLACK HAWK CO.RECORDER	57.00			12/28/22
		RCD:RESOLUTION 23,005				BASIL REPPAS-2804 COLLEGE				
1054		06/23 AP 12/27/22 0398057				BLACK HAWK CO.RECORDER	57.00			12/28/22
		RCD:RESOLUTION 23,006				RUTH WALKER-2208 COVENTRY				
ACCOUNT TOTAL							305.00	.00		305.00
101-1199-441.89-13 MISCELLANEOUS SERVICES / CONTINGENCY										
1068		06/23 AP 12/20/22 0398071				CEDAR FALLS UTILITIES	55.87			12/30/22
		UTILITIES THRU 12/20/22								
1015		06/23 AP 12/02/22 0006604				PROFESSIONAL SOLUTIONS	29.44			01/03/23
		NOVEMBER CREDIT CARD FEES								
ACCOUNT TOTAL							85.31	.00		85.31
101-1199-441.89-14 MISCELLANEOUS SERVICES / REFUNDS										
1068		06/23 AP 12/28/22 0398077				TYLOR YANT	68.00			12/30/22
		REF:CC PROCESSING ISSUE				PERMIT#22-4891-PLUM				
1101		07/23 AP 12/28/22 0398087				TYLOR YANT	364.00			01/05/23
		REFUND PERMIT 22-0899REMO				4312 BLAIR RIDGE RD				
1101		07/23 AP 12/20/22 0398086				BRUSTKERN CONSTRUCTION LLC	342.00			01/05/23
		REF: DUPLICATE CC PAYMENT				PERMIT# 22-4790/4791-WIND				
ACCOUNT TOTAL							774.00	.00		774.00
101-2205-432.72-99 OPERATING SUPPLIES / POSTAGE										
1125		07/23 AP 01/04/23 0398117				CMRS-POC	1.38			01/09/23
		POC#8031880-REPL.POSTAGE				10/12/22-01/04/23				
ACCOUNT TOTAL							1.38	.00		1.38
101-2235-412.64-02 INSURANCE / HEALTH INS. REIMBURSEMENT										
1015		06/23 AP 12/13/22 0006598				ISOLVED BENEFIT SERVICES, INC	35.80			01/03/23
		HEALTH INS. REIMBURSEMENT								
1015		06/23 AP 12/13/22 0006598				ISOLVED BENEFIT SERVICES, INC	165.06			01/03/23
		HEALTH INS. REIMBURSEMENT								
1015		06/23 AP 12/13/22 0006598				ISOLVED BENEFIT SERVICES, INC	53.60			01/03/23
		HEALTH INS. REIMBURSEMENT								
ACCOUNT TOTAL							254.46	.00		254.46

PREPARED 01/10/2023, 10:15:33
 PROGRAM GM360L
 CITY OF CEDAR FALLS

ACCOUNT ACTIVITY LISTING

PAGE 11
 ACCOUNTING PERIOD 06/2023

GROUP	PO	ACCTG	----TRANSACTION----		DESCRIPTION	DEBITS	CREDITS	CURRENT	POST
NBR	NBR	PER.	CD	DATE	NUMBER			BALANCE	DT
FUND 101 GENERAL FUND									
101-2235-412.71-07					OFFICE SUPPLIES / CODE ENFORCEMENT SUPPLIES				
1125		07/23 AP		01/04/23	0398117 CMRS-POC	403.06			01/09/23
					POC#8031880-REPL.POSTAGE				10/12/22-01/04/23
					ACCOUNT TOTAL	403.06	.00	403.06	
101-2235-412.72-99					OPERATING SUPPLIES / POSTAGE				
1125		07/23 AP		01/04/23	0398117 CMRS-POC	193.03			01/09/23
					POC#8031880-REPL.POSTAGE				10/12/22-01/04/23
					ACCOUNT TOTAL	193.03	.00	193.03	
101-2235-412.89-15					MISCELLANEOUS SERVICES / CREDIT CARD CHARGES				
1015		06/23 AP		12/02/22	0006609 PROFESSIONAL SOLUTIONS	672.04			01/03/23
					NOVEMBER CREDIT CARD FEES				
1015		06/23 AP		12/02/22	0006610 PROFESSIONAL SOLUTIONS	205.18			01/03/23
					NOVEMBER CREDIT CARD FEES				
					ACCOUNT TOTAL	877.22	.00	877.22	
101-2245-442.72-99					OPERATING SUPPLIES / POSTAGE				
1125		07/23 AP		01/04/23	0398117 CMRS-POC	312.80			01/09/23
					POC#8031880-REPL.POSTAGE				10/12/22-01/04/23
					ACCOUNT TOTAL	312.80	.00	312.80	
101-2253-423.71-01					OFFICE SUPPLIES / OFFICE SUPPLIES				
1125		07/23 AP		01/04/23	0398117 CMRS-POC	133.38			01/09/23
					POC#8031880-REPL.POSTAGE				10/12/22-01/04/23
					ACCOUNT TOTAL	133.38	.00	133.38	
101-2253-423.85-01					UTILITIES / UTILITIES				
1068		06/23 AP		12/20/22	0398071 CEDAR FALLS UTILITIES	147.75			12/30/22
					UTILITIES THRU 12/20/22				
					ACCOUNT TOTAL	147.75	.00	147.75	
101-2253-423.89-15					MISCELLANEOUS SERVICES / CREDIT CARD CHARGES				
1015		06/23 AP		12/02/22	0006612 PROFESSIONAL SOLUTIONS	22.95			01/03/23
					NOVEMBER CREDIT CARD FEES				
1015		06/23 AP		12/02/22	0006613 PROFESSIONAL SOLUTIONS	22.95			01/03/23
					NOVEMBER CREDIT CARD FEES				
1015		06/23 AP		12/02/22	0006615 PROFESSIONAL SOLUTIONS	761.34			01/03/23

PREPARED 01/10/2023, 10:15:33
 PROGRAM GM360L
 CITY OF CEDAR FALLS

ACCOUNT ACTIVITY LISTING

PAGE 12
 ACCOUNTING PERIOD 06/2023

GROUP	PO	ACCTG	----	TRANSACTION	----				
NBR	NBR	PER.	CD	DATE	NUMBER	DESCRIPTION	DEBITS	CREDITS	CURRENT BALANCE
									POST DT
FUND 101 GENERAL FUND									
101-2253-423.89-15 MISCELLANEOUS SERVICES / CREDIT CARD CHARGES						continued			
NOVEMBER CREDIT CARD FEES									
1015		06/23 AP		12/02/22	0006605	PROFESSIONAL SOLUTIONS	46.92		01/03/23
NOVEMBER CREDIT CARD FEES									
ACCOUNT TOTAL							854.16	.00	854.16
101-2280-423.72-99 OPERATING SUPPLIES / POSTAGE									
1125		07/23 AP		01/04/23	0398117	CMRS-POC	100.53		01/09/23
POC#8031880-REPL.POSTAGE 10/12/22-01/04/23									
ACCOUNT TOTAL							100.53	.00	100.53
101-2280-423.83-05 TRANSPORTATION&EDUCATION / TRAVEL (FOOD/MILEAGE/LOD)									
1125		07/23 AP		01/05/23	0398119	HAIGH, ABBY	38.42		01/09/23
RMB:MILEAGE7/13/22-1/5/23									
1125		07/23 AP		01/04/23	0398121	HINES, MAGGIE	54.26		01/09/23
RMB:MILG.11/29/22-1/4/23									
ACCOUNT TOTAL							92.68	.00	92.68
101-2280-423.89-15 MISCELLANEOUS SERVICES / CREDIT CARD CHARGES									
1015		06/23 AP		12/08/22	0006580	CLOVER APP	12.66		01/03/23
MERCHANT SUBSCRIPTION FEE									
1015		06/23 AP		12/02/22	0006605	PROFESSIONAL SOLUTIONS	64.99		01/03/23
NOVEMBER CREDIT CARD FEES									
1015		06/23 AP		12/02/22	0006606	PROFESSIONAL SOLUTIONS	11.90		01/03/23
NOVEMBER CREDIT CARD FEES									
1015		06/23 AP		12/02/22	0006607	PROFESSIONAL SOLUTIONS	67.69		01/03/23
NOVEMBER CREDIT CARD FEES									
ACCOUNT TOTAL							157.24	.00	157.24
101-4511-414.64-02 INSURANCE / HEALTH INS. REIMBURSEMENT									
1015		06/23 AP		12/13/22	0006598	ISOLVED BENEFIT SERVICES, INC	6.53		01/03/23
HEALTH INS. REIMBURSEMENT									
ACCOUNT TOTAL							6.53	.00	6.53
101-4511-414.72-99 OPERATING SUPPLIES / POSTAGE									
1125		07/23 AP		01/04/23	0398117	CMRS-POC	348.89		01/09/23
POC#8031880-REPL.POSTAGE 10/12/22-01/04/23									
ACCOUNT TOTAL							348.89	.00	348.89

PREPARED 01/10/2023, 10:15:33
 PROGRAM GM360L
 CITY OF CEDAR FALLS

ACCOUNT ACTIVITY LISTING

PAGE 13
 ACCOUNTING PERIOD 06/2023

GROUP	PO	ACCTG	----	TRANSACTION----					
NBR	NBR	PER.	CD	DATE	NUMBER	DESCRIPTION	DEBITS	CREDITS	CURRENT BALANCE POST DT
FUND 101 GENERAL FUND									
101-4511-414.89-14						MISCELLANEOUS SERVICES / REFUNDS			
1082		07/23 AP		12/30/22	0398080	MARK LUDWIG	64.58		01/03/23
						REF: OCCUPANCY PERMIT 709 STATE STREET			
						ACCOUNT TOTAL	64.58	.00	64.58
101-5521-415.64-02						INSURANCE / HEALTH INS. REIMBURSEMENT			
1015		06/23 AP		12/13/22	0006598	ISOLVED BENEFIT SERVICES, INC	74.00		01/03/23
						HEALTH INS. REIMBURSEMENT			
1015		06/23 AP		12/13/22	0006598	ISOLVED BENEFIT SERVICES, INC	85.60		01/03/23
						HEALTH INS. REIMBURSEMENT			
						ACCOUNT TOTAL	159.60	.00	159.60
101-5521-415.72-01						OPERATING SUPPLIES / OPERATING SUPPLIES			
1068		06/23 AP		12/20/22	0398071	CEDAR FALLS UTILITIES	36.09		12/30/22
						UTILITIES THRU 12/20/22			
1015		06/23 AP		12/02/22	0006603	PROFESSIONAL SOLUTIONS	51.80		01/03/23
						NOVEMBER CREDIT CARD FEES			
						ACCOUNT TOTAL	87.89	.00	87.89
101-5521-415.72-20						OPERATING SUPPLIES / OFFICERS EQUIPMENT			
1082		07/23 AP		12/20/22	0398081	MARTINEZ, OMAR	45.15		01/03/23
						RMB:OPT.EQUP.-RADIO TACO HIGH SPEED GEAR			
						ACCOUNT TOTAL	45.15	.00	45.15
101-5521-415.72-99						OPERATING SUPPLIES / POSTAGE			
1125		07/23 AP		01/04/23	0398117	CMRS-POC	175.64		01/09/23
						POC#8031880-REPL.POSTAGE 10/12/22-01/04/23			
						ACCOUNT TOTAL	175.64	.00	175.64
101-5521-415.83-05						TRANSPORTATION&EDUCATION / TRAVEL (FOOD/MILEAGE/LOD)			
1054		06/23 AP		12/16/22	0398055	BARRON, CARSON	72.69		12/28/22
						RMB:MEALS-HIGH RISK EVENT CAMP DODGE			
						ACCOUNT TOTAL	72.69	.00	72.69
101-5521-415.89-40						MISCELLANEOUS SERVICES / UNIFORM ALLOWANCE			
1125		07/23 AP		01/02/23	0398120	HARRENSTEIN, JEFFREY	34.75		01/09/23
						RMB:UNIFORM ALLOWANCE TARGET			
1125		07/23 AP		12/27/22	0398114	BELLIS, RYAN	29.96		01/09/23

PREPARED 01/10/2023, 10:15:33
 PROGRAM GM360L
 CITY OF CEDAR FALLS

ACCOUNT ACTIVITY LISTING

PAGE 14
 ACCOUNTING PERIOD 06/2023

GROUP	PO	ACCTG	----	TRANSACTION----					
NBR	NBR	PER.	CD	DATE	NUMBER	DESCRIPTION	DEBITS	CREDITS	CURRENT BALANCE POST DT
FUND 101 GENERAL FUND									
101-5521-415.89-40						MISCELLANEOUS SERVICES / UNIFORM ALLOWANCE			continued
1125		RMB:UNIFORM ALLOWANCE				SCHHEELS			
	07/23	AP 12/21/22		0398113		BARRON, CARSON	106.99		01/09/23
1125		RMB:UNIFORM ALLOWANCE				SCHHEELS			
	07/23	AP 12/20/22		0398123		MARCOTTE, MIKE	160.46		01/09/23
1082		RMB:UNIFORM ALLOWANCE				SCHHEELS			
	07/23	AP 12/16/22		0398078		ABBOTT, MARISSA	186.71		01/03/23
1082		RMB:UNIFORM ALLOWANCE				SCHHEELS			
	07/23	AP 12/08/22		0398079		BAUMGARTNER, CHRISTIAN	176.55		01/03/23
1082		RMB:UNIFORM ALLOWANCE				5.11 TACTICAL			
	07/23	AP 11/21/22		0398078		ABBOTT, MARISSA	86.99		01/03/23
1101		RMB:UNIFORM ALLOWANCE				5.11 TACTICAL			
	07/23	AP 11/21/22		0398084		BARRON, CARSON	96.30		01/05/23
		RMB:UNIFORM ALLOWANCE				5.11 TACTICAL			
						ACCOUNT TOTAL	878.71	.00	878.71
101-6613-433.72-01						OPERATING SUPPLIES / OPERATING SUPPLIES			
1125		RMB:UNIFORM ALLOWANCE				CMRS-POC	1.71		01/09/23
	07/23	AP 01/04/23		0398117					
		POC#8031880-REPL.POSTAGE				10/12/22-01/04/23			
						ACCOUNT TOTAL	1.71	.00	1.71
101-6613-433.85-01						UTILITIES / UTILITIES			
1068		RMB:UNIFORM ALLOWANCE				CEDAR FALLS UTILITIES	757.47		12/30/22
	06/23	AP 12/20/22		0398071		UTILITIES THRU 12/20/22			
						ACCOUNT TOTAL	757.47	.00	757.47
101-6616-446.64-02						INSURANCE / HEALTH INS. REIMBURSEMENT			
1015		RMB:UNIFORM ALLOWANCE				ISOLVED BENEFIT SERVICES, INC	72.63		01/03/23
	06/23	AP 12/13/22		0006598		HEALTH INS. REIMBURSEMENT			
						ACCOUNT TOTAL	72.63	.00	72.63
101-6616-446.85-01						UTILITIES / UTILITIES			
1068		RMB:UNIFORM ALLOWANCE				CEDAR FALLS UTILITIES	328.70		12/30/22
	06/23	AP 12/20/22		0398071		UTILITIES THRU 12/20/22			
						ACCOUNT TOTAL	328.70	.00	328.70
101-6623-423.85-01						UTILITIES / UTILITIES			
1068		RMB:UNIFORM ALLOWANCE				CEDAR FALLS UTILITIES	1,624.61		12/30/22
	06/23	AP 12/20/22		0398071		UTILITIES THRU 12/20/22			
						ACCOUNT TOTAL	1,624.61	.00	1,624.61

PREPARED 01/10/2023, 10:15:33
 PROGRAM GM360L
 CITY OF CEDAR FALLS

ACCOUNT ACTIVITY LISTING

PAGE 16
 ACCOUNTING PERIOD 06/2023

GROUP	PO	ACCTG	----	TRANSACTION	----				
NBR	NBR	PER.	CD	DATE	NUMBER	DESCRIPTION	DEBITS	CREDITS	CURRENT BALANCE
									POST DT
FUND 206 STREET CONSTRUCTION FUND									
206-6637-436.72-56 OPERATING SUPPLIES / FLOOD CONTROL						continued			
UTILITIES THRU 12/20/22									
ACCOUNT TOTAL							128.65	.00	128.65
206-6637-436.72-99 OPERATING SUPPLIES / POSTAGE									
1125		07/23 AP		01/04/23	0398117	CMRS-POC	26.10		01/09/23
POC#8031880-REPL.POSTAGE						10/12/22-01/04/23			
ACCOUNT TOTAL							26.10	.00	26.10
206-6647-436.71-01 OFFICE SUPPLIES / OFFICE SUPPLIES									
1125		07/23 AP		01/04/23	0398117	CMRS-POC	13.11		01/09/23
POC#8031880-REPL.POSTAGE						10/12/22-01/04/23			
ACCOUNT TOTAL							13.11	.00	13.11
206-6647-436.85-01 UTILITIES / UTILITIES									
1068		06/23 AP		12/20/22	0398071	CEDAR FALLS UTILITIES	648.68		12/30/22
UTILITIES THRU 12/20/22									
ACCOUNT TOTAL							648.68	.00	648.68
FUND TOTAL							1,041.89	.00	1,041.89
FUND 215 HOSPITAL FUND									
FUND 216 POLICE BLOCK GRANT FUND									
FUND 217 SECTION 8 HOUSING FUND									
217-2214-432.72-99 OPERATING SUPPLIES / POSTAGE									
1125		07/23 AP		01/04/23	0039122	CMRS-POC	335.79		01/09/23
POC#8031880-REPL.POSTAGE						10/12/22-01/04/23			
ACCOUNT TOTAL							335.79	.00	335.79
217-2214-432.89-61 MISCELLANEOUS SERVICES / HOUS.ASSIST PMTS-OCCUPIED									
1067		07/23 AP		01/01/23	0039050	BAUCH, JAMES C	460.00		12/30/22
HAP_Lewis H 012023									
1067		07/23 AP		01/01/23	0039102	RINNELS, DOUGLAS G.	282.00		12/30/22
HAP_wierck L 012023									
1067		07/23 AP		01/01/23	0039058	CHESTNUT, SHAWN	489.00		12/30/22
HAP_Chestnut N 012023									
1067		07/23 AP		01/01/23	0039068	EXCEPTIONAL PERSONS, INC.	420.00		12/30/22
HAP_Blake M 012023									
1067		07/23 AP		01/01/23	0039068	EXCEPTIONAL PERSONS, INC.	115.00		12/30/22

PREPARED 01/10/2023, 10:15:33
PROGRAM GM360L
CITY OF CEDAR FALLS

ACCOUNT ACTIVITY LISTING

PAGE 17
ACCOUNTING PERIOD 06/2023

GROUP NBR	PO NBR	ACCTG PER.	CD	DATE	-----TRANSACTION----- NUMBER	DESCRIPTION	DEBITS	CREDITS	CURRENT BALANCE	POST DT
FUND 217 SECTION 8 HOUSING FUND										
217-2214-432.89-61 MISCELLANEOUS SERVICES / HOUS.ASSIST PMTS-OCCUPIED						continued				
1067		HAP Houdek C		07/23	AP 01/01/23 0039068	EXCEPTIONAL PERSONS, INC.	305.00		12/30/22	
1067		HAP Poldberg J		07/23	AP 01/01/23 0039068	EXCEPTIONAL PERSONS, INC.	412.00		12/30/22	
1067		HAP Myers J		07/23	AP 01/01/23 0039068	EXCEPTIONAL PERSONS, INC.	374.00		12/30/22	
1067		HAP Nissen A		07/23	AP 01/01/23 0039068	EXCEPTIONAL PERSONS, INC.	78.00		12/30/22	
1067		HAP Anderson B		07/23	AP 01/01/23 0039074	GOLD FALLS VILLA	455.00		12/30/22	
1067		HAP Shuman J		07/23	AP 01/01/23 0039071	GEELAN, JOSEPH N.	369.00		12/30/22	
1067		HAP Becker T		07/23	AP 01/01/23 0039071	GEELAN, JOSEPH N.	380.00		12/30/22	
1067		HAP Juhl A		07/23	AP 01/01/23 0039076	GRAY, LEROY L. OR CAROLYN K.	800.00		12/30/22	
1067		HAP Mullins J		07/23	AP 01/01/23 0039048	BARTELT PROPERTIES L.C.	509.00		12/30/22	
1067		HAP Luck L		07/23	AP 01/01/23 0039048	BARTELT PROPERTIES L.C.	553.00		12/30/22	
1067		HAP Woodward C		07/23	AP 01/01/23 0039048	BARTELT PROPERTIES L.C.	1,055.00		12/30/22	
1067		HAP Avino G		07/23	AP 01/01/23 0039065	EDGE MANAGEMENT GROUP, LLC	876.00		12/30/22	
1067		HAP Young C		07/23	AP 01/01/23 0039112	VALDIVIA, OSCAR J.	1,049.00		12/30/22	
1067		HAP Davis C		07/23	AP 01/01/23 0039061	COOK CO.HOUSING AUTHORITY	120.00		12/30/22	
1067		HAP Goldstein K		07/23	AP 01/01/23 0039115	WILKEN PROPERTIES, LLC	695.00		12/30/22	
1067		HAP Barfels K		07/23	AP 01/01/23 0039100	PURDY PROPERTIES, LLC	933.00		12/30/22	
1067		HAP Cummings A		07/23	AP 01/01/23 0039051	BETH N BROS LLC	808.00		12/30/22	
1067		HAP Beaman D		07/23	AP 01/01/23 0039063	D & J PROPERTIES	495.00		12/30/22	
1067		HAP Grant F		07/23	AP 01/01/23 0039063	D & J PROPERTIES	297.00		12/30/22	
1067		HAP Rogers S		07/23	AP 01/01/23 0039063	D & J PROPERTIES	773.00		12/30/22	
1067		HAP Terry M		07/23	AP 01/01/23 0039063	D & J PROPERTIES	464.00		12/30/22	
1067		HAP Redd S		07/23	AP 01/01/23 0039063	D & J PROPERTIES	599.00		12/30/22	
1067		HAP Sumerall T		07/23	AP 01/01/23 0039105	STANDARD FAMILY ASSIST.LIVING	248.00		12/30/22	
1067		HAP Refshauge T		07/23	AP 01/01/23 0039055	CEDAR APARTMENTS LLC	233.00		12/30/22	
		HAP Becerra C		01/2023						

PREPARED 01/10/2023, 10:15:33
 PROGRAM GM360L
 CITY OF CEDAR FALLS

ACCOUNT ACTIVITY LISTING

PAGE 18
 ACCOUNTING PERIOD 06/2023

GROUP NBR	PO NBR	ACCTG PER.	CD	TRANSACTION DATE	DESCRIPTION	DEBITS	CREDITS	CURRENT BALANCE	POST DT
FUND 217 SECTION 8 HOUSING FUND									
217-2214-432.89-61 MISCELLANEOUS SERVICES / HOUS.ASSIST PMTS-OCCUPIED						continued			
1067		07/23 AP		01/01/23 0039055	CEDAR APARTMENTS LLC	154.00		12/30/22	
		HAP_Groskurth D 012023							
1067		07/23 AP		01/01/23 0039108	SWEETING, LARRY	753.00		12/30/22	
		HAP_Schumacher D 012023							
1067		07/23 AP		01/01/23 0039111	THUNDER RIDGE SR.APARTMENTS L	439.00		12/30/22	
		HAP_Strickland L 012023							
1067		07/23 AP		01/01/23 0039111	THUNDER RIDGE SR.APARTMENTS L	215.00		12/30/22	
		HAP_Martin H 012023							
1067		07/23 AP		01/01/23 0039111	THUNDER RIDGE SR.APARTMENTS L	211.00		12/30/22	
		HAP_Matthias L 012023							
1067		07/23 AP		01/01/23 0039111	THUNDER RIDGE SR.APARTMENTS L	405.00		12/30/22	
		HAP_Lebahn B 012023							
1067		07/23 AP		01/01/23 0039111	THUNDER RIDGE SR.APARTMENTS L	503.00		12/30/22	
		HAP_Stegen R 012023							
1067		07/23 AP		01/01/23 0039111	THUNDER RIDGE SR.APARTMENTS L	193.00		12/30/22	
		HAP_Stock M 012023							
1067		07/23 AP		01/01/23 0039111	THUNDER RIDGE SR.APARTMENTS L	222.00		12/30/22	
		HAP_Wray M 012023							
1067		07/23 AP		01/01/23 0039111	THUNDER RIDGE SR.APARTMENTS L	436.00		12/30/22	
		HAP_Greene L 012023							
1067		07/23 AP		01/01/23 0039111	THUNDER RIDGE SR.APARTMENTS L	489.00		12/30/22	
		HAP_Howe J 012023							
1067		07/23 AP		01/01/23 0039111	THUNDER RIDGE SR.APARTMENTS L	396.00		12/30/22	
		HAP_Hayden J 012023							
1067		07/23 AP		01/01/23 0039111	THUNDER RIDGE SR.APARTMENTS L	29.00		12/30/22	
		HAP_Lenz J 012023							
1067		07/23 AP		01/01/23 0039111	THUNDER RIDGE SR.APARTMENTS L	346.00		12/30/22	
		HAP_Shelton S 012023							
1067		07/23 AP		01/01/23 0039111	THUNDER RIDGE SR.APARTMENTS L	105.00		12/30/22	
		HAP_Brown J 012023							
1067		07/23 AP		01/01/23 0039111	THUNDER RIDGE SR.APARTMENTS L	143.00		12/30/22	
		HAP_Garvis C 012023							
1067		07/23 AP		01/01/23 0039111	THUNDER RIDGE SR.APARTMENTS L	251.00		12/30/22	
		HAP_Wright S 012023							
1067		07/23 AP		01/01/23 0039111	THUNDER RIDGE SR.APARTMENTS L	426.00		12/30/22	
		HAP_Wright S 012023							
1067		07/23 AP		01/01/23 0039111	THUNDER RIDGE SR.APARTMENTS L	525.00		12/30/22	
		HAP_Graves D 012023							
1067		07/23 AP		01/01/23 0039111	THUNDER RIDGE SR.APARTMENTS L	182.00		12/30/22	
		HAP_Ford M 012023							
1067		07/23 AP		01/01/23 0039111	THUNDER RIDGE SR.APARTMENTS L	518.00		12/30/22	
		HAP_Henning S 012023							
1067		07/23 AP		01/01/23 0039111	THUNDER RIDGE SR.APARTMENTS L	481.00		12/30/22	
		HAP_Turner S 012023							
1067		07/23 AP		01/01/23 0039111	THUNDER RIDGE SR.APARTMENTS L	391.00		12/30/22	
		HAP_Mackie N 012023							
1067		07/23 AP		01/01/23 0039111	THUNDER RIDGE SR.APARTMENTS L	166.00		12/30/22	
		HAP_Friedrich D 012023							
1067		07/23 AP		01/01/23 0039113	VILLAGE I AT NINE23 APARTMENT	232.00		12/30/22	

PREPARED 01/10/2023, 10:15:33
 PROGRAM GM360L
 CITY OF CEDAR FALLS

ACCOUNT ACTIVITY LISTING

PAGE 19
 ACCOUNTING PERIOD 06/2023

GROUP NBR	PO NBR	ACCTG PER.	CD	DATE	TRANSACTION NUMBER	DESCRIPTION	DEBITS	CREDITS	CURRENT BALANCE	POST DT
FUND 217 SECTION 8 HOUSING FUND										
217-2214-432.89-61 MISCELLANEOUS SERVICES / HOUS.ASSIST PMTS-OCCUPIED continued										
1067				07/23	AP 01/01/23 0039113	HAP Havlik C 012023 VILLAGE I AT NINE23 APARTMENT	427.00			12/30/22
1067				07/23	AP 01/01/23 0039113	HAP Temple S 012023 VILLAGE I AT NINE23 APARTMENT	430.00			12/30/22
1067				07/23	AP 01/01/23 0039113	HAP Gordon Jr. T 012023 VILLAGE I AT NINE23 APARTMENT	254.00			12/30/22
1067				07/23	AP 01/01/23 0039113	HAP Aswegan J 012023 VILLAGE I AT NINE23 APARTMENT	237.00			12/30/22
1067				07/23	AP 01/01/23 0039113	HAP Vaughn S 012023 VILLAGE I AT NINE23 APARTMENT	455.00			12/30/22
1067				07/23	AP 01/01/23 0039113	HAP Redd A 012023 VILLAGE I AT NINE23 APARTMENT	506.00			12/30/22
1067				07/23	AP 01/01/23 0039113	HAP Smith T 012023 VILLAGE I AT NINE23 APARTMENT	453.00			12/30/22
1067				07/23	AP 01/01/23 0039113	HAP Nelson B 012023 VILLAGE I AT NINE23 APARTMENT	569.00			12/30/22
1067				07/23	AP 01/01/23 0039113	HAP Fry S 012023 VILLAGE I AT NINE23 APARTMENT	289.00			12/30/22
1067				07/23	AP 01/01/23 0039113	HAP Ford D 012023 VILLAGE I AT NINE23 APARTMENT	430.00			12/30/22
1067				07/23	AP 01/01/23 0039113	HAP Smith W 012023 VILLAGE I AT NINE23 APARTMENT	569.00			12/30/22
1067				07/23	AP 01/01/23 0039113	HAP Ducharme T 012023 VILLAGE I AT NINE23 APARTMENT	461.00			12/30/22
1067				07/23	AP 01/01/23 0039113	HAP Swartley J 012023 VILLAGE I AT NINE23 APARTMENT	489.00			12/30/22
1067				07/23	AP 01/01/23 0039113	HAP Prior L 012023 VILLAGE I AT NINE23 APARTMENT	406.00			12/30/22
1067				07/23	AP 01/01/23 0039113	HAP Aswegan S 012023 VILLAGE I AT NINE23 APARTMENT	524.00			12/30/22
1067				07/23	AP 01/01/23 0039113	HAP Henderson D 012023 VILLAGE I AT NINE23 APARTMENT	374.00			12/30/22
1067				07/23	AP 01/01/23 0039113	HAP Cameron J 012023 VILLAGE I AT NINE23 APARTMENT	435.00			12/30/22
1067				07/23	AP 01/01/23 0039113	HAP Clark T 012023 VILLAGE I AT NINE23 APARTMENT	461.00			12/30/22
1067				07/23	AP 01/01/23 0039113	HAP Moore D 012023 VILLAGE I AT NINE23 APARTMENT	271.00			12/30/22
1067				07/23	AP 01/01/23 0039113	HAP Harper S 012023 VILLAGE I AT NINE23 APARTMENT	338.00			12/30/22
1067				07/23	AP 01/01/23 0039113	HAP Greene D 012023 VILLAGE I AT NINE23 APARTMENT	220.00			12/30/22
1067				07/23	AP 01/01/23 0039113	HAP Bradley J 012023 VILLAGE I AT NINE23 APARTMENT	217.00			12/30/22
1067				07/23	AP 01/01/23 0039113	HAP Porter J 012023 VILLAGE I AT NINE23 APARTMENT	171.00			12/30/22
1067				07/23	AP 01/01/23 0039056	HAP Dixon S 012023 CEDAR FALLS UTILITIES-SEC.8	54.00			12/30/22
BRINER 6898932426										

PREPARED 01/10/2023, 10:15:33
 PROGRAM GM360L
 CITY OF CEDAR FALLS

ACCOUNT ACTIVITY LISTING

PAGE 20
 ACCOUNTING PERIOD 06/2023

GROUP NBR	PO NBR	ACCTG PER.	CD	TRANSACTION DATE	NUMBER	DESCRIPTION	DEBITS	CREDITS	CURRENT BALANCE	POST DT
FUND 217 SECTION 8 HOUSING FUND										
217-2214-432.89-61 MISCELLANEOUS SERVICES / HOUS.ASSIST PMTS-OCCUPIED						continued				
1067		07/23 AP		01/01/23	0039056	CEDAR FALLS UTILITIES-SEC.8	26.00			12/30/22
		Lowe 8726127079								
1067		07/23 AP		01/01/23	0039056	CEDAR FALLS UTILITIES-SEC.8	36.00			12/30/22
		Prior 5694286669								
1067		07/23 AP		01/01/23	0039056	CEDAR FALLS UTILITIES-SEC.8	155.00			12/30/22
		Bracelly 9823574708								
1067		07/23 AP		01/01/23	0039056	CEDAR FALLS UTILITIES-SEC.8	127.00			12/30/22
		Boehmer 0827605626								
1067		07/23 AP		01/01/23	0039056	CEDAR FALLS UTILITIES-SEC.8	78.00			12/30/22
		BALM 4535924167								
1067		07/23 AP		01/01/23	0039056	CEDAR FALLS UTILITIES-SEC.8	21.00			12/30/22
		Guzzle 7174748062								
1067		07/23 AP		01/01/23	0039056	CEDAR FALLS UTILITIES-SEC.8	43.00			12/30/22
		Jurries 7681775462								
1067		07/23 AP		01/01/23	0039056	CEDAR FALLS UTILITIES-SEC.8	69.00			12/30/22
		Rule 9816666531								
1067		07/23 AP		01/01/23	0039056	CEDAR FALLS UTILITIES-SEC.8	30.00			12/30/22
		Holden 1780239031								
1067		07/23 AP		01/01/23	0039056	CEDAR FALLS UTILITIES-SEC.8	72.00			12/30/22
		Mullins 9837918987								
1067		07/23 AP		01/01/23	0039092	MALBEC PROPERTIES, LLC	474.00			12/30/22
		HAP Hepker D 012023								
1067		07/23 AP		01/01/23	0039092	MALBEC PROPERTIES, LLC	275.00			12/30/22
		HAP Stevens B 012023								
1067		07/23 AP		01/01/23	0039092	MALBEC PROPERTIES, LLC	478.00			12/30/22
		HAP Halterman A 012023								
1067		07/23 AP		01/01/23	0039092	MALBEC PROPERTIES, LLC	442.00			12/30/22
		HAP Himes G 012023								
1067		07/23 AP		01/01/23	0039092	MALBEC PROPERTIES, LLC	362.00			12/30/22
		HAP Smith T 012023								
1067		07/23 AP		01/01/23	0039059	CHRISTOPHERSON RENTALS	631.00			12/30/22
		HAP Ricks F 012023								
1067		07/23 AP		01/01/23	0039059	CHRISTOPHERSON RENTALS	81.00			12/30/22
		HAP Hall T 012023								
1067		07/23 AP		01/01/23	0039059	CHRISTOPHERSON RENTALS	335.00			12/30/22
		HAP Ross Z 012023								
1067		07/23 AP		01/01/23	0039059	CHRISTOPHERSON RENTALS	46.00			12/30/22
		HAP Schwaab A 012023								
1067		07/23 AP		01/01/23	0039059	CHRISTOPHERSON RENTALS	196.00			12/30/22
		HAP Sherwood S 012023								
1067		07/23 AP		01/01/23	0039059	CHRISTOPHERSON RENTALS	779.00			12/30/22
		HAP Hoffert J 012023								
1067		07/23 AP		01/01/23	0039059	CHRISTOPHERSON RENTALS	667.00			12/30/22
		HAP Dyer A 012023								
1067		07/23 AP		01/01/23	0039059	CHRISTOPHERSON RENTALS	344.00			12/30/22
		HAP Davis K 012023								
1067		07/23 AP		01/01/23	0039059	CHRISTOPHERSON RENTALS	67.00			12/30/22
		HAP Keys A 012023								
1067		07/23 AP		01/01/23	0039059	CHRISTOPHERSON RENTALS	575.00			12/30/22

PREPARED 01/10/2023, 10:15:33
PROGRAM GM360L
CITY OF CEDAR FALLS

ACCOUNT ACTIVITY LISTING

PAGE 21
ACCOUNTING PERIOD 06/2023

GROUP NBR	PO NBR	ACCTG PER.	CD	DATE	TRANSACTION NUMBER	DESCRIPTION	DEBITS	CREDITS	CURRENT BALANCE	POST DT
FUND 217 SECTION 8 HOUSING FUND										
217-2214-432.89-61 MISCELLANEOUS SERVICES / HOUS.ASSIST PMTS-OCCUPIED						continued				
					HAP_Hunt M 012023					
1067				07/23	AP 01/01/23 0039099	PETERSEN, RANDEL	904.00		12/30/22	
					HAP_Brown S 012023					
1067				07/23	AP 01/01/23 0039095	MHP 2216 LINCOLN STREET, LLC	336.00		12/30/22	
					HAP_Cochran S 012023					
1067				07/23	AP 01/01/23 0039095	MHP 2216 LINCOLN STREET, LLC	350.00		12/30/22	
					HAP_Jones T 012023					
1067				07/23	AP 01/01/23 0039095	MHP 2216 LINCOLN STREET, LLC	464.00		12/30/22	
					HAP_Wilder S 012023					
1067				07/23	AP 01/01/23 0039095	MHP 2216 LINCOLN STREET, LLC	595.00		12/30/22	
					HAP_Rule S 012023					
1067				07/23	AP 01/01/23 0039073	GLEESON II, JAMES G.	800.00		12/30/22	
					HAP_Prior D 012023					
1067				07/23	AP 01/01/23 0039067	EPM IOWA	411.00		12/30/22	
					HAP_Frisch K 012023					
1067				07/23	AP 01/01/23 0039067	EPM IOWA	652.00		12/30/22	
					HAP_Thompson T 012023					
1067				07/23	AP 01/01/23 0039064	DC MANAGEMENT, LLC	730.00		12/30/22	
					HAP_Strickland S 012023					
1067				07/23	AP 01/01/23 0039091	LEGACY RESIDENTIAL	179.00		12/30/22	
					HAP_Jordan L 012023					
1067				07/23	AP 01/01/23 0039097	OWL INVESTMENTS, LLC	626.00		12/30/22	
					HAP_Schroeder S 012023					
1067				07/23	AP 01/01/23 0039062	CRESCENT CONDOMINIUMS, LLC	494.00		12/30/22	
					HAP_Lohr K 012023					
1067				07/23	AP 01/01/23 0039078	HARRINGTON'S RENTAL LLC	544.00		12/30/22	
					HAP_Larronda E 012023					
1067				07/23	AP 01/01/23 0039069	FERNHOLZ, KARI L.	794.00		12/30/22	
					HAP_Carlton D 012023					
1067				07/23	AP 01/01/23 0039103	ROGERS, DERICK	825.00		12/30/22	
					HAP_Sherwood J 012023					
1067				07/23	AP 01/01/23 0039103	ROGERS, DERICK	1,200.00		12/30/22	
					HAP_Santiago-Lebro 012023					
1067				07/23	AP 01/01/23 0039084	KAI, BRENT	251.00		12/30/22	
					HAP_Hamilton T 012023					
1067				07/23	AP 01/01/23 0039104	STAND FIRM PROPERTIES LLC	559.00		12/30/22	
					HAP_Rousseau G 012023					
1067				07/23	AP 01/01/23 0039104	STAND FIRM PROPERTIES LLC	380.00		12/30/22	
					HAP_Hodge G 012023					
1067				07/23	AP 01/01/23 0039118	WYMORE, LARRY R.	341.00		12/30/22	
					HAP_MOFFETT J 012023					
1067				07/23	AP 01/01/23 0039117	WINGSB, LLC	358.00		12/30/22	
					HAP_Johnson A 012023					
1067				07/23	AP 01/01/23 0039083	JLL EXTENDED STAY INN	203.00		12/30/22	
					HAP_Zanders D 012023					
1067				07/23	AP 01/01/23 0039083	JLL EXTENDED STAY INN	328.00		12/30/22	
					HAP_Moore E 012023					
1067				07/23	AP 01/01/23 0039090	LARSEN RENTALS LLC	142.00		12/30/22	
					HAP_Grisby C 012023					

GROUP NBR	PO NBR	ACCTG PER.	CD	DATE	TRANSACTION NUMBER	DESCRIPTION	DEBITS	CREDITS	CURRENT BALANCE	POST DT	
FUND 217 SECTION 8 HOUSING FUND											
217-2214-432.89-61 MISCELLANEOUS SERVICES / HOUS.ASSIST PMTS-OCCUPIED											
1067		07/23 AP		01/01/23	0039114	VILLAGE II AT NINE23 APARTMEN	319.00		12/30/22		
							continued				
		HAP Saccento J 012023									
1067		07/23 AP		01/01/23	0039114	VILLAGE II AT NINE23 APARTMEN	461.00		12/30/22		
		HAP Harken G 012023									
1067		07/23 AP		01/01/23	0039114	VILLAGE II AT NINE23 APARTMEN	328.00		12/30/22		
		HAP Dzapo S 012023									
1067		07/23 AP		01/01/23	0039114	VILLAGE II AT NINE23 APARTMEN	333.00		12/30/22		
		HAP Harmon A 012023									
1067		07/23 AP		01/01/23	0039114	VILLAGE II AT NINE23 APARTMEN	703.00		12/30/22		
		HAP Miller K 012023									
1067		07/23 AP		01/01/23	0039114	VILLAGE II AT NINE23 APARTMEN	435.00		12/30/22		
		HAP Haug K 012023									
1067		07/23 AP		01/01/23	0039114	VILLAGE II AT NINE23 APARTMEN	436.00		12/30/22		
		HAP Loffredo C 012023									
1067		07/23 AP		01/01/23	0039114	VILLAGE II AT NINE23 APARTMEN	367.00		12/30/22		
		HAP Wilson J 012023									
1067		07/23 AP		01/01/23	0039114	VILLAGE II AT NINE23 APARTMEN	430.00		12/30/22		
		HAP Billman D 012023									
1067		07/23 AP		01/01/23	0039114	VILLAGE II AT NINE23 APARTMEN	429.00		12/30/22		
		HAP Cruise B 012023									
1067		07/23 AP		01/01/23	0039114	VILLAGE II AT NINE23 APARTMEN	444.00		12/30/22		
		HAP Garrigus S 012023									
1067		07/23 AP		01/01/23	0039114	VILLAGE II AT NINE23 APARTMEN	309.00		12/30/22		
		HAP Lane S 012023									
1067		07/23 AP		01/01/23	0039114	VILLAGE II AT NINE23 APARTMEN	649.00		12/30/22		
		HAP Willis C 012023									
1067		07/23 AP		01/01/23	0039114	VILLAGE II AT NINE23 APARTMEN	19.00		12/30/22		
		HAP Hoodjer S 012023									
1067		07/23 AP		01/01/23	0039114	VILLAGE II AT NINE23 APARTMEN	430.00		12/30/22		
		HAP Lam K 012023									
1067		07/23 AP		01/01/23	0039114	VILLAGE II AT NINE23 APARTMEN	357.00		12/30/22		
		HAP OBrien N 012023									
1067		07/23 AP		01/01/23	0039114	VILLAGE II AT NINE23 APARTMEN	265.00		12/30/22		
		HAP O'dell J 012023									
1067		07/23 AP		01/01/23	0039114	VILLAGE II AT NINE23 APARTMEN	600.00		12/30/22		
		HAP BALM D 012023									
1067		07/23 AP		01/01/23	0039114	VILLAGE II AT NINE23 APARTMEN	434.00		12/30/22		
		HAP Humphrey E 012023									
1067		07/23 AP		01/01/23	0039114	VILLAGE II AT NINE23 APARTMEN	197.00		12/30/22		
		HAP Humphrey J 012023									
1067		07/23 AP		01/01/23	0039114	VILLAGE II AT NINE23 APARTMEN	62.00		12/30/22		
		HAP Rogers E 012023									
1067		07/23 AP		01/01/23	0039114	VILLAGE II AT NINE23 APARTMEN	702.00		12/30/22		
		HAP Wilson S 012023									
1067		07/23 AP		01/01/23	0039079	HOUSING AUTHORITY OF JOLIET	1,067.00		12/30/22		
		HAP Wilson Q 012023									
1067		07/23 AP		01/01/23	0039079	HOUSING AUTHORITY OF JOLIET	1,960.00		12/30/22		
		HAP Payne I 012023									
1067		07/23 AP		01/01/23	0039080	HOWARD, BRAD	1,008.00		12/30/22		

PREPARED 01/10/2023, 10:15:33
PROGRAM GM360L
CITY OF CEDAR FALLS

ACCOUNT ACTIVITY LISTING

PAGE 23
ACCOUNTING PERIOD 06/2023

GROUP NBR	PO NBR	ACCTG PER.	CD	DATE	TRANSACTION NUMBER	DESCRIPTION	DEBITS	CREDITS	CURRENT BALANCE	POST DT
FUND 217 SECTION 8 HOUSING FUND										
217-2214-432.89-61 MISCELLANEOUS SERVICES / HOUS.ASSIST PMTS-OCCUPIED continued										
1067				07/23	HAP_Thrower M 012023 AP 01/01/23 0039089	KREMER PROPERTIES LLC	124.00		12/30/22	
1067				07/23	HAP_Mulanax W 012023 AP 01/01/23 0039088	KRAAYENBRINK, RANDY L.	836.00		12/30/22	
1067				07/23	HAP_Ewing J 012023 AP 01/01/23 0039088	KRAAYENBRINK, RANDY L.	532.00		12/30/22	
1067				07/23	HAP_Maltas M 012023 AP 01/01/23 0039101	R & R RENTAL PROPERTIES, LLC	489.00		12/30/22	
1067				07/23	HAP_Stewart J 012023 AP 01/01/23 0039052	BUTLER, MICHAEL	495.00		12/30/22	
1067				07/23	HAP_Cochran C 012023 AP 01/01/23 0039081	HUNTER PROPERTY LLC	768.00		12/30/22	
1067				07/23	HAP_Thompson L 012023 AP 01/01/23 0039077	HAGEDORN, JEREMIAH	796.00		12/30/22	
1067				07/23	HAP_Gottfried L 012023 AP 01/01/23 0039107	SUNRISE PROPERTIES LLC	291.00		12/30/22	
1067				07/23	HAP_Lake L 012023 AP 01/01/23 0039087	KOG PROPERTIES LLC	1,123.00		12/30/22	
1067				07/23	HAP_Atkins T 012023 AP 01/01/23 0039075	GOV, LLC	1,100.00		12/30/22	
1067				07/23	HAP_Guzzle T 012023 AP 01/01/23 0039054	CARL ERICSON	867.00		12/30/22	
1067				07/23	HAP_Burk B 012023 AP 01/01/23 0039054	CARL ERICSON	660.00		12/30/22	
1067				07/23	HAP_Cooper L 012023 AP 01/01/23 0039054	CARL ERICSON	820.00		12/30/22	
1067				07/23	HAP_Leohr K 012023 AP 01/01/23 0039098	PANHWAR, ABDUL	17.00		12/30/22	
1067				07/23	HAP_Mussman C 012023 AP 01/01/23 0039086	KIDWELL, STEVE	599.00		12/30/22	
1067				07/23	HAP_Tomlyanovich C 012023 AP 01/01/23 0039060	CND PROPERTIES LLC	281.00		12/30/22	
1067				07/23	HAP_Gilmore A 012023 AP 01/01/23 0039116	WINGERT, BRIAN	625.00		12/30/22	
1067				07/23	HAP_Holden K 012023 AP 01/01/23 0039106	STEIN INVESTMENTS, LLC	512.00		12/30/22	
1067				07/23	HAP_Gordon A 012023 AP 01/01/23 0039096	OAKVIEW PROPERTIES LLC	1,000.00		12/30/22	
1067				07/23	HAP_Jurries P 012023 AP 01/01/23 0039057	CEDAR VALLEY LIVING LLC	224.00		12/30/22	
1067				07/23	HAP_White L 012023 AP 01/01/23 0039057	CEDAR VALLEY LIVING LLC	306.00		12/30/22	
1067				07/23	HAP_Bachman K 012023 AP 01/01/23 0039110	THIRD AVE PLACE LLC	895.00		12/30/22	
1067				07/23	HAP_Boehmer R 012023 AP 01/01/23 0039085	KELLY PROPERTY INVESTMENTS LL	279.00		12/30/22	
1067				07/23	HAP_Clayton R 012023 AP 01/01/23 0039094	MCKERNAN, PAMELA	324.00		12/30/22	
					HAP_Buchanan J 012023					

PREPARED 01/10/2023, 10:15:33
 PROGRAM GM360L
 CITY OF CEDAR FALLS

ACCOUNT ACTIVITY LISTING

PAGE 24
 ACCOUNTING PERIOD 06/2023

GROUP NBR	PO NBR	ACCTG PER.	CD	DATE	TRANSACTION NUMBER	DESCRIPTION	DEBITS	CREDITS	CURRENT BALANCE	POST DT
FUND 217 SECTION 8 HOUSING FUND										
217-2214-432.89-61 MISCELLANEOUS SERVICES / HOUS.ASSIST PMTS-OCCUPIED						continued				
1067		07/23 AP		01/01/23	0039093	MCH INVESTMENTS LLC	383.00		12/30/22	
		HAP_Barr G 012023								
1067		07/23 AP		01/01/23	0039093	MCH INVESTMENTS LLC	511.00		12/30/22	
		HAP_Langel A 012023								
1067		07/23 AP		01/01/23	0039066	ELMCREST ESTATES, L.C.	422.00		12/30/22	
		HAP_Davis D 012023								
1067		07/23 AP		01/01/23	0039070	G P MANAGEMENT LLC	414.00		12/30/22	
		HAP_Wenzel J 012023								
1067		07/23 AP		01/01/23	0039109	T.J.J.C. L.L.C.	282.00		12/30/22	
		HAP_Dornbrock M 012023								
1067		07/23 AP		01/01/23	0039109	T.J.J.C. L.L.C.	204.00		12/30/22	
		HAP_Hornback K 012023								
1067		07/23 AP		01/01/23	0039109	T.J.J.C. L.L.C.	675.00		12/30/22	
		HAP_Bracelly J 012023								
1067		07/23 AP		01/01/23	0039109	T.J.J.C. L.L.C.	458.00		12/30/22	
		HAP_Fruchtenicht J 012023								
1067		07/23 AP		01/01/23	0039109	T.J.J.C. L.L.C.	327.00		12/30/22	
		HAP_Beck D 012023								
1067		07/23 AP		01/01/23	0039072	GERDES III, BENJAMIN P.	307.00		12/30/22	
		HAP_Allessi S 012023								
1067		07/23 AP		01/01/23	0039072	GERDES III, BENJAMIN P.	1,333.00		12/30/22	
		HAP_BRINER K 012023								
1067		07/23 AP		01/01/23	0039072	GERDES III, BENJAMIN P.	726.00		12/30/22	
		HAP_Orgell A 012023								
1067		07/23 AP		01/01/23	0039072	GERDES III, BENJAMIN P.	884.00		12/30/22	
		HAP_Barnes A 012023								
1067		07/23 AP		01/01/23	0039082	J & A PROPERTIES	1,300.00		12/30/22	
		HAP_Lowe L 012023								
1067		07/23 AP		01/01/23	0039049	BARTELT RENTALS L.C.	994.00		12/30/22	
		HAP_Woods N 012023								
1067		07/23 AP		01/01/23	0039049	BARTELT RENTALS L.C.	572.00		12/30/22	
		HAP_Luck J 012023								
1067		07/23 AP		01/01/23	0039053	C & H HOLDINGS LLC	580.00		12/30/22	
		HAP_Ross S 012023								
1101		07/23 AP		12/01/22	0039121	GLEESON II, JAMES G.	800.00		01/05/23	
		HAP_PRIOR D 122022 REISSUE CK# 38997								
1044		06/23 AP		11/01/22	0038922	GLEESON II, JAMES G.		800.00	12/27/22	
		VOID CHECK LOST HAP_Prior D 112022								
ACCOUNT TOTAL							88,651.00	800.00	87,851.00	
217-2214-432.89-65 MISCELLANEOUS SERVICES / ADMIN FEE DUE OTHERS										
1067		07/23 AP		01/01/23	0039061	COOK CO.HOUSING AUTHORITY	34.16		12/30/22	
		AF_Goldstein K 012023								
1067		07/23 AP		01/01/23	0039079	HOUSING AUTHORITY OF JOLIET	48.79		12/30/22	
		AF_Wilson Q 012023								
1067		07/23 AP		01/01/23	0039079	HOUSING AUTHORITY OF JOLIET	48.79		12/30/22	
		AF_Payne I 012023								

PREPARED 01/10/2023, 10:15:33
PROGRAM GM360L
CITY OF CEDAR FALLS

ACCOUNT ACTIVITY LISTING

PAGE 25
ACCOUNTING PERIOD 06/2023

GROUP NBR	PO NBR	ACCTG PER.	CD	---TRANSACTION--- DATE	NUMBER	DESCRIPTION	DEBITS	CREDITS	CURRENT BALANCE	POST DT
FUND 217 SECTION 8 HOUSING FUND										
217-2214-432.89-65 MISCELLANEOUS SERVICES / ADMIN FEE DUE OTHERS							continued			
ACCOUNT TOTAL							131.74	.00	131.74	
FUND TOTAL							89,118.53	800.00	88,318.53	
FUND 223 COMMUNITY BLOCK GRANT										
223-2224-432.72-99 OPERATING SUPPLIES / POSTAGE										
1125		07/23 AP		01/04/23	0004786	CMRS-POC	3.66		01/09/23	
POC#8031880-REPL.POSTAGE 10/12/22-01/04/23										
ACCOUNT TOTAL							3.66	.00	3.66	
223-2234-432.89-50 MISCELLANEOUS SERVICES / HOUSING REHAB.										
1068		06/23 AP		12/19/22	0004784	TOJO CONSTRUCTION	9,942.00		12/30/22	
CARES ACT REHAB/FINAL PMT 700 W. RIDGEWAY, LOT 435										
PROJECT#: 022351										
ACCOUNT TOTAL							9,942.00	.00	9,942.00	
FUND TOTAL							9,945.66	.00	9,945.66	
FUND 224 TRUST & AGENCY										
FUND 242 STREET REPAIR FUND										
242-1240-431.98-45 CAPITAL PROJECTS / MAIN STREET RECONSTRUCT										
1125		07/23 AP		01/06/23	0398116	BLACK HAWK CO.RECORDER	27.00		01/09/23	
PROJECT#: 3283-PARCEL#186-MAIN ST. RECONST.TEMP.EASE.-CLASBY										
1125		07/23 AP		01/06/23	0398116	BLACK HAWK CO.RECORDER	22.00		01/09/23	
PROJECT#: 3283-PARCEL#295-MAIN ST. WARRANTY DEED-EMAAD, LLC										
1125		07/23 AP		01/06/23	0398116	BLACK HAWK CO.RECORDER	5.00		01/09/23	
PROJECT#: 3283-PARCEL#295-MAIN ST. DEED FEE-EMAAD, LLC										
1125		07/23 AP		01/06/23	0398116	BLACK HAWK CO.RECORDER	22.00		01/09/23	
PROJECT#: 3283-PARCEL#204-MAIN ST. WARRANTY DEED-D&V HOLDING										
1125		07/23 AP		01/06/23	0398116	BLACK HAWK CO.RECORDER	5.00		01/09/23	
PROJECT#: 3283-PARCEL#204-MAIN ST. DEED FEE-D&V HOLDING										
1054		06/23 AP		12/28/22	0398066	ST. PATRICK'S CHURCH	3,715.00		12/28/22	
PROJECT#: 3283-PARCEL#124-MAIN ST. FEE ACQUISTION/TEMP. EASE										
1054		06/23 AP		12/28/22	0398058	BLACK HAWK CO.RECORDER	.80		12/28/22	
PROJECT#: RCD:TRANSFER TAX 3283-PARCEL#124-MAIN ST.										

PREPARED 01/10/2023, 10:15:33
 PROGRAM GM360L
 CITY OF CEDAR FALLS

ACCOUNT ACTIVITY LISTING

PAGE 26
 ACCOUNTING PERIOD 06/2023

GROUP NBR	PO NBR	ACCTG PER.	CD	DATE	TRANSACTION NUMBER	DESCRIPTION	DEBITS	CREDITS	CURRENT BALANCE	POST DT
FUND 242 STREET REPAIR FUND										
242-1240-431.98-45 CAPITAL PROJECTS / MAIN STREET RECONSTRUCT						continued				
					PROJECT#:	023283				
1051		06/23 AP		11/01/22	0398034	D & V HOLDINGS		900.00		12/28/22
						VOID CHECK WRONG AMOUNT				
						10/1-10/31/22 APT. 2 RENT				
					PROJECT#:	023283				
1051		06/23 AP		11/01/22	0398035	D & V HOLDINGS LLC		900.00		12/28/22
						VOID CHECK WRONG AMOUNT				
						6/1-6/30/22 APT. 2 RENT				
					PROJECT#:	023283				
1051		06/23 AP		11/01/22	0398036	D & V HOLDINGS, LLC		900.00		12/28/22
						VOID CHECK WRONG AMOUNT				
						11/1-11/30/22 APT 1 RENT				
					PROJECT#:	023283				
1051		06/23 AP		11/01/22	0398037	D & V HOLDINGS, LLC		900.00		12/28/22
						VOID CHECK WRONG AMOUNT				
						11/1-11/30/22 APT. 2 RENT				
					PROJECT#:	023283				
1051		06/23 AP		11/01/22	0398038	D & V HOLDINGS, LLC		609.68		12/28/22
						VOID CHECK WRONG AMOUNT				
						12/1-12/21/22 APT.1 RENT				
					PROJECT#:	023283				
1051		06/23 AP		11/01/22	0398039	D & V HOLDINGS, LLC		609.68		12/28/22
						VOID CHECK WRONG AMOUNT				
						12/1-12/21/22 APT.2 RENT				
					PROJECT#:	023283				
1051		06/23 AP		11/01/22	0398040	D & V HOLDINGS, LLC		900.00		12/28/22
						VOID CHECK WRONG AMOUNT				
						7/1-7/31/22 APT. 2 RENT				
					PROJECT#:	023283				
1051		06/23 AP		11/01/22	0398041	D & V HOLDINGS, LLC		900.00		12/28/22
						VOID CHECK WRONG AMOUNT				
						8/1-8/31/22 APT. 1 RENT				
					PROJECT#:	023283				
1051		06/23 AP		11/01/22	0398042	D & V HOLDINGS, LLC		900.00		12/28/22
						VOID CHECK WRONG AMOUNT				
						8/1-8/31/22 APT. 2 RENT				
					PROJECT#:	023283				
1051		06/23 AP		11/01/22	0398043	D & V HOLDINGS, LLC		900.00		12/28/22
						VOID CHECK WRONG AMOUNT				
						9/1-9/30/22 APT. 1 RENT				
					PROJECT#:	023283				
1051		06/23 AP		11/01/22	0398044	D & V HOLDINGS, LLC		900.00		12/28/22
						VOID CHECK WRONG AMOUNT				
						9/1-9/30/22 APT. 2 RENT				
					PROJECT#:	023283				
1051		06/23 AP		11/01/22	0398045	D & V HOLDINGS, LLC		900.00		12/28/22
						VOID CHECK WRONG AMOUNT				
						10/1-10/31/22 APT. 1 RENT				
					PROJECT#:	023283				
1045		06/23 AP		10/05/22	0397759	T & R RENTALS, LLC		1,025.00		12/27/22
						VOID CHECK DIFFERENT AMT.				
						3283-PARCEL#41-MAIN ST.				
					PROJECT#:	023283				
1045		06/23 AP		09/29/22	0397674	CASEY'S MARKETING COMPANY		4,175.00		12/27/22
						VOID CHECK DIFFERENT AMT.				
						2383-PARCEL#156-MAIN ST.				
					PROJECT#:	023283				
1045		06/23 AP		09/29/22	0397679	D & J INVESTMENTS, INC.		39,100.00		12/27/22
						VOID CHECK DIFFERENT AMT.				
						3283-PARCEL#11-MAIN ST.				
					PROJECT#:	023283				
1045		06/23 AP		09/29/22	0397680	D & J INVESTMENTS, INC.		86,500.00		12/27/22
						VOID CHECK DIFFERENT AMT.				
						3283-PARCEL#300-MAIN ST.				
					PROJECT#:	023283				

PREPARED 01/10/2023, 10:15:33
 PROGRAM GM360L
 CITY OF CEDAR FALLS

ACCOUNT ACTIVITY LISTING

PAGE 27
 ACCOUNTING PERIOD 06/2023

GROUP NBR	PO NBR	ACCTG PER.	CD	DATE	TRANSACTION NUMBER	DESCRIPTION	DEBITS	CREDITS	CURRENT BALANCE	POST DT	
FUND 242 STREET REPAIR FUND											
242-1240-431.98-45 CAPITAL PROJECTS / MAIN STREET RECONSTRUCT						continued					
1045		06/23 AP		09/29/22	0397681	D & V HOLDINGS, LLC VOID CHECK DIFFERENT AMT. 3283-PARCEL#204-MAIN ST.		264,000.00		12/27/22	
		PROJECT#:			023283						
1045		06/23 AP		09/29/22	0397685	GRACIE MAE PROPERTIES, LC VOID CHECK DIFFERENT AMT. 3283-PARCEL#45-MAIN ST.		7,320.00		12/27/22	
		PROJECT#:			023283						
1045		06/23 AP		09/29/22	0397690	JONATHAN & OLIVA MOSSMAN VOID CHECK DIFFERENT AMT. 3283-PARCEL#206-MAIN ST.		3,620.00		12/27/22	
		PROJECT#:			023283						
1045		06/23 AP		09/29/22	0397694	K3D, LLC VOID CHECK DIFFERENT AMT. 3283-PARCEL#197-MAIN ST.		396,000.00		12/27/22	
		PROJECT#:			023283						
1045		06/23 AP		09/29/22	0397703	TIGERHAWK RENTALS, LLC VOID CHECK DIFFERENT AMT. 3283-PARCEL#205-MAIN ST.		6,365.00		12/27/22	
		PROJECT#:			023283						
1045		06/23 AP		09/29/22	0397704	2C PROPERTIES, LLC VOID CHECK DIFFERENT AMT. 3283-PARCEL#30-MAIN ST.		3,690.00		12/27/22	
		PROJECT#:			023283						
1045		06/23 AP		09/29/22	0397705	2C PROPERTIES, LLC VOID CHECK DIFFERENT AMT. 3283-PARCEL#29-MAIN ST.		2,550.00		12/27/22	
		PROJECT#:			023283						
1045		06/23 AP		09/20/22	0397737	DEV PROPERTIES, LLC VOID CHECK DIFFERENT AMT. 3283-PARCEL#130-MAIN ST.		1,710.00		12/27/22	
		PROJECT#:			023283						
1045		06/23 AP		09/20/22	0397739	DJS PROPERTIES, LLC VOID CHECK DIFFERENT AMT. 3283-PARCEL#39-40-MAIN ST		7,320.00		12/27/22	
		PROJECT#:			023283						
1045		06/23 AP		09/20/22	0397756	ST. PATRICK'S CHURCH VOID CHECK DIFFERENT AMT. 3283-PARCEL#124-MAIN ST.		3,715.00		12/27/22	
		PROJECT#:			023283						
		ACCOUNT TOTAL						3,796.80	837,309.36	833,512.56-	
		FUND TOTAL						3,796.80	837,309.36	833,512.56-	
FUND 254 CABLE TV FUND											
254-1088-431.72-01 OPERATING SUPPLIES / OPERATING SUPPLIES											
1125		07/23 AP		01/04/23	0398117	CMRS-POC POC#8031880-REPL.POSTAGE 10/12/22-01/04/23	26.52			01/09/23	
		ACCOUNT TOTAL						26.52	.00	26.52	
254-1088-431.89-18 MISCELLANEOUS SERVICES / COMMUNITY PROGRAMMING											
1125		07/23 AP		01/06/23	0398124	SIMPSON, MARK CF GIRLS BB V. LINN-MAR ANNOUNCER	120.00			01/09/23	
		PROJECT#:			759						

PREPARED 01/10/2023, 10:15:33
 PROGRAM GM360L
 CITY OF CEDAR FALLS

ACCOUNT ACTIVITY LISTING

PAGE 28
 ACCOUNTING PERIOD 06/2023

GROUP NBR	PO NBR	ACCTG PER.	CD	DATE	-----TRANSACTION----- NUMBER	DESCRIPTION	DEBITS	CREDITS	CURRENT BALANCE	POST DT
FUND 254 CABLE TV FUND										
254-1088-431.89-18 MISCELLANEOUS SERVICES / COMMUNITY PROGRAMMING						continued				
1125		07/23 AP		01/06/23	0398122	LONGNECKER, JEREMIAH ANNOUNCER	100.00		01/09/23	
		PROJECT#:			759	CF GIRLS BB V. LINN-MAR				
1125		07/23 AP		01/06/23	0398118	DEWITT, JASON CAMERA OPERATOR	100.00		01/09/23	
		PROJECT#:			759	CF GIRLS BB V. LINN-MAR				
1125		07/23 AP		01/06/23	0398125	SURMA, JOSEPH EDWARD CAMERA OPERATOR	100.00		01/09/23	
		PROJECT#:			759	CF GIRLS BB V. LINN-MAR				
1125		07/23 AP		01/06/23	0398115	BENSON, ERIC CAMERA OPERATOR	100.00		01/09/23	
		PROJECT#:			759	CF GIRLS BB V. LINN-MAR				
1125		07/23 AP		01/05/23	0398118	DEWITT, JASON CAMERA OPERATOR	150.00		01/09/23	
		PROJECT#:			756	UNI WRESTLING V. WYOMING				
1125		07/23 AP		01/05/23	0398125	SURMA, JOSEPH EDWARD CAMERA OPERATOR	150.00		01/09/23	
		PROJECT#:			756	UNI WRESTLING V. WYOMING				
1068		06/23 AP		12/28/22	0398072	DEWITT, JASON CAMERA OPERATOR	170.00		12/30/22	
		PROJECT#:			756	UNI MENS BB V.MISSOURI ST				
1068		06/23 AP		12/28/22	0398076	SURMA, JOSEPH EDWARD CAMERA OPERATOR	170.00		12/30/22	
		PROJECT#:			756	UNI MENS BB V.MISSOURI ST				
1068		06/23 AP		12/28/22	0398075	STOW, CHRISTIAN CAMERA OPERATOR	170.00		12/30/22	
		PROJECT#:			756	UNI MENS BB V.MISSOURI ST				
1068		06/23 AP		12/28/22	0398073	KRESS, AGNES M CAMERA OPERATOR	100.00		12/30/22	
		PROJECT#:			756	UNI MENS BB V.MISSOURI ST				
1054		06/23 AP		12/21/22	0398070	WATERS, ROBERT EDWARD PHONE PRODUCER	150.00		12/28/22	
		PROJECT#:			756	UNI MENS BB V.BONAVENTURE				
1054		06/23 AP		12/21/22	0398062	DEWITT, JASON CAMERA OPERATOR	170.00		12/28/22	
		PROJECT#:			756	UNI MENS BB V.BONAVENTURE				
1054		06/23 AP		12/21/22	0398068	SURMA, JOSEPH EDWARD CAMERA OPERATOR	170.00		12/28/22	
		PROJECT#:			756	UNI MENS BB V.BONAVENTURE				
1054		06/23 AP		12/21/22	0398061	CORNWELL, JOSEPH GLEN CAMERA OPERATOR	120.00		12/28/22	
		PROJECT#:			756	UNI MENS BB V.BONAVENTURE				
1054		06/23 AP		12/21/22	0398063	KRESS, AGNES M CAMERA OPERATOR	120.00		12/28/22	
		PROJECT#:			756	UNI MENS BB V.BONAVENTURE				
1054		06/23 AP		12/20/22	0398065	SIMPSON, MARK ANNOUNCER	120.00		12/28/22	
		PROJECT#:			759	CF GIRLS BB V.WESTERN DBQ				
1054		06/23 AP		12/20/22	0398064	LONGNECKER, JEREMIAH	100.00		12/28/22	

PREPARED 01/10/2023, 10:15:33
 PROGRAM GM360L
 CITY OF CEDAR FALLS

ACCOUNT ACTIVITY LISTING

PAGE 29
 ACCOUNTING PERIOD 06/2023

GROUP NBR	PO NBR	ACCTG PER.	CD	DATE	TRANSACTION NUMBER	DESCRIPTION	DEBITS	CREDITS	CURRENT BALANCE	POST DT
FUND 254 CABLE TV FUND										
254-1088-431.89-18 MISCELLANEOUS SERVICES / COMMUNITY PROGRAMMING						continued				
CF GIRLS BB V.WESTERN DBQ						ANNOUNCER				
PROJECT#:	759									
1054	06/23	AP	12/20/22	0398062	DEWITT, JASON	100.00			12/28/22	
CF GIRLS BB V.WESTERN DBQ						CAMERA OPERATOR				
PROJECT#:	759									
1054	06/23	AP	12/20/22	0398068	SURMA, JOSEPH EDWARD	100.00			12/28/22	
CF GIRLS BB V.WESTERN DBQ						CAMERA OPERATOR				
PROJECT#:	759									
1054	06/23	AP	12/20/22	0398067	STOW, CHRISTIAN	100.00			12/28/22	
CF GIRLS BB V.WESTERN DBQ						CAMERA OPERATOR				
PROJECT#:	759									
1054	06/23	AP	12/20/22	0398069	WALTERS, CLAYTON	100.00			12/28/22	
CF GIRLS BB V.WESTERN DBQ						CAMERA OPERATOR				
PROJECT#:	759									
1054	06/23	AP	12/20/22	0398063	KRESS, AGNES M	100.00			12/28/22	
CF GIRLS BB V.WESTERN DBQ						CAMERA OPERATOR				
PROJECT#:	759									
ACCOUNT TOTAL						2,880.00	0.00		2,880.00	
FUND TOTAL						2,906.52	0.00		2,906.52	
FUND 258 PARKING FUND										
258-5531-435.72-01 OPERATING SUPPLIES / OPERATING SUPPLIES										
1015	06/23	AP	12/02/22	0006616	PROFESSIONAL SOLUTIONS	233.89			01/03/23	
NOVEMBER CREDIT CARD FEES										
1015	06/23	AP	12/02/22	0006601	PROFESSIONAL SOLUTIONS	64.24			01/03/23	
NOVEMBER CREDIT CARD FEES										
1015	06/23	AP	12/02/22	0006602	PROFESSIONAL SOLUTIONS	267.66			01/03/23	
NOVEMBER CREDIT CARD FEES										
1015	06/23	AP	12/02/22	0006604	PROFESSIONAL SOLUTIONS	60.52			01/03/23	
NOVEMBER CREDIT CARD FEES										
ACCOUNT TOTAL						626.31	0.00		626.31	
258-5531-435.72-99 OPERATING SUPPLIES / POSTAGE										
1125	07/23	AP	01/04/23	0398117	CMRS-POC	7.41			01/09/23	
POC#8031880-REPL.POSTAGE						10/12/22-01/04/23				
ACCOUNT TOTAL						7.41	0.00		7.41	
FUND TOTAL						633.72	0.00		633.72	

PREPARED 01/10/2023, 10:15:33
 PROGRAM GM360L
 CITY OF CEDAR FALLS

ACCOUNT ACTIVITY LISTING

PAGE 30
 ACCOUNTING PERIOD 06/2023

GROUP NBR	PO NBR	ACCTG PER.	CD	DATE	TRANSACTION NUMBER	DESCRIPTION	DEBITS	CREDITS	CURRENT BALANCE	POST DT
FUND 261 TOURISM & VISITORS										
261-2291-423.72-99						OPERATING SUPPLIES / POSTAGE				
1125		07/23 AP		01/04/23	0398117	CMRS-POC	217.83			01/09/23
						POC#8031880-REPL.POSTAGE				10/12/22-01/04/23
						ACCOUNT TOTAL	217.83	.00	217.83	
261-2291-423.73-57 OTHER SUPPLIES / GIFT SHOP										
1015		06/23 AP		12/02/22	0006608	PROFESSIONAL SOLUTIONS	42.71			01/03/23
						NOVEMBER CREDIT CARD FEES				
						ACCOUNT TOTAL	42.71	.00	42.71	
						FUND TOTAL	260.54	.00	260.54	
FUND 262 SENIOR SERVICES & COMM CT										
262-1092-423.72-99						OPERATING SUPPLIES / POSTAGE				
1125		07/23 AP		01/04/23	0398117	CMRS-POC	3.99			01/09/23
						POC#8031880-REPL.POSTAGE				10/12/22-01/04/23
						ACCOUNT TOTAL	3.99	.00	3.99	
262-1092-423.85-01 UTILITIES / UTILITIES										
880		07/23 AP		12/05/22	0398095	CEDAR FALLS UTILITIES	786.68			12/29/22
						COMM. CENTER UTILITIES				
						ACCOUNT TOTAL	786.68	.00	786.68	
						FUND TOTAL	790.67	.00	790.67	
FUND 291 POLICE FORFEITURE FUND										
FUND 292 POLICE RETIREMENT FUND										
292-5521-415.54-01						WORKERS COMP / POLICE WORKERS COMP				
1015		06/23 AP		12/13/22	0006584	EMC RISK SERVICES, LLC	450.00			01/03/23
						WORKER COMP-POLICE CLAIM				
						ACCOUNT TOTAL	450.00	.00	450.00	
						FUND TOTAL	450.00	.00	450.00	

PREPARED 01/10/2023, 10:15:33
PROGRAM GM360L
CITY OF CEDAR FALLS

ACCOUNT ACTIVITY LISTING

PAGE 31
ACCOUNTING PERIOD 06/2023

GROUP	PO	ACCTG	---TRANSACTION---		DESCRIPTION	DEBITS	CREDITS	CURRENT	POST DT
NBR	NBR	PER.	CD	DATE	NUMBER			BALANCE	
FUND 293 FIRE RETIREMENT FUND									
293-4511-414.54-02					WORKERS COMP / FIRE WORKERS COMP				
1015		06/23	AP	12/13/22	0006584 EMC RISK SERVICES, LLC	4,803.23			01/03/23
					WORKER COMP-FIRE ADMIN				
					ACCOUNT TOTAL	4,803.23	.00	4,803.23	
					FUND TOTAL	4,803.23	.00	4,803.23	
FUND 294 LIBRARY RESERVE									
FUND 295 SOFTBALL PLAYER CAPITAL									
FUND 296 GOLF CAPITAL									
FUND 297 REC FACILITIES CAPITAL									
FUND 298 HEARST CAPITAL									
FUND 311 DEBT SERVICE FUND									
FUND 402 WASHINGTON PARK FUND									
FUND 404 FEMA									
404-1220-431.92-37					STRUCTURE IMPROV & BLDGS / BUYOUT DEMOLITIONS				
1125		07/23	AP	01/04/23	0398117 CMRS-POC	37.41			01/09/23
					POC#8031880-REPL.POSTAGE 10/12/22-01/04/23				
					ACCOUNT TOTAL	37.41	.00	37.41	
					FUND TOTAL	37.41	.00	37.41	
FUND 405 FLOOD RESERVE FUND									
FUND 407 VISION IOWA PROJECT									
FUND 408 STREET IMPROVEMENT FUND									
FUND 410 CORONAVIRUS LOCAL RELIEF									
FUND 430 2004 TIF BOND									
FUND 431 2014 BOND									
FUND 432 2003 BOND									
FUND 433 2001 TIF									
FUND 434 2000 BOND									
FUND 435 1999 TIF									
FUND 436 2012 BOND									
FUND 437 2018 BOND									
FUND 438 2020 BOND FUND									
FUND 439 2022 BOND FUND									
FUND 443 CAPITAL PROJECTS									
FUND 472 PARKADE RENOVATION									
FUND 473 SIDEWALK ASSESSMENT									

PREPARED 01/10/2023, 10:15:33
 PROGRAM GM360L
 CITY OF CEDAR FALLS

ACCOUNT ACTIVITY LISTING

PAGE 33
 ACCOUNTING PERIOD 06/2023

GROUP	PO	ACCTG	---	TRANSACTION---					
NBR	NBR	PER.	CD	DATE	NUMBER	DESCRIPTION	DEBITS	CREDITS	CURRENT BALANCE POST DT
FUND 551 REFUSE FUND									
551-6685-436.87-02 RENTALS / MATERIAL DISPOSAL/HANDLIN						continued			
ACCOUNT TOTAL							22,576.32	.00	22,576.32
551-6685-436.89-04 MISCELLANEOUS SERVICES / SALES TAX									
1015		06/23 AP		12/08/22	0006593	IOWA DEPT.OF REVENUE	170.78		01/03/23
						MONTHLY SALES TAX			
ACCOUNT TOTAL							170.78	.00	170.78
FUND TOTAL							23,766.47	.00	23,766.47
FUND 552 SEWER RENTAL FUND									
552-6655-436.72-99 OPERATING SUPPLIES / POSTAGE									
1125		07/23 AP		01/04/23	0398117	CMRS-POC	19.95		01/09/23
						POC#8031880-REPL.POSTAGE			
						10/12/22-01/04/23			
ACCOUNT TOTAL							19.95	.00	19.95
552-6655-436.85-01 UTILITIES / UTILITIES									
1068		06/23 AP		12/20/22	0398071	CEDAR FALLS UTILITIES	960.52		12/30/22
						UTILITIES THRU 12/20/22			
ACCOUNT TOTAL							960.52	.00	960.52
552-6665-436.72-99 OPERATING SUPPLIES / POSTAGE									
1125		07/23 AP		01/04/23	0398117	CMRS-POC	27.27		01/09/23
						POC#8031880-REPL.POSTAGE			
						10/12/22-01/04/23			
ACCOUNT TOTAL							27.27	.00	27.27
552-6665-436.86-33 REPAIR & MAINTENANCE / SLUDGE REMOVAL									
1054		06/23 AP		12/15/22	0398056	BLACK HAWK CO.LANDFILL	62.11		12/28/22
						LANDFILL SRV:12/1-12/15			
						12/1/22-12/15/22			
ACCOUNT TOTAL							62.11	.00	62.11
552-6665-436.89-04 MISCELLANEOUS SERVICES / SALES TAX									
1015		06/23 AP		12/08/22	0006593	IOWA DEPT.OF REVENUE	8,897.45		01/03/23
						MONTHLY SALES TAX			
						COMMERCIAL SEWER			
ACCOUNT TOTAL							8,897.45	.00	8,897.45

PREPARED 01/10/2023, 10:15:33
 PROGRAM GM360L
 CITY OF CEDAR FALLS

ACCOUNT ACTIVITY LISTING

PAGE 34
 ACCOUNTING PERIOD 06/2023

GROUP	PO	ACCTG	----TRANSACTION----		DESCRIPTION	DEBITS	CREDITS	CURRENT
NBR	NBR	PER.	CD	DATE	NUMBER			BALANCE
								POST DT
FUND 552 SEWER RENTAL FUND								
					FUND TOTAL	9,967.30	.00	9,967.30
FUND 553 2004 SEWER BOND								
FUND 555 STORM WATER UTILITY								
					555-6630-432.72-01 OPERATING SUPPLIES / OPERATING SUPPLIES			
1125		07/23 AP		01/04/23	0398117 CMRS-POC	3.42		01/09/23
					POC#8031880-REPL.POSTAGE 10/12/22-01/04/23			
					ACCOUNT TOTAL	3.42	.00	3.42
					FUND TOTAL	3.42	.00	3.42
FUND 570 SEWER ASSESSMENT								
FUND 606 DATA PROCESSING FUND								
					606-1078-441.64-02 INSURANCE / HEALTH INS. REIMBURSEMENT			
1015		06/23 AP		12/13/22	0006598 ISOLVED BENEFIT SERVICES, INC	100.00		01/03/23
					HEALTH INS. REIMBURSEMENT			
					ACCOUNT TOTAL	100.00	.00	100.00
					606-1078-441.72-01 OPERATING SUPPLIES / OPERATING SUPPLIES			
1125		07/23 AP		01/04/23	0398117 CMRS-POC	80.56		01/09/23
					POC#8031880-REPL.POSTAGE 10/12/22-01/04/23			
					ACCOUNT TOTAL	80.56	.00	80.56
					606-1078-441.82-10 COMMUNICATION / TELEPHONE HOLDING ACCOUNT			
1082		07/23 AP		12/19/22	0398083 VERIZON WIRELESS	1,600.96		01/03/23
					WIRELESS SRV:12/20-01/19 12/20/22-01/19/23			
1082		07/23 AP		12/06/22	0398082 U.S. CELLULAR	2,696.39		01/03/23
					WIRELESS SRV:12/06-01/05 12/06/22-01/05/23			
					ACCOUNT TOTAL	4,297.35	.00	4,297.35
					FUND TOTAL	4,477.91	.00	4,477.91
FUND 680 HEALTH INSURANCE FUND								
					680-1902-457.51-01 INSURANCE / HEALTH INSURANCE			
1015		06/23 AP		12/30/22	0006626 WELLMARK IOWA	44,185.79		01/03/23
					HEALTH CLAIMS PROCESSING			
1015		06/23 AP		12/27/22	0006588 EXPRESS SCRIPTS, INC.	45,465.22		01/03/23
					RX CLAIMS PROCESSING			
1015		06/23 AP		12/27/22	0006627 WEX HEALTH, INC.	120.75		01/03/23

PREPARED 01/10/2023, 10:15:33
 PROGRAM GM360L
 CITY OF CEDAR FALLS

ACCOUNT ACTIVITY LISTING

PAGE 36
 ACCOUNTING PERIOD 06/2023

GROUP	PO	ACCTG	----	TRANSACTION	----	DESCRIPTION	DEBITS	CREDITS	CURRENT	POST	DT
NBR	NBR	PER.	CD	DATE	NUMBER				BALANCE		
FUND 682 HEALTH INSURANCE - FIRE											
FUND 685 VEHICLE MAINTENANCE FUND											
FUND 686 PAYROLL FUND											
686-0000-222.01-00						PAYROLL LIABILITY / FEDERAL TAXES					
1015		06/23	AP	12/19/22	0006618	UNITED STATES TREASURY	66,478.44			01/03/23	
						FEDERAL WITHHOLDING TAX					
1015		06/23	AP	12/05/22	0006617	UNITED STATES TREASURY	68,491.23			01/03/23	
						FEDERAL WITHHOLDING TAX					
						ACCOUNT TOTAL	134,969.67	.00		134,969.67	
686-0000-222.02-00 PAYROLL LIABILITY / STATE WITHHOLDING											
1015		06/23	AP	12/19/22	0006595	IOWA DEPT.OF REVENUE	28,776.12			01/03/23	
						STATE WITHHOLDING TAX					
1015		06/23	AP	12/05/22	0006594	IOWA DEPT.OF REVENUE	29,552.91			01/03/23	
						STATE WITHHOLDING TAX					
						ACCOUNT TOTAL	58,329.03	.00		58,329.03	
686-0000-222.03-00 PAYROLL LIABILITY / FICA											
1015		06/23	AP	12/19/22	0006618	UNITED STATES TREASURY	72,946.18			01/03/23	
						SS & MQGE/MEDICARE TAX					
1015		06/23	AP	12/05/22	0006617	UNITED STATES TREASURY	74,000.32			01/03/23	
						SS & MQGE/MEDICARE TAX					
						ACCOUNT TOTAL	146,946.50	.00		146,946.50	
686-0000-222.05-00 PAYROLL LIABILITY / OTHER DEDUCTIONS PAYABLE											
1015		06/23	AP	12/30/22	0006600	ISOLVED BENEFIT SERVICES, INC	6,535.96			01/03/23	
						CAFETERIA PLAN					
1054		06/23	AP	12/28/22	0398060	CEDAR VALLEY UNITED WAY	322.00			12/28/22	
						4TH QTR.2022 CONTRIBUTION					
1054		06/23	AP	12/28/22	0398059	CEDAR FALLS COMMUNITY FOUNDAT	35.00			12/28/22	
						4TH QTR.2022 CONTRIBUTION					
1015		06/23	AP	12/28/22	0006620	VOYA FINANCIAL	8,605.45			01/03/23	
						EMPLOYEE 457 CONTRIBUTION					
1015		06/23	AP	12/19/22	0006582	COLLECTION SERVICES CENTER	611.85			01/03/23	
						CHILD SUPPORT PAYMENTS					
1015		06/23	AP	12/19/22	0006599	ISOLVED BENEFIT SERVICES, INC	6,583.82			01/03/23	
						CAFETERIA PLAN					
1015		06/23	AP	12/14/22	0006619	VOYA FINANCIAL	8,605.45			01/03/23	
						EMPLOYEE 457 CONTRIBUTION					
1015		06/23	AP	12/05/22	0006581	COLLECTION SERVICES CENTER	611.85			01/03/23	
						CHILD SUPPORT PAYMENTS					
1015		06/23	AP	12/02/22	0006596	ISOLVED BENEFIT SERVICES, INC	6,583.82			01/03/23	
						CAFETERIA PLAN					
						ACCOUNT TOTAL	38,495.20	.00		38,495.20	

PREPARED 01/10/2023, 10:15:33
 PROGRAM GM360L
 CITY OF CEDAR FALLS

ACCOUNT ACTIVITY LISTING

PAGE 37
 ACCOUNTING PERIOD 06/2023

GROUP	PO	ACCTG	---TRANSACTION---		DESCRIPTION	DEBITS	CREDITS	CURRENT
NBR	NBR	PER.	CD	DATE	NUMBER			BALANCE
								POST DT
FUND 686 PAYROLL FUND								
					FUND TOTAL	378,740.40	.00	378,740.40
FUND 687 WORKERS COMPENSATION FUND								
687-1902-457.51-02 INSURANCE / WORKERS COMP INSURANCE								
1015		06/23	AP	12/13/22	0006584	EMC RISK SERVICES, LLC	450.14	01/03/23
						WORKER COMP ADMIN FEES		
1015		06/23	AP	12/13/22	0006584	EMC RISK SERVICES, LLC	450.00	01/03/23
						WORKER COMP CLAIM		
					ACCOUNT TOTAL	900.14	.00	900.14
					FUND TOTAL	900.14	.00	900.14
FUND 688 LTD INSURANCE FUND								
FUND 689 LIABILITY INSURANCE FUND								
689-1902-457.51-05 INSURANCE / LIABILITY INSURANCE								
1015		06/23	AP	12/13/22	0006584	EMC RISK SERVICES, LLC	1,225.00	01/03/23
						LIABILITY ADMIN FEES		
1015		06/23	AP	12/13/22	0006584	EMC RISK SERVICES, LLC	2,700.00	01/03/23
						LIABILITY CLAIM		
					ACCOUNT TOTAL	3,925.00	.00	3,925.00
					FUND TOTAL	3,925.00	.00	3,925.00
FUND 724 TRUST & AGENCY								
FUND 727 GREENWOOD CEMETERY P-CARE								
FUND 728 FAIRVIEW CEMETERY P-CARE								
FUND 729 HILLSIDE CEMETERY P-CARE								
FUND 790 FLOOD LEVY								
					GRAND TOTAL	1,073,858.07	838,109.36	235,748.71

COUNCIL INVOICES FOR 01/17/2023 MEETING

Item 24.

PREPARED 01/10/2023, 11:21:08
 PROGRAM GM360L
 CITY OF CEDAR FALLS

ACCOUNT ACTIVITY LISTING

PAGE 1
 ACCOUNTING PERIOD 06/2023

GROUP NBR	PO NBR	ACCTG PER.	----TRANSACTION----	CD	DATE	NUMBER	DESCRIPTION	DEBITS	CREDITS	CURRENT BALANCE	POST DT
FUND 101 GENERAL FUND											
101-1008-441.71-01 OFFICE SUPPLIES / OFFICE SUPPLIES											
1042		07/23 AP	12/29/22		0000000		OFFICE EXPRESS OFFICE PRODUCT	.18		01/10/23	
							MASKING TAPE				
1042		07/23 AP	12/28/22		0000000		OFFICE EXPRESS OFFICE PRODUCT	.58		01/10/23	
							TAPE, PUTTY				
1085		07/23 AP	12/28/22		0000000		OFFICE EXPRESS OFFICE PRODUCT	37.99		01/10/23	
							COPY PAPER				
1042		07/23 AP	12/20/22		0000000		OFFICE EXPRESS OFFICE PRODUCT	.72		01/10/23	
							ENVELOPES, GLUE STICKS				
1042		07/23 AP	12/19/22		0000000		OFFICE EXPRESS OFFICE PRODUCT	.10		01/10/23	
							PENS				
1085		07/23 AP	12/01/22		0000000		STOREY KENWORTHY	27.60		01/10/23	
							#10 REGULAR ENVELOPES				
							ACCOUNT TOTAL	67.17	.00	67.17	
101-1008-441.87-01 RENTALS / RENTALS											
1039		07/23 AP	12/14/22		0000000		QUADIENT, INC.	162.00		01/10/23	
							POSTAGE METER RENTAL				
							ACCOUNT TOTAL	162.00	.00	162.00	
101-1026-441.71-01 OFFICE SUPPLIES / OFFICE SUPPLIES											
1085		07/23 AP	12/28/22		0000000		OFFICE EXPRESS OFFICE PRODUCT	7.60		01/10/23	
							COPY PAPER				
							ACCOUNT TOTAL	7.60	.00	7.60	
101-1026-441.83-06 TRANSPORTATION&EDUCATION / EDUCATION											
1113		07/23 AP	12/16/22		0142132		US BANK	167.00		01/06/23	
							IOWA SOCIETY OF CPA				
							TRNG:CONTINUING EDUCATION				
1113		07/23 AP	12/12/22		0142132		US BANK	159.00		01/06/23	
							IOWA SOCIETY OF CPA				
							TRNG:GOV&NP FRAUDS & CTSL				
1113		07/23 AP	12/02/22		0142132		US BANK	129.00		01/06/23	
							IOWA SOCIETY OF CPA				
							TRNG:GOV AUDITING UPDATE				
							ACCOUNT TOTAL	455.00	.00	455.00	
101-1028-441.71-01 OFFICE SUPPLIES / OFFICE SUPPLIES											
1085		07/23 AP	12/28/22		0000000		OFFICE EXPRESS OFFICE PRODUCT	45.58		01/10/23	
							COPY PAPER				
1085		07/23 AP	12/01/22		0000000		STOREY KENWORTHY	2.30		01/10/23	
							#10 REGULAR ENVELOPES				
1085		07/23 AP	12/01/22		0000000		STOREY KENWORTHY	27.60		01/10/23	
							#10 REGULAR ENVELOPES				
							ACCOUNT TOTAL	75.48	.00	75.48	

PREPARED 01/10/2023, 11:21:08
 PROGRAM GM360L
 CITY OF CEDAR FALLS

ACCOUNT ACTIVITY LISTING

PAGE 2
 ACCOUNTING PERIOD 06/2023

GROUP NBR	PO NBR	ACCTG PER.	CD	DATE	TRANSACTION NUMBER	DESCRIPTION	DEBITS	CREDITS	CURRENT BALANCE	POST DT
FUND 101 GENERAL FUND										
101-1028-441.83-06						TRANSPORTATION&EDUCATION / EDUCATION				
1113		07/23 AP		12/07/22	0142132	US BANK	135.00			01/06/23
						GOVERNMENT FINANCE OFFIC				
						REG:GAAP UPDATE-KOCKLER				
						ACCOUNT TOTAL	135.00	0.00	135.00	
101-1038-441.71-01 OFFICE SUPPLIES / OFFICE SUPPLIES										
1085		07/23 AP		12/28/22	0000000	OFFICE EXPRESS OFFICE PRODUCT	30.39			01/10/23
						COPY PAPER				
1085		07/23 AP		12/01/22	0000000	STOREY KENWORTHY	34.50			01/10/23
						#10 REGULAR ENVELOPES				
						ACCOUNT TOTAL	64.89	0.00	64.89	
101-1038-441.81-09 PROFESSIONAL SERVICES / HUMAN RIGHTS COMMISSION										
1085		07/23 AP		12/28/22	0000000	OFFICE EXPRESS OFFICE PRODUCT	3.04			01/10/23
						COPY PAPER				
1085		07/23 AP		12/28/22	0000000	SOCIAL ACTION, INC.	300.00			01/10/23
						MLK BANQUET TICKETS (6)				
1085		07/23 AP		12/01/22	0000000	STOREY KENWORTHY	2.30			01/10/23
						#10 REGULAR ENVELOPES				
						ACCOUNT TOTAL	305.34	0.00	305.34	
101-1038-441.81-49 PROFESSIONAL SERVICES / BACKGROUND CHECK										
1113		07/23 AP		12/07/22	0142132	US BANK	126.90			01/06/23
						ONE SOURCE THE BACKGROUND				
						BACKGROUND CHECKS				
						ACCOUNT TOTAL	126.90	0.00	126.90	
101-1038-441.81-52 PROFESSIONAL SERVICES / DRUG TESTING										
1113		07/23 AP		12/16/22	0142132	US BANK	62.50			01/06/23
						FMCSA D&A CLEARINGHOUSE				
						DRUG & ALCOHOL QUERIES				
						ACCOUNT TOTAL	62.50	0.00	62.50	
101-1038-441.81-53 PROFESSIONAL SERVICES / JOB NOTICES										
1085		07/23 AP		01/06/23	0000000	CEDAR VALLEY SAVER, INC.	75.00			01/10/23
						JOB AD: PT OFFICE ASST				
						1/5/23 DISPLAY/WEB AD				
1085		07/23 AP		12/25/22	0000000	COURIER COMMUNICATIONS-ADVERT	29.40			01/10/23
						COURIER				
1085		07/23 AP		12/25/22	0000000	COURIER COMMUNICATIONS-ADVERT	450.00			01/10/23
						MONTHLY DIGITAL IMPRESSNS				
						ONLINE				
1085		07/23 AP		12/25/22	0000000	COURIER COMMUNICATIONS-ADVERT	29.40			01/10/23
						JOB AD:WW TRMT. OPERATOR				
						COURIER				

PREPARED 01/10/2023, 11:21:08
 PROGRAM GM360L
 CITY OF CEDAR FALLS

ACCOUNT ACTIVITY LISTING

PAGE 3
 ACCOUNTING PERIOD 06/2023

GROUP NBR	PO NBR	ACCTG PER.	CD	DATE	TRANSACTION NUMBER	DESCRIPTION	DEBITS	CREDITS	CURRENT BALANCE	POST DT
FUND 101 GENERAL FUND										
101-1038-441.81-53						PROFESSIONAL SERVICES / JOB NOTICES				continued
1085			AP	12/25/22	0000000	COURIER COMMUNICATIONS-ADVERT COURIER	29.40			01/10/23
						JOB AD:PT MAINT. WORKER				
1085			AP	12/25/22	0000000	COURIER COMMUNICATIONS-ADVERT COURIER	58.40			01/10/23
						JOB AD:PT OFFICE ASST.				
1039			AP	12/23/22	0000000	CEDAR VALLEY SAVER, INC.	75.00			01/10/23
						JOB AD:WATER TREATMENT				
1039			AP	12/23/22	0000000	CEDAR VALLEY SAVER, INC.	75.00			01/10/23
						JOB AD:SEASONAL LABORERS				
1039			AP	12/23/22	0000000	CEDAR VALLEY SAVER, INC.	75.00			01/10/23
						JOB AD:PT MAINT. WORKER				
1085			AP	12/21/22	0000000	COURIER COMMUNICATIONS-ADVERT PULSE	29.40			01/10/23
						JOB AD:PKPW SEASONAL WRKR				
1085			AP	12/21/22	0000000	COURIER COMMUNICATIONS-ADVERT PULSE	29.40			01/10/23
						JOB AD:WW TRMT. OPERATOR				
1085			AP	12/21/22	0000000	COURIER COMMUNICATIONS-ADVERT PULSE	29.40			01/10/23
						JOB AD:PT MAINT. WORKER				
1085			AP	12/18/22	0000000	COURIER COMMUNICATIONS-ADVERT COURIER	29.40			01/10/23
						JOB AD:PKPW SEASONAL WRKR				
1085			AP	12/18/22	0000000	COURIER COMMUNICATIONS-ADVERT COURIER	29.40			01/10/23
						JOB AD:PT MAINT. WORKER				
1085			AP	12/15/22	0000000	COURIER COMMUNICATIONS-ADVERT ONLINE	39.00			01/10/23
						JOB AD:WW TRMT. OPERATOR				
1085			AP	12/14/22	0000000	COURIER COMMUNICATIONS-ADVERT PULSE	29.40			01/10/23
						JOB AD:PKPW SEASONAL WRKR				
1085			AP	12/14/22	0000000	COURIER COMMUNICATIONS-ADVERT PULSE	29.40			01/10/23
						JOB AD:WW TRMT. OPERATOR				
1085			AP	12/14/22	0000000	COURIER COMMUNICATIONS-ADVERT PULSE	29.40			01/10/23
						JOB AD:PT MAINT. WORKER				
1085			AP	12/11/22	0000000	COURIER COMMUNICATIONS-ADVERT AMP DIGITAL	950.00			01/10/23
						MOBILE LOCATION TARGETING				
1085			AP	12/11/22	0000000	COURIER COMMUNICATIONS-ADVERT COURIER	29.40			01/10/23
						JOB AD:PKPW SEASONAL WRKR				
1085			AP	12/11/22	0000000	COURIER COMMUNICATIONS-ADVERT COURIER	58.40			01/10/23
						JOB AD:WW TRMT. OPERATOR				
1085			AP	12/11/22	0000000	COURIER COMMUNICATIONS-ADVERT COURIER	58.40			01/10/23
						JOB AD:PT MAINT. WORKER				
1085			AP	12/07/22	0000000	COURIER COMMUNICATIONS-ADVERT PULSE	29.40			01/10/23
						JOB AD:PKPW SEASONAL WRKR				
1113			AP	12/05/22	0142132	US BANK	119.95			01/06/23
						LINKEDIN 7703516106				
1085			AP	12/04/22	0000000	COURIER COMMUNICATIONS-ADVERT AMP DIGITAL	500.00			01/10/23
						PPC CAMPAIGN				
1085			AP	12/04/22	0000000	COURIER COMMUNICATIONS-ADVERT COURIER	58.40			01/10/23
						JOB AD:PKPW SEASONAL WRKR				
1113			AP	12/02/22	0142132	US BANK	48.00			01/06/23
						ONLINE JOB ADS INDEED				
1039			AP	11/30/22	0000000	REGISTER MEDIA	888.65			01/10/23

PREPARED 01/10/2023, 11:21:08
 PROGRAM GM360L
 CITY OF CEDAR FALLS

ACCOUNT ACTIVITY LISTING

PAGE 4
 ACCOUNTING PERIOD 06/2023

GROUP NBR	PO NBR	ACCTG PER.	CD	-----TRANSACTION----- DATE	NUMBER	DESCRIPTION	DEBITS	CREDITS	CURRENT BALANCE	POST DT
FUND 101 GENERAL FUND										
101-1038-441.81-53						PROFESSIONAL SERVICES / JOB NOTICES				continued
						JOB AD:WASTE WATER TECH				11/1-11/27/22
1113				07/23 AP	11/25/22 0142132	US BANK	399.00			01/06/23
1113				07/23 AP	11/25/22 0142132	US BANK	845.00			01/06/23
						ASSOCIATIO* NSPE JOB B				NSPE JOB BOARD:PRINC.ENGR
						ACCOUNT TOTAL	5,184.80	.00		5,184.80
101-1038-441.81-56						PROFESSIONAL SERVICES / EMPLOYEE WELLNESS PROG				
1039				07/23 AP	12/21/22 0000000	COMMUNITY MAIN STREET	700.00			01/10/23
						WELLNESS CHALLENGE PRIZES				20X\$35
						ACCOUNT TOTAL	700.00	.00		700.00
101-1038-441.83-04						TRANSPORTATION&EDUCATION / DUES & MEMBERSHIPS				
1113				07/23 AP	12/06/22 0142132	US BANK	215.00			01/06/23
						PELRA* INV-1538				MEMBERSHIP:2023 BALVANZ
						ACCOUNT TOTAL	215.00	.00		215.00
101-1038-441.83-05						TRANSPORTATION&EDUCATION / TRAVEL (FOOD/MILEAGE/LOD)				
1085				07/23 AP	12/28/22 0000000	SOCIAL ACTION, INC.	50.00			01/10/23
						MLK BANQUET TICKETS (1)				
						ACCOUNT TOTAL	50.00	.00		50.00
101-1048-441.71-01						OFFICE SUPPLIES / OFFICE SUPPLIES				
1085				07/23 AP	12/28/22 0000000	OFFICE EXPRESS OFFICE PRODUCT	6.08			01/10/23
						COPY PAPER				
1085				07/23 AP	12/01/22 0000000	STOREY KENWORTHY	2.30			01/10/23
						#10 REGULAR ENVELOPES				
						ACCOUNT TOTAL	8.38	.00		8.38
101-1048-441.72-11						OPERATING SUPPLIES / DUES, BOOKS, MAGAZINES				
1085				07/23 AP	01/01/23 0000000	THOMSON REUTERS - WEST	663.54			01/10/23
						WESTLAW INFORMATION				12/1/22-12/31/22
						ACCOUNT TOTAL	663.54	.00		663.54
101-1048-441.81-29						PROFESSIONAL SERVICES / LEGAL CONSULTANTS				
1085				07/23 AP	12/27/22 0000000	AHLERS AND COONEY, P.C.	390.00			01/10/23
						LGL:CONTESTED SERV. AREA				10/27-11/30/22

PREPARED 01/10/2023, 11:21:08
 PROGRAM GM360L
 CITY OF CEDAR FALLS

ACCOUNT ACTIVITY LISTING

PAGE 5
 ACCOUNTING PERIOD 06/2023

GROUP NBR	PO NBR	ACCTG PER.	CD	DATE	TRANSACTION NUMBER	DESCRIPTION	DEBITS	CREDITS	CURRENT BALANCE	POST DT
FUND 101 GENERAL FUND										
101-1048-441.81-29 PROFESSIONAL SERVICES / LEGAL CONSULTANTS						continued				
1085		07/23 AP		12/19/22	0000000	AHLERS AND COONEY, P.C.	157.50		01/10/23	
		LGL:LABOR RELATIONS				11/21-12/12/22				
1039		07/23 AP		12/16/22	0000000	DENTONS DAVIS BROWN PC	127.50		01/10/23	
		LGL:RE:IMMIGRATION								
ACCOUNT TOTAL							675.00	.00	675.00	
101-1060-423.71-01 OFFICE SUPPLIES / OFFICE SUPPLIES										
1114		07/23 AP		12/19/22	0142132	US BANK	223.99		01/06/23	
		QUADIEN INC ORACLE				INK FOR POSTAGE METER				
1114		07/23 AP		12/12/22	0142132	US BANK	7.99		01/06/23	
		AMZN MKTP US*763H88QM3				REFLECTIVE TAPE				
1114		07/23 AP		12/05/22	0142132	US BANK	3.49		01/06/23	
		AMAZON.COM*J043H6XR3 AMZN				PENS				
1114		07/23 AP		11/30/22	0142132	US BANK	5.61		01/06/23	
		SQ *POLK'S LOCK SERVICE				KEY DUPLICATION				
1114		07/23 AP		11/28/22	0142132	US BANK	15.90		01/06/23	
		AMZN MKTP US*HW4V22B81				INK STAMP PAD REPLACEMENT				
ACCOUNT TOTAL							256.98	.00	256.98	
101-1060-423.81-91 PROFESSIONAL SERVICES / LICENSES & SERVICE CONTRT										
1114		07/23 AP		12/12/22	0142132	US BANK	85.00		01/06/23	
		INTUIT *QBOOKS ONLINE				QUICKBOOKS MONTHLY SUB.				
ACCOUNT TOTAL							85.00	.00	85.00	
101-1060-423.89-20 MISCELLANEOUS SERVICES / ADULT BOOKS										
1114		07/23 AP		12/20/22	0142132	US BANK	42.51		01/06/23	
		AMZN MKTP US*HA80N19I1 AM				ADULT BOOKS (MEM BROWN)				
1114		07/23 AP		12/12/22	0142132	US BANK	60.93		01/06/23	
		AMAZON.COM*MK42Q9LN3				ADULT BOOKS (MEM BROWN)				
ACCOUNT TOTAL							103.44	.00	103.44	
101-1060-423.89-33 MISCELLANEOUS SERVICES / FRIENDS SUPPORTED PROGRAM										
1114		07/23 AP		12/20/22	0142132	US BANK	12.99		01/06/23	
		AMZN MKTP US*5N8122HN3				FOTL:YA-POCKY STICKS				
1114		07/23 AP		12/14/22	0142132	US BANK	29.49		01/06/23	
		AMZN MKTP US*HH81E1MJ1 AM				FOTL:YA-PANDA COOKIES				
1114		07/23 AP		12/14/22	0142132	US BANK	8.64		01/06/23	
		AMAZON.COM*7X1FN0OX3				FOTL:YOUTH-FAKE SNOW				
1114		07/23 AP		12/14/22	0142132	US BANK	40.94		01/06/23	
		AMZN MKTP US*HJ14Y3P53				FOTL:YA-SODAS				
1114		07/23 AP		12/05/22	0142132	US BANK	11.60		01/06/23	

PREPARED 01/10/2023, 11:21:08
PROGRAM GM360L
CITY OF CEDAR FALLS

ACCOUNT ACTIVITY LISTING

PAGE 6
ACCOUNTING PERIOD 06/2023

GROUP NBR	PO NBR	ACCTG PER.	CD	DATE	TRANSACTION NUMBER	DESCRIPTION	DEBITS	CREDITS	CURRENT BALANCE	POST DT
FUND 101 GENERAL FUND										
101-1060-423.89-33						MISCELLANEOUS SERVICES / FRIENDS SUPPORTED PROGRAM				continued
						AMAZON.COM*7C0ZM22G3				FOTL:YA-MINDFULNESS CARDS
1114				07/23	AP 12/05/22 0142132	US BANK	28.20			01/06/23
						WAL-MART #0753				FOTL:YOUTH-COTTON BALLS &
1114				07/23	AP 11/30/22 0142132	US BANK	29.99			01/06/23
						CHICAGO BOOKS & JOURNALS				FOTL:YOUTH-ALA CALENDAR
1114				07/23	AP 11/28/22 0142132	US BANK	13.99			01/06/23
						AMZN MKTP US*HW6IL3VH1				FOTL:YOUTH-RUBIK'S CUBE
1114				07/23	AP 11/25/22 0142132	US BANK	16.99			01/06/23
						AMZN MKTP US*HW3L91XIO				FOTL:YOUTH-RUBIK'S CUBE
1114				07/23	AP 11/25/22 0142132	US BANK	11.99			01/06/23
						AMZN MKTP US*HW49Y6XR0				FOTL:YOUTH-RUBIK'S CUBE
1114				07/23	AP 11/25/22 0142132	US BANK	51.78			01/06/23
						AMZN MKTP US*HW7XQ7VV0				FOTL:YOUTH-CRAFT POMPOMS
						ACCOUNT TOTAL	256.60	0.00		256.60
101-1061-423.89-20 MISCELLANEOUS SERVICES / ADULT BOOKS										
1114				07/23	AP 12/20/22 0142132	US BANK	23.99			01/06/23
						AMAZON.COM*623QI61C3 AMZN				ADULT BOOKS
1114				07/23	AP 12/20/22 0142132	US BANK	24.49			01/06/23
						AMAZON.COM*937DW1IL3 AMZN				ADULT BOOKS
1114				07/23	AP 12/19/22 0142132	US BANK	32.28			01/06/23
						AMZN MKTP US*G77H98GZ3 AM				ADULT BOOKS
1114				07/23	AP 12/19/22 0142132	US BANK	11.99			01/06/23
						AMAZON.COM*ZM8K43L33 AMZN				ADULT BOOKS
1114				07/23	AP 12/19/22 0142132	US BANK	16.99			01/06/23
						AMZN MKTP US*PI27Z3513				ADULT BOOKS
1114				07/23	AP 12/14/22 0142132	US BANK	37.86			01/06/23
						AMZN MKTP US*805414PN3				ADULT BOOKS
1114				07/23	AP 12/13/22 0142132	US BANK	13.54			01/06/23
						AMZN MKTP US*FU3AA52F3				ADULT BOOKS
1114				07/23	AP 12/12/22 0142132	US BANK	24.99			01/06/23
						AMAZON.COM*5E1KC4OQ3 AMZN				ADULT BOOKS
1114				07/23	AP 12/12/22 0142132	US BANK	33.38			01/06/23
						AMAZON.COM*055TM56L3 AMZN				ADULT BOOKS
1114				07/23	AP 12/12/22 0142132	US BANK	40.30			01/06/23
						AMAZON.COM*MK42Q9LN3				ADULT BOOKS
1114				07/23	AP 12/12/22 0142132	US BANK	15.97			01/06/23
						AMAZON.COM*126TR7TM3				ADULT BOOKS
1114				07/23	AP 12/05/22 0142132	US BANK	14.99			01/06/23
						AMAZON.COM*M86XB00F3				ADULT BOOKS
1114				07/23	AP 12/05/22 0142132	US BANK	14.99			01/06/23
						AMAZON.COM*LJ6B04FY3				ADULT BOOKS
1114				07/23	AP 12/05/22 0142132	US BANK	11.99			01/06/23
						AMZN MKTP US*VH3TT2KK3				ADULT BOOKS
1114				07/23	AP 12/01/22 0142132	US BANK	18.00			01/06/23
						AMAZON.COM*3H82H7FT3				ADULT BOOKS
1114				07/23	AP 11/28/22 0142132	US BANK	54.93			01/06/23

PREPARED 01/10/2023, 11:21:08
 PROGRAM GM360L
 CITY OF CEDAR FALLS

ACCOUNT ACTIVITY LISTING

PAGE 7
 ACCOUNTING PERIOD 06/2023

GROUP NBR	PO NBR	ACCTG PER.	CD	DATE	TRANSACTION NUMBER	DESCRIPTION	DEBITS	CREDITS	CURRENT BALANCE	POST DT
FUND 101 GENERAL FUND										
101-1061-423.89-20						MISCELLANEOUS SERVICES / ADULT BOOKS				continued
1114				07/23	AP 11/28/22 0142132	AMAZON.COM*HW66Z0TK2 AMZN ADULT BOOKS	19.49		01/06/23	
1114				07/23	AP 11/28/22 0142132	AMZN MKTP US*HW8ZL5KT0 ADULT BOOKS	10.19		01/06/23	
1114				07/23	AP 11/25/22 0142132	AMAZON.COM*HW6HJ0BA1 ADULT BOOKS	8.37		01/06/23	
1114				07/23	AP 11/25/22 0142132	AMAZON.COM*HW3701SW0 AMZN ADULT BOOKS	21.81		01/06/23	
						AMAZON.COM*HW7PU5S40 AMZN ADULT BOOKS				
						ACCOUNT TOTAL	450.54	.00	450.54	
101-1061-423.89-21 MISCELLANEOUS SERVICES / YOUNG ADULT BOOKS										
1114				07/23	AP 12/12/22 0142132	AMAZON.COM*5E1KC4OQ3 AMZN YOUNG ADULT BOOKS	14.45		01/06/23	
1114				07/23	AP 12/05/22 0142132	AMAZON.COM*GG1W39823 YOUNG ADULT BOOKS	9.99		01/06/23	
						ACCOUNT TOTAL	24.44	.00	24.44	
101-1061-423.89-22 MISCELLANEOUS SERVICES / YOUTH BOOKS										
1114				07/23	AP 12/19/22 0142132	AMAZON.COM*FT1BN7PT3 AMZN YOUTH BOOKS	17.37		01/06/23	
1114				07/23	AP 12/19/22 0142132	AMAZON.COM*HL46P0W33 AMZN YOUTH BOOKS	26.99		01/06/23	
1114				07/23	AP 12/19/22 0142132	AMZN MKTP US*3M63Q38M3 YOUTH BOOKS	22.02		01/06/23	
1114				07/23	AP 12/14/22 0142132	AMAZON.COM*O04IC4IM3 AMZN YOUTH BOOKS	31.98		01/06/23	
1114				07/23	AP 12/14/22 0142132	AMAZON.COM*H650T3WR3 AMZN YOUTH BOOKS	30.07		01/06/23	
1114				07/23	AP 12/14/22 0142132	AMZN MKTP US*8A90E9IO3 YOUTH BOOKS	25.09		01/06/23	
1114				07/23	AP 12/12/22 0142132	AMAZON.COM*GU5G059V3 YOUTH BOOKS	99.99		01/06/23	
1114				07/23	AP 12/06/22 0142132	AMAZON.COM*6Y1Z562Y3 AMZN YOUTH BOOKS	4.99		01/06/23	
1114				07/23	AP 12/05/22 0142132	AMAZON.COM*ME0A179G3 AMZN YOUTH BOOKS	110.83		01/06/23	
1114				07/23	AP 12/05/22 0142132	AMZN MKTP US*Y49IQ67X3 YOUTH BOOKS	9.93		01/06/23	
1114				07/23	AP 12/01/22 0142132	AMAZON.COM*090YG8D23 AMZN YOUTH BOOKS	18.98		01/06/23	
1114				07/23	AP 12/01/22 0142132	AMZN MKTP US*HZ2RH9CH2 YOUTH BOOKS	20.89		01/06/23	
1114				07/23	AP 11/28/22 0142132	AMAZON.COM*HW66Z0TK2 AMZN YOUTH BOOKS	9.04		01/06/23	

PREPARED 01/10/2023, 11:21:08
 PROGRAM GM360L
 CITY OF CEDAR FALLS

ACCOUNT ACTIVITY LISTING

PAGE 8
 ACCOUNTING PERIOD 06/2023

GROUP NBR	PO NBR	ACCTG PER.	CD	DATE	TRANSACTION NUMBER	DESCRIPTION	DEBITS	CREDITS	CURRENT BALANCE	POST DT
FUND 101 GENERAL FUND										
101-1061-423.89-22 MISCELLANEOUS SERVICES / YOUTH BOOKS						continued				
ACCOUNT TOTAL							428.17	.00	428.17	
101-1061-423.89-25 MISCELLANEOUS SERVICES / ADULT VIDEO										
1114		07/23 AP		11/28/22	0142132	US BANK	11.56			01/06/23
AMZN MKTP US*HW8ZL5KT0 ADULT VIDEOS										
ACCOUNT TOTAL							11.56	.00	11.56	
101-1061-423.89-36 MISCELLANEOUS SERVICES / YOUTH VIDEO										
1114		07/23 AP		12/19/22	0142132	US BANK	18.89			01/06/23
AMZN MKTP US*WC2217C43 YOUTH VIDEOS										
1114		07/23 AP		12/07/22	0142132	US BANK	10.99			01/06/23
AMZN MKTP US*7B2TY4ZH3 YOUTH VIDEOS										
1114		07/23 AP		12/05/22	0142132	US BANK	22.50			01/06/23
AMAZON.COM*WJ4J70GW3 AMZN YOUTH VIDEOS										
ACCOUNT TOTAL							52.38	.00	52.38	
101-1061-423.89-37 MISCELLANEOUS SERVICES / YOUNG ADULT AUDIO										
1114		07/23 AP		12/12/22	0142132	US BANK	57.71			01/06/23
AMAZON.COM*5E1KC4OQ3 AMZN YOUNG ADULT CD BOOKS										
ACCOUNT TOTAL							57.71	.00	57.71	
101-1061-423.89-38 MISCELLANEOUS SERVICES / YOUNG ADULT VIDEO										
1114		07/23 AP		12/14/22	0142132	US BANK	93.77			01/06/23
AMZN MKTP US*DX31I7UC3 YOUNG ADULT VIDEOS										
ACCOUNT TOTAL							93.77	.00	93.77	
101-1061-423.89-47 MISCELLANEOUS SERVICES / LIBRARY OF THINGS										
1114		07/23 AP		12/12/22	0142132	US BANK	33.98			01/06/23
AMZN MKTP US*157BE1N63 EXTERNAL CD DRIVE & CASE										
1114		07/23 AP		12/05/22	0142132	US BANK	32.79			01/06/23
AMAZON.COM*E526M4FZ3 AMZN INDEX CARD CASES										
ACCOUNT TOTAL							66.77	.00	66.77	
101-1118-441.71-01 OFFICE SUPPLIES / OFFICE SUPPLIES										
1085		07/23 AP		12/28/22	0000000	OFFICE EXPRESS OFFICE PRODUCT	3.04			01/10/23
COPY PAPER										
1085		07/23 AP		12/01/22	0000000	STOREY KENWORTHY	2.30			01/10/23

PREPARED 01/10/2023, 11:21:08
 PROGRAM GM360L
 CITY OF CEDAR FALLS

ACCOUNT ACTIVITY LISTING

PAGE 9
 ACCOUNTING PERIOD 06/2023

GROUP NBR	PO NBR	ACCTG PER.	CD	---TRANSACTION--- DATE	NUMBER	DESCRIPTION	DEBITS	CREDITS	CURRENT BALANCE	POST DT
FUND 101 GENERAL FUND										
101-1118-441.71-01 OFFICE SUPPLIES / OFFICE SUPPLIES						continued				
#10 REGULAR ENVELOPES										
ACCOUNT TOTAL							5.34	.00	5.34	
101-1118-441.81-98 PROFESSIONAL SERVICES / ECONOMIC DEVELOPMENT ACT.										
1113		07/23 AP		12/08/22	0142132	US BANK		50.94		01/06/23
						REFUNDED TO REMOVE TAX				
1113		07/23 AP		12/07/22	0142132	US BANK	50.94			01/06/23
						WM SUPERCENTER #753				
						12/6/22 IEDA CERT. EVENT				
1113		07/23 AP		12/06/22	0142132	US BANK	50.94			01/06/23
						WM SUPERCENTER #753				
						12/6/22 IEDA CERT. EVENT				
1113		07/23 AP		12/05/22	0142132	US BANK	72.00			01/06/23
						SQ *SCRATCH CUPCAKERY				
						12/6/22 IEDA CERT. EVENT				
ACCOUNT TOTAL							173.88	50.94	122.94	
101-1118-441.83-05 TRANSPORTATION&EDUCATION / TRAVEL (FOOD/MILEAGE/LOD)										
1113		07/23 AP		11/25/22	0142132	US BANK	10.72			01/06/23
						QUICK CONNECT C06 ORD				
						MEAL:LUNCH 11/22/22				
1113		07/23 AP		11/25/22	0142132	US BANK	170.61			01/06/23
						NH CITY CENTRE				
						AMSTERDAM HOTEL TAXES				
1113		07/23 AP		11/23/22	0142132	US BANK	70.00			01/06/23
						EASTERN IOWA AIRPORT PARK				
						PRKING-EASTERN IA AIRPORT				
1113		07/23 AP		11/23/22	0142132	US BANK	72.04			01/06/23
						SUMUP *TAXI FRINDI				
						SUMUP TAXI-AMSWERDAM				
1113		07/23 AP		11/22/22	0142132	US BANK	9.06			01/06/23
						GVB VOERTUIG T2120CC				
						DAILY TRAM TICKET				
1113		07/23 AP		11/22/22	0142132	US BANK	24.78			01/06/23
						NS AMSTERDAM CENTRAAL				
						AMSTERDAM TRAIN STATION				
ACCOUNT TOTAL							357.21	.00	357.21	
101-1118-441.83-06 TRANSPORTATION&EDUCATION / EDUCATION										
1085		07/23 AP		09/14/22	0000000	GROW CEDAR VALLEY	1,850.00			01/10/23
						REG:CVLI-AMANDA HUISMAN				
						WATERLOO				
ACCOUNT TOTAL							1,850.00	.00	1,850.00	
101-1158-441.71-01 OFFICE SUPPLIES / OFFICE SUPPLIES										
1085		07/23 AP		12/28/22	0000000	OFFICE EXPRESS OFFICE PRODUCT	3.04			01/10/23
						COPY PAPER				
1085		07/23 AP		12/01/22	0000000	STOREY KENWORTHY	2.30			01/10/23
						#10 REGULAR ENVELOPES				
ACCOUNT TOTAL							5.34	.00	5.34	

PREPARED 01/10/2023, 11:21:08
 PROGRAM GM360L
 CITY OF CEDAR FALLS

ACCOUNT ACTIVITY LISTING

PAGE 10
 ACCOUNTING PERIOD 06/2023

GROUP NBR	PO NBR	ACCTG PER.	CD	DATE	TRANSACTION NUMBER	DESCRIPTION	DEBITS	CREDITS	CURRENT BALANCE	POST DT
FUND 101 GENERAL FUND										
101-1158-441.83-04						TRANSPORTATION&EDUCATION / DUES & MEMBERSHIPS				
1039		07/23 AP		12/20/22	0000000	COMMUNITY FOUNDATION-METRO FU ANNUAL DUES FOR 2023	100.00			01/10/23
						ACCOUNT TOTAL	100.00	.00	100.00	
101-1158-441.83-05 TRANSPORTATION&EDUCATION / TRAVEL (FOOD/MILEAGE/LOD)										
101-1158-441.83-05						TRANSPORTATION&EDUCATION / TRAVEL (FOOD/MILEAGE/LOD)				
1085		07/23 AP		12/28/22	0000000	SOCIAL ACTION, INC. MLK BANQUET TICKETS (1)	50.00			01/10/23
						ACCOUNT TOTAL	50.00	.00	50.00	
101-1158-441.93-01 EQUIPMENT / EQUIPMENT										
101-1158-441.93-01						EQUIPMENT / EQUIPMENT				
1113		07/23 AP		12/15/22	0142132	US BANK ASHLEY HOME STORE - 78 MAYOR'S OFFICE FURNITURE	1,828.96			01/06/23
						ACCOUNT TOTAL	1,828.96	.00	1,828.96	
101-1199-421.31-12 HUMAN DEVELOPMENT GRANTS / GRANTS-CULT IAC GEN OP										
101-1199-421.31-12						HUMAN DEVELOPMENT GRANTS / GRANTS-CULT IAC GEN OP				
1110		07/23 AP		12/27/22	0000000	SIGNS BY TOMORROW EXHIBITION.	240.00			01/10/23
1110		07/23 AP		12/15/22	0000000	LABELS FOR BULGARIAN ROSE ECHEVERRIA, FRJE INSTRUCTION FOR A 4 PART WORKSHOP	700.00			01/10/23
						ACCOUNT TOTAL	940.00	.00	940.00	
101-1199-431.88-01 OUTSIDE AGENCIES / MET - CF DISABLED										
101-1199-431.88-01						OUTSIDE AGENCIES / MET - CF DISABLED				
1039		07/23 AP		01/01/23	0000000	METROPOLITAN TRANSIT AUTHORIT PAYMENT FOR FY23-3RD QTR	9,057.50			01/10/23
						ACCOUNT TOTAL	9,057.50	.00	9,057.50	
101-1199-431.88-02 OUTSIDE AGENCIES / MET-RTC										
101-1199-431.88-02						OUTSIDE AGENCIES / MET-RTC				
1039		07/23 AP		01/01/23	0000000	METROPOLITAN TRANSIT AUTHORIT PAYMENT FOR FY23-3RD QTR	6,035.00			01/10/23
						ACCOUNT TOTAL	6,035.00	.00	6,035.00	
101-1199-431.88-11 OUTSIDE AGENCIES / MET TRANSIT AUTHORITY										
101-1199-431.88-11						OUTSIDE AGENCIES / MET TRANSIT AUTHORITY				
1039		07/23 AP		01/01/23	0000000	METROPOLITAN TRANSIT AUTHORIT PAYMENT FOR FY23-3RD QTR	85,765.00			01/10/23
						ACCOUNT TOTAL	85,765.00	.00	85,765.00	

PREPARED 01/10/2023, 11:21:08
 PROGRAM GM360L
 CITY OF CEDAR FALLS

ACCOUNT ACTIVITY LISTING

PAGE 11
 ACCOUNTING PERIOD 06/2023

GROUP NBR	PO NBR	ACCTG PER.	CD	DATE	TRANSACTION NUMBER	DESCRIPTION	DEBITS	CREDITS	CURRENT BALANCE	POST DT
FUND 101 GENERAL FUND										
101-1199-1039	431.88-12	07/23 AP	01/01/23	0000000	0000000	OUTSIDE AGENCIES / MET CAPITAL REPLACEMENT VEHICLE MAINTENANCE FUND PAYMENT FOR FY23-3RD QTR	4,230.00		01/10/23	
ACCOUNT TOTAL							4,230.00	.00	4,230.00	
101-1199-1039	431.88-19	07/23 AP	01/01/23	0000000	0000000	OUTSIDE AGENCIES / MET-ROUTE 9 METROPOLITAN TRANSIT AUTHORIT PAYMENT FOR FY23-3RD QTR	8,937.50		01/10/23	
ACCOUNT TOTAL							8,937.50	.00	8,937.50	
101-1199-1085	441.72-19	07/23 AP	12/22/22	0000000	0000000	OPERATING SUPPLIES / PRINTING COURIER LEGAL COMMUNICATIONS	75.04		01/10/23	
101-1039		07/23 AP	12/21/22	0000000	0000000	PH NTC.-SW CF URBAN RENEW CIVICPLUS	4,516.40		01/10/23	
101-1085		07/23 AP	12/21/22	0000000	0000000	CODE SUPPL. ANNL. SUBSCR. 12/19/22-12/18/23 COURIER LEGAL COMMUNICATIONS	35.22		01/10/23	
101-1085		07/23 AP	12/14/22	0000000	0000000	PH NTC. CIP 2023 COURIER LEGAL COMMUNICATIONS	320.74		01/10/23	
101-1085		07/23 AP	12/09/22	0000000	0000000	MINUTES/RECEIPTS 12/5 MTG COURIER LEGAL COMMUNICATIONS	36.39		01/10/23	
101-1085		07/23 AP	12/09/22	0000000	0000000	PH NTC.-PERM. CFU EASEMT. COURIER LEGAL COMMUNICATIONS	93.77		01/10/23	
101-1085		07/23 AP	12/02/22	0000000	0000000	ORDINANCE #3020 COURIER LEGAL COMMUNICATIONS	488.80		01/10/23	
ACCOUNT TOTAL							5,566.36	.00	5,566.36	
101-1199-1085	441.88-20	07/23 AP	01/01/23	0000000	0000000	OUTSIDE AGENCIES / LOBBYIST COPE MURPHY+CO LLP LOBBYING FEE-JANUARY 2023	4,500.00		01/10/23	
ACCOUNT TOTAL							4,500.00	.00	4,500.00	
101-1042	2205-432.71-01	07/23 AP	12/29/22	0000000	0000000	OFFICE SUPPLIES / OFFICE SUPPLIES OFFICE EXPRESS OFFICE PRODUCT	.14		01/10/23	
101-1042		07/23 AP	12/20/22	0000000	0000000	MASKING TAPE OFFICE EXPRESS OFFICE PRODUCT	.54		01/10/23	
101-1042		07/23 AP	12/19/22	0000000	0000000	ENVELOPES, GLUE STICKS OFFICE EXPRESS OFFICE PRODUCT	1.22		01/10/23	
101-1042		07/23 AP	12/19/22	0000000	0000000	LEGAL PAPER OFFICE EXPRESS OFFICE PRODUCT	6.29		01/10/23	
ACCOUNT TOTAL							8.19	.00	8.19	

PREPARED 01/10/2023, 11:21:08
 PROGRAM GM360L
 CITY OF CEDAR FALLS

ACCOUNT ACTIVITY LISTING

PAGE 12
 ACCOUNTING PERIOD 06/2023

GROUP NBR	PO NBR	ACCTG PER.	CD	DATE	---TRANSACTION--- NUMBER	DESCRIPTION	DEBITS	CREDITS	CURRENT BALANCE	POST DT
FUND 101 GENERAL FUND										
101-2205-432.72-01 OPERATING SUPPLIES / OPERATING SUPPLIES										
1042		07/23 AP		12/28/22	0000000	OFFICE EXPRESS OFFICE PRODUCT	.43			01/10/23
						TAPE, PUTTY				
1042		07/23 AP		12/19/22	0000000	OFFICE EXPRESS OFFICE PRODUCT	.08			01/10/23
						PENS				
ACCOUNT TOTAL							.51	.00	.51	
101-2205-432.72-19 OPERATING SUPPLIES / PRINTING										
1085		07/23 AP		12/01/22	0000000	STOREY KENWORTHY	2.30			01/10/23
						#10 REGULAR ENVELOPES				
ACCOUNT TOTAL							2.30	.00	2.30	
101-2205-432.88-10 OUTSIDE AGENCIES / BLACK HAWK COUNTY HEALTH										
1039		07/23 AP		01/01/23	0000000	BLACK HAWK CO.HEALTH DEPT.	3,250.00			01/10/23
						PAYMENT FOR FY23-3RD QTR				
ACCOUNT TOTAL							3,250.00	.00	3,250.00	
101-2205-432.88-38 OUTSIDE AGENCIES / CEDAR VALLEY SOCCER										
1039		07/23 AP		01/01/23	0000000	CEDAR VALLEY YOUTH SOCCER ASS	2,500.00			01/10/23
						PAYMENT FOR FY23-3RD QTR				
ACCOUNT TOTAL							2,500.00	.00	2,500.00	
101-2235-412.71-01 OFFICE SUPPLIES / OFFICE SUPPLIES										
1042		07/23 AP		12/29/22	0000000	OFFICE EXPRESS OFFICE PRODUCT	1.16			01/10/23
						MASKING TAPE				
1042		07/23 AP		12/28/22	0000000	OFFICE EXPRESS OFFICE PRODUCT	3.61			01/10/23
						TAPE, PUTTY				
1042		07/23 AP		12/20/22	0000000	OFFICE EXPRESS OFFICE PRODUCT	4.53			01/10/23
						ENVELOPES, GLUE STICKS				
1042		07/23 AP		12/19/22	0000000	OFFICE EXPRESS OFFICE PRODUCT	4.36			01/10/23
						LEGAL PAPER				
1042		07/23 AP		12/19/22	0000000	OFFICE EXPRESS OFFICE PRODUCT	22.48			01/10/23
						COPY PAPER				
1042		07/23 AP		12/19/22	0000000	OFFICE EXPRESS OFFICE PRODUCT	.64			01/10/23
						PENS				
1085		07/23 AP		12/01/22	0000000	STOREY KENWORTHY	11.50			01/10/23
						#10 REGULAR ENVELOPES				
ACCOUNT TOTAL							48.28	.00	48.28	
101-2235-412.72-17 OPERATING SUPPLIES / UNIFORMS										

PREPARED 01/10/2023, 11:21:08
 PROGRAM GM360L
 CITY OF CEDAR FALLS

ACCOUNT ACTIVITY LISTING

PAGE 13
 ACCOUNTING PERIOD 06/2023

GROUP NBR	PO NBR	ACCTG PER.	CD	DATE	TRANSACTION NUMBER	DESCRIPTION	DEBITS	CREDITS	CURRENT BALANCE	POST DT
FUND 101 GENERAL FUND										
101-2235-412.72-17 OPERATING SUPPLIES / UNIFORMS						continued				
1042		07/23	AP	12/28/22	0000000	SERVICEWEAR APPAREL, INC. UNIFORMS-J CRAIG	40.76			01/10/23
		ACCOUNT TOTAL					40.76	.00	40.76	
101-2235-412.83-06 TRANSPORTATION&EDUCATION / EDUCATION										
1113		07/23	AP	12/15/22	0142132	US BANK	19.95			01/06/23
1113		07/23	AP	12/15/22	0142132	US BANK	19.95			01/06/23
1113		07/23	AP	12/15/22	0142132	US BANK	19.95			01/06/23
1113		07/23	AP	12/15/22	0142132	US BANK	45.00			01/06/23
		ACCOUNT TOTAL					104.85	.00	104.85	
101-2245-442.71-01 OFFICE SUPPLIES / OFFICE SUPPLIES										
1042		07/23	AP	12/29/22	0000000	OFFICE EXPRESS OFFICE PRODUCT MASKING TAPE	.65			01/10/23
1042		07/23	AP	12/20/22	0000000	OFFICE EXPRESS OFFICE PRODUCT ENVELOPES, GLUE STICKS	2.54			01/10/23
1042		07/23	AP	12/19/22	0000000	OFFICE EXPRESS OFFICE PRODUCT LEGAL PAPER	3.49			01/10/23
1042		07/23	AP	12/19/22	0000000	OFFICE EXPRESS OFFICE PRODUCT COPY PAPER	17.98			01/10/23
1042		07/23	AP	12/19/22	0000000	OFFICE EXPRESS OFFICE PRODUCT PENS	.36			01/10/23
		ACCOUNT TOTAL					25.02	.00	25.02	
101-2245-442.72-01 OPERATING SUPPLIES / OPERATING SUPPLIES										
1042		07/23	AP	12/28/22	0000000	OFFICE EXPRESS OFFICE PRODUCT TAPE,PUTTY	2.02			01/10/23
		ACCOUNT TOTAL					2.02	.00	2.02	
101-2245-442.72-19 OPERATING SUPPLIES / PRINTING										
1085		07/23	AP	12/07/22	0000000	COURIER LEGAL COMMUNICATIONS	45.76			01/10/23
1085		07/23	AP	12/07/22	0000000	COURIER LEGAL COMMUNICATIONS	39.91			01/10/23
1085		07/23	AP	12/01/22	0000000	STOREY KENWORTHY	34.50			01/10/23
		ACCOUNT TOTAL					120.17	.00	120.17	

PREPARED 01/10/2023, 11:21:08
 PROGRAM GM360L
 CITY OF CEDAR FALLS

ACCOUNT ACTIVITY LISTING

PAGE 14
 ACCOUNTING PERIOD 06/2023

GROUP	PO	ACCTG	----	TRANSACTION	----					
NBR	NBR	PER.	CD	DATE	NUMBER	DESCRIPTION	DEBITS	CREDITS	CURRENT	POST DT
									BALANCE	----
FUND 101 GENERAL FUND										
101-2245-442.83-04						TRANSPORTATION&EDUCATION / DUES & MEMBERSHIPS				
1113		07/23 AP		12/08/22	0142132	US BANK	40.00		01/06/23	
		CLB*IFSMA				DUES/MEMBERSHIPS				
					ACCOUNT TOTAL		40.00	.00	40.00	
101-2253-423.71-01 OFFICE SUPPLIES / OFFICE SUPPLIES										
1113		07/23 AP		12/09/22	0142132	US BANK	324.75		01/06/23	
		AMZN MKTP			US*5J6AU3JJ3	OFFICE CARDS				
1113		07/23 AP		12/07/22	0142132	US BANK	77.92		01/06/23	
		AMZN MKTP			US*EE31O2283	PRINTER CARDS				
					ACCOUNT TOTAL		402.67	.00	402.67	
101-2253-423.72-30 OPERATING SUPPLIES / REC CENTER EQUIP. & SUPP.										
1113		07/23 AP		12/09/22	0142132	US BANK	97.99		01/06/23	
		AMZN MKTP			US*5J6AU3JJ3	REC SUPPLIES				
1113		07/23 AP		12/09/22	0142132	US BANK	35.44		01/06/23	
		AMZN MKTP			US*5J6AU3JJ3	REC SUPPLIES				
					ACCOUNT TOTAL		133.43	.00	133.43	
101-2253-423.72-32 OPERATING SUPPLIES / ADULT SPORTS EQUIPMENT										
1113		07/23 AP		12/05/22	0142132	US BANK	5.69		01/06/23	
		O DONNELL			ACE HARDWARE	PICKLEBALL SUPPLIES				
1113		07/23 AP		11/22/22	0142132	US BANK	79.00		01/06/23	
		STICKER MULE				RACQUETBALL LEAGUE				
					ACCOUNT TOTAL		84.69	.00	84.69	
101-2253-423.72-44 OPERATING SUPPLIES / EXERCISE EQUIP. REPAIRS										
1113		07/23 AP		12/06/22	0142132	US BANK	84.80		01/06/23	
		BLT*PCL			LIQUIDATIONS.COM	REPLACEMENT MONITOR				
1113		07/23 AP		11/28/22	0142132	US BANK	56.49		01/06/23	
		AMZN MKTP			US*HW0M19610	REPLACEMENT MONITOR				
					ACCOUNT TOTAL		141.29	.00	141.29	
101-2253-423.72-47 OPERATING SUPPLIES / ADULT EXERCISE EQUIP										
1113		07/23 AP		12/13/22	0142132	US BANK	89.71		01/06/23	
		SPORTSMITH			LLC	BOTTOM BRACKET &				
1113		07/23 AP		12/13/22	0142132	US BANK	199.00		01/06/23	
		BLUE GOJI			LLC	2023 SOFTWARE LIC.				
1113		07/23 AP		12/13/22	0142132	US BANK	199.00		01/06/23	
		BLUE GOJI			LLC	2023 SOFTWARE LIC				

PREPARED 01/10/2023, 11:21:08
 PROGRAM GM360L
 CITY OF CEDAR FALLS

ACCOUNT ACTIVITY LISTING

PAGE 15
 ACCOUNTING PERIOD 06/2023

GROUP NBR	PO NBR	ACCTG PER.	CD	---TRANSACTION--- DATE	NUMBER	DESCRIPTION	DEBITS	CREDITS	CURRENT BALANCE POST DT
FUND 101 GENERAL FUND									
101-2253-423.72-47 OPERATING SUPPLIES / ADULT EXERCISE EQUIP						continued			
1113		07/23	AP	12/13/22	0142132	US BANK	199.00		01/06/23
						BLUE GOJI LLC		2023 SOFTWARE LIC	
1113		07/23	AP	12/01/22	0142132	US BANK	613.09		01/06/23
						JOHNSON HLTH TECH-CRP		WEIGHT MACHINE HANDLES	
1113		07/23	AP	11/30/22	0142132	US BANK	28.95		01/06/23
						WAL-MART #0753		REPLACEMENT CHARGING CORD	
						ACCOUNT TOTAL	1,328.75	.00	1,328.75
101-2253-423.73-55 OTHER SUPPLIES / MEDIA									
1122		07/23	AP	12/26/22	0000000	ICAN, INC.	200.00		01/10/23
						COMMERCIALS			
1113		07/23	AP	12/19/22	0142132	US BANK	5.02		01/06/23
						FACEBK *WNSHBUXQ72		FACEBOOK	
1113		07/23	AP	12/16/22	0142132	US BANK	25.00		01/06/23
						FACEBK *HA6J7NPR72		FACEBOOK	
1113		07/23	AP	12/12/22	0142132	US BANK	24.99		01/06/23
						FACEBK *PM7RUJQP72		FACEBOOK	
						ACCOUNT TOTAL	255.01	.00	255.01
101-2253-423.83-04 TRANSPORTATION&EDUCATION / DUES & MEMBERSHIPS									
1113		07/23	AP	12/02/22	0142132	US BANK	180.00		01/06/23
						IOWA PARK AND RECREATION		MEMBERSHIP DUES	
						ACCOUNT TOTAL	180.00	.00	180.00
101-2253-423.83-06 TRANSPORTATION&EDUCATION / EDUCATION									
1113		07/23	AP	11/29/22	0142132	US BANK	270.00		01/06/23
						IOWA PARK AND RECREATION		2023 CPO-CEU CLASS	
						ACCOUNT TOTAL	270.00	.00	270.00
101-2253-423.85-01 UTILITIES / UTILITIES									
1122		07/23	AP	11/01/22	0000000	IOWA WATER MANAGEMENT CORP. (58.00		01/10/23
						WATER MANAGEMENT SERVICE			
						ACCOUNT TOTAL	58.00	.00	58.00
101-2253-423.86-30 REPAIR & MAINTENANCE / MAINTENANCE & UPKEEP									
1122		07/23	AP	12/31/22	0000000	CULLIGAN WATER CONDITIONING	606.37		01/10/23
						REPAIR & MONTHLY DELIVERY			
1038		07/23	AP	12/23/22	0000000	ARAMARK	26.25		01/10/23
						REC CTR MATS			

PREPARED 01/10/2023, 11:21:08
 PROGRAM GM360L
 CITY OF CEDAR FALLS

ACCOUNT ACTIVITY LISTING

PAGE 16
 ACCOUNTING PERIOD 06/2023

GROUP NBR	PO NBR	ACCTG PER.	CD	DATE	TRANSACTION NUMBER	DESCRIPTION	DEBITS	CREDITS	CURRENT BALANCE	POST DT	
FUND 101 GENERAL FUND											
101-2253-423.86-30 REPAIR & MAINTENANCE / MAINTENANCE & UPKEEP						continued					
1113		07/23 AP		12/14/22	0142132	US BANK	16.69			01/06/23	
		O DONNELL ACE HARDWARE				THERMOMETER CYCLING ROOM					
1113		07/23 AP		12/12/22	0142132	US BANK	45.95			01/06/23	
		AMZN MKTP US*Z70QS2SP3				SNOW BRUSHES					
1113		07/23 AP		12/12/22	0142132	US BANK	11.38			01/06/23	
		O DONNELL ACE HARDWARE				ICE MELTS SCOOPS					
1113		07/23 AP		12/06/22	0142132	US BANK	9.99			01/06/23	
		O DONNELL ACE HARDWARE				2032 BATTERIES FOR FRONT					
1113		07/23 AP		11/23/22	0142132	US BANK	15.91			01/06/23	
		AMZN MKTP US*HI7R06D72				MENS LR SCALE CORD					
1113		07/23 AP		11/22/22	0142132	US BANK		9.99		01/06/23	
		AMZN MKTP US				RETURNED POWER CORD					
		ACCOUNT TOTAL						732.54	9.99		722.55
101-2253-423.86-31 REPAIR & MAINTENANCE / THE FALLS REPAIR & MAINT.											
1113		07/23 AP		12/05/22	0142132	US BANK	595.00			01/06/23	
		PK SAFETY SUPPLY				NEW 4-GAS DETECTOR					
1094		07/23 AP		11/30/22	0000000	NAPA AUTO PARTS	140.70			01/10/23	
		NAPA PARTS									
1113		07/23 AP		11/23/22	0142132	US BANK	39.44			01/06/23	
		O DONNELL ACE HARDWARE				FALLS DUMPSTER LOCKS/					
		ACCOUNT TOTAL						775.14	.00		775.14
101-2280-423.71-01 OFFICE SUPPLIES / OFFICE SUPPLIES											
1113		07/23 AP		12/19/22	0142132	US BANK	33.98			01/06/23	
		AMZN MKTP US*BR2GX1WC3				DRY ERASE MARKERS, STORAGE					
		ACCOUNT TOTAL						33.98	.00		33.98
101-2280-423.72-70 OPERATING SUPPLIES / CLASSROOM SUPPLIES											
1113		07/23 AP		12/05/22	0142132	US BANK	29.17			01/06/23	
		MICHAELS STORES 1246				FACE PAINT, BRUSHES					
1113		07/23 AP		12/02/22	0142132	US BANK	75.92			01/06/23	
		HOBBY-LOBBY #0135				PAINT, CLAY PTOS, BEADS					
1113		07/23 AP		12/01/22	0142132	US BANK	74.81			01/06/23	
		WM SUPERCENTER #753				EYES, FOLDERS, BABYWIPES					
		ACCOUNT TOTAL						179.90	.00		179.90
101-2280-423.72-71 OPERATING SUPPLIES / GALLERY SUPPLIES											
1110		07/23 AP		01/03/23	0000000	SIGNS BY TOMORROW	55.00			01/10/23	
		LABELS FOR PERMANENT				COLLECTION DRAWINGS					
		ACCOUNT TOTAL						55.00	.00		55.00

PREPARED 01/10/2023, 11:21:08
 PROGRAM GM360L
 CITY OF CEDAR FALLS

ACCOUNT ACTIVITY LISTING

PAGE 17
 ACCOUNTING PERIOD 06/2023

GROUP NBR	PO NBR	ACCTG PER.	CD	---TRANSACTION--- DATE	NUMBER	DESCRIPTION	DEBITS	CREDITS	CURRENT BALANCE POST DT
FUND 101 GENERAL FUND									
101-2280-423.73-01 OTHER SUPPLIES / REPAIR & MAINT. SUPPLIES									
1110	07/23	AP	01/03/23	0000000		O'DONNELL ACE HARDWARE	42.93		01/10/23
						BUCKETS AND LIDS FOR CERAMICS LAB			
1110	07/23	AP	12/22/22	0000000		NOVALYNK CORPORATION	181.36		01/10/23
						PENS FOR PERMENANT COLLEC HUMIDITY MONITORING			
1113	07/23	AP	12/14/22	0142132		US BANK	8.69		01/06/23
						O DONNELL ACE HARDWARE WORK GLOVES			
						ACCOUNT TOTAL	232.98	.00	232.98
101-2280-423.81-01 PROFESSIONAL SERVICES / PROFESSIONAL SERVICES									
1110	07/23	AP	12/23/22	0000000		ARAMARK	13.74		01/10/23
						RUG SERVICE			
						ACCOUNT TOTAL	13.74	.00	13.74
101-2280-423.81-60 PROFESSIONAL SERVICES / EXHIBITION FEES									
1113	07/23	AP	12/20/22	0142132		US BANK	930.50		01/06/23
						WHITE HOUSE CUSTOM COLOUR FINE ART PRINTS OF THE			
						ACCOUNT TOTAL	930.50	.00	930.50
101-2280-423.81-61 PROFESSIONAL SERVICES / PROMOTIONS									
1113	07/23	AP	12/05/22	0142132		US BANK	50.71		01/06/23
						FACEBK CANLGKKYN2 NOVEMBER PROGRAM AND			
						ACCOUNT TOTAL	50.71	.00	50.71
101-2280-423.89-33 MISCELLANEOUS SERVICES / FRIENDS SUPPORTED PROGRAM									
1110	07/23	AP	01/03/23	0000000		KAREN'S PRINT-RITE	297.00		01/10/23
						ANNUAL CAMPAIGN SECOND TOUCH POSTCARD			
1110	07/23	AP	12/31/22	0000000		KCVM-93.5 THE MIX	210.00		01/10/23
						SECOND HALF OF WINTER RADIO ADS - TRAPP FUNDS			
1110	07/23	AP	11/30/22	0000000		KCVM-93.5 THE MIX	210.00		01/10/23
						HALF OF WINTER RADIO ADVERTISING. TRAPP FUNDS			
						ACCOUNT TOTAL	717.00	.00	717.00
101-4511-414.71-01 OFFICE SUPPLIES / OFFICE SUPPLIES									
1085	07/23	AP	12/28/22	0000000		OFFICE EXPRESS OFFICE PRODUCT	6.08		01/10/23
						COPY PAPER			
1085	07/23	AP	12/01/22	0000000		STOREY KENWORTHY	4.60		01/10/23
						#10 REGULAR ENVELOPES			
						ACCOUNT TOTAL	10.68	.00	10.68

PREPARED 01/10/2023, 11:21:08
 PROGRAM GM360L
 CITY OF CEDAR FALLS

ACCOUNT ACTIVITY LISTING

PAGE 18
 ACCOUNTING PERIOD 06/2023

GROUP NBR	PO NBR	ACCTG PER.	CD	DATE	TRANSACTION NUMBER	DESCRIPTION	DEBITS	CREDITS	CURRENT BALANCE	POST DT
FUND 101 GENERAL FUND										
101-4511-414.72-02						OPERATING SUPPLIES / LAUNDRY				
1097				07/23	AP 12/23/22 0000000	ARAMARK	7.25		01/10/23	
						TOWELS&MATS-STATION #2				
1115				07/23	AP 12/23/22 0000000	ARAMARK	24.60		01/10/23	
						TOWELS,MATS-PSS BUILDING				
1097				07/23	AP 12/09/22 0000000	ARAMARK	7.25		01/10/23	
						TOWELS&MATS-STATION #2				
1115				07/23	AP 12/09/22 0000000	ARAMARK	24.60		01/10/23	
						TOWELS,MATS-PSS BUILDING				
						ACCOUNT TOTAL	63.70	.00	63.70	
101-4511-414.72-07 OPERATING SUPPLIES / EMS/RESCUE SUPPLIES										
1113				07/23	AP 12/20/22 0142132	US BANK	95.40		01/06/23	
						MARSARSWATERRESCUESYSINC				
						5.5 MM REPLACEMENT ROPE				
						ACCOUNT TOTAL	95.40	.00	95.40	
101-4511-414.72-20 OPERATING SUPPLIES / OFFICERS EQUIPMENT										
1097				07/23	AP 12/16/22 0000000	SANDRY FIRE SUPPLY, L.L.C.	994.50		01/10/23	
						GLOBE 14"BOOT,8.5-SCHARNA				
						GLOBE 14"BOOT,SZ 7-LUCK				
1097				07/23	AP 12/09/22 0000000	SANDRY FIRE SUPPLY, L.L.C.	52.50		01/10/23	
						1PR GLOVES SZ 7-RICHTER				
						EXT RESCUE ANTI-DEBRIS				
1097				07/23	AP 12/03/22 0000000	SANDRY FIRE SUPPLY, L.L.C.	100.02		01/10/23	
						NAME PATCH ON COAT-VELCRO				
						PATCH;8 LETTERS-ANDERSEN				
1097				07/23	AP 12/02/22 0000000	SANDRY FIRE SUPPLY, L.L.C.	429.00		01/10/23	
						1PR GLOVES&HOOD-LUCK				
						2PR GLOVES&HOOD-SCHARNAU				
1113				07/23	AP 11/29/22 0142132	US BANK	205.50		01/06/23	
						BADGEANDWALLET.COM				
						RESTOCK - LAPEL PINS				
1113				07/23	AP 11/25/22 0142132	US BANK	47.49		01/06/23	
						AMZN MKTP US*HW9Q314N2 AM				
						GROUND FAULT TESTERS (6)				
1113				07/23	AP 11/22/22 0142132	US BANK	63.42		01/06/23	
						AMAZON.COM*HI5036QU2 AMZN				
						HELMET VISOR-B HEUER				
						ACCOUNT TOTAL	1,892.43	.00	1,892.43	
101-4511-414.72-99 OPERATING SUPPLIES / POSTAGE										
1097				07/23	AP 12/21/22 0000000	FEDERAL EXPRESS	19.15		01/10/23	
						SHIP TO FIRECOM				
						MCNAMARA-HEADSET				
						ACCOUNT TOTAL	19.15	.00	19.15	
101-4511-414.73-02 OTHER SUPPLIES / DORMITORY FURNISHINGS										
1113				07/23	AP 11/28/22 0142132	US BANK	318.49		01/06/23	
						AMAZON.COM*HW6UA4KE0 AMZN				
						NEW BUNN COFFEE POT				
						ACCOUNT TOTAL	318.49	.00	318.49	

PREPARED 01/10/2023, 11:21:08
PROGRAM GM360L
CITY OF CEDAR FALLS

ACCOUNT ACTIVITY LISTING

PAGE 19
ACCOUNTING PERIOD 06/2023

GROUP NBR	PO NBR	ACCTG PER.	CD	DATE	TRANSACTION NUMBER	DESCRIPTION	DEBITS	CREDITS	CURRENT BALANCE	POST DT
FUND 101 GENERAL FUND										
101-4511-414.73-06						OTHER SUPPLIES / BUILDING REPAIR				
1097		07/23 AP		12/09/22	0000000	STETSON BUILDING PRODUCTS LLC	80.27			01/10/23
						MASTERMACO MORTOR/CONCR				
						&TAP HEX-PSS BLDG REPAIR				
						ACCOUNT TOTAL	80.27	.00	80.27	
101-4511-414.73-10 OTHER SUPPLIES / HEADQUARTER SUPPLIES										
1115		07/23 AP		12/16/22	0000000	CITY LAUNDERING CO.	72.97			01/10/23
						RESTOCK FIRST AID KITS				
1094		07/23 AP		11/30/22	0000000	NAPA AUTO PARTS	224.85			01/10/23
						NAPA PARTS				
						ACCOUNT TOTAL	297.82	.00	297.82	
101-4511-414.83-06 TRANSPORTATION&EDUCATION / EDUCATION										
1085		07/23 AP		01/09/23	0000000	MORGAN, JANE	250.00			01/10/23
						REG:CPR INSTR. SCHOOL				
1097		07/23 AP		12/21/22	0000000	FIRE SERVICE TRNG. BUREAU	50.00			01/10/23
						CERT FEE-FIRE INSTR 1				
						MATTHEW KRUEGER				
1097		07/23 AP		12/20/22	0000000	FIRE SERVICE TRNG. BUREAU	50.00			01/10/23
						CERT FEE-FIRE INSTR 1				
						RETAKA - JOAH GETZ				
1097		07/23 AP		12/16/22	0000000	FIRE SERVICE TRNG. BUREAU	50.00			01/10/23
						CERT FEE-FIRE INSTR 1				
						THOMAS BALTES				
1113		07/23 AP		12/12/22	0142132	US BANK		81.32		01/06/23
						AMERICAN HEART SHOPCPR				
						REFUNOED CLASS				
1113		07/23 AP		12/09/22	0142132	US BANK	81.32			01/06/23
						AMERICAN HEART SHOPCPR				
						BLS INSTRUCTOR CLASS				
1113		07/23 AP		12/09/22	0142132	US BANK	76.00			01/06/23
						AMERICAN HEART SHOPCPR				
						CPR INSTRUCTOR SCHOOL (2)				
1097		07/23 AP		12/05/22	0000000	FIRE SERVICE TRNG. BUREAU	50.00			01/10/23
						CERT FEE-FIRE INSTR 1				
						JOSH GETZ				
1113		07/23 AP		12/01/22	0142132	US BANK	1,429.00			01/06/23
						PAYPAL *CMC RESCUE				
						REG:ROPE RESCUE TECH.III				
						ACCOUNT TOTAL	2,036.32	81.32	1,955.00	
101-4511-414.86-01 REPAIR & MAINTENANCE / REPAIR & MAINTENANCE										
1097		07/23 AP		12/01/22	0000000	PROSHIELD FIRE & SECURITY	165.00			01/10/23
						EXT. INSP./RECHARGE				
						1718 MAIN STREET				
						ACCOUNT TOTAL	165.00	.00	165.00	
101-4511-414.89-40 MISCELLANEOUS SERVICES / UNIFORM ALLOWANCE										
1097		07/23 AP		12/14/22	0000000	COVER-ALL EMBROIDERY, INC.	75.00			01/10/23
						EMBROIDER SHIRTS				
1097		07/23 AP		10/31/22	0000000	WERTJES UNIFORMS	119.98			01/10/23

PREPARED 01/10/2023, 11:21:08
 PROGRAM GM360L
 CITY OF CEDAR FALLS

ACCOUNT ACTIVITY LISTING

PAGE 20
 ACCOUNTING PERIOD 06/2023

GROUP NBR	FO NBR	ACCTG PER.	CD	DATE	TRANSACTION NUMBER	DESCRIPTION	DEBITS	CREDITS	CURRENT BALANCE	POST DT
FUND 101 GENERAL FUND										
101-4511-414.89-40						MISCELLANEOUS SERVICES / UNIFORM ALLOWANCE				
						UNIFORM ALLOWANCE-PANTS				
						TODD TAYLOR				
1097				07/23	AP 10/31/22 00000000	WERTJES UNIFORMS	119.98			01/10/23
						UNIFORM ALLOWANCE-PANTS				
						TROY PURDY				
1097				07/23	AP 10/10/22 00000000	WERTJES UNIFORMS	393.47			01/10/23
						UNIFORM ALLOWANCE-NEWHIRE				
						RICHTER;QTRZIP;BOOT,CARGO				
1097				07/23	AP 10/06/22 00000000	WERTJES UNIFORMS	129.00			01/10/23
						UNIFORM ALLOWANCE-SHOES				
						ROCKY; SZ 11.5-Z.ANDERSEN				
						ACCOUNT TOTAL	837.43	.00		837.43
101-4511-414.93-01						EQUIPMENT / EQUIPMENT				
1097				07/23	AP 12/16/22 00000000	SANDRY FIRE SUPPLY, L.L.C.	498.00			01/10/23
						2 GAS METERS FOR 501&502				
						DET ALTAIR,SGLGAS,CO,L25				
1097				07/23	AP 12/12/22 00000000	SANDRY FIRE SUPPLY, L.L.C.	202.03			01/10/23
						SCBA;2022 CYLINDER REPAIR				
						VALVES,BOLTS,NUT,ORING				
						ACCOUNT TOTAL	700.03	.00		700.03
101-5521-415.71-01						OFFICE SUPPLIES / OFFICE SUPPLIES				
1085				07/23	AP 12/28/22 00000000	OFFICE EXPRESS OFFICE PRODUCT	6.08			01/10/23
						COPY PAPER				
1115				07/23	AP 12/27/22 00000000	OFFICE EXPRESS OFFICE PRODUCT	70.10			01/10/23
						PEN REFILLS				
						BERTÉ				
1115				07/23	AP 12/21/22 00000000	OFFICE EXPRESS OFFICE PRODUCT	85.11			01/10/23
						BINDERS;STAB DIVIDERS				
1115				07/23	AP 12/19/22 00000000	OFFICE EXPRESS OFFICE PRODUCT		4.50		01/10/23
						CREDIT MEMO 267918-01				
						PAPER				
1115				07/23	AP 12/14/22 00000000	OFFICE EXPRESS OFFICE PRODUCT	179.80			01/10/23
						PAPER (4 CASES)				
1115				07/23	AP 12/13/22 00000000	STOREY KENWORTHY	1,320.50			01/10/23
						PRINTING-PD OT DUPLICATE				
						FORMS				
1085				07/23	AP 12/01/22 00000000	STOREY KENWORTHY	4.60			01/10/23
						#10 REGULAR ENVELOPES				
1113				07/23	AP 11/30/22 0142132	US BANK	200.00			01/06/23
						ID ZONE				
						INK RIBBONS-POLICE DEPT.				
						ACCOUNT TOTAL	1,866.19	4.50		1,861.69
101-5521-415.72-01						OPERATING SUPPLIES / OPERATING SUPPLIES				
1115				07/23	AP 01/03/23 00000000	RASMUSSEN CO., THE	100.00			01/10/23
						TOW 2022 KIA STINGER				
						#23-000648				
1115				07/23	AP 01/03/23 00000000	RASMUSSEN CO., THE	100.00			01/10/23
						TOW 2005 FORD FOCUS				
						#23-000701				
1115				07/23	AP 01/03/23 00000000	RASMUSSEN CO., THE	100.00			01/10/23
						TOW 2014 GMC ACADIA				
						#23-000630				
1115				07/23	AP 01/03/23 00000000	SHRED-IT USA	54.46			01/10/23

PREPARED 01/10/2023, 11:21:08
 PROGRAM GM360L
 CITY OF CEDAR FALLS

ACCOUNT ACTIVITY LISTING

PAGE 21
 ACCOUNTING PERIOD 06/2023

GROUP NBR	PO NBR	ACCTG PER.	CD	----TRANSACTION---- DATE	NUMBER	DESCRIPTION	DEBITS	CREDITS	CURRENT BALANCE POST DT
FUND 101 GENERAL FUND									
101-5521-415.72-01 OPERATING SUPPLIES / OPERATING SUPPLIES						continued			
1115				07/23 AP 12/24/22	0000000	RASMUSSEN CO., THE	100.00		01/10/23
						ON-SITE DOC. DESTRUCTION			
						TICKET #8151802253 12/22			
1115				07/23 AP 12/23/22	0000000	ARAMARK	18.61		01/10/23
						WINCH CFPD CAR#18			
1115				07/23 AP 12/19/22	0000000	RASMUSSEN CO., THE	100.00		01/10/23
						MATS-PSS BUILDING			
1115				07/23 AP 12/16/22	0000000	CITY LAUNDERING CO.	72.98		01/10/23
						TOW FORD FUSION			
						#22-101389			
1115				07/23 AP 12/09/22	0000000	ARAMARK	18.61		01/10/23
						RESTOCK FIRST AID KITS			
1115				07/23 AP 12/07/22	0000000	CROSS PRECISION MEASUREMENT	190.00		01/10/23
						MATS-PSS BUILDING			
						TEST & CALIBRATE SCALE			
						CRIME LAB			
1115				07/23 AP 12/05/22	0000000	RASMUSSEN CO., THE	100.00		01/10/23
						TOW 2001 CHEV SILVERADO			
						#22-097054			
1113				07/23 AP 12/01/22	0142132	US BANK	132.96		01/06/23
						AMZN MKTP US*9864F65A3			
						2 LITHIUM BATTERY PACKS			
1115				07/23 AP 12/01/22	0000000	PRIMARY SYSTEMS	192.00		01/10/23
						ALARM MONITORING FEE'23			
						1500 BLUFF STREET			
1115				07/23 AP 11/29/22	0000000	RASMUSSEN CO., THE	100.00		01/10/23
						TOW 2005 PONTIAC G6			
						#22-095846			
ACCOUNT TOTAL							1,379.62	.00	1,379.62
101-5521-415.72-20 OPERATING SUPPLIES / OFFICERS EQUIPMENT									
1113				07/23 AP 12/09/22	0142132	US BANK	415.00		01/06/23
						INTOXIMETERS INC			
						NEW ALCO SENSOR FST UNIT			
1113				07/23 AP 12/02/22	0142132	US BANK	79.00		01/06/23
						LASER-LABS.COM			
						ENFORCER II TINT METER			
1115				07/23 AP 10/31/22	0000000	WERTJES UNIFORMS	44.99		01/10/23
						OPT. EQUIP ALLOW.-S.MOORE			
						INNER BELT			
1097				07/23 AP 10/10/22	0000000	WERTJES UNIFORMS	24.00		01/10/23
						OPTIONAL EQUIP.-RICHTER			
						3 BELT KEEPERS			
ACCOUNT TOTAL							562.99	.00	562.99
101-5521-415.72-99 OPERATING SUPPLIES / POSTAGE									
1113				07/23 AP 12/01/22	0142132	US BANK	53.00		01/06/23
						MR. GUNS			
						SHIPPING COSTS			
ACCOUNT TOTAL							53.00	.00	53.00
101-5521-415.81-01 PROFESSIONAL SERVICES / PROFESSIONAL SERVICES									
1115				07/23 AP 01/03/23	0000000	MCKENNA MCNELLY PHOTOGRAPHY	65.00		01/10/23
						PROF.PHOTO- L.BARRON			
1115				07/23 AP 12/15/22	0000000	NET TRANSCRIPTS, INC.	49.75		01/10/23

PREPARED 01/10/2023, 11:21:08
PROGRAM GM360L
CITY OF CEDAR FALLS

ACCOUNT ACTIVITY LISTING

PAGE 22
ACCOUNTING PERIOD 06/2023

GROUP NBR	PO NBR	ACCTG PER.	CD	DATE	TRANSACTION NUMBER	DESCRIPTION	DEBITS	CREDITS	CURRENT BALANCE	POST DT
FUND 101 GENERAL FUND										
101-5521-415.81-01						PROFESSIONAL SERVICES / PROFESSIONAL SERVICES				continued
1115				07/23	AP 12/15/22 00000000	MCKENNA MCNELLY PHOTOGRAPHY	65.00			01/10/23
						TRANSCRIPTION SERVICES CASE 22087860				
1115				07/23	AP 12/15/22 00000000	NET TRANSCRIPTS, INC.	30.00			01/10/23
						PROF.PHOTO- G.CARMAN CASE 22-97054				
1115				07/23	AP 12/15/22 00000000	NET TRANSCRIPTS, INC.	105.47			01/10/23
						TRANSCRIPTION SERVICES CASE 22-97054				
						ACCOUNT TOTAL	315.22	.00	315.22	
101-5521-415.83-04 TRANSPORTATION&EDUCATION / DUES & MEMBERSHIPS										
1085				07/23	AP 01/04/23 00000000	IOWA STATE POLICE ASSOCIATION	2,760.00			01/10/23
						2023 ISPA DUES (69)				
1113				07/23	AP 12/05/22 0142132	US BANK	30.00			01/06/23
						IA SECRETARY OF STATE RENEW NOTARY-T FEY				
						ACCOUNT TOTAL	2,790.00	.00	2,790.00	
101-5521-415.83-05 TRANSPORTATION&EDUCATION / TRAVEL (FOOD/MILEAGE/LOD)										
1113				07/23	AP 12/19/22 0142132	US BANK	35.16			01/06/23
						BREAKFAST CLUB WDM MEAL: SURVIVAL TACTICS				
1113				07/23	AP 12/19/22 0142132	US BANK	32.93			01/06/23
						BREAKFAST CLUB WDM MEAL: SURVIVAL TACTICS				
1113				07/23	AP 12/19/22 0142132	US BANK	51.51			01/06/23
						GRUMPY GOAT TAVERN-MILLS MEAL: SURVIVAL TACTICS				
1113				07/23	AP 12/19/22 0142132	US BANK	28.02			01/06/23
						FUZZYS TACO SHOP - ANKENY MEAL: SURVIVAL TACTICS				
1113				07/23	AP 12/19/22 0142132	US BANK	19.80			01/06/23
						KUM&GO 0131 HUXLEY FUEL: SURVIVAL TACTICS				
1113				07/23	AP 12/19/22 0142132	US BANK	621.60			01/06/23
						HILTON GARDEN INN WEST DE HOTEL: SURVIVAL TACTICS				
1113				07/23	AP 12/19/22 0142132	US BANK	621.60			01/06/23
						HILTON GARDEN INN WEST DE HOTEL: SURVIVAL TACTICS				
1113				07/23	AP 12/16/22 0142132	US BANK	36.00			01/06/23
						BREAKFAST CLUB WDM MEAL: SURVIVAL TACTICS				
1113				07/23	AP 12/16/22 0142132	US BANK	39.78			01/06/23
						EL FOGONCITO MEAL: SURVIVAL TACTICS				
1113				07/23	AP 12/16/22 0142132	US BANK	124.32			01/06/23
						AIRPORT HOLIDAY INN - DE HOTEL: FTO TRNG TACTICS				
1113				07/23	AP 12/15/22 0142132	US BANK	22.00			01/06/23
						GREAT AMERICAN GRILLE MEAL: SURVIVAL TACTICS				
1113				07/23	AP 12/15/22 0142132	US BANK	49.00			01/06/23
						CHEESECAKE DES MOINE MEAL: SURVIVAL TACTICS				
1113				07/23	AP 12/14/22 0142132	US BANK	22.00			01/06/23
						GREAT AMERICAN GRILLE MEAL: SURVIVAL TACTICS				
1113				07/23	AP 12/13/22 0142132	US BANK	57.52			01/06/23
						TST* BARN TOWN BREWING MEAL: SURVIVAL TACTICS				

PREPARED 01/10/2023, 11:21:08
 PROGRAM GM360L
 CITY OF CEDAR FALLS

ACCOUNT ACTIVITY LISTING

PAGE 23
 ACCOUNTING PERIOD 06/2023

GROUP	PO	ACCTG	----TRANSACTION----		DESCRIPTION	DEBITS	CREDITS	CURRENT	POST DT
NBR	NBR	PER.	CD	DATE	NUMBER			BALANCE	
FUND 101 GENERAL FUND									
101-5521-415.83-05					TRANSPORTATION&EDUCATION / TRAVEL (FOOD/MILEAGE/LOD)				continued
1113				07/23	AP 12/13/22 0142132	US BANK	41.13		01/06/23
					TARGET 00019018	LUNCHES:SURVIVAL TACTICS			
1113				07/23	AP 12/05/22 0142132	US BANK	79.16		01/06/23
					QUINTONS DELI AND BAR	MEALS:EXECUTIVE LEADERSHP			
1113				07/23	AP 12/02/22 0142132	US BANK	67.97		01/06/23
					ROCK BAR AMERICAN GRIL	MEALS:EXECUTIVE LEADERSHP			
1113				07/23	AP 12/01/22 0142132	US BANK	74.11		01/06/23
					TST* LUCKYS ON 16TH	MEALS:EXECUTIVE LEADERSHP			
1113				07/23	AP 11/29/22 0142132	US BANK	69.33		01/06/23
					TORNADOS GRUB&PUB	MEALS:EXECUTIVE LEADERSHP			
					ACCOUNT TOTAL		2,092.94	.00	2,092.94
101-5521-415.83-06 TRANSPORTATION&EDUCATION / EDUCATION									
1115				07/23	AP 12/08/22 0000000	IOWA LAW ENFORCEMENT ACADEMY	625.00		01/10/23
					FIREARMS INSTR SCHOOL	BALTES; 11/28 - 12/2			
1113				07/23	AP 11/30/22 0142132	US BANK	680.40		01/06/23
					AED.US_CORO MEDICAL	LIFEPAK CR2 AED TRAINER			
					ACCOUNT TOTAL		1,305.40	.00	1,305.40
101-5521-415.86-06 REPAIR & MAINTENANCE / WEAPONS MAINTENANCE									
1115				07/23	AP 12/07/22 0000000	BROWNELLS, INC.	97.97		01/10/23
					RIFLE ACCESSORIES	AR15 SAFETY SELECTOR(3)			
1115				07/23	AP 11/29/22 0000000	BROWNELLS, INC.	23.49		01/10/23
					RIFLE ACCESSORIES	AR-15 FRONT SIGHT(2)			
					ACCOUNT TOTAL		121.46	.00	121.46
101-5521-415.89-40 MISCELLANEOUS SERVICES / UNIFORM ALLOWANCE									
1115				07/23	AP 10/31/22 0000000	WERTJES UNIFORMS	62.00		01/10/23
					UNIFORM ALLOWANCE-S.MOORE	PANTS			
1115				07/23	AP 10/31/22 0000000	WERTJES UNIFORMS	55.99		01/10/23
					UNIFORM ALLOWANCE-JANIKOW	LS POLO PATCHES/EMBROID			
1115				07/23	AP 10/31/22 0000000	WERTJES UNIFORMS	108.00		01/10/23
					UNIFORM ALLOWANCE-MARTINE	LS POLOS(2)/PATCHES/NAME			
1115				07/23	AP 10/25/22 0000000	WERTJES UNIFORMS	54.00		01/10/23
					UNIFORM ALLOWANCE-HAISLET	LS SHIRT/3 PATCHES			
1115				07/23	AP 10/22/22 0000000	WERTJES UNIFORMS	174.00		01/10/23
					UNIFORM ALLOWANCE-LUCK	PANTS(2)			
1115				07/23	AP 10/18/22 0000000	WERTJES UNIFORMS	39.99		01/10/23
					UNIFORM ALLOWANCE-LUCK	GLOVES			
1115				07/23	AP 10/17/22 0000000	WERTJES UNIFORMS	39.99		01/10/23
					UNIFORM ALLOWANCE-DANILSO	GLOVES			
1115				07/23	AP 10/17/22 0000000	WERTJES UNIFORMS	15.95		01/10/23
					UNIFORM ALLOWANCE-GERZEMA	LT PATCHES			

PREPARED 01/10/2023, 11:21:08
 PROGRAM GM360L
 CITY OF CEDAR FALLS

ACCOUNT ACTIVITY LISTING

PAGE 24
 ACCOUNTING PERIOD 06/2023

GROUP NBR	PO NBR	ACCTG PER.	CD	DATE	-----TRANSACTION----- NUMBER	DESCRIPTION	DEBITS	CREDITS	CURRENT BALANCE	POST DT
FUND 101 GENERAL FUND										
101-5521-415.89-40 MISCELLANEOUS SERVICES / UNIFORM ALLOWANCE						continued				
1115		07/23	AP	10/10/22	0000000	WERTJES UNIFORMS	985.68			01/10/23
						UNIFORM ALLOWANCE-RICHTER NEW HIRE				
1115		07/23	AP	10/05/22	0000000	WERTJES UNIFORMS	191.40			01/10/23
						UNIFORM ALLOWANCE-PUTNEY PANTS				
1115		07/23	AP	10/05/22	0000000	WERTJES UNIFORMS	119.99			01/10/23
						UNIFORM ALLOWANCE-HOEFT ATAC BOOTS				
						ACCOUNT TOTAL	1,846.99	.00	1,846.99	
101-6613-433.72-01 OPERATING SUPPLIES / OPERATING SUPPLIES										
1085		07/23	AP	01/03/23	0000000	THOMPSON SHOES	175.00			01/10/23
						SAFETY SHOES-L CLEMENTS P.O. 56804				
1094		07/23	AP	11/30/22	0000000	NAPA AUTO PARTS	296.58			01/10/23
						NAPA PARTS				
						ACCOUNT TOTAL	471.58	.00	471.58	
101-6613-433.86-01 REPAIR & MAINTENANCE / REPAIR & MAINTENANCE										
1084		07/23	AP	12/21/22	0000000	MENARDS-CEDAR FALLS	54.34			01/10/23
						CEMETERY OFFICE BASE				
1052		07/23	AP	12/14/22	0000000	MENARDS-CEDAR FALLS	6.53			01/10/23
						CEMETERY				
						ACCOUNT TOTAL	60.87	.00	60.87	
101-6616-446.72-01 OPERATING SUPPLIES / OPERATING SUPPLIES										
1084		07/23	AP	12/28/22	0000000	BUILDERS SELECT LLC	36.99			01/10/23
						BUILDER BOARD				
						PROJECT#: 062501				
1094		07/23	AP	12/21/22	0000000	OFFICE EXPRESS OFFICE PRODUCT	619.13			01/10/23
						LINERS, TISSUE, TOWELS AND SOAP				
						PROJECT#: 062511				
1052		07/23	AP	12/19/22	0000000	OFFICE EXPRESS OFFICE PRODUCT	21.15			01/10/23
						FLOOR CLEANER				
						PROJECT#: 062506				
1113		07/23	AP	12/19/22	0142132	US BANK	8.94			01/06/23
						AMZN MKTP US*L40EU7JC3 DOOR CARD HOLDERS				
						PROJECT#: 062506				
1052		07/23	AP	12/16/22	0000000	OFFICE EXPRESS OFFICE PRODUCT	170.42			01/10/23
						DRY ERASE BOARD				
						PROJECT#: 062506				
1052		07/23	AP	12/15/22	0000000	ECHO GROUP, INC.	776.70			01/10/23
						LIGHT BULBS				
						PROJECT#: 062505				
1052		07/23	AP	12/14/22	0000000	ECHO GROUP, INC.		88.90		01/10/23
						RETURN BULBS				

PREPARED 01/10/2023, 11:21:08
 PROGRAM GM360L
 CITY OF CEDAR FALLS

ACCOUNT ACTIVITY LISTING

PAGE 25
 ACCOUNTING PERIOD 06/2023

GROUP NBR	PO NBR	ACCTG PER.	CD	DATE	TRANSACTION NUMBER	DESCRIPTION	DEBITS	CREDITS	CURRENT BALANCE	POST DT
FUND 101 GENERAL FUND										
101-6616-446.72-01 OPERATING SUPPLIES / OPERATING SUPPLIES						continued				
PROJECT#: 062510										
1094		07/23 AP		12/14/22	0000000	PLUMB SUPPLY COMPANY, LLC	101.39			01/10/23
PROJECT#: 062501										
1113		07/23 AP		12/14/22	0142132	US BANK	66.40			01/06/23
AMAZON.COM*0N8068QQ3 CLOSED SIGNS										
PROJECT#: 062501										
1113		07/23 AP		12/14/22	0142132	US BANK	20.47			01/06/23
AMZN MKTP US*0H79E8HR3 WOOD CLEANER										
PROJECT#: 062501										
1052		07/23 AP		12/13/22	0000000	OFFICE EXPRESS OFFICE PRODUCT	264.28			01/10/23
CLEANER, DISINFECTANT, FRESHNER, LINERS										
PROJECT#: 062506										
1113		07/23 AP		12/13/22	0142132	US BANK	12.35			01/06/23
AMZN MKTP US*VE0AW3V03 BATTERIES										
PROJECT#: 062507										
1113		07/23 AP		12/05/22	0142132	US BANK	135.84			01/06/23
AMZN MKTP US*4T05D3ZH3 AM DRUM PUMP AND VAC BAGS										
1094		07/23 AP		11/30/22	0000000	NAPA AUTO PARTS	964.94			01/10/23
NAPA PARTS										
1113		07/23 AP		11/25/22	0142132	US BANK	110.40			01/06/23
SP KRUEGER POTTERY CLAY TRAPS										
PROJECT#: 062505										
1113		07/23 AP		11/25/22	0142132	US BANK	5.74			01/06/23
AMZN MKTP US*HI5QP4R52 VACUUM BELT										
PROJECT#: 062508										
1113		07/23 AP		11/25/22	0142132	US BANK	26.99			01/06/23
AMZN MKTP US*HW6B63M00 PUMICE SCOURING PADS										
PROJECT#: 062506										
ACCOUNT TOTAL							3,342.13	88.90	3,253.23	
101-6616-446.73-05 OTHER SUPPLIES / OPERATING EQUIPMENT										
1084		07/23 AP		10/07/22	0000000	CAMPBELL SUPPLY WATERLOO	552.94			01/10/23
TOOL BOX AND BATTERY CHARGER										
PROJECT#: 062506										
ACCOUNT TOTAL							552.94	.00	552.94	
101-6616-446.73-06 OTHER SUPPLIES / BUILDING REPAIR										
1113		07/23 AP		12/19/22	0142132	US BANK	8.99			01/06/23
AMZN MKTP US*OF50F2ZF3 FAN SWITCH										
PROJECT#: 062506										
1084		07/23 AP		12/15/22	0000000	MENARDS-CEDAR FALLS	105.47			01/10/23
SHOWER VALVE FITTING AND CLEANER										
PROJECT#: 062510										
1094		07/23 AP		12/14/22	0000000	PLUMB SUPPLY COMPANY, LLC	19.15			01/10/23

PREPARED 01/10/2023, 11:21:08
 PROGRAM GM360L
 CITY OF CEDAR FALLS

ACCOUNT ACTIVITY LISTING

PAGE 26
 ACCOUNTING PERIOD 06/2023

GROUP NBR	PO NBR	ACCTG PER.	CD	---TRANSACTION--- DATE	NUMBER	DESCRIPTION	DEBITS	CREDITS	CURRENT BALANCE POST DT
FUND 101 GENERAL FUND									
101-6616-446.73-06 OTHER SUPPLIES / BUILDING REPAIR						continued			
VAC BREAKER AND PLUMBING REPAIR									
PROJECT#:		062501							
1052		07/23 AP 12/07/22		0000000		FERGUSON ENTERPRISES, INC.	19.98		01/10/23
TOILET TANK GASKETS									
PROJECT#:		062501							
1052		07/23 AP 12/06/22		0000000		AIRE SERV.OF THE CEDAR VALLEY	220.00		01/10/23
HVAC REPAIRS									
PROJECT#:		062506							
ACCOUNT TOTAL							373.59	.00	373.59
101-6616-446.86-02 REPAIR & MAINTENANCE / BUILDINGS & GROUNDS									
1084		07/23 AP 12/23/23		0000000		ARAMARK	19.50		01/10/23
MAT SERVICE									
PROJECT#:		062501							
1084		07/23 AP 12/23/22		0000000		ARAMARK	52.35		01/10/23
MAT SERVICE									
PROJECT#:		062506							
1094		07/23 AP 12/19/22		0000000		CHRISTIE DOOR COMPANY	4,428.00		01/10/23
DOOR PANEL REPLACEMENT									
ACCOUNT TOTAL							4,499.85	.00	4,499.85
101-6616-446.86-14 REPAIR & MAINTENANCE / MECH EQUIPMENT SERVICING									
1094		07/23 AP 12/15/22		0000000		WILSON RESTAURANT SUPPLY, INC	4,248.59		01/10/23
ICE MACHINE									
PROJECT#:		062506							
ACCOUNT TOTAL							4,248.59	.00	4,248.59
101-6616-446.93-01 EQUIPMENT / EQUIPMENT									
1052		07/23 AP 12/09/22		0000000		VAN METER, INC.	7,181.46		01/10/23
LED LIGHTS FOR VECH STOR GARAGE									
PROJECT#:		062506							
ACCOUNT TOTAL							7,181.46	.00	7,181.46
101-6625-432.71-01 OFFICE SUPPLIES / OFFICE SUPPLIES									
1042		07/23 AP 12/29/22		0000000		OFFICE EXPRESS OFFICE PRODUCT	1.57		01/10/23
MASKING TAPE									
1042		07/23 AP 12/28/22		0000000		OFFICE EXPRESS OFFICE PRODUCT	4.92		01/10/23
TAPE,PUTTY									
1042		07/23 AP 12/20/22		0000000		OFFICE EXPRESS OFFICE PRODUCT	6.17		01/10/23
ENVELOPES, GLUE STICKS									
1042		07/23 AP 12/19/22		0000000		OFFICE EXPRESS OFFICE PRODUCT	4.36		01/10/23

PREPARED 01/10/2023, 11:21:08
 PROGRAM GM360L
 CITY OF CEDAR FALLS

ACCOUNT ACTIVITY LISTING

PAGE 27
 ACCOUNTING PERIOD 06/2023

GROUP NBR	PO NBR	ACCTG PER.	CD	---TRANSACTION--- DATE	NUMBER	DESCRIPTION	DEBITS	CREDITS	CURRENT BALANCE POST DT
FUND 101 GENERAL FUND									
101-6625-432.71-01 OFFICE SUPPLIES / OFFICE SUPPLIES						continued			
1042				07/23 AP 12/19/22	0000000	OFFICE EXPRESS OFFICE PRODUCT	22.48		01/10/23
						LEGAL PAPER			
1085				07/23 AP 12/01/22	0000000	STOREY KENWORTHY	46.00		01/10/23
						COPY PAPER			
						#10 REGULAR ENVELOPES			
ACCOUNT TOTAL							85.50	.00	85.50
101-6625-432.72-01 OPERATING SUPPLIES / OPERATING SUPPLIES									
1042				07/23 AP 12/19/22	0000000	OFFICE EXPRESS OFFICE PRODUCT	.86		01/10/23
						PENS			
ACCOUNT TOTAL							.86	.00	.86
101-6625-432.81-44 PROFESSIONAL SERVICES / USGS RIVER GAUGE									
1042				07/23 AP 12/20/22	0000000	MIDAMERICAN ENERGY	10.18		01/10/23
						FINCHFORD RIVER GAGUE			
						11/18-12/20/22			
ACCOUNT TOTAL							10.18	.00	10.18
101-6633-423.72-01 OPERATING SUPPLIES / OPERATING SUPPLIES									
1085				07/23 AP 01/03/23	0000000	THOMPSON SHOES	170.00		01/10/23
						SAFETY SHOES-B CONRAD			
						P.O. 56803			
1085				07/23 AP 12/31/22	0000000	BROWN'S SHOE FIT	120.00		01/10/23
						SAFETY SHOES-K CROSS			
						P.O. 56806			
1085				07/23 AP 12/31/22	0000000	BROWN'S SHOE FIT	114.95		01/10/23
						SAFETY SHOES-G MILLER			
						P.O. 56802			
1052				07/23 AP 12/21/22	0000000	O'DONNELL ACE HARDWARE	64.87		01/10/23
						PAINT HARDNER			
1084				07/23 AP 12/16/22	0000000	CITY LAUNDERING CO.	12.12		01/10/23
						FIRST AID SUPPLIES			
1052				07/23 AP 12/13/22	0000000	MENARDS-CEDAR FALLS	7.02		01/10/23
						HARDWARE FOR CHANGING			
						STATION			
1052				07/23 AP 12/02/22	0000000	NORTH AMERICAN SAFETY, INC	57.50		01/10/23
						HI VISION FOR PARKS			
1094				07/23 AP 11/30/22	0000000	NAPA AUTO PARTS	243.54		01/10/23
						NAPA PARTS			
ACCOUNT TOTAL							790.00	.00	790.00
FUND TOTAL							193,433.56	235.65	193,197.91

PREPARED 01/10/2023, 11:21:08
 PROGRAM GM360L
 CITY OF CEDAR FALLS

ACCOUNT ACTIVITY LISTING

PAGE 28
 ACCOUNTING PERIOD 06/2023

GROUP NBR	PO NBR	ACCTG PER.	CD	DATE	-----TRANSACTION----- NUMBER	DESCRIPTION	DEBITS	CREDITS	CURRENT BALANCE	POST DT
FUND 203 TAX INCREMENT FINANCING										
FUND 206 STREET CONSTRUCTION FUND										
206-6637-436.72-17 OPERATING SUPPLIES / UNIFORMS										
1052		07/23	AP	12/02/22	0000000	NORTH AMERICAN SAFETY, INC	98.00			01/10/23
						HI VISION FOR STREETS				
						ACCOUNT TOTAL	98.00	.00	98.00	
206-6637-436.72-54 OPERATING SUPPLIES / BUILDING SUPPLIES										
1052		07/23	AP	12/21/22	0000000	O'DONNELL ACE HARDWARE	6.99			01/10/23
						FUSE				
1094		07/23	AP	12/15/22	0000000	POLK'S LOCK SERVICE, INC.	70.00			01/10/23
						PAD LOCKS AND KEYS				
						ACCOUNT TOTAL	76.99	.00	76.99	
206-6637-436.72-57 OPERATING SUPPLIES / ICE CONTROL										
1094		07/23	AP	12/28/22	0000000	O'DONNELL ACE HARDWARE	1.11			01/10/23
						SCREWS AND BOLTS FOR MAIL				
						BOXES				
1084		07/23	AP	12/19/22	0000000	KRIS ENGINEERING, INC	2,330.40			01/10/23
						JOMA CURB BLOCKS				
1052		07/23	AP	12/16/22	0000000	MENARDS-CEDAR FALLS	19.96			01/10/23
						MAILBOX POST				
1052		07/23	AP	12/14/22	0000000	MENARDS-CEDAR FALLS	71.84			01/10/23
						LATHE FOR SNOW FENCE				
						ACCOUNT TOTAL	2,423.31	.00	2,423.31	
206-6637-436.72-60 OPERATING SUPPLIES / SAFETY SUPPLIES										
1085		07/23	AP	01/03/23	0000000	THOMPSON SHOES	161.50			01/10/23
						SAFETY SHOES-C YOKEM				
						P.O. 56789				
1085		07/23	AP	01/03/23	0000000	THOMPSON SHOES	175.00			01/10/23
						SAFETY SHOES-C PAINE				
						P.O. 56808				
1084		07/23	AP	12/16/22	0000000	CITY LAUNDERING CO.	24.24			01/10/23
						FIRST AID SUPPLIES				
						ACCOUNT TOTAL	360.74	.00	360.74	
206-6637-436.73-06 OTHER SUPPLIES / BUILDING REPAIR										
1084		07/23	AP	12/21/22	0000000	MENARDS-CEDAR FALLS	24.29			01/10/23
						HEAT TAPE				
1052		07/23	AP	12/16/22	0000000	MENARDS-CEDAR FALLS	29.98			01/10/23
						HEAT TAPE FOR BRINE BLDG				
1052		07/23	AP	12/12/22	0000000	MENARDS-CEDAR FALLS	54.89			01/10/23
						BRINE BUILDING CAR PIPES				
						ACCOUNT TOTAL	109.16	.00	109.16	

PREPARED 01/10/2023, 11:21:08
 PROGRAM GM360L
 CITY OF CEDAR FALLS

ACCOUNT ACTIVITY LISTING

PAGE 29
 ACCOUNTING PERIOD 06/2023

GROUP NBR	PO NBR	ACCTG PER.	CD	DATE	TRANSACTION NUMBER	DESCRIPTION	DEBITS	CREDITS	CURRENT BALANCE	POST DT
FUND 206 STREET CONSTRUCTION FUND										
206-6637-436.73-32 OTHER SUPPLIES / STREETS										
1084		07/23 AP		11/30/22	0000000	BMC AGGREGATES L.C. ROADSTONE	475.88			01/10/23
1094		07/23 AP		11/30/22	0000000	NAPA AUTO PARTS NAPA PARTS	108.08			01/10/23
ACCOUNT TOTAL							583.96	.00	583.96	
206-6637-436.83-06 TRANSPORTATION&EDUCATION / EDUCATION										
1113		07/23 AP		12/14/22	0142132	US BANK ISU EVENT REGISTRATION	75.00			01/06/23
ACCOUNT TOTAL							75.00	.00	75.00	
206-6637-436.92-81 STRUCTURE IMPROV & BLDGS / PERMEABLE ALLEY PROGRAM										
1042		07/23 AP		12/07/22	0000000	AECOM TECHNICAL SERVICES, INC 3298-2023 ALLEY RECON	732.34			01/10/23
PROJECT#: 023298										
ACCOUNT TOTAL							732.34	.00	732.34	
206-6647-436.72-01 OPERATING SUPPLIES / OPERATING SUPPLIES										
1052		07/23 AP		12/14/22	0000000	ECHO GROUP, INC. ELECTRICAL SUPPLIES	198.92			01/10/23
1052		07/23 AP		12/14/22	0000000	O'DONNELL ACE HARDWARE HARDWARE	10.26			01/10/23
1052		07/23 AP		12/12/22	0000000	ECHO GROUP, INC. FUSES	603.80			01/10/23
1052		07/23 AP		12/06/22	0000000	LAWSON PRODUCTS, INC. HARDWARE	305.45			01/10/23
1052		07/23 AP		12/05/22	0000000	MENARDS-CEDAR FALLS LIGHT BULBS	59.96			01/10/23
ACCOUNT TOTAL							1,178.39	.00	1,178.39	
206-6647-436.72-60 OPERATING SUPPLIES / SAFETY SUPPLIES										
1084		07/23 AP		12/16/22	0000000	CITY LAUNDERING CO. FIRST AID SUPPLIES	11.78			01/10/23
ACCOUNT TOTAL							11.78	.00	11.78	
206-6647-436.73-12 OTHER SUPPLIES / TRAFFIC SIGNALS										
1052		07/23 AP		12/15/22	0000000	TAPCO BATTERIES FOR FLASHING	749.68			01/10/23
ACCOUNT TOTAL							749.68	.00	749.68	

PREPARED 01/10/2023, 11:21:08
 PROGRAM GM360L
 CITY OF CEDAR FALLS

ACCOUNT ACTIVITY LISTING

PAGE 30
 ACCOUNTING PERIOD 06/2023

GROUP NBR	PO NBR	ACCTG PER.	CD	DATE	TRANSACTION NUMBER	DESCRIPTION	DEBITS	CREDITS	CURRENT BALANCE	POST DT
FUND 206 STREET CONSTRUCTION FUND										
206-6647-436.73-20 OTHER SUPPLIES / POSTS										
1052		07/23	AP	12/19/22	0000000	XCESSORIES SQUARED DEV.& MFG. SIGN POSTS	7,888.00			01/10/23
ACCOUNT TOTAL							7,888.00	.00	7,888.00	
FUND TOTAL							14,287.35	.00	14,287.35	
FUND 215 HOSPITAL FUND										
FUND 216 POLICE BLOCK GRANT FUND										
FUND 217 SECTION 8 HOUSING FUND										
217-2214-432.71-01 OFFICE SUPPLIES / OFFICE SUPPLIES										
1042		07/23	AP	12/29/22	0000000	OFFICE EXPRESS OFFICE PRODUCT	.23			01/10/23
1042		07/23	AP	12/28/22	0000000	OFFICE EXPRESS OFFICE PRODUCT MASKING TAPE	.72			01/10/23
1042		07/23	AP	12/20/22	0000000	OFFICE EXPRESS OFFICE PRODUCT TAPE,PUTTY	.91			01/10/23
1042		07/23	AP	12/19/22	0000000	OFFICE EXPRESS OFFICE PRODUCT ENVELOPES, GLUE STICKS	.70			01/10/23
1042		07/23	AP	12/19/22	0000000	OFFICE EXPRESS OFFICE PRODUCT LEGAL PAPER	3.60			01/10/23
1042		07/23	AP	12/19/22	0000000	OFFICE EXPRESS OFFICE PRODUCT COPY PAPER	.13			01/10/23
1042		07/23	AP	12/19/22	0000000	OFFICE EXPRESS OFFICE PRODUCT PENS				
ACCOUNT TOTAL							6.29	.00	6.29	
217-2214-432.72-01 OPERATING SUPPLIES / OPERATING SUPPLIES										
1085		07/23	AP	12/01/22	0000000	STOREY KENWORTHY #10 REGULAR ENVELOPES	2.30			01/10/23
ACCOUNT TOTAL							2.30	.00	2.30	
FUND TOTAL							8.59	.00	8.59	
FUND 223 COMMUNITY BLOCK GRANT										
223-2224-432.71-01 OFFICE SUPPLIES / OFFICE SUPPLIES										
1042		07/23	AP	12/29/22	0000000	OFFICE EXPRESS OFFICE PRODUCT	.05			01/10/23
1042		07/23	AP	12/28/22	0000000	OFFICE EXPRESS OFFICE PRODUCT MASKING TAPE	.14			01/10/23
1085		07/23	AP	12/28/22	0000000	OFFICE EXPRESS OFFICE PRODUCT TAPE,PUTTY	3.04			01/10/23
1042		07/23	AP	12/20/22	0000000	OFFICE EXPRESS OFFICE PRODUCT COPY PAPER	.18			01/10/23
1042		07/23	AP	12/20/22	0000000	OFFICE EXPRESS OFFICE PRODUCT ENVELOPES, GLUE STICKS				

PREPARED 01/10/2023, 11:21:08
 PROGRAM GM360L
 CITY OF CEDAR FALLS

ACCOUNT ACTIVITY LISTING

PAGE 31
 ACCOUNTING PERIOD 06/2023

GROUP NBR	PO NBR	ACCTG PER.	CD	TRANSACTION DATE	NUMBER	DESCRIPTION	DEBITS	CREDITS	CURRENT BALANCE	POST DT
FUND 223 COMMUNITY BLOCK GRANT										
223-2224-432.71-01 OFFICE SUPPLIES / OFFICE SUPPLIES						continued				
1042		07/23	AP	12/19/22	0000000	OFFICE EXPRESS OFFICE PRODUCT	.17			01/10/23
						LEGAL PAPER				
1042		07/23	AP	12/19/22	0000000	OFFICE EXPRESS OFFICE PRODUCT	.90			01/10/23
						COPY PAPER				
1042		07/23	AP	12/19/22	0000000	OFFICE EXPRESS OFFICE PRODUCT	.03			01/10/23
						PENS				
						ACCOUNT TOTAL	4.51	.00	4.51	
223-2224-432.72-19 OPERATING SUPPLIES / PRINTING										
1085		07/23	AP	12/01/22	0000000	STOREY KENWORTHY	2.30			01/10/23
						#10 REGULAR ENVELOPES				
						ACCOUNT TOTAL	2.30	.00	2.30	
						FUND TOTAL	6.81	.00	6.81	
FUND 224 TRUST & AGENCY										
FUND 242 STREET REPAIR FUND										
242-1240-431.92-25 STRUCTURE IMPROV & BLDGS / CEDAR HEIGHTS AREA RECON										
1042		07/23	AP	12/13/22	0000000	AECOM TECHNICAL SERVICES, INC	22,688.57			01/10/23
						3271-N CEDAR HEIGHTS PH1				11/19-12/09/22
						PROJECT#: 023271				
1042		07/23	AP	12/07/22	0000000	AECOM TECHNICAL SERVICES, INC	858.22			01/10/23
						3271-N CEDAR HEIGHTS PH1				11/5-12/2/22 SURVEY
						PROJECT#: 023271				
						ACCOUNT TOTAL	23,546.79	.00	23,546.79	
242-1240-431.92-44 STRUCTURE IMPROV & BLDGS / STREET RECONSTRUCTION										
1096		07/23	AP	12/30/22	0000000	PETERSON CONTRACTORS	14,157.48			01/10/23
						3230-2022 STREET CONST.				
						PROJECT#: 023230				
1042		07/23	AP	12/07/22	0000000	AECOM TECHNICAL SERVICES, INC	1,784.18			01/10/23
						3299-2023 STREET RECON				11/5-12/2/22 SURVEY
						PROJECT#: 023299				
						ACCOUNT TOTAL	15,941.66	.00	15,941.66	
242-1240-431.98-45 CAPITAL PROJECTS / MAIN STREET RECONSTRUCT										
1042		07/23	AP	12/22/22	0000000	FOTH INFRASTRUCTURE & ENVIRON	40,999.51			01/10/23
						3283-MAIN ST RECONSTRUCT				THROUGH 11/30/22
						PROJECT#: 023283				
						ACCOUNT TOTAL	40,999.51	.00	40,999.51	

PREPARED 01/10/2023, 11:21:08
 PROGRAM GM360L
 CITY OF CEDAR FALLS

ACCOUNT ACTIVITY LISTING

PAGE 32
 ACCOUNTING PERIOD 06/2023

GROUP NBR	PO NBR	ACCTG PER.	CD	TRANSACTION DATE	DESCRIPTION NUMBER	DEBITS	CREDITS	CURRENT BALANCE	POST DT
FUND 242 STREET REPAIR FUND									
					FUND TOTAL	80,487.96	.00	80,487.96	
FUND 254 CABLE TV FUND									
254-1088-431.72-01					OPERATING SUPPLIES / OPERATING SUPPLIES				
1042		07/23	AP	12/19/22	0000000 OFFICE EXPRESS OFFICE PRODUCT	.70			01/10/23
					LEGAL PAPER				
1042		07/23	AP	12/19/22	0000000 OFFICE EXPRESS OFFICE PRODUCT	3.60			01/10/23
					COPY PAPER				
1113		07/23	AP	12/19/22	0142132 US BANK	52.07			01/06/23
					AMZN MKTP US*SU1VD5KJ3 HDMI CABLE ADAPTER,USB C				
1113		07/23	AP	12/07/22	0142132 US BANK	253.10			01/06/23
					AMZN MKTP US*R69OC42N3 AM EXEC. CHAIR/PEN LIGHTS				
1113		07/23	AP	12/05/22	0142132 US BANK	249.99			01/06/23
					AMAZON.COM*XN5VK3EG3 SHARK VACUUM				
1113		07/23	AP	12/05/22	0142132 US BANK	31.96			01/06/23
					AMZN MKTP US*RTONG8DD3 USB FEMALE:MALE ADAPTERS				
1085		07/23	AP	12/01/22	0000000 STOREY KENWORTHY	2.30			01/10/23
					#10 REGULAR ENVELOPES				
					ACCOUNT TOTAL	593.72	.00	593.72	
254-1088-431.72-11 OPERATING SUPPLIES / DUES, BOOKS, MAGAZINES									
1113		07/23	AP	12/05/22	0142132 US BANK	2,039.40			01/06/23
					ADOBE CREATIVE CLOUD ADOBE CREATIVE CLOUD				
1113		07/23	AP	12/01/22	0142132 US BANK	9.99			01/06/23
					ROKFIN ROKFIN MONTHLY SUBSCRIPT.				
					ACCOUNT TOTAL	2,049.39	.00	2,049.39	
254-1088-431.83-05 TRANSPORTATION&EDUCATION / TRAVEL (FOOD/MILEAGE/LOD)									
1113		07/23	AP	12/15/22	0142132 US BANK	58.16			01/06/23
					CASEYS PIZZA 2879 CREW PIZZA DOUBLE HEADER				
1113		07/23	AP	12/02/22	0142132 US BANK	76.66			01/06/23
					GODFATHERS PIZZA GODFATHER'S PIZZA				
1113		07/23	AP	11/28/22	0142132 US BANK	71.00			01/06/23
					TST* URBAN PIE- HOLIDAY HOOPLA CREW MEAL				
					ACCOUNT TOTAL	205.82	.00	205.82	
254-1088-431.93-01 EQUIPMENT / EQUIPMENT									
1113		07/23	AP	12/12/22	0142132 US BANK	1,338.12			01/06/23
					B&H PHOTO 800-606-6969 DIGITAL FORECAST BRIDGE				
1113		07/23	AP	12/09/22	0142132 US BANK	73.29			01/06/23
					B&H PHOTO 800-606-6969 WHIRLWIND SPLIT 6				
1113		07/23	AP	12/01/22	0142132 US BANK	644.56			01/06/23
					B&H PHOTO 800-606-6969 STB EXTERNAL HARD DRIVE				

PREPARED 01/10/2023, 11:21:08
 PROGRAM GM360L
 CITY OF CEDAR FALLS

ACCOUNT ACTIVITY LISTING

PAGE 33
 ACCOUNTING PERIOD 06/2023

GROUP NBR	PO NBR	ACCTG PER.	CD	---TRANSACTION--- DATE	NUMBER	DESCRIPTION	DEBITS	CREDITS	CURRENT BALANCE POST DT
FUND 254 CABLE TV FUND									
254-1088-431.93-01 EQUIPMENT / EQUIPMENT							continued		
1113		07/23	AP	11/22/22	0142132	US BANK	327.22		01/06/23
						B&H PHOTO 800-606-6969			
						2-SHOTGUN MICROPHONES			
						ACCOUNT TOTAL	2,383.19	.00	2,383.19
						FUND TOTAL	5,232.12	.00	5,232.12
FUND 258 PARKING FUND									
258-5531-435.71-01 OFFICE SUPPLIES / OFFICE SUPPLIES									
1042		07/23	AP	12/29/22	0000000	OFFICE EXPRESS OFFICE PRODUCT	.46		01/10/23
						MASKING TAPE			
1042		07/23	AP	12/28/22	0000000	OFFICE EXPRESS OFFICE PRODUCT	1.44		01/10/23
						TAPE,PUTTY			
1042		07/23	AP	12/20/22	0000000	OFFICE EXPRESS OFFICE PRODUCT	1.81		01/10/23
						ENVELOPES, GLUE STICKS			
1042		07/23	AP	12/19/22	0000000	OFFICE EXPRESS OFFICE PRODUCT	1.05		01/10/23
						LEGAL PAPER			
1042		07/23	AP	12/19/22	0000000	OFFICE EXPRESS OFFICE PRODUCT	5.39		01/10/23
						COPY PAPER			
1042		07/23	AP	12/19/22	0000000	OFFICE EXPRESS OFFICE PRODUCT	.26		01/10/23
						PENS			
1085		07/23	AP	12/01/22	0000000	STOREY KENWORTHY	11.50		01/10/23
						#10 REGULAR ENVELOPES			
						ACCOUNT TOTAL	21.91	.00	21.91
258-5531-435.81-48 PROFESSIONAL SERVICES / CONTRACT SERVICES									
1085		07/23	AP	12/31/22	0000000	IPS GROUP, INC	139.31		01/10/23
						GATEWAY FEES-DECEMBER'22			
						(2 PAY STATIONS)			
1085		07/23	AP	12/31/22	0000000	IPS GROUP, INC	3,208.20		01/10/23
						PRKNG CITATION FEES-DEC22			
						ACCOUNT TOTAL	3,347.51	.00	3,347.51
						FUND TOTAL	3,369.42	.00	3,369.42
FUND 261 TOURISM & VISITORS									
261-2291-423.72-99 OPERATING SUPPLIES / POSTAGE									
1087		07/23	AP	12/28/22	0000000	STRATEGIC IMAGING	270.57		01/10/23
						409 ADDRESSED EVELOPES/			
						PROJECT#: 032422			
						NCOA/POSTAGE-GROUP MAILIN			
1113		07/23	AP	11/23/22	0142132	US BANK	23.04		01/06/23
						THE UPS STORE 5189			
						SHIP VISITOR GUIDES TO			
						ACCOUNT TOTAL	293.61	.00	293.61

PREPARED 01/10/2023, 11:21:08
 PROGRAM GM360L
 CITY OF CEDAR FALLS

ACCOUNT ACTIVITY LISTING

PAGE 34
 ACCOUNTING PERIOD 06/2023

GROUP NBR	PO NBR	ACCTG PER.	CD	DATE	---TRANSACTION--- NUMBER	DESCRIPTION	DEBITS	CREDITS	CURRENT BALANCE	POST DT
FUND 261 TOURISM & VISITORS										
261-2291-423.73-53 OTHER SUPPLIES / WEBSITE/CRM										
1087		07/23 AP		01/01/23	0000000	SPINUTECH WEB DESIGN, INC. QTRLY CMS LICENSE/SUPPORT	650.00			01/10/23
						ACCOUNT TOTAL	650.00	.00	650.00	
261-2291-423.73-55 OTHER SUPPLIES / MEDIA										
1087		07/23 AP		12/29/22	0000000	TENSEN, ELLIOT SINGLE USE PHOTO FOR	30.00			01/10/23
						ACCOUNT TOTAL	30.00	.00	30.00	
261-2291-423.73-57 OTHER SUPPLIES / GIFT SHOP										
1087		07/23 AP		12/15/22	0000000	DOLGENER, ALICE 11 CARDS/3 MAGNETS FOR	31.75			01/10/23
1087		07/23 AP		12/15/22	0000000	KENYON, JAMES 3 COW FOR COLLEGE BOOKS	36.00			01/10/23
						ACCOUNT TOTAL	67.75	.00	67.75	
261-2291-423.83-06 TRANSPORTATION&EDUCATION / EDUCATION										
1113		07/23 AP		12/07/22	0142132	US BANK EVENT* 2023 IOWA TOURI	250.00			01/06/23
						PROJECT#: 032426				
						ACCOUNT TOTAL	250.00	.00	250.00	
261-2291-423.83-07 TRANSPORTATION&EDUCATION / REGISTRATIONS										
1113		07/23 AP		12/15/22	0142132	US BANK SQ *IOWA BIKE EXPO	332.50			01/06/23
						PROJECT#: 032420				
						ACCOUNT TOTAL	332.50	.00	332.50	
261-2291-423.85-23 UTILITIES / BUILDING MAINTENANCE										
1087		07/23 AP		12/23/22	0000000	ARAMARK MAT SERVICE	7.80			01/10/23
						ACCOUNT TOTAL	7.80	.00	7.80	
261-2291-423.85-50 UTILITIES / COMMUNITY AWARENESS										
1113		07/23 AP		12/08/22	0142132	US BANK SQ *HERE'S WHAT'S POPPIN	182.50			01/06/23
						ITEMS FOR PROMOTIONAL				
						ACCOUNT TOTAL	182.50	.00	182.50	

PREPARED 01/10/2023, 11:21:08
 PROGRAM GM360L
 CITY OF CEDAR FALLS

ACCOUNT ACTIVITY LISTING

PAGE 35
 ACCOUNTING PERIOD 06/2023

GROUP NBR	PO NBR	ACCTG PER.	CD	---TRANSACTION--- DATE	NUMBER	DESCRIPTION	DEBITS	CREDITS	CURRENT BALANCE POST DT
FUND 261 TOURISM & VISITORS									
261-2291-423.85-51 UTILITIES / EVENTS, BIDS, & SPONSORS									
1087		07/23	AP	12/14/22	0000000	UNIVERSITY OF NORTHERN IOWA	500.00		01/10/23
		2022-2023				TEACHING SERVICES SPONSOR			
1113		07/23	AP	12/12/22	0142132	US BANK	463.50		01/06/23
		SQ *DOLLYS TAXI				TRANSPORT ATTENDEES OF			
		ACCOUNT TOTAL					963.50	.00	963.50
		FUND TOTAL					2,777.66	.00	2,777.66
FUND 262 SENIOR SERVICES & COMM CT									
262-1092-423.72-01 OPERATING SUPPLIES / OPERATING SUPPLIES									
1114		07/23	AP	12/12/22	0142132	US BANK	9.99		01/06/23
		AMZN MKTP US*5C98Z8063	AM			PLAYING CARDS			
1114		07/23	AP	12/12/22	0142132	US BANK	38.97		01/06/23
		AMZN MKTP US*6H1TA0SM3				PLAYING CARD CASES			
		ACCOUNT TOTAL					48.96	.00	48.96
262-1092-423.72-99 OPERATING SUPPLIES / POSTAGE									
1114		07/23	AP	12/15/22	0142132	US BANK	36.00		01/06/23
		USPS PO 1814940913				POSTAGE STAMPS			
		ACCOUNT TOTAL					36.00	.00	36.00
262-1092-423.86-01 REPAIR & MAINTENANCE / REPAIR & MAINTENANCE									
993		07/23	AP	12/23/22	0000000	ARAMARK	7.80		01/10/23
		COMM. CENTER MAT SERVICE							
		ACCOUNT TOTAL					7.80	.00	7.80
		FUND TOTAL					92.76	.00	92.76
FUND 291 POLICE FORFEITURE FUND									
FUND 292 POLICE RETIREMENT FUND									
FUND 293 FIRE RETIREMENT FUND									
FUND 294 LIBRARY RESERVE									
FUND 295 SOFTBALL PLAYER CAPITAL									
295-2253-423.92-01 STRUCTURE IMPROV & BLDGS / STRUCTURE IMPROV & BLDGS									
1122		07/23	AP	12/10/22	0000000	BMC AGGREGATES L.C.	551.83		01/10/23
		BALLFIELD WORK							
1038		07/23	AP	11/30/22	0000000	BMC AGGREGATES L.C.	1,049.63		01/10/23
		BALLFIELD UPGRADES							
		ACCOUNT TOTAL					1,601.46	.00	1,601.46

PREPARED 01/10/2023, 11:21:08
 PROGRAM GM360L
 CITY OF CEDAR FALLS

ACCOUNT ACTIVITY LISTING

PAGE 36
 ACCOUNTING PERIOD 06/2023

GROUP NBR	PO NBR	ACCTG PER.	CD	---TRANSACTION--- DATE	NUMBER	DESCRIPTION	DEBITS	CREDITS	CURRENT BALANCE POST DT
FUND 295 SOFTBALL PLAYER CAPITAL									
					FUND TOTAL		1,601.46	.00	1,601.46
FUND 296 GOLF CAPITAL									
FUND 297 REC FACILITIES CAPITAL									
					297-2253-423.92-01	STRUCTURE IMPROV & BLDGS / STRUCTURE IMPROV & BLDGS			
	1038			07/23 AP 12/09/22	0000000	HUPP ELECTRIC MOTORS PUMPS	9,338.52		01/10/23
					ACCOUNT TOTAL		9,338.52	.00	9,338.52
					FUND TOTAL		9,338.52	.00	9,338.52
FUND 298 HEARST CAPITAL									
FUND 311 DEBT SERVICE FUND									
FUND 402 WASHINGTON PARK FUND									
FUND 404 FEMA									
FUND 405 FLOOD RESERVE FUND									
FUND 407 VISION IOWA PROJECT									
FUND 408 STREET IMPROVEMENT FUND									
FUND 410 CORONAVIRUS LOCAL RELIEF									
FUND 430 2004 TIF BOND									
					430-1220-431.97-64	TIF BOND PROJECTS / VIKING ROAD EXTENSION			
	1042			07/23 AP 12/19/22	0000000	SNYDER & ASSOCIATES, INC.	1,141.25		01/10/23
					3189-W VIKING IND PARK	THROUGH 11/30/22 SURVEY			
					PROJECT#: 023189				
					ACCOUNT TOTAL		1,141.25	.00	1,141.25
					430-1220-431.97-90	TIF BOND PROJECTS / PINNACLE PRAIRIE IMPROVE			
	1042			07/23 AP 12/19/22	0000000	SNYDER & ASSOCIATES, INC.	4,060.00		01/10/23
					3294-PINNACLE ROUNDABOUT	THROUGH 11/30/22			
					PROJECT#: 023294				
					ACCOUNT TOTAL		4,060.00	.00	4,060.00
					430-1220-431.98-48	CAPITAL PROJECTS / HUDSON ROAD/RIDGEWAY INT			
	1042			07/23 AP 12/19/22	0000000	SNYDER & ASSOCIATES, INC.	124.00		01/10/23
					3294-HUDSON & RIDGEWAY	THROUGH 11/30/22			
					PROJECT#: 023294				
					ACCOUNT TOTAL		124.00	.00	124.00
					FUND TOTAL		5,325.25	.00	5,325.25

PREPARED 01/10/2023, 11:21:08
 PROGRAM GM360L
 CITY OF CEDAR FALLS

ACCOUNT ACTIVITY LISTING

PAGE 37
 ACCOUNTING PERIOD 06/2023

GROUP NBR	PO NBR	ACCTG PER.	CD	DATE	TRANSACTION NUMBER	DESCRIPTION	DEBITS	CREDITS	CURRENT BALANCE	POST DT
FUND 431	2014	BOND								
FUND 432	2003	BOND								
FUND 433	2001	TIF								
FUND 434	2000	BOND								
FUND 435	1999	TIF								
FUND 436	2012	BOND								
FUND 437	2018	BOND								
FUND 438	2020	BOND FUND								
438-1220-431.98-23		CAPITAL PROJECTS /				GREENHILL RD & S MAIN INT				
1042	07/23 AP	12/22/22 0000000				SHIVE-HATTERY	402.60			01/10/23
	3228-GREENHILL/S	MAIN INT				SERVICES THROUGH 12/16/22				
PROJECT#:	023228									
	ACCOUNT TOTAL						402.60	.00	402.60	
438-1220-431.98-83		CAPITAL PROJECTS /				CEDAR HGTS DRIVE RECON				
1042	07/23 AP	12/19/22 0000000				SNYDER & ASSOCIATES, INC.	20,458.63			01/10/23
	3171-CEDAR HEIGHTS	RECON				THROUGH 11/30/22				
PROJECT#:	023171									
1042	07/23 AP	12/19/22 0000000				SNYDER & ASSOCIATES, INC.	1,050.25			01/10/23
	3171-CEDAR HEIGHTS	RECON				THROUGH 11/30/22 SURVEY				
PROJECT#:	023171									
	ACCOUNT TOTAL						21,508.88	.00	21,508.88	
	FUND TOTAL						21,911.48	.00	21,911.48	
FUND 439	2022	BOND FUND								
FUND 443		CAPITAL PROJECTS								
443-1220-431.98-88		CAPITAL PROJECTS /				ASHWORTH DR TO HUDSON RD				
1085	07/23 AP	12/28/22 0000000				AHLERS AND COONEY, P.C.	865.00			01/10/23
	LGL:ALDRICH SCHOOL					11/28-12/06/22				
PROJECT#:	023244									
	ACCOUNT TOTAL						865.00	.00	865.00	
	FUND TOTAL						865.00	.00	865.00	
FUND 472		PARKADE RENOVATION								
FUND 473		SIDEWALK ASSESSMENT								
FUND 483		ECONOMIC DEVELOPMENT								

PREPARED 01/10/2023, 11:21:08
 PROGRAM GM360L
 CITY OF CEDAR FALLS

ACCOUNT ACTIVITY LISTING

PAGE 38
 ACCOUNTING PERIOD 06/2023

GROUP NBR	PO NBR	ACCTG PER.	CD	---TRANSACTION--- DATE	NUMBER	DESCRIPTION	DEBITS	CREDITS	CURRENT BALANCE POST DT
FUND 484 ECONOMIC DEVELOPMENT LAND									
484-2245-432.91-10 LAND / INDUSTRIAL PARK LAND ACQ									
1085		07/23 AP		01/06/23	0000000	IOWA REGIONAL UTILITIES ASSOC WATER SERVICE TERRITORY AGREEMENT-ANNEXED PROPERT	199,938.08		01/10/23
						ACCOUNT TOTAL	199,938.08	.00	199,938.08
						FUND TOTAL	199,938.08	.00	199,938.08
FUND 541 2018 STORM WATER BONDS									
FUND 544 2008 SEWER BONDS									
FUND 545 2006 SEWER BONDS									
FUND 546 SEWER IMPROVEMENT FUND									
FUND 547 SEWER RESERVE FUND									
FUND 548 1997 SEWER BOND FUND									
FUND 549 1992 SEWER BOND FUND									
FUND 550 2000 SEWER BOND FUND									
FUND 551 REFUSE FUND									
551-6685-436.72-60 OPERATING SUPPLIES / SAFETY SUPPLIES									
1085		07/23 AP		12/31/22	0000000	BROWN'S SHOE FIT SAFETY SHOES-J BENNETT P.O. 56799	119.99		01/10/23
						ACCOUNT TOTAL	119.99	.00	119.99
551-6685-436.73-01 OTHER SUPPLIES / REPAIR & MAINT. SUPPLIES									
1094		07/23 AP		12/27/22	0000000	O'DONNELL ACE HARDWARE BATTERIES FOR REMOTE CON AND TORCH FOR ROLL OFFS	50.68		01/10/23
1084		07/23 AP		12/19/22	0000000	MENARDS-CEDAR FALLS TOTES FOR SNOW CHAINS	32.97		01/10/23
						ACCOUNT TOTAL	83.65	.00	83.65
551-6685-436.73-05 OTHER SUPPLIES / OPERATING EQUIPMENT									
1094		07/23 AP		11/30/22	0000000	NAPA AUTO PARTS NAPA PARTS	2,716.74		01/10/23
						ACCOUNT TOTAL	2,716.74	.00	2,716.74
551-6685-436.86-36 REPAIR & MAINTENANCE / TRANSFER STATION MAINT.									
1052		07/23 AP		12/16/22	0000000	PLUMB TECH INC. REPAIR TRANSFER STATION FURNANCE	486.60		01/10/23
						ACCOUNT TOTAL	486.60	.00	486.60
551-6685-436.87-02 RENTALS / MATERIAL DISPOSAL/HANDLIN									

PREPARED 01/10/2023, 11:21:08
 PROGRAM GM360L
 CITY OF CEDAR FALLS

ACCOUNT ACTIVITY LISTING

PAGE 39
 ACCOUNTING PERIOD 06/2023

GROUP NBR	PO NBR	ACCTG PER.	CD	DATE	TRANSACTION NUMBER	DESCRIPTION	DEBITS	CREDITS	CURRENT BALANCE	POST DT
FUND 551 REFUSE FUND										
551-6685-436.87-02						RENTALS / MATERIAL DISPOSAL/HANDLIN				continued
1094		07/23 AP		01/02/23	0000000	WEIKERT IRON AND METAL	1,162.00			01/10/23
						APPLIANCE RECYCLING				
1094		07/23 AP		12/23/22	0000000	MIDWEST ELECTRONIC RECOVERY	643.70			01/10/23
						E WASTE RECYCLING				
1052		07/23 AP		12/10/22	0000000	LIBERTY TIRE RECYCLING, LLC	563.51			01/10/23
						SCRAP TIRE RECYCLING				
						ACCOUNT TOTAL	2,369.21	.00	2,369.21	
						FUND TOTAL	5,776.19	.00	5,776.19	
FUND 552 SEWER RENTAL FUND										
552-6655-436.86-12						REPAIR & MAINTENANCE / TOWELS				
1098		07/23 AP		12/23/22	0000000	ARAMARK TOWELS AND MOPS	30.46			01/10/23
						ACCOUNT TOTAL	30.46	.00	30.46	
552-6655-436.96-82						SEWER BOND PROJECTS / OAK PARK SEWER REPLACE				
1042		07/23 AP		12/19/22	0000000	SNYDER & ASSOCIATES, INC.	9,314.50			01/10/23
						3182-OAK PARK SEWER REPL. THROUGH 11/30/22				
		PROJECT#:		023182						
						ACCOUNT TOTAL	9,314.50	.00	9,314.50	
552-6665-436.72-26						OPERATING SUPPLIES / TESTING & LAB				
1098		07/23 AP		12/29/22	0000000	MIDLAND SCIENTIFIC, INC.	36.85			01/10/23
						LAB SUPPLIES				
1098		07/23 AP		12/29/22	0000000	NORTH CENTRAL LABORATORIES	178.68			01/10/23
						LAB SUPPLIES				
						ACCOUNT TOTAL	215.53	.00	215.53	
552-6665-436.72-60						OPERATING SUPPLIES / SAFETY SUPPLIES				
1039		07/23 AP		12/12/22	0000000	GRAINGER PARTS	104.65			01/10/23
						SAFETY SHOES-K LEWIS				
						ACCOUNT TOTAL	104.65	.00	104.65	
552-6665-436.72-68						OPERATING SUPPLIES / POLYMER				
1098		07/23 AP		12/21/22	0000000	MSD ENVIRONMENTAL SERVICES, I	5,057.16			01/10/23
						POLYMER FOR BFP				
						ACCOUNT TOTAL	5,057.16	.00	5,057.16	

PREPARED 01/10/2023, 11:21:08
 PROGRAM GM360L
 CITY OF CEDAR FALLS

ACCOUNT ACTIVITY LISTING

PAGE 40
 ACCOUNTING PERIOD 06/2023

GROUP NBR	PO NBR	ACCTG PER.	CD	TRANSACTION DATE	DESCRIPTION NUMBER	DEBITS	CREDITS	CURRENT BALANCE	POST DT
FUND 552 SEWER RENTAL FUND									
552-6665-436.73-05 OTHER SUPPLIES / OPERATING EQUIPMENT									
1098		07/23 AP		01/04/23	0000000 O'DONNELL ACE HARDWARE	74.97		01/10/23	
					CLEANING SUPPLIES				
1098		07/23 AP		01/04/23	0000000 P & K MIDWEST, INC.	42.32		01/10/23	
					SNOW BLOWER PARTS				
1098		07/23 AP		01/03/23	0000000 MENARDS-CEDAR FALLS	649.00		01/10/23	
					OPERATION REFRIDGERATOR				
1094		07/23 AP		11/30/22	0000000 NAPA AUTO PARTS	183.56		01/10/23	
					NAPA PARTS				
					ACCOUNT TOTAL	949.85	.00	949.85	
552-6665-436.73-06 OTHER SUPPLIES / BUILDING REPAIR									
1098		07/23 AP		12/14/22	0000000 GRAINGER PARTS	345.50		01/10/23	
					HEATER CONTACTOR-BIO BLDG				
					ACCOUNT TOTAL	345.50	.00	345.50	
552-6665-436.73-36 OTHER SUPPLIES / SAN. LIFT STATION SUPP.									
1113		07/23 AP		12/20/22	0142132 US BANK	31.99		01/06/23	
					TRACTOR-SUPPLY-CO #0146 MAT FOR LS HATCH				
					ACCOUNT TOTAL	31.99	.00	31.99	
552-6665-436.86-01 REPAIR & MAINTENANCE / REPAIR & MAINTENANCE									
1098		07/23 AP		12/29/22	0000000 HUPP ELECTRIC MOTORS	3,560.00		01/10/23	
					BIO BLDG DRIVE				
1098		07/23 AP		12/23/22	0000000 BRECKE MECHANICAL CONTRACTORS	274.65		01/10/23	
					BOILER MAINTENANCE				
1098		07/23 AP		12/22/22	0000000 HUPP ELECTRIC MOTORS	1,189.83		01/10/23	
					WASTE GAS BURNER PLC				
1098		07/23 AP		12/15/22	0000000 GEISLER BROTHERS CO.	509.50		01/10/23	
					17TH ST MAU				
					ACCOUNT TOTAL	5,533.98	.00	5,533.98	
552-6665-436.86-29 REPAIR & MAINTENANCE / LAB & TESTING									
1098		07/23 AP		12/30/22	0000000 TESTAMERICA LABORATORIES, INC	962.00		01/10/23	
					LAB TESTING				
					ACCOUNT TOTAL	962.00	.00	962.00	
					FUND TOTAL	22,545.62	.00	22,545.62	

PREPARED 01/10/2023, 11:21:08
 PROGRAM GM360L
 CITY OF CEDAR FALLS

ACCOUNT ACTIVITY LISTING

PAGE 41
 ACCOUNTING PERIOD 06/2023

GROUP NBR	PO NBR	ACCTG PER.	CD	---TRANSACTION--- DATE	NUMBER	DESCRIPTION	DEBITS	CREDITS	CURRENT BALANCE POST DT
FUND 553 2004 SEWER BOND									
FUND 555 STORM WATER UTILITY									
555-6630-432.72-01 OPERATING SUPPLIES / OPERATING SUPPLIES									
1042		07/23	AP	12/29/22	0000000	OFFICE EXPRESS OFFICE PRODUCT	.18		01/10/23
						MASKING TAPE			
1042		07/23	AP	12/28/22	0000000	OFFICE EXPRESS OFFICE PRODUCT	.58		01/10/23
						TAPE,PUTTY			
1042		07/23	AP	12/20/22	0000000	OFFICE EXPRESS OFFICE PRODUCT	.72		01/10/23
						ENVELOPES, GLUE STICKS			
1042		07/23	AP	12/19/22	0000000	OFFICE EXPRESS OFFICE PRODUCT	.87		01/10/23
						LEGAL PAPER			
1042		07/23	AP	12/19/22	0000000	OFFICE EXPRESS OFFICE PRODUCT	4.50		01/10/23
						COPY PAPER			
1042		07/23	AP	12/19/22	0000000	OFFICE EXPRESS OFFICE PRODUCT	.10		01/10/23
						PENS			
1085		07/23	AP	12/01/22	0000000	STOREY KENWORTHY	4.60		01/10/23
						#10 REGULAR ENVELOPES			
						ACCOUNT TOTAL	11.55	.00	11.55
555-6630-432.92-01 STRUCTURE IMPROV & BLDGS / STRUCTURE IMPROV & BLDGS									
1096		07/23	AP	12/29/22	0000000	PETERSON CONTRACTORS	120,243.87		01/10/23
						PROJECT#: 3215-OLIVE ST BOX CULVERT 023215			
						ACCOUNT TOTAL	120,243.87	.00	120,243.87
						FUND TOTAL	120,255.42	.00	120,255.42
FUND 570 SEWER ASSESSMENT									
FUND 606 DATA PROCESSING FUND									
606-1078-441.71-01 OFFICE SUPPLIES / OFFICE SUPPLIES									
1042		07/23	AP	12/19/22	0000000	OFFICE EXPRESS OFFICE PRODUCT	.51		01/10/23
						LEGAL PAPER			
1042		07/23	AP	12/19/22	0000000	OFFICE EXPRESS OFFICE PRODUCT	2.68		01/10/23
						COPY PAPER			
1085		07/23	AP	12/01/22	0000000	STOREY KENWORTHY	2.30		01/10/23
						#10 REGULAR ENVELOPES			
						ACCOUNT TOTAL	5.49	.00	5.49
606-1078-441.72-01 OPERATING SUPPLIES / OPERATING SUPPLIES									
1113		07/23	AP	12/19/22	0142132	US BANK	27.49		01/06/23
						AMZN MKTP US*US4LE4R83 AM PHONE CASE/SCREEN PROTECT			
1113		07/23	AP	12/07/22	0142132	US BANK	349.90		01/06/23
						AMZN MKTP US*S66B63503 WEBCAMS CONFERENCE ROOMS			
1113		07/23	AP	11/30/22	0142132	US BANK	91.12		01/06/23

PREPARED 01/10/2023, 11:21:08
 PROGRAM GM360L
 CITY OF CEDAR FALLS

ACCOUNT ACTIVITY LISTING

PAGE 42
 ACCOUNTING PERIOD 06/2023

GROUP NBR	PO NBR	ACCTG PER.	CD	DATE	TRANSACTION NUMBER	DESCRIPTION	DEBITS	CREDITS	CURRENT BALANCE	POST DT	
FUND 606 DATA PROCESSING FUND											
606-1078-441.72-01 OPERATING SUPPLIES / OPERATING SUPPLIES						continued					
1113		AMZN MKTP	US*HW0TU0Y02	07/23 AP 11/28/22	0142132	RIBBON:ID PRINTER US BANK	32.70			01/06/23	
1113		AMZN MKTP	US*HW4SY8H32	07/23 AP 11/28/22	0142132	TONER - PAT W US BANK	32.70			01/06/23	
1113		AMZN MKTP	US*HW0S93HV2	07/23 AP 11/22/22	0142132	TONER - KEVIN ROGERS US BANK	1,934.73			01/06/23	
		AMZN MKTP	US*HW17Z5ZH1 AM			CHROMEBOOKS-COUNCIL, P&Z					
		ACCOUNT TOTAL					2,468.64	.00		2,468.64	
606-1078-441.81-40 PROFESSIONAL SERVICES / PUBLIC INFORMATION PROG.											
1113		STK*BIGSTOCKPHOTO.COM		07/23 AP 11/28/22	0142132	US BANK	99.00			01/06/23	
		ACCOUNT TOTAL					99.00	.00		99.00	
606-1078-441.81-41 PROFESSIONAL SERVICES / E-GOVERNMENT											
1085		CIMS CLOUD MAINT. RENEW		07/23 AP 01/04/23	0000000	RAMAKER & ASSOCIATES, INC. 3/16/23-3/16/24	2,250.00			01/10/23	
		ACCOUNT TOTAL					2,250.00	.00		2,250.00	
606-1078-441.82-10 COMMUNICATION / TELEPHONE HOLDING ACCOUNT											
1039		COPIERS/24629-MPS01		07/23 AP 12/22/22	0000000	GORDON FLESCH COMPANY 12/22/22-01/21/23	1,083.25			01/10/23	
		ACCOUNT TOTAL					1,083.25	.00		1,083.25	
606-1078-441.86-01 REPAIR & MAINTENANCE / REPAIR & MAINTENANCE											
1113		AMZN MKTP	US*1E6BT0AM3	07/23 AP 12/13/22	0142132	UPS BATTERY REPLACEMENTS US BANK	519.98			01/06/23	
1113		AUTOMATIONDIRECT.COM		07/23 AP 12/12/22	0142132	INDUSTRIAL POWER SUPPLIES US BANK	264.00			01/06/23	
		ACCOUNT TOTAL					783.98	.00		783.98	
606-1078-441.86-10 REPAIR & MAINTENANCE / SOFTWARE SUPPORT AGREEMTS											
1085		AUTOCAD SUBSC/SUPPORT		07/23 AP 01/04/23	0000000	DLT SOLUTIONS, LLC	11,124.48			01/10/23	
1113		ADOBE CREATIVE CLOUD		07/23 AP 12/05/22	0142132	ADOBE CREATIVE CLOUD US BANK	839.76			01/06/23	
		ACCOUNT TOTAL					11,964.24	.00		11,964.24	

PREPARED 01/10/2023, 11:21:08
 PROGRAM GM360L
 CITY OF CEDAR FALLS

ACCOUNT ACTIVITY LISTING

PAGE 43
 ACCOUNTING PERIOD 06/2023

GROUP NBR	PO NBR	ACCTG PER.	CD	-----TRANSACTION----- DATE	NUMBER	DESCRIPTION	DEBITS	CREDITS	CURRENT BALANCE POST DT
FUND 606 DATA PROCESSING FUND									
606-1078-441.93-01 EQUIPMENT / EQUIPMENT									
1113		07/23	AP	11/22/22	0142132	US BANK	185.49		01/06/23
						FOLLOWMEE SERVICE-PARKING			
						ACCOUNT TOTAL	185.49	.00	185.49
						FUND TOTAL	18,840.09	.00	18,840.09
FUND 680 HEALTH INSURANCE FUND									
FUND 681 HEALTH SEVERANCE									
FUND 682 HEALTH INSURANCE - FIRE									
FUND 685 VEHICLE MAINTENANCE FUND									
685-6698-446.72-05 OPERATING SUPPLIES / GAS & OIL									
1094		07/23	AP	01/03/23	0000000	SAM ANNIS & CO.	445.00		01/10/23
						PROPANE			
1094		07/23	AP	12/29/22	0000000	HTP ENERGY	16,398.21		01/10/23
						2200 TECH DIESEL #1			
1094		07/23	AP	12/29/22	0000000	HTP ENERGY	16,402.63		01/10/23
						BLUFF ST DIESEL #1			
1094		07/23	AP	12/29/22	0000000	HTP ENERGY	30,737.96		01/10/23
						2200 TECH DIESEL #1			
1094		07/23	AP	12/29/22	0000000	HTP ENERGY		32,800.84	01/10/23
						CREDIT FOR DIESEL			
1094		07/23	AP	11/30/22	0000000	NAPA AUTO PARTS	903.61		01/10/23
						NAPA PARTS			
1094		07/23	AP	11/11/22	0000000	NORTHLAND PRODUCTS CO.	129.50		01/10/23
						USED OIL COLLECTION			
1094		07/23	AP	11/03/22	0000000	NORTHLAND PRODUCTS CO.	157.00		01/10/23
						USED OIL FILTERS			
						ACCOUNT TOTAL	65,173.91	32,800.84	32,373.07
685-6698-446.72-16 OPERATING SUPPLIES / TOOLS									
1084		07/23	AP	12/13/22	0000000	MENARDS-CEDAR FALLS	29.99		01/10/23
						PLIERS			
						ACCOUNT TOTAL	29.99	.00	29.99
685-6698-446.72-60 OPERATING SUPPLIES / SAFETY SUPPLIES									
1084		07/23	AP	12/16/22	0000000	CITY LAUNDERING CO.	131.41		01/10/23
						FIRST AID SUPPLIES			
						ACCOUNT TOTAL	131.41	.00	131.41
685-6698-446.73-04 OTHER SUPPLIES / VEHICLE SUPPLIES									

PREPARED 01/10/2023, 11:21:08
PROGRAM GM360L
CITY OF CEDAR FALLS

ACCOUNT ACTIVITY LISTING

PAGE 44
ACCOUNTING PERIOD 06/2023

GROUP NBR	PO NBR	ACCTG PER.	CD	DATE	TRANSACTION NUMBER	DESCRIPTION	DEBITS	CREDITS	CURRENT BALANCE	POST DT
FUND 685 VEHICLE MAINTENANCE FUND										
685-6698-446.73-04 OTHER SUPPLIES / VEHICLE SUPPLIES						continued				
1094		07/23	AP	12/22/22	0000000	O'DONNELL ACE HARDWARE	20.25			01/10/23
						#262 BRINE PARTS				
1094		07/23	AP	12/22/22	0000000	TOYNE, INC.	1,457.90			01/10/23
						FD501 SEAT BELT				
1084		07/23	AP	12/21/22	0000000	ALTEC INDUSTRIES, INC.	327.95			01/10/23
						#2186 GAS SHOCKS				
1084		07/23	AP	12/21/22	0000000	LAWSON PRODUCTS, INC.	46.52			01/10/23
						MISC SHOP SUPPLIES				
1094		07/23	AP	12/20/22	0000000	TRACTOR SUPPLY CO.	33.54			01/10/23
						PLOW LATCH PINS				
1113		07/23	AP	12/13/22	0142132	US BANK	55.28			01/06/23
						FLEET FARM 5600 FUEL FILTER AND HOUSING				
1084		07/23	AP	12/12/22	0000000	LAWSON PRODUCTS, INC.	14.36			01/10/23
						MISC SHOP SUPPLIES				
1113		07/23	AP	12/12/22	0142132	US BANK	880.00			01/06/23
						KWIK TRIP 478 00004788 WASH CARDS				
1113		07/23	AP	12/12/22	0142132	US BANK	249.07			01/06/23
						FLEET FARM 5600 FUEL TANK #2107				
1113		07/23	AP	12/12/22	0142132	US BANK	41.99			01/06/23
						FLEET FARM 5600 FUEL TANK #2107				
1094		07/23	AP	11/30/22	0000000	NAPA AUTO PARTS	30,482.65			01/10/23
						NAPA PARTS				
						ACCOUNT TOTAL	33,609.51	.00	33,609.51	
685-6698-446.86-04 REPAIR & MAINTENANCE / RADIO & COMMUNICATIONS										
1094		07/23	AP	12/14/22	0000000	PRECISE MRM LLC	1,020.00			01/10/23
						AVL FEES				
						ACCOUNT TOTAL	1,020.00	.00	1,020.00	
685-6698-446.86-12 REPAIR & MAINTENANCE / TOWELS										
1084		07/23	AP	12/23/22	0000000	ARAMARK	82.45			01/10/23
						SHOP TOWELS				
						ACCOUNT TOTAL	82.45	.00	82.45	
685-6698-446.87-08 RENTALS / WORK BY OUTSIDE AGENCY										
1084		07/23	AP	12/20/22	0000000	D & D TIRE INC.	1,260.00			01/10/23
						#344 TIRES				
1084		07/23	AP	12/19/22	0000000	D & D TIRE INC.	680.00			01/10/23
						#372 TIRES				
1084		07/23	AP	12/19/22	0000000	D & D TIRE INC.	280.00			01/10/23
						#383 TIRES				
1084		07/23	AP	12/19/22	0000000	D & D TIRE INC.	385.00			01/10/23
						#384 TIRES				

PREPARED 01/10/2023, 11:21:08
PROGRAM GM360L
CITY OF CEDAR FALLS

ACCOUNT ACTIVITY LISTING

PAGE 45
ACCOUNTING PERIOD 06/2023

GROUP NBR	PO NBR	ACCTG PER.	CD	DATE	TRANSACTION NUMBER	DESCRIPTION	DEBITS	CREDITS	CURRENT BALANCE	POST DT	
FUND 685 VEHICLE MAINTENANCE FUND											
685-6698-446.87-08 RENTALS / WORK BY OUTSIDE AGENCY						continued					
1084		07/23	AP	12/12/22	0000000	D & D TIRE INC.	180.00			01/10/23	
		#345 TIRES									
1084		07/23	AP	12/12/22	0000000	D & D TIRE INC.	2,620.00			01/10/23	
		FD502 TIRES									
1084		07/23	AP	12/07/22	0000000	D & D TIRE INC.	1,010.00			01/10/23	
		#246 STEERS									
1084		07/23	AP	12/07/22	0000000	D & D TIRE INC.	2,180.00			01/10/23	
		#346 TIRES									
1084		07/23	AP	09/20/22	0000000	MIDWEST OVERHEAD CRANE	156.99			01/10/23	
		CRANE NOISE RESOLVE									
		ACCOUNT TOTAL						8,751.99	.00		8,751.99
		FUND TOTAL						108,799.26	32,800.84		75,998.42
FUND 686 PAYROLL FUND											
FUND 687 WORKERS COMPENSATION FUND											
FUND 688 LTD INSURANCE FUND											
688-1902-457.51-03 INSURANCE / LTD INSURANCE											
1039		07/23	AP	12/22/22	0000000	MADISON NATIONAL LIFE INS.CO.	3,970.02			01/10/23	
		LTD-JAN'23									
		ACCOUNT TOTAL						3,970.02	.00		3,970.02
688-1902-457.51-04 INSURANCE / LIFE INSURANCE											
1039		07/23	AP	12/22/22	0000000	MADISON NATIONAL LIFE INS.CO.	2,493.30			01/10/23	
		GROUP LIFE AD/D JAN'23									
		ACCOUNT TOTAL						2,493.30	.00		2,493.30
		FUND TOTAL						6,463.32	.00		6,463.32
FUND 689 LIABILITY INSURANCE FUND											
689-1902-457.51-05 INSURANCE / LIABILITY INSURANCE											
1085		07/23	AP	12/20/22	0000000	AHLERS AND COONEY, P.C.	2,433.70			01/10/23	
		LGL:SCOTT DIX V. CF 10/25-12/15/22									
		PROJECT#: 012024									
		ACCOUNT TOTAL						2,433.70	.00		2,433.70
		FUND TOTAL						2,433.70	.00		2,433.70

PREPARED 01/10/2023, 11:21:08
PROGRAM GM360L
CITY OF CEDAR FALLS

ACCOUNT ACTIVITY LISTING

PAGE 46
ACCOUNTING PERIOD 06/2023

GROUP	PO	ACCTG	---TRANSACTION---						CURRENT
NBR	NBR	PER.	CD	DATE	NUMBER	DESCRIPTION	DEBITS	CREDITS	BALANCE
									POST DT ---
FUND 724						TRUST & AGENCY			
FUND 727						GREENWOOD CEMETERY P-CARE			
FUND 728						FAIRVIEW CEMETERY P-CARE			
FUND 729						HILLSIDE CEMETERY P-CARE			
FUND 790						FLOOD LEVY			
GRAND TOTAL							823,789.62	33,036.49	790,753.13