



**CITY OF MARSHALL
CITY COUNCIL MEETING
A G E N D A**

Tuesday, April 23, 2019 at 5:30 PM

**Professional Development Room - Marshall Middle School, 401 South
Saratoga Street**

OPENING ITEMS

1. Call to Order/Pledge of Allegiance

APPROVAL OF AGENDA

APPROVAL OF MINUTES

2. Consider approval of the minutes of the work session and regular meeting held on April 9, 2019.
3. Consider approval of the minutes of local board of appeal and equalization hearing held on April 15, 2019.

PUBLIC HEARING

AWARD OF BIDS

4. Project Z51-2019: Bituminous Resurfacing on Various City Streets - Consider Resolution Accepting Bid.
5. Project Z74: Huron Road/Superior Road Reconstruction Project - Consider Resolution Accepting Bid.
6. Consider Bids for Award of Liberty Park Restroom project

CONSENT AGENDA

7. Consider Amendments to the Fund Balance Policy
8. Consider Approval of Amendments to Interfund Loan Resolution for TIF 1-5 for Marshall Hotel Project
9. Consider approval of a Refuse Haulers License for West Central Sanitation, INC. of Willmar, MN.
10. Consider approval of Transient Merchant License for Frankie's Hot Dogs, LLC
11. Consider authorization to declare vehicles as surplus property for the Marshall Police Department.
12. Commerce Industrial Park Farm Lease - 2019.
13. Authorization of acceptance of a HMEP Grant for the Southwest Chemical Assessment Team and to authorize the Director of Public Safety/Police Chief Jim Marshall to administer the grant.
14. Consider an application for an On-Sale Intoxicating Liquor License for Marshall Convention and Visitors Bureau for May 17, 2019.
15. Consider approval of the bills/project payments

APPROVAL OF ITEMS PULLED FROM CONSENT

OLD BUSINESS

TABLED ITEM

NEW BUSINESS

16. Introduce the request for map amendment (rezone) of James Carr, Marshall, MN, at 701, 703, 705, 800, 801, 802, 803, 804, 805, 806, 807, 900, 901, 902, 903, 904 and 905 Andrew Street.
17. Request for map amendment (rezone) 1213, 1215 and 1217 West Main Street.
18. Legion Field Stormwater Study - Report Update from Bolton & Menk, Inc.
19. 2018 Marshall Area EDA Annual Report
20. Consider the annual adoption of a Resolution Declaring the Sounds of Summer as a Community Festival.
21. Call for Public Hearing for Private Use of Public Streets and Parking Lots for Sounds of Summer – August 16-18, 2019.

Disclaimer: These agendas have been prepared to provide information regarding an upcoming meeting of the Common Council of the City of Marshall. This document does not claim to be complete and is subject to change.

- [22.](#) Consider approval of a letter of support for the Marshall Cemetery Association
- [23.](#) Commerce Industrial Park Second Addition Dedication of Public Roadway and Utility Easements

COUNCIL REPORTS

- [24.](#) Commission/Board Liaison Reports
- 25. Councilmember Individual Items

STAFF REPORTS

- 26. City Administrator
- [27.](#) Director of Public Works
- 28. City Attorney

ADMINISTRATIVE REPORTS

INFORMATION ONLY

- [29.](#) Information Only

ADJOURN TO CLOSED SESSION

MEETINGS

- [30.](#) Upcoming Meetings

ADJOURN

- 31. Adjourn Meeting

RULES OF CONDUCT

- You may follow the meeting online – www.ci.marshall.mn.us.
- Public Hearing – the general public shall have the opportunity to address the Council.
 - Approach the front podium
 - State your name, address and interest on the subject
- Mayor may choose to allow others to address the Council during other agenda items. Persons who desire to speak should do so only after being recognized by the Mayor.
 - Approach the front podium
 - State your name, address and interest on the subject
- Persons in attendance at the meeting should refrain from loud discussions among themselves, clapping, whistling or any other actions. Our values include mutual respect and civility for all in attendance.
- If you have questions during the Council meeting please see Kyle Box, City Clerk who sits in the front left area of the audience sitting area.



CITY OF MARSHALL AGENDA ITEM REPORT

Meeting Date:	Tuesday, April 9, 2019
Category:	APPROVAL OF MINUTES
Type:	ACTION
Subject:	Consider approval of the minutes of the work session and regular meeting held on April 9, 2019.
Background Information:	Enclosed are the minutes of the work session and regular meeting held on April 9, 2019
Fiscal Impact:	None
Alternative/ Variations:	Staff encourages City Council Members to provide any suggested corrections to the minutes in writing to City Clerk Kyle Box, prior to the meeting. We then could potentially incorporate proposed amended minutes at the meeting.
Recommendations:	that the minutes of the work session and regular meeting held on April 9, 2019 be approved as filed with each member and that the reading of the same be waived.

**CITY OF MARSHALL
WORK SESSION
M I N U T E S
Tuesday, April 09, 2019**

A Work Session of the Common Council of the City of Marshall was held on April 9, 2019 in the Professional Development Room at the Marshall Middle School, 401 South Saratoga Street. The meeting was called to order at 4:00 P.M. by Mayor Bob Byrnes. In addition to Byrnes the following members were present: Craig Schafer, Steven Meister (4:10 PM), Glenn Bayerkohler (4:10 PM), John DeCramer, Russ Labat and James Lozinski. Absent: None. Staff present included: Sharon Hanson, City Administrator; Sheila Dubs, Human Resource Manager; Director of Public Works/City Engineer Glenn Olson; Zoning Administrator/Assistant City Engineer; Director of Administrative Services, Annette Storm; Director of Community Services, Scott VanDerMillen and City Clerk, Kyle Box.

2019 Capital Improvements

Director of Public Works provided discussion on future Mill and Overlay projects within the City of Marshall. Director Olson commented that there will be a bid opening for on April 18, 2019 regarding these projects.

City Administrator Sharon Hanson opened discussion on several items on future capital improvement projects within the City of Marshall. There was further discussion by Council and staff on the priority items, alley improvements, park bathrooms to be located in Liberty Park and discussion on an additional parking lot located at the Red Baron Arena.

Long Term Financial Plan.

Director of Administrative Services, Annette Storm introduced the item to Council and provided an update.

Consider Amendments to the Fund Balance Policy

Director of Administrative Service, Annette Storm provided discussion on the item. There was a consensus by the Council to hold off on this item until the April 23, 2019 meeting.

ADJOURNMENT

At 4:56 P.M., Councilmember Lozinski Motioned, Seconded by Councilmember Labat to adjourn. Voting Yea: Mayor Byrnes, Councilmember Schafer, Councilmember Meister, Councilmember Bayerkohler, Councilmember Decramer, Councilmember Labat, Councilmember Lozinski. The motion **Carried. 7-0**

Mayor

Attest:

**CITY OF MARSHALL
CITY COUNCIL MEETING
M I N U T E S
Tuesday, April 09, 2019**

The regular meeting of the Common Council of the City of Marshall was held April 9, 2019 in the Professional Development Room at the Marshall Middle School, 401 South Saratoga Street. The meeting was called to order at 5:30 P.M. by Mayor Robert Byrnes. In addition to Byrnes the following members were in attendance: Craig Schafer, Steven Meister, Glenn Bayerkohler John DeCramer, Russ Labat and James Lozinski. Absent: None. Staff present included: Sharon Hanson, City Administrator; Dennis Simpson, City Attorney; Glenn Olson, Director of Public Works/City Engineer; Jason Anderson, Assistant City Engineer/Zoning Administrator; Ilya Gutman, Plan Examiner/Assistant Zoning Administrator; Jim Marshall, Director of Public Safety; Annette Storm, Director of Administrative Services; Sheila Dubs, Human Resource Manager; Scott VanDerMillen, Director of Community Services; Preston Stensrud, Parks Superintended and Kyle Box, City Clerk.

The Pledge of Allegiance was recited at this time.

With consensus from the Council Mayor Byrnes requested to remove item number 14, Consider Amendments for the Fund Balance Policy and item number 19, Request for map amendment (rezone) 1213, 1215 and 1217 West Main Street. Mayor Byrnes also requested that item number 20, Request for a condition use permit for Carr Family LTD Partnership, at 405 Country Club Drive immediately follow the approval of the minutes.

Consider approval of the minutes of the regular meeting held on March 26, 2019.

Motion made by Councilmember Labat, Seconded by Councilmember Lozinski that the minutes of the regular meeting held on March 26, 2019 be approved as filed with each member and that the reading of the same be waived. Voting Yea: Mayor Byrnes, Councilmember Meister, Councilmember Bayerkohler, Councilmember DeCramer, Councilmember Labat, Councilmember Lozinski. The motion **Carried. 7-0**

REQUEST FOR CONDITIONAL USE PERMIT for Carr Family LTD Partnership, at 405 Country Club Drive.

Mayor Robert Byrnes submitted a written letter on behalf of the applicant, Carr Family LTD Partnership, to the Council requesting the withdrawal for the conditional use permit request.

Anderson Addition – Public Hearing on Preliminary Plat, Approval of the Preliminary Plat and Consider a Resolution Adopting the Final Plat.

As a portion of the property has not been platted before and some of the property is included in separate subdivisions, the property needs to be replatted. The property owner wishes to construct an addition to his existing building located within the Marshall Right of Way Addition and by doing so would encroach into properties not within the subdivision, a copy of which is attached. Attached please find a copy of the Engineer's Report of Preliminary Plat Review. Copies of the proposed subdivision have been sent to the local utility companies for their review and comments. At the Planning Commission meeting on March 13, 2019, Ruud made a motion, seconded by Knieff to recommend approval of the preliminary plat to the City Council. All voted in favor.

Motion made by Councilmember DeCramer, Seconded by Councilmember Labat to close the public hearing on the Preliminary Plat of Anderson Addition. Voting Yea: Mayor Byrnes, Councilmember Schafer, Councilmember Meister, Councilmember Bayerkohler, Councilmember DeCramer, Councilmember Labat, Councilmember Lozinski. The motion **Carried. 7-0**

Motion made by Councilmember Schafer, Seconded by Councilmember Lozinski to approve the Preliminary Plat of Anderson Addition. Voting Yea: Mayor Byrnes, Councilmember Schafer, Councilmember Meister, Councilmember Bayerkohler, Councilmember DeCramer, Councilmember Labat, Councilmember Lozinski. The motion **Carried. 7-0**

Motion made by Councilmember DeCramer, Seconded by Councilmember Lozinski to adopt RESOLUTION NUMBER 4603, which is the Resolution Adopting the Final Plat of Anderson Addition, subject to City Attorney review of abstract of title and title opinion. Voting Yea: Mayor Byrnes, Councilmember Schafer, Councilmember Meister, Councilmember Bayerkohler, Councilmember DeCramer, Councilmember Labat, Councilmember Lozinski. The motion **Carried. 7-0**

305 Brussels Ct. – Public Hearing regarding a home property tax abatement request and Consideration of Resolution Number 4604, Second Series, a resolution approving home property tax abatement.

On March 26, 2019 a public hearing was called for and to be held on April 9, 2019 regarding a home property tax abatement request. Per M.S 469.1813 sub 5 The governing body of the political subdivision may approve an abatement under sections 469.1812 to 469.1815 only after holding a public hearing on the abatement. The property is located at 305 Brussels Ct. with an estimated market value of \$158,900 with the difference of improvement being \$146,900.

City Clerk Kyle Box opened introduced the item to Council. City Assessor Dave Parsons provided information regarding the difference between the homestead and non-homestead tax rates.

Motion made by Councilmember Labat, Seconded by Councilmember Meister to Close the Public Hearing. Voting Yea: Mayor Byrnes, Councilmember Schafer, Councilmember Meister, Councilmember Bayerkohler, Councilmember DeCramer, Councilmember Labat Voting Abstaining: Councilmember Lozinski. The motion **Passed. 6-0-1**

Motion made by Councilmember Meister, Seconded by Councilmember Labat to approve Resolution Number 4604, Second Series, a resolution approving home property tax abatement Voting Yea: Mayor Byrnes, Councilmember Schafer, Councilmember Meister, Councilmember DeCramer, Councilmember Labat Voting Nay: Councilmember Bayerkohler. Voting Abstaining: Councilmember Lozinski. The motion **Passed. 5-1-1**

307 Brussels Ct. – 1) Public Hearing regarding a home property tax abatement request and Consideration of Resolution Number 4605, Second Series, a resolution approving home property tax abatement.

On March 26, 2019 a public hearing was called for and to be held on April 9, 2019 regarding a home property tax abatement request. Per M.S 469.1813 sub 5 The governing body of the political subdivision may approve an abatement under sections 469.1812 to 469.1815 only after holding a public hearing on the abatement. The property is located at 307 Brussels Ct. with an estimated market value of \$167,300 with the difference of improvement being \$155,300.

Motion made by Councilmember DeCramer, Seconded by Councilmember Labat to Close the Public Hearing. Voting Yea: Mayor Byrnes, Councilmember Schafer, Councilmember Meister, Councilmember Bayerkohler, Councilmember DeCramer, Councilmember Labat. Voting Abstaining: Councilmember Lozinski. The motion **Passed. 6-0-1**

Motion made by Councilmember Meister, Seconded by Councilmember Labat to approve Resolution Number 4605, Second Series, a resolution approving home property tax abatement. Voting Yea: Mayor Byrnes, Councilmember Schafer, Councilmember Meister, Councilmember DeCramer, Councilmember Labat. Voting Nay: Councilmember Bayerkohler. Voting Abstaining: Councilmember Lozinski. The motion **Passed. 5-1-1**

Approval of Consent Agenda

Motion made by Councilmember Meister, Seconded by Councilmember Labat that the following consent agenda items be approved as presented. Voting Yea: Mayor Byrnes, Councilmember Schafer, Councilmember Meister, Councilmember Bayerkohler, Councilmember DeCramer, Councilmember Labat, Councilmember Lozinski. The motion **Carried. 7-0**

Approval of Resolution Number 4606, a Resolution Authorizing Transfer of funds from Fund 495 to Fund 602.

Approval of the Fire Township Agreements

Approval to Declare Surplus Property from Building Maintenance.

Approval of Resolution Number 4607, a Resolution Authorizing Transfer of Funds from Fund 101 to Fund 495

Approval of an Off-Sale 3.2 Percent Malt Liquor License and Tobacco License for I Mart Stores, LLC., 304 East College Dr., Marshall, MN.

Approval of the bills/project payments

REQUEST FOR A VARIANCE ADJUSTMENT PERMIT BY L2A, LLC, AT 501 Village Drive.

Several apartment complexes in Marshall have recently been purchased by Suite Liv'n Company. They want to add a new apartment building at the back of the 501-517 Village Drive development. There are already 6 buildings there so the options for new building location are limited. Zoning Ordinance requires a rear yard to be 25% of the entire lot depth, which in this case will be about a hundred feet. The owner is asking to reduce it to 30 feet.

An apartment building on the property directly south is located within 10 feet from the rear property line, based on a variance approved in 1992. Considering this information and the fact that adjacent property to the west is zoned A – Agricultural District and used as a cemetery, this request seems reasonable.

The variance regulations and procedures are found in Section 86-29 A property aerial photo and a proposed site plan is attached for reference.

At the Planning Commission meeting on March 28, 2019, a motion was made by Fox, second by Knieff to recommend approval to the City Council of the request by L2A, LLC for a Variance Adjustment Permit for reduction of the required rear yard from 25% of the lot depth, or about 100 feet, to 30 feet as recommended by staff. All voted in favor of the motion.

Motion made by Councilmember DeCramer, Seconded by Councilmember Lozinski to approve the request by L2A, LLC for a Variance Adjustment Permit for reduction of the required rear yard from 25% of the lot depth

or about 100 feet, to 30 feet. Voting Yea: Mayor Byrnes, Councilmember Schafer, Councilmember Meister, Councilmember Bayerkohler, Councilmember DeCramer, Councilmember Labat, Councilmember Lozinski. The motion **Carried. 7-0**

Consider a resolution amending Resolution No. 4430, Second Series, in support of chloride reduction in water discharged to the Redwood River.

On September 26, 2017, Marshall City Council approved Resolution No. 4430, Second Series, a resolution in support of chloride reduction in water discharged to the Redwood River. The 2017 resolution supported the development by MMU and its consultants for the development of plans for new pretreatment of water system for the City of Marshall. The anticipated costs of the project at that time totaled \$9,043,000. Of that amount, MMU submitted an application hoping to receive \$7M grant to pay for the majority of the improvement costs. Grant application was submitted through the Point Source Implementation Grant (PSIG) process. The prior application, however, was denied and the PSIG funds were not dispersed to the MMU. MMU, however, has continued to develop the proposed plans and has now submitted a “certified plan” for the development of a water system for pretreatment of water. PSIG has now approved the \$7M grant to the MMU.

The plans have continued to develop, and it is anticipated that the costs of the project are now \$10,606,000. The majority of those costs are to be paid by the \$7M PSIG grant. Discussions have ensued between MMU and the City as to the appropriate parties to pay the remaining \$3,606,000 of the project. The resolution as proposed divides those remaining costs 55.74% to the City of Marshall and 44.26% to MMU. City’s anticipated costs based upon engineer’s estimate would be \$2,009,984. MMU’s costs would be \$1,596,016. Project is to be bid by MMU on June 11, 2019.

MMU General Manager Brad Roos, Bob VanMoer, Wastewater Superintendent and Glenn Olson, Director of Public Works/City Engineer will be present to discuss this matter. Various documents and presentations have been submitted in connection with the project.

Motion made by Councilmember Labat, Seconded by Councilmember DeCramer to approve Resolution Number 4608, Second Series amending Resolution No. 4430, Second Series, a resolution in support of chloride reduction in water discharged to the Redwood River. Voting Yea: Mayor Byrnes, Councilmember Schafer, Councilmember Meister, Councilmember Bayerkohler, Councilmember DeCramer, Councilmember Labat, Councilmember Lozinski. The motion **Carried. 7-0**

Approve Strategic Planning Services.

The City of Marshall desires to conduct a survey and focus groups with city stakeholders in order to build ownership and create a 3-year strategic plan for the city. The strategic plan will be created by the city council and city administrator in a 5-hour retreat facilitated by Vantage Point Marketing Consultants. During this retreat a detailed 3-year strategic plan, grounded in the survey results, will be developed, including action plans and accountability marks for each key goal.

Motion made by Councilmember Schafer, Seconded by Councilmember Lozinski to approve Strategic Planning Services with Vantage Point Marketing Consultants in the amount of \$17,500. Voting Yea: Mayor Byrnes, Councilmember Schafer, Councilmember DeCramer, Councilmember Labat, Councilmember Lozinski
Voting Nay: Councilmember Meister, Councilmember Bayerkohler. The motion **Passed. 5-2**

Consider approval of Consumption and Display License for Southwest Minnesota State University.

Motion made by Councilmember DeCramer, Seconded by Councilmember Meister to approval of the annual renewal of the Consumption and Display License for Southwest Minnesota State University for the period April 1, 2019 through March 31, 2020 at a fee of \$130.00. Voting Yea: Mayor Byrnes, Councilmember Schafer, Councilmember Meister, Councilmember DeCramer, Councilmember Labat, Councilmember Lozinski. Voting Abstaining: Councilmember Bayerkohler. The motion **Passed. 6-0-1**

Commission/Board Liaison Reports

Byrnes No Report

Schafer No Report

Meister No Report

DeCramer No Report

Labat Library Board met and discussed their final budge for 2018. The Library also posted its 2nd newsletter.
Police Advisory Committee met and conducted interviews for the Police Captain position.

Lozinski No Report

Councilmember Individual Items

Councilmember Lozinski commented on the discussion revolving around the conditional use permit item pulled from the agenda.

Councilmember Labat discussed the City’s future focus on the Comprehensive Plan to potentially avoid controversial items.

Councilmember DeCramer continued the discussion related to the conditional use permit item pulled from the agenda. Councilmember DeCramer believes that current zoning of the property, B-3, is correctly zoned and would allow the business to be there.

Councilmember Schafer brought up a discussion he had with an individual regarding September 11, 2001. The person that he met with documents memorials dedicated to 9/11. Councilmember Schafer commented that he is very proud to be involved with the 9/11 memorial located in memorial park. Member Schafer also discussed the conditional use item pulled from the agenda.

Councilmember Bayerkohler discussed the conditional use permit that was pulled from the agenda. Member Bayerkohler mentioned that he was against the conditional use permit and understood the action to be against the City ordinance. Member Bayerkohler commented that he is for economic development but in a fair and legal way.

Mayor Byrnes reminded all that the conditional use permit request never did come to the City Council as it was withdrawn from the applicant prior to the meeting. Mayor Byrnes outlined in the letter received by the

business owner and his decision not to bring his business to the City of Marshall. Mayor Byrnes discussed strategic planning for the City of Marshall to change the perception of the City of Marshall.

City Administrator

City Administrator Sharon Hanson discussed the legal opinion from the City of Marshall and its City Attorney as well as outside legal counsel. Administrator Hanson mentioned that the Weather Channel will be covering the upcoming weather event.

Mayor Byrnes recognized Greg Taylor to speak on the business atmosphere in the City. Mr. Taylor discussed several items regarding the business involved with the conditional use permit and the need for business growth in the City.

Director of Public Works

Director of Public Works/City Engineer Glenn Olson discussed the Public Works schedule for the upcoming snow event. Director Olson also discussed the Redwood River water levels and limited parking on snow emergency routes during the snow event.

City Attorney

City Attorney Dennis Simpson discussed the legal opinion from his office regarding the condition use permit pulled from the agenda.

Administrative Report

There were no questions on the Administrative Report.

Information Only

There were no questions on the information items.

Upcoming Meetings

There were no questions on the upcoming meetings.

Adjourn Meeting

At 6:54 P.M., Motion made by Councilmember Schafer, Seconded by Councilmember Meister.
Voting Yea: Mayor Byrnes, Councilmember Schafer, Councilmember Meister, Councilmember Bayerkohler, Councilmember DeCramer, Councilmember Labat, Councilmember Lozinski

Mayor

Attest:

City Clerk



CITY OF MARSHALL AGENDA ITEM REPORT

Meeting Date:	Tuesday, April 9, 2019
Category:	APPROVAL OF MINUTES
Type:	ACTION
Subject:	Consider approval of the minutes of local board of appeal and equalization hearing held on April 15, 2019.
Background Information:	Enclosed are the minutes of local board of appeal and equalization hearing held on April 15, 2019.
Fiscal Impact:	None
Alternative/ Variations:	Staff encourages City Council Members to provide any suggested corrections to the minutes in writing to City Clerk Kyle Box, prior to the meeting. We then could potentially incorporate proposed amended minutes at the meeting.
Recommendations:	that the minutes of local board of appeal and equalization hearing held on April 15, 2019 be approved as filed with each member and that the reading of the same be waived.

Minutes of the City of Marshall Local Board of Appeal and Equalization
5:30 p.m. – April 15, 2019

Local Board of Appeal and Equalization Members Present: Robert Byrnes, John DeCramer, Glenn Bayerkohler, Russ Labat, Craig Schafer, James Lozinski.

Local Board of Appeal and Equalization Members absent: Meister

Staff Present: David Parsons, Carolyn Runholt, Doris Huber

Other Staff Present: Sharon Hanson, City Administrator, Kyle Box, City Clerk, Sherri Kitchenmaster, Lyon County Assessor

The 2019 City of Marshall Local Board of Appeal and Equalization (LBAE) was called to order at 5:30 p.m. by Mayor Byrnes in the Community Room of the Marshall Lyon County Library at 201 C Street. Mayor Byrnes outlined the purpose of the meeting, which was to review the January 2, 2019 valuations and classifications. The meeting was then turned over to City Assessor Parsons. Assessor Parsons reviewed the assessment process and other background information for the 2019 assessment. All work must be completed by the LBAE no later than May 6, 2019. After the presentation, there were no questions from the Board.

Mayor Byrnes requested the members of the public present to state their name, address, and address of the property in question, and their reason for being present.

Frances Remerowski

Parcels: 27-148011-0 – 400 Genesis Avenue

27-145023-0 – 27-145024-0 – 27-145025-0 – 609 Cadillac Road

Mr. Remerowski was concerned with a \$30,000 value increase for 400 Genesis Avenue. Assessor Parsons indicated the properties on Genesis Avenue were increased because of sales in the area. All of Genesis Avenue had a location factor applied because of the Mobile Home Park and the Carr Addition. According to recent sales, the location factor had to be removed. Assessor Parsons indicated the Genesis property was an estimate and we could not do anything until we reviewed the property. Mr. Remerowski set up an appointment on April 16, 2019 at 9:00 am to have the Genesis property reviewed. No appointment was made for the property at 609 Cadillac Road which is also an estimate. The property will be reviewed and brought back to the LBAE at the reconvene meeting.

Carr Family Ltd Partnership

Parcels: 27-566017-0 – 27-566018-0 – 405 Country Club Drive

A memo was sent to the LBAE reviewing the property based upon Assessor's Parsons inspection. Mayor Byrnes asked if Mr. Carr was agreement with the memo. Mr. Carr was OK with the proposal. Lozinski questioned why the building was higher than Kruse Motors. Kruse Motors was \$13.14 per square foot Parsons indicated this was sale price, not estimated market value. Labat wanted the square footage of the Kruse building which is 16,360 square feet. Lozinski indicated the Kruse Motors building is on a commercial street and County Fair is in a residential area. County Fair must be sold for a retail purpose now, which makes it tough to value. Bayerkohler commented the Assessor has established a new value with his inspection. This is the most current information available. Bayerkohler questioned if one rate was used throughout town. Assessor Parsons said no, it is based on neighborhoods. There was no further discussion. Motion by Schaefer, seconded by Labat to reduce the proposed 2019 Estimated Market Value of Parcel 27-566017-0 – 405 Country Club Drive from \$560,400 to \$376,000 on Parcel 27-566017-0. All voted in favor of the motion except Lozinski who voted No. Motion Passed.

Motion by Schaefer, seconded by DeCramer to reduce the proposed 2019 Estimated Market Value of Parcel 27-566018-0 – 405 Country Club Drive from \$120,000 to \$74,500 on Parcel 27-566018-0. All voted in favor of the motion except Lozinski who voted No. Motion Passed.

The LBAE received a list of property owners with Assessor’s recommendations for change. Mayor Byrnes reviewed each of the recommendations as follows:

27-209002-0 – Mark & Tracy Veglahn – 624 Kathryn Avenue. Motion by Schaefer, seconded by Lozinski, to reduce the 2019 proposed estimated market value from \$151,400 to \$119,400. Assessor Parsons indicated this was an estimate which had been inspected. ALL VOTED IN FAVOR OF THE MOTION.

27-708035-0 – Alvin & Lois Evers – 605 Arbor Court - Motion by DeCramer, seconded by Lozinski, to reduce the 2019 proposed estimated market value from \$228,300 to \$206,600. Bayerkohler questioned the reason for the decrease. The property had water damage in the basement. This is a continuation of the 2016 water problem. ALL VOTED IN FAVOR OF THE MOTION.

The following people attended the meeting and will be contacted by the Assessor’s office and property reviewed if requested.

Darwin & Jean Leek – 205 Carrow Street – 27-837033-0

Kristin Miller – 123 E Street – 27-751012-0

Shailendra Patel – 1106 East Main Street – 27-605004-0

Misty Butler – 127 E Street – 27-751014-0

Mike Fox – no particular parcel. Looking for information only.

The meeting was recessed at 6:25 pm. The reconvene meeting will be on April 23, 2019, at the Marshall Middle School, 401 East Saratoga Street, Professional Development Room at 5:00 pm. At that time, the LBAE will receive and act upon recommendations.

Mayor

Attest:

City Clerk



CITY OF MARSHALL AGENDA ITEM REPORT

Meeting Date:	Tuesday, April 23, 2019
Category:	AWARD OF BIDS
Type:	ACTION
Subject:	Project Z51-2019: Bituminous Resurfacing on Various City Streets - Consider Resolution Accepting Bid.
Background Information:	<p>Bids were received on April 16, 2019 for the above-referenced project. Duininck, Inc. of Prinsburg, Minnesota, was the lowest responsible bidder as shown on the attached resolution.</p> <p>Attached is a map showing the proposed affected street segments.</p> <p>Attached is the “Resolution Accepting Bid” awarding the contract to Duininck, Inc. of Prinsburg, Minnesota, in the amount of \$537,234.20, with a maximum of \$575,000.00.</p>
Fiscal Impact:	The engineer’s estimate for the bituminous overlay was approximately \$582,600. At the CIP work session on April 9, 2019, approximately \$575,000 was approved.
Alternative/ Variations:	No alternative actions recommended.
Recommendations:	that the Council adopt RESOLUTION NUMBER XXXX, which is the “Resolution Accepting Bid (Award Contract)” for Project Z51-2019: Bituminous Overlay on Various City Streets to Duininck, Inc. of Prinsburg, Minnesota, in the amount of \$537,234.20, with a maximum of \$575,000.00.

RESOLUTION NUMBER _____, SECOND SERIES

RESOLUTION ACCEPTING BID (AWARD CONTRACT)

WHEREAS, pursuant to an advertisement for bids for Project Z51-2019: 2019 Bituminous Overlay Project, bids were received, opened and tabulated according to law, and the following bids were received complying with the advertisement for bids:

Bidder	Bid Amount
Duininck, Inc. Prinsburg, Minnesota	\$537,234.20
Central Specialties, Inc. Alexandria, Minnesota	\$617,112.75

AND WHEREAS, it appears that Duininck, Inc. of Prinsburg, Minnesota, is the lowest responsible bidder.

NOW THEREFORE, BE IT RESOLVED BY THE CITY COUNCIL OF MARSHALL, MINNESOTA:

1. The Mayor and City Clerk are hereby authorized and directed to enter into a contract with Duininck, Inc. of Prinsburg, Minnesota, in the name of the City of Marshall for Project Z51-2019, in the amount of \$537,234.20, with a maximum of \$575,000.00, according to the plans and specifications on file in the office of the City Clerk.

Passed and adopted by the Council this 23rd day of April, 2019.

Mayor

ATTEST:

City Clerk

This Instrument Drafted by:
Glenn J. Olson, P.E.
Director of Public Works/City Engineer

STATE OF MINNESOTA CITY OF MARSHALL, MINNESOTA

Construction Plans for Bituminous Overlays & Pedestrian Ramps
within the City of Marshall

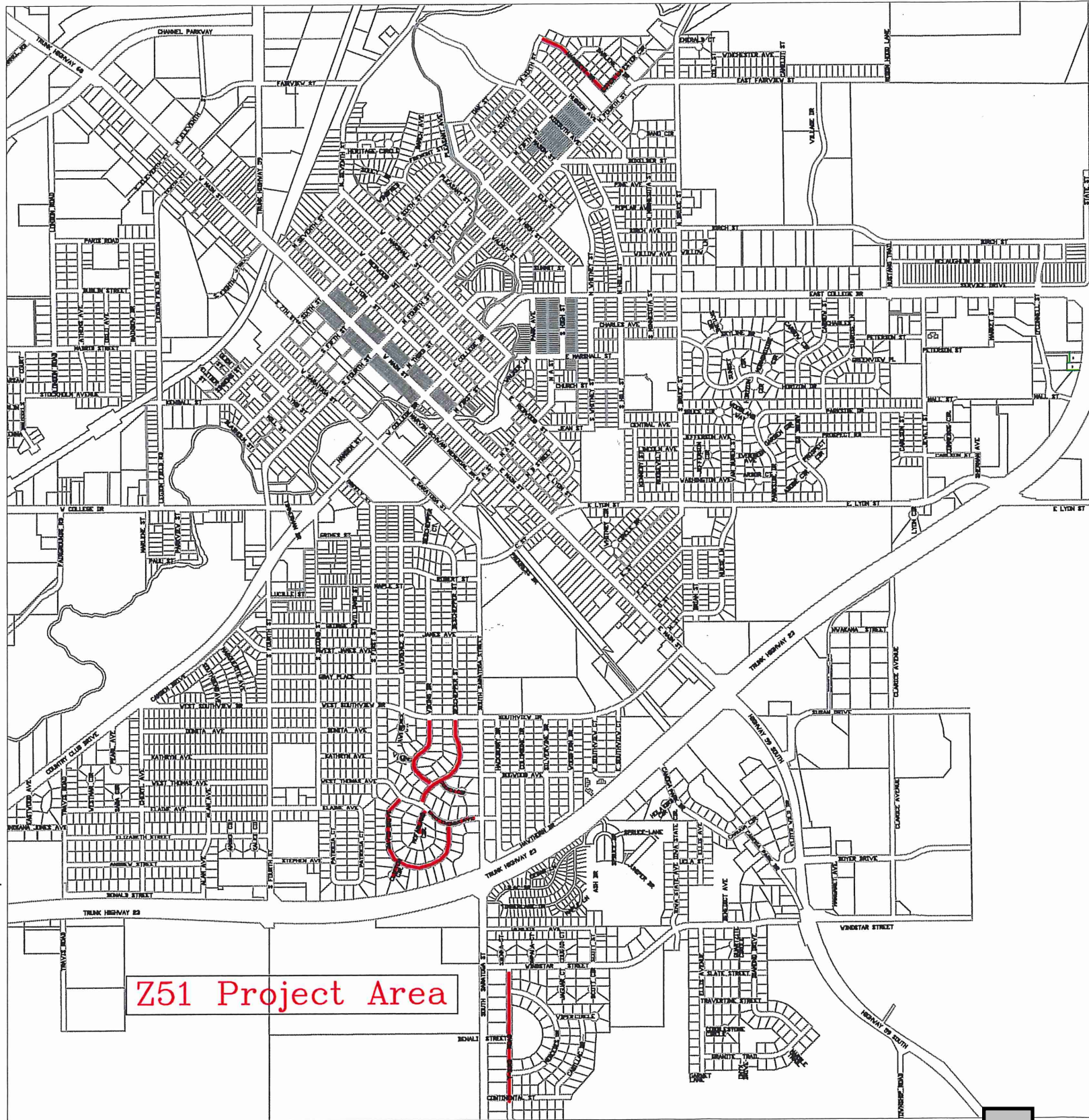

Z51 Project Area



CITY OF MARSHALL AGENDA ITEM REPORT

Meeting Date:	Tuesday, April 23, 2019
Category:	AWARD OF BIDS
Type:	ACTION
Subject:	Project Z74: Huron Road/Superior Road Reconstruction Project - Consider Resolution Accepting Bid.
Background Information:	<p>Bids were received on April 18, 2019 for the above-referenced project. R&G Construction Co. of Marshall, Minnesota, was the lowest responsible bidder as shown on the attached resolution. Attached is a map showing the project area.</p> <p>MMU has reviewed the bids and has concurred with a recommendation to award the contract to R&G Construction Co. MMU will be responsible for all watermain, services up to and including the curb stop/valve, and all base and surfacing costs above these items.</p> <p>Attached is the "Resolution Accepting Bid" awarding the contract to R&G Construction Co. of Marshall, Minnesota in the amount of \$787,018.00.</p>
Fiscal Impact:	The estimated total project cost including 5% allowance for contingencies and 16% for engineering and administrative costs is \$958,587.92 funded from Account #260-60211-5570. The engineer's estimate for the project was approximately 1,038,800.00.
Alternative/Variations:	No alternative actions recommended.
Recommendations:	that the Council adopt RESOLUTION NUMBER XXXX, which is the "Resolution Accepting Bid (Award Contract)" for Project Z74: Huron Road/Superior Road Reconstruction Project to R&G Construction Co. of Marshall, Minnesota in the amount of \$787,018.00.

RESOLUTION NUMBER _____, SECOND SERIES

RESOLUTION ACCEPTING BID (AWARD CONTRACT)

WHEREAS, pursuant to an advertisement for bids for Project Z74: Huron Road/Superior Road Reconstruction Project, bids were received, opened and tabulated according to law, and the following bids were received complying with the advertisement for bids:

Bidder	Bid Amount
R&G Construction Co. Marshall, MN	\$787,018.00
D&G Excavating, Inc. Marshall, MN	\$876,785.75
Hulstein Excavating, Inc. Edgerton, MN	\$959,684.00
Duininck, Inc. Prinsburg, MN	\$983,672.50
J.R. Ferche, Inc. Rice, MN	\$1,141,740.75

AND WHEREAS, it appears that R&G Construction Co. of Marshall, Minnesota, is the lowest responsible bidder.

NOW THEREFORE, BE IT RESOLVED BY THE CITY COUNCIL OF MARSHALL, MINNESOTA:

1. The Mayor and City Clerk are hereby authorized and directed to enter into a contract with R&G Construction Co. of Marshall, Minnesota, in the name of the City of Marshall for Project Z74: Huron Road/Superior Road Reconstruction Project, in the amount of \$787,018.00, according to the plans and specifications on file in the office of the City Clerk.

Passed and adopted by the Council this 23rd day of April, 2019.

Mayor

ATTEST:

City Clerk

This Instrument Drafted by:
Glenn J. Olson, P.E.
Director of Public Works/City Engineer



T.H. 59

CSAH 33

SUPERIOR ROAD

SUPERIOR ROAD

Lot 8

Lot 9

HURON ROAD

Not to Scale



CITY ENGINEERS OFFICE
344 WEST MAIN STREET
MARSHALL, MINNESOTA
56258

Z74 Huron & Superior

DATE
1/17/20

Proposed Reconstruction & Utilities

SHEET NO.
1 OF 1



CITY OF MARSHALL AGENDA ITEM REPORT

Meeting Date:	Tuesday, April 23, 2019
Category:	AWARD OF BIDS
Type:	ACTION
Subject:	Consider Bids for Award of Liberty Park Restroom project
Background Information:	Liberty Park currently has no permanent restroom facility. In the Parks Restroom replacement schedule, this park was identified as the 2019 priority for implementing a unit at Liberty. Two proposals were received.
Fiscal Impact:	The purchase of this unit will be funded from Account #401-70276-5520 (Capital-Parks Department-Buildings).
Alternative/ Variations:	Staff requests Council direction on acceptance of at least one of the bids that allows the project to begin and be completed prior to Sounds of Summer in August 2019.
Recommendations:	Staff is confident working with either contractor on said bid presented.

Doom & Cuyper's CONSTRUCTION Inc.

"QUALITY"
A family tradition since 1931.

• 331 Burlington Circle • PO Box 1046, Marshall, MN. 56258 • Phone: 507-532-2101 • Fax: 507-532-3865 • doomcuyper@iw.net

PROPOSAL

PROPOSAL SUBMITTED TO Preston Stensrud PHONE NUMBER (507) 537-6786 ADDRESS, CITY, STATE, ZIP 344 W Main St, Marshall, MN 56258	TODAY'S DATE 3/18/2019 JOB NAME City of Marshall - Liberty Park Restroom JOB LOCATION Liberty Park
---	---

We propose to furnish labor and material necessary to construct a restroom at Liberty Park per the plans and discussions with Preston Stensrud. Any changes that occur during the building department review and permitting process may incur additional costs.

- Bond included
- The contractor will turn the building over broom cleaned
- Final building cleaning by owner
- Seeding and sodding by owner

We propose hereby to furnish material and labor - complete in accordance with above specifications for the sum of:

Seventy-nine thousand two hundred ninety-nine dollars (\$ 79,299.00)

Payment as follows: **Upon competition**

All material is guaranteed to be as specified. All work to be completed in a substantial workmanlike manner according to specifications submitted, per standard practices. Any alteration or deviation from above specifications involving extra costs will be executed only upon written orders, and will become an extra charge over and above the estimate. All agreements contingent upon strikes, accidents or delays beyond our control. Owner to carry fire, tornado and other necessary insurance. Our workers are fully covered by Workmen's Compensation Insurance. If either party commences legal action to enforce its rights pursuant to this agreement, the prevailing party in said legal action shall be entitled to recover its reasonable attorney's fees and costs of litigation relating to said legal action, as determined by a court of competent jurisdiction.

Authorized Signature



Note: this proposal may be withdrawn by us if not accepted within 30 days.

ACCEPTANCE OF PROPOSAL The above prices, specifications and conditions are satisfactory and are hereby accepted. You are authorized to do the work as specified. Payment will be made as outlined above.

Signature _____
Signature _____

Date of Acceptance _____

Preston Stensrud

From: John [john.doomcuyper@iw.net]
Sent: Tuesday, March 19, 2019 4:42 PM
To: Preston Stensrud
Cc: doomcuyper
Subject: RE: Liberty Park Restroom

CITY OF MARSHALL SECURITY NOTICE: This email originated from an external sender. Exercise caution before clicking on any links or attachments and consider whether you know the sender. For more information please contact IT support.

Hi Preston,

No, there isn't any major cost increases between the two projects. However, there wasn't a huge difference between the electrical and mechanical pricing from one project compared to the other. Also, even though the Liberty Park restroom is about half of the size of the Justice Park restroom, we still figured it would take about 65% of the total man hours as it did for the Justice Park restroom.

entry FAN Room Restroom

1/2" = 1'-0"

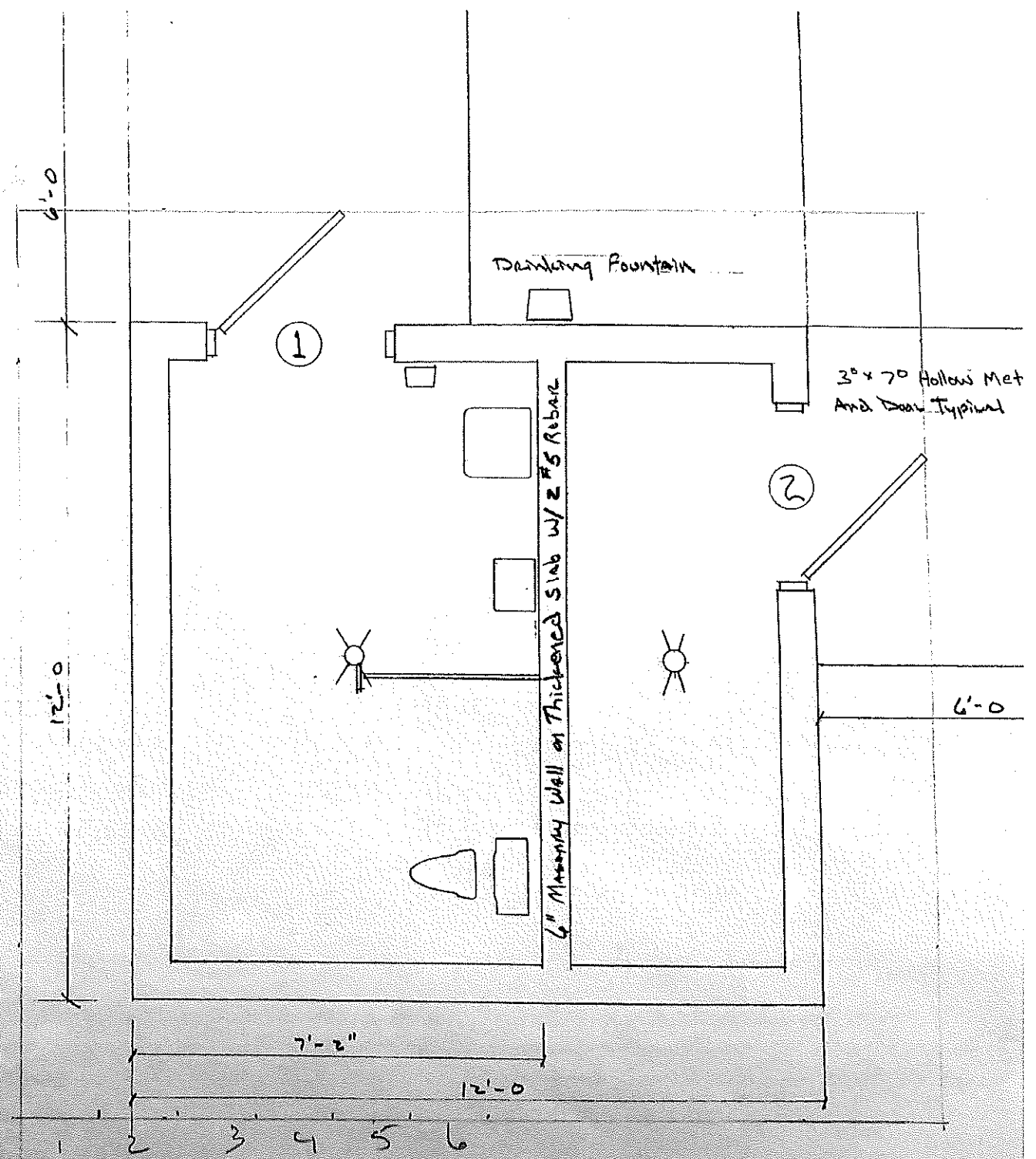

Synthetic Felt
5/8 CDX
Truss System

Root Apron
2x6 Sub Frim

Steel Frim
Alum. Soffit

Sill Seal
2x8 PT Plate
1/2 x 8 Galvanized Acroil Bolt @ 48" On Center AND ALL JOISTS

1/2" AC Plywood, Painted

8" Bond Beam w/2#5 Rebar

Core Fill 4' OR Less w/1#4 Rebar
Core Fill w/1#4 Rebar at Joists and Door Jambos

8" Rock Faced Conc. Block w/Integral Latex
Interior Walls 8" Conc. Block w/ Integral Latex

Interior Walls Sealed

4" 4000# Conc. w/Granite
Sidewalk 6' Wide

8" Bond Beam w/2#5 Rebar

4" 4000# Conc w/Granite

Granular Fill

Granular Fill

City of Marshall, MINNESOTA

Proposal for a Restroom Building at Justice Park in Marshall, Minnesota

Total sum meeting all specs within

\$ 71,540.⁰⁰

Alternate bid for adding 8' of storage onto building and
replace walk in door with 8' wide and 8' tall garage door

\$ NA

We propose to furnish all labor, materials, skill, and equipment in accordance with the "Request for Proposal", "Instructions to Bidders", Specifications, and plans as supplied by the owner for the complete construction of the Restroom Building in Marshall, Minnesota.

In accordance with the advertisement of the Parks Superintendent inviting proposals for a Restroom Building, I hereby certify that I have examined the specifications for the same and I shall meet or exceed the specifications with the above listed bid.

In submitting this bid, the bidder understands that the City reserves the right to reject any or all bids or to waive technicalities and award the bid in the best interest of the City of Marshall.

If awarded a contract, construction will commence on _____, 2019 and be completed by August 1, 2019.

Contractor received addendums – (if any): 1. 2. 3.

.....
Name of firm: BLADHOLM CONSTRUCTIONS INC Date: 4/19/19

Address: 704 WEST COLLEGE DRIVE MARSHALL MN 56258

Signature:  Title: PRESIDENT

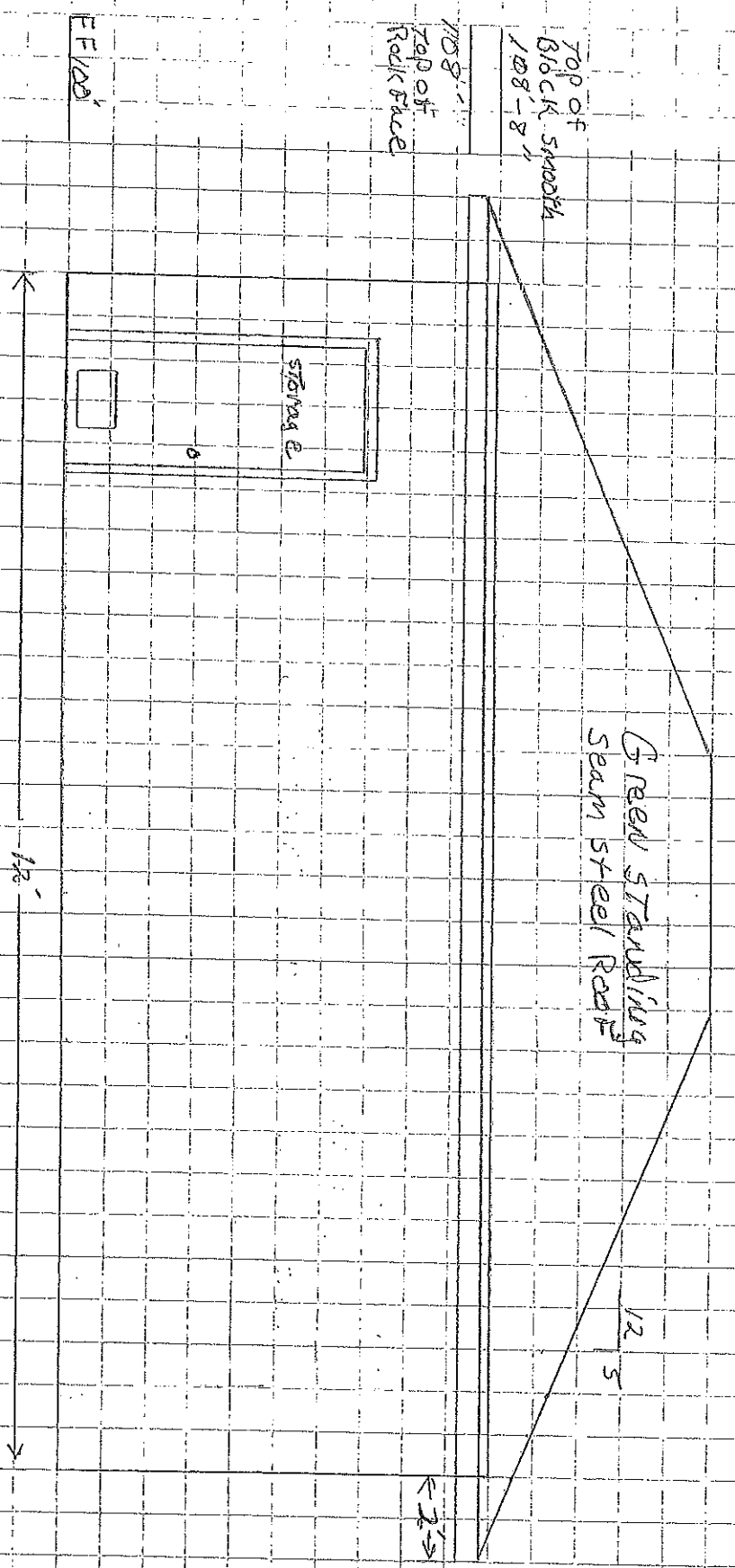

108" = 8"
TOP MASONRY
SMOOTH

10' 8"
TOP ROCK FACE

FF 100

TOP
FOOTING
97

TRANSX
BOTH ROOMS

GREEN STANDING
SEALY 5' 0" RAMP

8" ROCK Faced
Colored Block

8" Block FVN

10" X 12" CONC. FOOTINGS

4" CONC. APRON

12'

6'

INTERIOR Partition walls

108'-8"

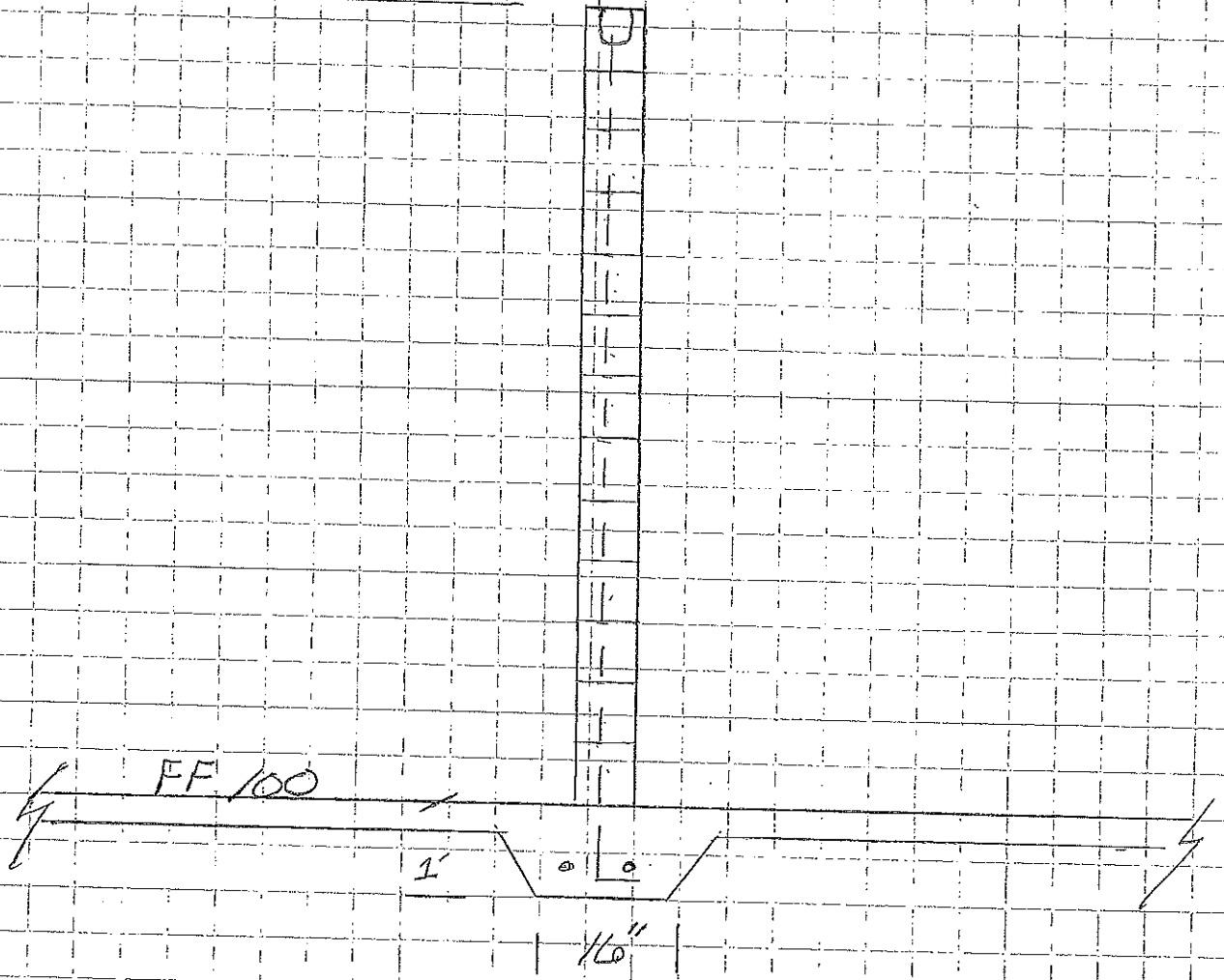

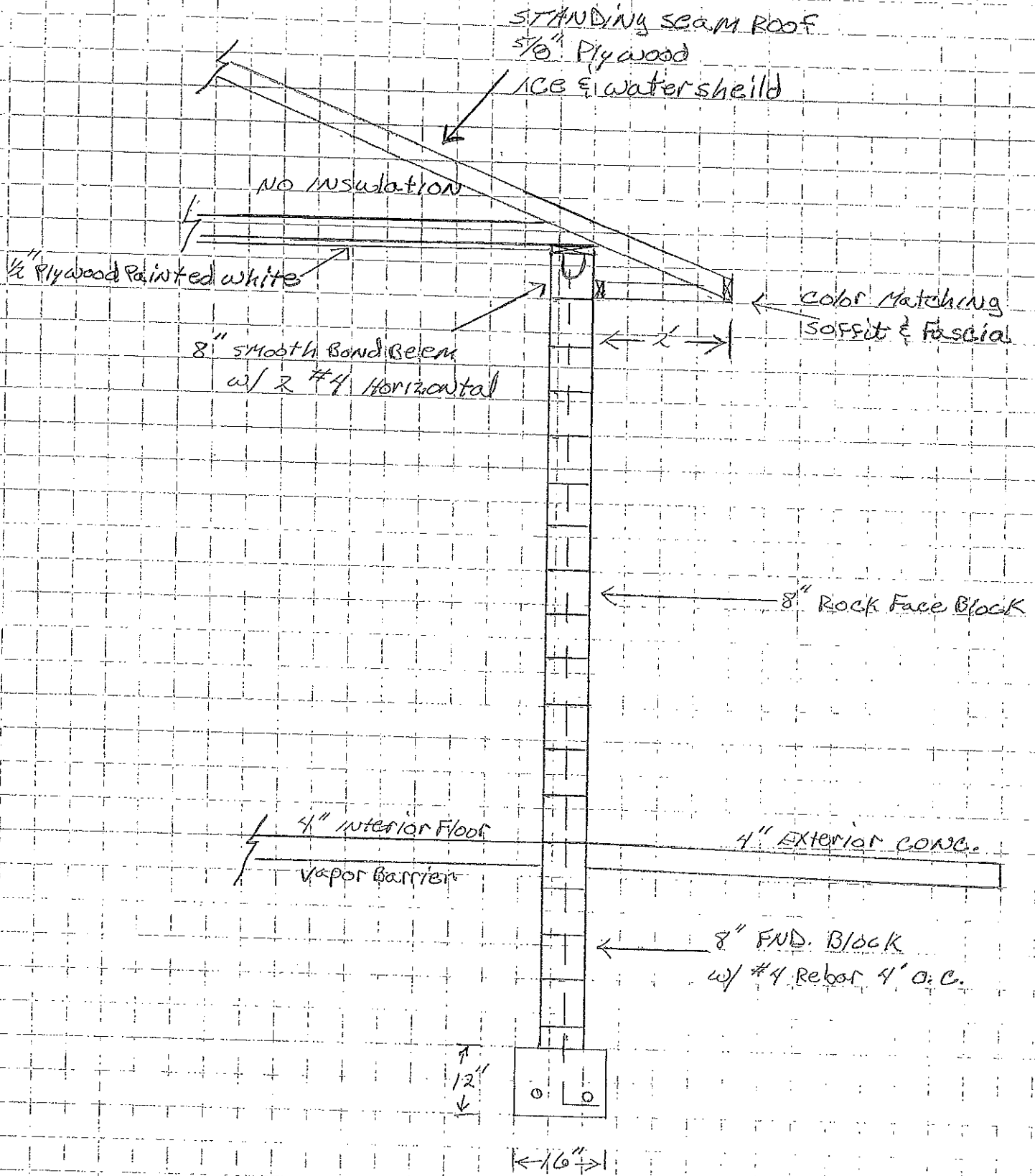

FUND BALANCE POLICY

I. PURPOSE

- A. The purpose of this policy is to establish specific rules the City of Marshall will use to maintain an adequate level of fund balance to provide for cash flow requirements and contingency needs because major revenues, including property taxes and other government aids, are received in the second half of the City's fiscal year.
- B. The purpose of this policy is to also establish specific rules the City of Marshall will use to classify fund balances into categories; based primarily on the extent to which the City is bound to honor constraints on the specific purposes for which amounts in these funds can be spent.

II. CLASSIFICATION OF FUND BALANCE

- A. Non-spendable
 - 1. This category includes fund balance that cannot be spent because it is either (a) not in spendable form or (b) is legally or contractually required to be maintained intact. Examples include inventories and prepaid amounts.
- B. Restricted
 - 1. Fund balance should be reported as restricted when constraints placed on those resources are either (a) externally imposed by creditors, grantors, contributors, or laws or regulations of other governments or (b) imposed by law through constitutional provisions or enabling legislation.
- C. Committed
 - 1. Fund balance that can only be used for specific purposes pursuant to constraints imposed by formal action of the government's highest level of decision-making authority. The committed amounts cannot be used for any other purpose unless the government removes or changes the specified use by taking the same type of action it employed to commit those amounts.
 - 2. The City's highest level of decision making authority (City Council) will, annually or as deemed necessary, commit specific revenue sources for specified purposes by resolution. This formal action must occur prior to the end of the reporting period however, the amount to be subject to the constraint may be determined in the subsequent period.
 - 3. To remove the constraint on specified use of committed resources the City Council shall pass a resolution.

D. Assigned

1. Amounts that are constrained by the government's intent to use for specified purposes, but are neither restricted nor committed. Assigned fund balance in the General fund includes amounts that are intended to be used for specific purposes.
2. The City Council has delegated the authority to assign and remove assignments of fund balance amounts for specified purposes to the Finance Director.

E. Unassigned

1. Unassigned fund balance represents the residual classification for the General fund. It includes amounts that have not been assigned to other funds and that have not been restricted, committed, or assigned to specific purposes within the General fund. The General fund should be the only fund that reports a positive unassigned fund balance amount.
 - a. The City will maintain an unrestricted fund balance in the General fund and the Economic Development special revenue fund of an amount not less than 40% of the next year's budgeted expenditures of the General fund and the Economic Development special revenue fund. This will assist in maintaining an adequate level of fund balance to provide for cash flow requirements and contingency needs because major revenues, including property taxes and other government aids, are received in the second half of the City's fiscal year.
 - b. Fund balance exceeding 40% but less than 50% of the next year's budgeted General fund expenditures shall remain as an unassigned fund balance.
 - c. Fund balance in excess of 50% shall be reviewed by City Council to determine if such excess should be transferred to other funds to be used as a financing source for capital improvement, equipment purchases, or other needs as determined by City Council.
 - d. If spending unrestricted fund balance in designated circumstances has reduced unrestricted fund balance to a point below the minimum targeted level, as noted above, the replenishment will be funded by revenue and/or expenditure adjustments within the next year's budgeting process.

III. DESIGNATION OF ENTERPRISE FUNDS

1. It is the goal of each enterprise fund to cover the costs of operations, including depreciation and a transfer to the General fund, to maintain a financially healthy enterprise. The City will maintain cash reserves in the Enterprise funds at a minimum level equal to 25% of the annual operating costs plus one year of debt service payments
 - a. The Liquor fund shall be exempt from this provision since the majority of the profits are transferred to the General fund
 - b. The waste water fund in addition shall reserve 1/3 depreciation of all assets annually to fund future improvements. The City Council shall

determine the use of these reserves.

2. If the cash reserve balance falls below the minimum target level, the replenishment will be funded by revenue and/or expense adjustments within the next year's budgeting process

IV. STABILIZATION ARRANGEMENTS

- A. Stabilization arrangements are defined as formally setting aside amounts for use in emergency situations or when revenue shortages or budgetary imbalances arise.
- B. The City will set aside amounts by resolution as deemed necessary that can only be expended when certain specific circumstances exist. The resolution will identify and describe the specific circumstances under which a need for stabilization arises. The need for stabilization will only be utilized for situations that are not expected to occur routinely.

V. MONITORING AND REPORTING

- A. The City Administrator and Director of Administrative Services shall annually prepare the status of fund balances in relation to this policy and present to the City Council in conjunction with the annual audit.
- B. When both restricted and unrestricted resources are available for use, it is the City's policy to first use restricted resources, and then use unrestricted resources as they are needed.
- C. When committed, assigned or unassigned resources are available for use, it is the City's policy to use resources in the following order: 1.) committed 2.) assigned and 3.) unassigned.
- D. A negative residual amount may not be reported for restricted, committed, or assigned fund balances in the General fund.

Passed and adopted by the Common Council this 9th day of April , 2019.

THE COMMON COUNCIL

ATTEST:

Mayor of the City of Marshall, MN

City Clerk

I. PURPOSE

- A. The purpose of this policy is to establish specific rules the City of Marshall will use to maintain an adequate level of fund balance to provide for cash flow requirements and contingency needs because major revenues, including property taxes and other government aids, are received in the second half of the City's fiscal year.
- B. The purpose of this policy is to also establish specific rules the City of Marshall will use to classify fund balances into categories; based primarily on the extent to which the City is bound to honor constraints on the specific purposes for which amounts in these funds can be spent.

II. CLASSIFICATION OF FUND BALANCE

- A. Non-spendable
 - 1. This category includes fund balance that cannot be spent because it is either (a) not in spendable form or (b) is legally or contractually required to be maintained intact. Examples include inventories and prepaid amounts.
- B. Restricted
 - 1. Fund balance should be reported as restricted when constraints placed on those resources are either (a) externally imposed by creditors, grantors, contributors, or laws or regulations of other governments or (b) imposed by law through constitutional provisions or enabling legislation.
- C. Committed
 - 1. Fund balance that can only be used for specific purposes pursuant to constraints imposed by formal action of the government's highest level of decision-making authority. The committed amounts cannot be used for any other purpose unless the government removes or changes the specified use by taking the same type of action it employed to commit those amounts.
 - 2. The City's highest level of decision making authority (City Council) will, annually or as deemed necessary, commit specific revenue sources for specified purposes by resolution. This formal action must occur prior to the end of the reporting period however, the amount to be subject to the constraint may be determined in the subsequent period.

3. To remove the constraint on specified use of committed resources the City Council shall pass a resolution.

D. Assigned

1. Amounts that are constrained by the government's intent to use for specified purposes, but are neither restricted nor committed. Assigned fund balance in the General fund includes amounts that are intended to be used for specific purposes.
2. The City Council has delegated the authority to assign and remove assignments of fund balance amounts for specified purposes to the Finance Director.

E. Unassigned

1. Unassigned fund balance represents the residual classification for the General fund. It includes amounts that have not been assigned to other funds and that have not been restricted, committed, or assigned to specific purposes within the General fund. The General fund should be the only fund that reports a positive unassigned fund balance amount.

a. The City will maintain an unrestricted fund balance in the General fund and the Economic Development special revenue fund of an amount not less than ~~5~~ 40% of the next year's budgeted expenditures of the General fund and the Economic Development special revenue fund. This will assist in maintaining an adequate level of fund balance to provide for cash flow requirements and contingency needs because major revenues, including property taxes and other government aids, are received in the second half of the City's fiscal year.

b. Fund balance exceeding 40% but less than 50% of the next year's budgeted General fund expenditures shall remain as an unassigned fund balance.

~~a.c.~~ Fund balance in excess of 50% shall be reviewed by City Council to determine if such excess should be transferred to other funds to be used as a financing source for capital improvement, equipment purchases, or other needs as determined by City Council.

~~b.~~ The City will maintain an unrestricted fund balance for emergency or unanticipated expenditures in the General fund of an amount not less than 1-month of the next year's budgeted expenditures of the General fund.

~~e.~~ According to the Governmental Accounting Standards Board (GASB) Statement 45, the City of Marshall is required to have an actuarial valuation of the City's Other Post Employment Benefits (OPEBs) completed every two years. This actuarial valuation considers post retirement medical, dental and life insurance and also severance pay including accrued vacation and sick leave. Based upon the benefits and census information, the actuarial valuation is computed for the City's annual contribution for two years, which shall be maintained as an unrestricted fund balance in each respective City fund.

If spending unrestricted fund balance in designated circumstances has reduced unrestricted fund balance to a point below the minimum targeted level, as noted above, the replenishment will be funded by revenue and/or expenditure adjustments within the next year's budgeting process.

d.

~~III.~~ DESIGNATION OF ENTERPRISE FUNDS ~~NET ASSETS~~

III.

~~1. The City will maintain a restricted net asset balance in the Enterprise funds of an amount not less than 25% of the next year's budgeted expenditures of each individual Enterprise fund. This will assist in maintaining an adequate level of funds for cash flow requirements and contingency.~~

1. It is the goal of each enterprise fund to cover the costs of operations, including depreciation and a transfer to the General fund, to maintain a financially healthy enterprise. The City will maintain cash reserves in the Enterprise funds at a minimum level equal to 25% of the annual operating costs plus one year of debt service payments

a. The Liquor fund shall be exempt from this provision since the majority of the profits are transferred to the General fund

b. The waste water fund in addition shall reserve 1/3 depreciation of all assets annually to fund future improvements. The City Council shall determine the use of these reserves.

2. If the cash reserve balance falls below the minimum target level, the replenishment will be funded by revenue and/or expense adjustments within the next year's budgeting process

IV. STABILIZATION ARRANGEMENTS

~~A.~~ Stabilization arrangements are defined as formally setting aside amounts for use in emergency situations or when revenue shortages or budgetary imbalances arise.

A.

B. The City will set aside amounts by resolution as deemed necessary that can only be expended when certain specific circumstances exist. The resolution will identify and describe the specific circumstances under which a need for stabilization arises. The need for stabilization will only be utilized for situations that are not expected to occur routinely.

V. MONITORING AND REPORTING

A. The City Administrator and Director of Administrative Services ~~City Clerk~~ shall annually prepare the status of fund balances in relation to this policy and present to the City Council in conjunction with the annual audit.

B. When both restricted and unrestricted resources are available for use, it is the City's policy to first use restricted resources, and then use unrestricted resources

- as they are needed.
- C. When committed, assigned or unassigned resources are available for use, it is the City's policy to use resources in the following order: 1.) committed 2.) assigned and 3.) unassigned.
 - D. A negative residual amount may not be reported for restricted, committed, or assigned fund balances in the General fund.

Passed and adopted by the Common Council this ~~26.9~~²⁶th day of ~~April~~^{June}, 201~~92~~²².

THE COMMON COUNCIL

ATTEST:

Mayor of the City of Marshall, MN

City Clerk



CITY OF MARSHALL AGENDA ITEM REPORT

Meeting Date:	Tuesday, April 23, 2019
Category:	CONSENT AGENDA
Type:	ACTION
Subject:	Consider Amendments to the Fund Balance Policy
Background Information:	<p>Staff propose amendments to the Fund Balance Policy. During the long-term financial plan study conducted by AEM, it was recommended to reduce the City’s fund balance policy from 50 to 40 percent of next year’s budgeted expenditures to start funding capital improvements using cash instead of bonding.</p> <p>Information was gathered from 4 of Marshall’s comparable cities on what their fund balance policy states. The fund balance policies ranged from 30 to 60 percent.</p> <p>The Office of the State Auditor’s Office recommends unrestricted fund balances of approximately 35 to 50 percent.</p> <p>With this fund balance policy change, the City can begin to finance capital improvement projects using available cash and avoid interest and fees associated with bonding.</p>
Fiscal Impact:	
Alternative/ Variations:	
Recommendations:	Approve General Fund Balance from 50% and a month to 40% and refer to Ways and Means Committee to Finalize the complete Fund Balance Policy for Council Approval at Future Council Meeting.



CITY OF MARSHALL AGENDA ITEM REPORT

Meeting Date:	Tuesday, April 23, 2019
Category:	CONSENT AGENDA
Type:	ACTION
Subject:	Consider Approval of Amendments to Interfund Loan Resolution for TIF 1-5 for Marshall Hotel Project
Background Information:	<p>On February 28, 2017 City Council adopted resolution 4355 allowing an interfund loan from TIF District 1-11 to cover expenses related to infrastructure improvements for the Marshall Hotel Acquisition & Redevelopment up to \$350,000.</p> <p>On February 26, 2019 City Council awarded a bid for removal of hazardous materials and miscellaneous debris in the amount of 72,468.53 for the Marshall Hotel. This amount along with the acquisition costs for the Marshall Hotel exceeds the \$350,000 maximum.</p> <p>The proposed resolution amendments align the resolution and the redevelopment plan's authorized expenses for the Marshall Hotel Project. Previous resolutions reference TIF District 1-11 but the authority is within TIF District 1-5's Redevelopment Plan.</p>
Fiscal Impact:	
Alternative/ Variations:	
Recommendations:	Approve Amendments to Interfund Loan Resolution for TIF 1-5 for Marshall Hotel Project

RESOLUTION NO. _____, SECOND SERIES

RESOLUTION AMENDING RESOLUTION 4355
APPROVING THE TERMS OF UP TO A
\$500,000 INTERFUND LOAN IN CONNECTION WITH
TAX INCREMENT FINANCING (REDEVELOPMENT) DISTRICT
NO. 1-5

BE IT RESOLVED by the City Council (the "Council") of the City of Marshall, Minnesota (the "City"), as follows:

Section 1. Background.

(a) The City has heretofore approved the establishment of Tax Increment Financing Redevelopment District No. 1-5 (the "TIF District") within Redevelopment Project No. 1, and has adopted a tax increment financing plan for the TIF District (the "TIF Plan").

(b) The City has determined to pay for certain costs identified in the TIF Plan related to the infrastructure improvements for the Marshall Hotel Acquisition & Redevelopment (the "Qualified Costs"), which costs may be financed on a temporary basis from City funds available for such purposes.

(c) Under Minnesota Statutes, Section 469.198, Subd. 7, the City is authorized to advance or loan money from the City's general fund or any other fund from which such advances may be legally made, including tax increments from tax increment financing districts (collectively, the "Fund"), in order to finance the Qualified Costs.

(d) The City intends to reimburse itself for the payment of the Qualified Costs, plus interest thereon, from tax increments derived from the TIF District in accordance with the terms of this resolution (which terms are referred to collectively as the "Interfund Loan").

(e) On February 28, 2017, the City Council had approved a Resolution Approving the Terms of Up to a \$350,000 Interfund Loan in Connection with Tax Increment Financing (Redevelopment) District No.1-11 with a term that included an advance up to \$350,000 from the Fund.

(f) The City has determined that additional expenses are deemed necessary and would like to establish a new advance maximum of up to \$500,000 from the fund with all other terms of interfund loan remaining the same.

Section 2. Terms of Interfund Loan.

(a) The City hereby authorizes the advance of up to \$500,000 from the Fund or so much thereof as may be paid as Qualified Costs. The City shall reimburse itself for such advances together with interest at the rate stated below. Interest accrues on the

principal amount from the date of each advance. The maximum rate of interest permitted to be charged is limited to the greater of the rates specified under Minnesota Statutes, Section 270C.40 or Section 549.09 as of the date the loan or advance is authorized, unless the written agreement states that the maximum interest rate will fluctuate as the interest rates specified under Minnesota Statutes, Section 270C.40 or Section 549.09 are from time to time adjusted. The interest rate shall be 0.00% and will not fluctuate.

(b) Principal and interest on the Interfund Loan shall be paid semi-annually on each February 1 and August 1 (each a "Payment Date") commencing with the Payment Date on which the City has Available Tax Increment (defined below), or on any other dates determined by the City Finance Director, through the last receipt of tax increment from the TIF District.

(c) Payments on the Interfund Loan are payable solely from "Available Tax Increments" which shall mean, on each Payment Date, all of the tax increment available after other obligations have been paid, generated in the preceding six (6) months with respect to the property within the TIF District and remitted to the City by Lyon County, all in accordance with Minnesota Statutes, Sections 469.194 to 469.1999. Payments on the Interfund Loan are subordinate to any outstanding or future bonds, notes or contracts secured in whole or in part with Available Tax Increment, and are on parity with any other outstanding or future interfund loans secured in whole or in part with Available Tax Increment.

(d) The principal sum and all accrued interest payable under the Interfund Loan are pre-payable in whole or in part at any time by the City without premium or penalty. No partial prepayment shall affect the amount or timing of any other regular payment otherwise required to be made under this Interfund Loan.

(e) The Interfund Loan is evidence of an internal borrowing by the City in accordance with Minnesota Statutes, Section 469.198, Subd. 7, and is a limited obligation payable solely from Available Tax Increment pledged to the payment hereof under this resolution. The Interfund Loan and the interest hereon shall not be deemed to constitute a general obligation of the State of Minnesota or any political subdivision thereof, including, without limitation, the City. Neither the State of Minnesota, nor any political subdivision thereof shall be obligated to pay the principal of or interest on the Interfund Loan or other costs incident hereto except out of Available Tax Increment, and neither the full faith and credit nor the taxing power of the State of Minnesota or any political subdivision thereof is pledged to the payment of the principal of or interest on the Interfund Loan or other costs incident hereto. The City shall have no obligation to pay any principal amount of the Interfund Loan or accrued interest thereon, which may remain unpaid after the termination of the TIF District.

(f) The City may amend the terms of the Interfund Loan at any time by resolution of the City Council, including a determination to forgive the outstanding principal amount and accrued interest to the extent permissible under law.

Section 3. Effective Date. This resolution is effective upon the date of its approval.

Adopted this 23th day of April 2019.

Robert J. Byrnes
Mayor

ATTEST:

Kyle Box
City Clerk



CITY OF MARSHALL AGENDA ITEM REPORT

Meeting Date:	Tuesday, April 23, 2019
Category:	CONSENT AGENDA
Type:	ACTION
Subject:	Consider approval of a Refuse Haulers License for West Central Sanitation, INC. of Willmar, MN.
Background Information:	Attached is a copy of the application for Refuse Haulers for West Central Sanitation, INC. This application has been reviewed and met the necessary requirements.
Fiscal Impact:	\$160.00
Alternative/ Variations:	Not to approve this license.
Recommendations:	the approval of the Refuse Haulers License for West Central Sanitation Inc., for the period April 24, 2019 through March 31, 2020 at a fee of \$160.00

GARBAGE/REFUSE HAULERS LICENSE APPLICATION FORM

City of Marshall ~ 344 West Main Street ~ Marshall MN 56258
Phone (507) 537-6763 ~ Fax (507) 537-6830

ANNUAL FEE: \$160.00 (ATTACH TO APPLICATION) Receipt No. _____

LICENSE PERIOD FROM APRIL 1, 2018 TO MARCH 31, 2019

TO COMPLY WITH THE CITY CODE OF THE CITY OF MARSHALL, MINNESOTA,
REGULATING THE LICENSING OF REFUSE HAULERS



NAME OF APPLICANT:

Don Keith Williamson
(First) (Full Middle) (Last)

HOME ADDRESS:

Box 796
(RR, P.O. Box or Street)
Willmar MN 56201
(City) (State) (Zip Code)

BUSINESS NAME:

West Central Sanitation Inc.

BUSINESS ADDRESS:

PO Box 796
(RR, P.O. Box or Street)
Willmar MN 56201
(City) (State) (Zip Code)

PHONE NUMBER:

() () () (320) 235-7630
(Home) (Business)

REFERENCES:

- 1) Teather Bliss city Clerk Cottonwood MN
(Name)
PO Box 106 Cottonwood MN 56229
(Address)
- 2) Jer Javens Harrison Truck Centers
(Name)
1501 North Hwy 59 Marshall MN 56258
(Address)

VEHICLE INSURANCE POLICY:
(Certificate required)

Jim Enge. SECURA INSURANCE
(Name of Agent) (Name of Company)
4.30.18 - 4.30.19 1,000,000
(Period of Coverage) (Amount of Coverage)
Any Auto Comp / Coll
(Type of Coverage)

Endorsement must provide that said policy shall not be cancelled or terminated without at least ten (10) days notice in writing to the City.

VEHICLES:

Applicant hereby certifies that they have tight packer type vehicles in good condition to prevent loss in transit of liquid or solid cargo, and that the vehicles will be kept clean and free of offensive odors, and will not stand on any street longer than reasonable necessary to collect the garage or refuse.

TYPE OF LICENSE:

Garbage and/or Refuse (check applicable license type)

TYPE OF EMPLOYMENT:

Owner and/or Operator (check applicable license type)

"All items removed by the contractor shall be disposed of in the Lyon County Landfill and in accordance with the Lyon County solid waste plan and Lyon County ordinances."

Signature of Applicant

Don Williamson
President 4/9/19

Date

4-1-19



CITY OF MARSHALL AGENDA ITEM REPORT

Meeting Date:	Tuesday, April 23, 2019
Category:	CONSENT AGENDA
Type:	ACTION
Subject:	Consider approval of Transient Merchant License for Frankie's Hot Dogs, LLC
Background Information:	Frankie's Hot Dogs, LLC is seeking approval of a transient merchant license. If approved this license would expire on 12/31/19.
Fiscal Impact:	\$315.00 plus a \$5,000 insurance bond.
Alternative/ Variations:	Not to approve this license.
Recommendations:	the approval of a Transient Merchant License for Frankie's Hot Dogs, LLC, to operate a mobile food unit in Marshall from May 1, 2019 through December 31, 2019 contingent upon all requirements being completed at a fee of \$210.00.

APPLICATION FOR TRANSIENT MERCHANT LICENSE
CITY OF MARSHALL, MINNESOTA
THROUGH 12/31/19

Due With Application: Minimum Bond Requirement: \$5,000 and License Fee: \$315 Receipt # _____

1) Name of Applicant Kisner Sarah E
Last First Middle
Address of Applicant 2614 State Hwy 23 Marshall MN 56258
Street City State Zip Code
Phone Number: 563-357-4098
Date of Birth of Applicant 1-78 Social Security Number _____
Drivers License Number _____ MN
Number State
Name of Business (Trade Name) Frankie's Hot Dogs, L.L.C.
Address 2614 State Hwy 23 Marshall MN 56258
(Street) (City) (State) (Zip Code)
Phone Number (563) 357-4098

2) Person(s) to be employed in municipality during the period for which application is made:

a) Kisner Sarah E
Last First Middle Date of Birth Social Security No.
2614 State Hwy 23 Marshall MN 56258
Drivers License Number Street City State Zip Code
b) Kisner Chad M
Last First Middle Date of Birth Social Security No.
2614 State Hwy 23 Marshall MN 56258
Drivers License Number Street City State Zip Code

If additional employees, list on separate sheet of paper.

3) Description of Business Mobile Food Cart Vendor selling hot dogs, variety of condiments, chips, soda/water - as approved by Health Dept.
Methods of soliciting mobile food cart, trailered by a vehicle
Goods to be sold hot dogs and above mentioned foods; vendor merch (t-shirts-hats)
Dates of Soliciting Monday - Sunday; Spring - Fall

4) Place or places in Marshall where applicant will be engaging in their business.

- various businesses
- private property to include local business as permission is granted
- public streets as permitted

5) License number or numbers of vehicles transporting applicants and their goods:

a) _____ MN _____ c) _____
 Number State Number State

b) _____ MN _____ d) _____
 Number State Number State

6) References - including at least one bank or lending institution:

a) MinnWest Bank _____ 507/929-6012 _____
 Name (If person give First, Middle and Last Name) Telephone Number

301 Baseline Rd _____ Marshall MN 56258 _____
 Street City State Zip Code

b) Pastor Doug Wing _____ 605/212-2810 _____
 Name (If person give First, Middle and Last Name) Telephone Number

2259 CR25 _____ Lynd MN 56157 _____
 Street City State Zip Code

c) Regina Clare Meulebroeck _____ 507/828-9569 _____
 Name (If person give First, Middle and Last Name) Telephone Number

417 N 3rd Street _____ Marshall MN 56258 _____
 Street City State Zip Code

7) List 3 municipalities in which applicant has conducted business in the past 12 months:

a) n/a _____
 City State

b) _____
 City State

c) _____
 City State

COMMENTS: _____

Payment
 Due With
 Application

TITLE OF APPLICANT: Owner/Operator
 SIGNATURE OF APPLICANT: [Signature]

Received by the City Clerk on this 5 day of April, 20 19

Signature of the City Clerk [Signature]

REPORT OF DIRECTOR OF PUBLIC SAFETY: _____

 DIRECTOR OF PUBLIC SAFETY



April 23, 2019

Frankie's Hot Dogs, L.L.C.
Chad & Sarah Kisner
2614 St Hwy 23
Marshall, MN 56258

To Members of the Marshall City Council:

This evening you will be considering approval of the Transient Merchant License for Frankie's Hot Dogs, L.L.C. We ask that you also consider approval of a reduced License Fee for the year 2019. The current fee for the year is \$315 or \$26.25 per month. We will begin operation May 1, 2019, and continue through December 31, 2019, weather permitting. The total number of months of operation is 8; thus, we ask our License Fee to be \$210.00 for the year.

Thank you for your time and consideration.

Very truly yours,

Chad & Sarah Kisner



CITY OF MARSHALL AGENDA ITEM REPORT

Meeting Date:	Tuesday, April 23, 2019
Category:	CONSENT AGENDA
Type:	ACTION
Subject:	Consider authorization to declare vehicles as surplus property for the Marshall Police Department.
Background Information:	These vehicles have been abandoned or seized by the Marshall Police Department and have gone through the notification processes and required periods for disposal.
Fiscal Impact:	These vehicles will be auctioned on-line at the state site or will be taken to Alters for disposal.
Alternative/ Variations:	
Recommendations:	That the vehicles be declared as surplus property by the City of Marshall.

19-3332	03 Ford F150	880 UNL	2FTRX18L13CA39216	Abandoned	PD	No Keys	General
19-1832	99 Chevy Malibu	BMH 909	1G1ND52M1XY154860	Abandoned	PD	LEC	General
18-21622	99 Lexus	HRK6303 TX	JT6GF10O0X0042093	Abandoned	PD	No Keys	General
19-2501	99 Dodge Stratus	496 VVC	1B3EJ46X3XN671708	Abandoned	Pulvers	No Keys	General
19-1673	99 Ford Explorer	067 LEY	1FMZU34X8XZB12681	Abandoned	PD	No Keys	General
19-2060	00 Toyota Camry	494 VVC	4T1BG22K7YU757024	Abandoned	Pulvers	In Car	General

18-13734	13 Dodge Ram	359 MUB	1C6RR7NT8DS500255	Forf (City Atty)
18-3946	03 Honda Civic	434 WVM	2HGE5161X3H604324	Forf (City Atty)
18-7582	99 Mercedes Benz	FL 2303XP	4JGAB54E9XA070551	Forf (City Atty)
18-8657	02 Ford Taurus	852 UNL	1FAFP55U62G240460	Forf (City Atty)
18-10390	00 Pont Grand Prix	311 TXV	1G2WP52K6TF348254	Forf (City Atty)



CITY OF MARSHALL AGENDA ITEM REPORT

Meeting Date:	Tuesday, April 23, 2019
Category:	CONSENT AGENDA
Type:	ACTION
Subject:	Commerce Industrial Park Farm Lease - 2019.
Background Information:	<p>Attached please find the proposed \$0.00 cost farm lease for Commerce Industrial Park for 2019.</p> <p>The City had previously requested leases for a five-year period of time beginning in 2019. Only one bid was received and did not cover the potential taxes that would be due on the property because of the rental. It was decided not to enter into the lease agreement. The City was to provide weed control for the season of 2019 and would readvertise for farm lease for the property in the fall of 2019 for the future years 2020-2023.</p> <p>In lieu of having the expenses for tillage and seeding and weed control for 2019, the City negotiated with the sole bidder on the 2019 lease RJC, Inc. (Richard Carrow) to enter into a \$0.00 cost farm lease in exchange for RJC, Inc. providing all weed control for the 2019 season.</p>
Fiscal Impact:	None.
Alternative/ Variations:	No alternative actions recommended.
Recommendations:	That the City Council approve the \$0.00 cost farm lease for Commerce Industrial Park with RJC, Inc. (Richard Carrow) for 2019.

FARM LEASE

THIS AGREEMENT, Made this 23rd day of April, 2019, by and between the City of Marshall, a municipal corporation, Lessor, and RJC, Inc., of the County of Lyon, State of Minnesota, Lessee.

WITNESSETH, That the said Lessor, in consideration of the rents and covenants hereinafter mentioned, does hereby Remise, Lease and Let unto the said Lessee, and the said Lessee does hereby hire and take from the said Lessor, the following described premises situated in the County of Lyon, State of Minnesota, to-wit:

Parcel 12: 127.7 +/- acres of farm land in the as described and shown on the attached map, a copy of which is attached and made a part of this Agreement.

To Have and to Hold, the above rented premises unto the said Lessee, their heirs and assigns, subject to the conditions and limitations hereinafter mentioned for and during the term of this lease ending the 15th day of October, 2019.

And the said Lessee agrees to and with the said Lessor to pay as rent for the above-mentioned premises, for and during the full term of this lease, rent as follows:

2019	127.7 acres +/-	\$0.00/acre	\$0.00 due
------	-----------------	-------------	------------

And it is Further Agreed, By and between the parties as follows:

Lessee shall maintain positive weed control on land being rented, including adjacent township roadways, at their own expense.

Lessee shall furnish all materials necessary for crop production at their own expense.

Any subsequent Lessees shall have access to said premises. After current Lessee has finished with fall harvest which includes removal of crops and crop residue (residue to be removed within two weeks of crop removal), so as to allow for fall application of chemicals, if subsequent Lessee desires to apply fall chemicals.

Animal manure, if applied, must be incorporated into the soil within eight (8) hours of application. If not incorporated within said eight (8) hours, City reserves right to terminate lease and charge Lessee the cost of said incorporation.

Equipment, bales and crop products shall not be stored or remain on the site for more than five (5) days.

And the said Lessee also covenants and agrees to and with the said Lessor, not to assign this Lease or underlet the above-rented premises or any part thereof, and that he will, at the expiration of the time as herein recited, quietly yield and surrender the aforesaid premises to the said Lessor, in as good condition and repair as when taken, reasonable wear and tear and damage by the elements alone excepted. Said Lessee also covenants and agrees to cultivate the hereby leased premises in a careful and husband-like manner, and to commit no waste or damage on said real estate and to suffer none to be done.

The Lessee is also to destroy all Russian Thistles and other noxious weeds growing on said land, declared by statute to be common nuisances, within the times prescribed by law, and shall keep all roadways (Pacific Avenue) and other parts of the land, not in crop, mowed and free from growing weeds. And the Lessor or its agent shall have the right to enter upon said premises at any time, without injury to the standing crops, for the purpose of making any improvements, or for any other purpose whatsoever.

City of Marshall, Lessor reserves the right to develop all or part of the above described premises for commercial or industrial purposes. If some or all of the land is developed, the Lessor shall attempt to do the development so as to minimize damage done to current year's crops. However, if crops are damaged, the Lessor shall reimburse Lessee for crop damage.

And the said Lessor covenants that the said Lessee, performing the covenants aforesaid, shall peaceably and quietly have, hold and enjoy the said rented premises.

Lessee has no right to an extension of this Lease.

The Lessee for 2020 shall be responsible for fall "plow back".

IN WITNESS WHEREOF, We have hereunto set our hands the day and year first above written.

LESSEE
RJC, Inc.

LESSOR
CITY OF MARSHALL

By: _____
Richard J. Carrow

By: _____
Mayor

Its: President

By: _____
City Administrator

By: _____
City Clerk

STATE OF MINNESOTA)
)ss
COUNTY OF LYON)

On this ____ day of _____, 2019, before me, a notary public within and for said County and State, personally appeared _____, Lessee.

Notary Public

STATE OF MINNESOTA)
)ss
COUNTY OF LYON)

On this ____ day of _____, 2019, before me, a notary public within and for said County and State, personally appeared Robert J. Byrnes, Mayor; Sharon Hanson, City Administrator; and Kyle Box, City Clerk of the City of Marshall, a municipal corporation, on behalf of the municipality, to me known to be the persons described in and who executed the foregoing instrument, and acknowledged that they executed the same as their free act and deed.

Notary Public

This Instrument Drafted by:
QUARNSTROM & DOERING, P.A.
By: Dennis H. Simpson, Marshall City Attorney
109 South Fourth Street
Marshall, MN 56258
(507)537-1441



PARCEL 12
64.1 ACRES ±

PARCEL 12
34.4 ACRES ±

PARCEL 12
29.2 ACRES ±

Not To Scale



CITY ENGINEERS OFFICE
344 WEST MAIN STREET
MARSHALL, MINNESOTA
56258

127.7 TOTAL ACRES ±

DATE
10/08/18

Farm Lease
Parcel # 12

SHEET 54
1 OF 1



CITY OF MARSHALL AGENDA ITEM REPORT

Meeting Date:	Tuesday, April 23, 2019
Category:	CONSENT AGENDA
Type:	ACTION
Subject:	Authorization of acceptance of a HMEP Grant for the Southwest Chemical Assessment Team and to authorize the Director of Public Safety/Police Chief Jim Marshall to administer the grant.
Background Information:	<p>The Southwest Minnesota Chemical Assessment Team (CAT) is the hazardous materials response team for both the City of Marshall and the 14 counties of West-Central and South-West Minnesota. The team is funded through a state funded grant which requires local match funds.</p> <p>Hazardous materials spills are fortunately rare events, but when they do occur require a rapid response and the CAT's exist as regional teams to support and supplement local fire departments within their region. It takes a lot of training to have individuals who are capable to respond in this critical role.</p> <p>The City of Marshall has been awarded funds to supplement these operating grant funds for the training of CAT members. This grant will fund having team members receive the advanced training that is available through the annual hazardous materials conference called the Cold Zone that is located in North Minneapolis.</p> <p>There is a financial match requirement for this grant, but that match will come from the Team's operating grant and not local general funds. A copy of the Grant Agreement and budget as well as information on Signatory Requirements of the grant are attached. A resolution authorizing Director of Public Safety/Police Chief Jim Marshall to administer the grant is also attached.</p>
Fiscal Impact:	The grant is for \$4,935.00, with a cash match requirement of \$1,233.75 for a total budget of \$6,168.75.
Alternative/Variations:	None
Recommendations:	Authorization of acceptance of a HMEP Grant for the Southwest Chemical Assessment Team and to authorize the Director of Public Safety/Police Chief Jim Marshall to administer the grant.

RESOLUTION NUMBER _____, SECOND SERIES

RESOLUTION AUTHORIZING ACCEPTANCE OF A 2019 HAZARDOUS MATERIALS EMERGENCY PREPAREDNESS GRANT

WHEREAS, the City of Marshall's Southwest Minnesota Chemical Assessment Team (SWMN CAT) desires to protect the health of its citizens and the citizens of the Southwest and West-Central regions of Minnesota; and

WHEREAS, under Minn. Stat. ss 299A.01, Sbd. 2 (4) the State of Minnesota is empowered to enter into this grant agreement, the Minnesota Department of Public Safety, Homeland Security and Emergency Management Division has funding to promote hazardous materials emergency preparedness; and

WHEREAS, the Minnesota Department of Public Safety, Homeland Security and Emergency Management Division has agreed to provide funding to supplement the training of the members of the Southwest Minnesota Chemical Assessment Team to maintain and improve its proficiency in hazardous materials response by providing additional funding for the department;

BE IT RESOLVED, that the City of Marshall entered into an agreement with the Minnesota Department of Public Safety, Homeland Security and Emergency Management Division for the period from March 27, 2019 or once the state has obtained all required signatures to September 30, 2019.

BE IT RESOLVED, that the Mayor of the City of Marshall and City Clerk of the City of Marshall, are hereby authorized to execute such agreements as are necessary to implement the project on behalf of the City of Marshall.

BE IT FURTHER RESOLVED, that the Director of Public Safety/Chief of Police is authorized to administer the grant.

Passed and adopted by the Council the 23rd day of April 2019.

THE COMMON COUNCIL

Mayor of the City of Marshall, MN

ATTEST:

City Clerk



Minnesota Department of Public Safety (“State”) Homeland Security and Emergency Management Division 445 Minnesota Street, Suite 223 St. Paul, Minnesota 55101-2190	Grant Program: 2018 Hazardous Materials Emergency Preparedness Grant Agreement No.: A-HMEP-2018-MARSHACI-006
Grantee: City of Marshall 344 West Main Street Marshall, MN 56258-1313	Grant Agreement Term: Effective Date: 03/27/2019 Expiration Date: 09/30/2019
Grantee’s Authorized Representative: Marshall Division of Public Safety ATTN: Jim Marshall – Director of Public Safety 611 West Main Street Marshall, MN 56258 Phone: (507) 929-6300 E-mail: jim_marshall@ci.marshall.mn.us	Grant Agreement Amount: Original Agreement \$ 4,935.00 Matching Requirement \$ 1,233.75
State’s Authorized Representative: Matti Gurney Homeland Security and Emergency Management 445 Minnesota St., Suite 223 St. Paul, Minnesota 55101-2190 Phone: 651-201-7422 E-Mail: Matti.Gurney@state.mn.us	Federal Funding: CFDA 20.703 FAIN: HMHMP0569160100 State Funding: None Special Conditions: None

Under Minn. Stat. § 299A.01, Subd 2 (4) the State is empowered to enter into this grant agreement.

Term: Effective date is the date shown above or the date the State obtains all required signatures under Minn. Stat. § 16B.98, subd. 7, whichever is later. Once this grant agreement is fully executed, the Grantee may claim reimbursement for expenditures incurred pursuant to the Payment clause of this grant agreement. Reimbursements will only be made for those expenditures made according to the terms of this grant agreement. Expiration date is the date shown above or until all obligations have been satisfactorily fulfilled, whichever occurs first.

The Grantee, who is not a state employee will:

Perform and accomplish such purposes and activities as specified herein and in the Grantee’s approved 2018 Hazardous Materials Emergency Preparedness Application (“Application”) which is incorporated by reference into this grant agreement and on file with the State at Homeland Security and Emergency Management Division, 445 Minnesota Street, Suite 223, St. Paul, Minnesota 55101-2190. The Grantee shall also comply with all requirements referenced in the 2018 Hazardous Materials Emergency Preparedness Guidelines and Application which includes the Terms and Conditions and Grant Program Guidelines (<https://app.dps.mn.gov/egrants>), which are incorporated by reference into this grant agreement.

Budget Revisions: The breakdown of costs of the Grantee’s Budget is contained in Exhibit A, which is attached and incorporated into this grant agreement. As stated in the Grantee’s Application and Grant Program Guidelines, the Grantee will submit a written change request for any substitution of budget items or any deviation and in accordance with the Grant Program Guidelines. Requests must be approved prior to any expenditure by the Grantee.



Matching Requirements: (If applicable.) As stated in the Grantee’s Application, the Grantee certifies that the matching requirement will be met by the Grantee.

Payment: As stated in the Grantee’s Application and Grant Program Guidance, the State will promptly pay the Grantee after the Grantee presents an invoice for the services actually performed and the State's Authorized Representative accepts the invoiced services and in accordance with the Grant Program Guidelines. Payment will not be made if the Grantee has not satisfied reporting requirements.

Certification Regarding Lobbying: (If applicable.) Grantees receiving federal funds over \$100,000.00 must complete and return the Certification Regarding Lobbying form provided by the State to the Grantee.

1. ENCUMBRANCE VERIFICATION

Individual certifies that funds have been encumbered as required by Minn. Stat. §§ 16A.15 and 16C.05.

Signed: _____

Date: _____

3. STATE AGENCY

Signed: _____
(with delegated authority)

Title: _____

Date: _____

Grant Agreement No. A-HMEP-2018-MARSHACI-006 / PO#3000058957

2. GRANTEE

The Grantee certifies that the appropriate person(s) have executed the grant agreement on behalf of the Grantee as required by applicable articles, bylaws, resolutions, or ordinances.

Signed: _____

Print Name: _____

Title: _____

Date: _____

Signed: _____

Print Name: _____

Title: _____

Date: _____

Distribution: DPS/FAS
Grantee
State’s Authorized Representative

Budget Summary (Report)

Conference / Event: Cold Zone Conference		
Budget Category	Award	Match
(PLNG) Registration Fees		
Registration Fees	\$2,500.00	\$0.00
Total	\$2,500.00	\$0.00
(PLNG) Travel (Lodging & Per Diem)		
Lodging and Per Diem	\$2,435.00	\$0.00
Total	\$2,435.00	\$0.00
(PLNG) Personnel		
Wages	\$0.00	\$1,233.75
Total	\$0.00	\$1,233.75
Total	\$4,935.00	\$1,233.75

IMPORTANT SIGNATURE REQUIREMENTS

Authorization to execute grant agreements/amendments can be conferred by:

- 1) Statute, 2) Bylaws, or 3) Resolution

Resolution is not needed if the authorized officials below are signing the grant agreement. These officials may confer their grant signing authority to others by resolution, and they are the only acceptable signature on a resolution:

Statutory Cities	Mayor and City Clerk
County	Board Chair and Clerk of the Board
Non-Profit	Board Chair, or official authorized in bylaws

Legal authority for signing contracts for cities and counties is identified in statute. If not signed by the office/official(s) identified in statute, the authority may be delegated by resolution from the city council or county board. If a resolution delegates to more than one person and if the word “**and**” is used between the names, then **all named individuals must sign**. If a resolution uses the word “**or**” between the names, then **either individual may sign** the contract.

Statutory Cities: MS. 412.201 Execution of instruments

“Every contract, conveyance, license or other written instrument shall be executed on behalf of the city by the mayor and clerk, with the corporate seal affixed, and only pursuant to authority from the council.”

<https://www.revisor.leg.state.mn.us/statutes/?id=412.201>

Home Rule Charter Cities: MS. 410. Minneapolis, St. Paul and Duluth are the three Home Rule Charter Cities, sometimes referred to as “Cities of the First Class”. All three cities pass Resolutions that name an office/official(s) as authorized to sign a contract.

County Board: MS. 375.13 Chair

“The county board, at its first session in each year, shall elect from its members a chair and a vice-chair. The chair shall preside at its meetings and sign all documents requiring signature on its behalf. The chair’s signature, attested by the clerk of the county board, shall be binding as the signature of the board. In case of the absence or incapacity of the chair, the vice-chair shall perform the chair’s duties. If the chair or the vice-chair are absent from any meeting, all documents requiring the signature of the board shall be signed by a majority of it and attested by the clerk.”

<https://www.revisor.leg.state.mn.us/statutes/?id=375.13>



CITY OF MARSHALL AGENDA ITEM REPORT

Meeting Date:	Tuesday, April 23, 2019
Category:	CONSENT AGENDA
Type:	ACTION
Subject:	Consider an application for an On-Sale Intoxicating Liquor License for Marshall Convention and Visitors Bureau for May 17, 2019.
Background Information:	Attached is an application for a Temporary On-Sale Liquor License for Marshall Convention and Visitors Bureau for May 17, 2019 to use at the Red Baron Arena and Expo, Marshall, Minnesota.
Fiscal Impact:	\$30.00
Alternative/ Variations:	None
Recommendations:	the approval of a Temporary On-Sale Liquor License for Marshall Convention and Visitors Bureau for May 17, 2019 to use at the Red Baron Arena and Expo, Marshall, Minnesota.



Minnesota Department of Public Safety
 Alcohol and Gambling Enforcement Division
 445 Minnesota Street, Suite 222, St. Paul, MN 55101
 651-201-7500 Fax 651-297-5259 TTY 651-282-6555
**APPLICATION AND PERMIT FOR A 1 DAY
 TO 4 DAY TEMPORARY ON-SALE LIQUOR LICENSE**

Name of organization: Marshall Convention and Visitors Bureau
 Date organized: 4-18-19
 Tax exempt number: []

Address: 118 W College Drive
 City: Marshall
 State: Minnesota
 Zip Code: 56258

Name of person making application: Lauren Deutz
 Business phone: 507-537-1865
 Home phone: []

Date(s) of event: May 17, 2019
 Type of organization: Microdistillery Small Brewer
 Club Charitable Religious Other non-profit

Organization officer's name: Kelly Loft
 City: Marshall
 State: Minnesota
 Zip Code: 56258

Organization officer's name: []
 City: []
 State: Minnesota
 Zip Code: []

Organization officer's name: []
 City: []
 State: Minnesota
 Zip Code: []

Organization officer's name: []
 City: []
 State: Minnesota
 Zip Code: []

Location where permit will be used. If an outdoor area, describe.
 Red Baron Arena and Expo

If the applicant will contract for intoxicating liquor service give the name and address of the liquor license providing the service.

If the applicant will carry liquor liability insurance please provide the carrier's name and amount of coverage.
 Southwest Insurance Company
 2,000,000

APPROVAL

APPLICATION MUST BE APPROVED BY CITY OR COUNTY BEFORE SUBMITTING TO ALCOHOL AND GAMBLING ENFORCEMENT

Marshall
 City or County approving the license

\$30.00
 Fee Amount

Date Fee Paid

[Signature]
 Signature City Clerk or County Official

CLERKS NOTICE: Submit this form to Alcohol and Gambling Enforcement Division 30 days prior to event.

Date Approved

Permit Date

City or County E-mail Address

City or County Phone Number

Approved Director Alcohol and Gambling Enforcement

**ONE SUBMISSION PER EMAIL, APPLICATION ONLY.
 PLEASE PROVIDE A VALID E-MAIL ADDRESS FOR THE CITY/COUNTY AS ALL TEMPORARY PERMIT APPROVALS WILL BE SENT
 BACK VIA EMAIL. E-MAIL THE APPLICATION SIGNED BY CITY/COUNTY TO AGE.TEMPORARYAPPLICATION@STATE.MN.US**



CITY OF MARSHALL AGENDA ITEM REPORT

Meeting Date:	Tuesday, April 23, 2019
Category:	CONSENT AGENDA
Type:	ACTION
Subject:	Consider approval of the bills/project payments
Background Information:	Staff encourages the City Council Members to contact staff in advance of the meeting regarding these items if there are questions. Construction contract questions are encouraged to be directed to Director of Public Works Glenn Olson at 537-6773 or Finance Director Karla Drown at 537-6764
Fiscal Impact:	
Alternative/ Variations:	
Recommendations:	That the following bills and project payments be authorized for payment

PACKET: 06803 EFT Payments

VENDOR SET: 01

VENDOR SEQUENCE

VENDOR	ITEM NO#	DESCRIPTION	BANK	EFT DATE/#	STAT	DUE DT DISC DT	GROSS BALANCE	PAYMENT DISCOUNT	OUTSTANDING

01-0658	AP DESIGN								
I 70407		LEC BASEMENT BANNER	AP		E	5/04/2019	130.00 130.00	130.00CR	
I 70408		MAGNET LASER CUT	AP		E	5/04/2019	50.00 50.00	50.00CR	
			EFT				180.00 180.00	180.00CR 0.00	0.00

01-0934	D & G EXCAVATING INC								
I 81725		RIVER GATES	AP		E	5/08/2019	311.25 311.25	311.25CR	
			EFT				311.25 311.25	311.25CR 0.00	0.00

01-5731	DOLL DISTRIBUTING								
C 644000	.		AP		E	4/02/2019	123.45CR 123.45CR	123.45	
C 647343	.		AP		E	4/04/2019	65.08CR 65.08CR	65.08	
I 627745-1	.		AP		E	4/08/2019	0.05 0.05	0.05CR	
I 644001	.		AP		E	4/02/2019	4,379.05 4,379.05	4,379.05CR	
I 646227	.		AP		E	4/04/2019	646.80 646.80	646.80CR	
I 647642	.		AP		E	4/04/2019	2,195.50 2,195.50	2,195.50CR	
			EFT				7,032.87 7,032.87	7,032.87CR 0.00	0.00

PACKET: 06803 EFT Payments

VENDOR SET: 01

VENDOR SEQUENCE

VENDOR	ITEM NO#	DESCRIPTION	BANK	EFT DATE/#	STAT	DUE DT DISC DT	GROSS BALANCE	PAYMENT DISCOUNT	OUTSTANDING

01-6183	LEE, JERRED								
I	201904093382	2019 SAFETY SHOES-J LEE	AP		E	3/31/2019	159.95 159.95	159.95CR	
				EFT			159.95 159.95	159.95CR 0.00	0.00

01-1633	MARSHALL MUNICIPAL UTILITIE								
I	201904083378	02/25-03/26/19	AP		E	5/08/2019	82,157.15 82,157.15	82,157.15CR	
I	9764	04/19 WW BILLING	AP		E	5/04/2019	7,052.08 7,052.08	7,052.08CR	
I	9765	04/19 SWM UTILITY	AP		E	5/04/2019	2,794.83 2,794.83	2,794.83CR	
				EFT			92,004.06 92,004.06	92,004.06CR 0.00	0.00

01-1635	MARSHALL NORTHWEST PIPE FIT								
I	430991	PUMP	AP		E	5/03/2019	253.75 253.75	253.75CR	
I	431003	DRINKING FOUNTAIN	AP		E	5/04/2019	66.44 66.44	66.44CR	
				EFT			320.19 320.19	320.19CR 0.00	0.00

01-5891	ONE OFFICE SOLUTION								
C	C1868329-0	RETURN	AP		E	4/03/2019	33.99CR 33.99CR	33.99	
C	C1884328-0	SUPPLIES	AP		E	3/28/2019	10.77CR 10.77CR	10.77	
I	1884857-0	SUPPLIES	AP		E	3/29/2019	36.99 36.99	36.99CR	
I	1885836-0	SUPPLIES	AP		E	4/03/2019	126.49 126.49	126.49CR	

PACKET: 06803 EFT Payments

VENDOR SET: 01

VENDOR SEQUENCE

VENDOR	ITEM NO#	DESCRIPTION	BANK	EFT DATE/#	STAT	DUE DT DISC DT	GROSS BALANCE	PAYMENT DISCOUNT	OUTSTANDING

01-5891	ONE OFFICE SOLUTION	(CONT)							
I 1886211-0		SUPPLIES	AP		E	4/04/2019	99.98 99.98	99.98CR	
I 1887131-0		STAPLES	AP		E	4/05/2019	7.49 7.49	7.49CR	
I 1887133-0		GLUE STICKS	AP		E	4/05/2019	7.95 7.95	7.95CR	
I 1887134-0		MARKERS	AP		E	4/08/2019	5.45 5.45	5.45CR	
			EFT				239.59 239.59	239.59CR 0.00	0.00

01-2026	PEPSI COLA BOTTLING OF PIPE								
I 0002190556	.		AP		E	5/05/2019	23.70 23.70	23.70CR	
			EFT				23.70 23.70	23.70CR 0.00	0.00

01-0513	VANMOER, ROBERT								
I 201904083375	03/26/19	COLL SYS CONF-BROO	AP		E	4/28/2019	157.00 157.00	157.00CR	
			EFT				157.00 157.00	157.00CR 0.00	0.00

01-2538	VIKING COCA COLA BOTTLING C								
I 2310976	.		AP		E	5/03/2019	235.69 235.69	235.69CR	
			EFT				235.69 235.69	235.69CR 0.00	0.00

PACKET: 06803 EFT Payments

VENDOR SET: 01

VENDOR SEQUENCE

VENDOR	ITEM NO#	DESCRIPTION	BANK	EFT DATE/#	STAT	DUE DT DISC DT	GROSS BALANCE	PAYMENT DISCOUNT	OUTSTANDING

01-5727	WELSH, TRAVIS								
I	201904083377	03/26/19 COLL SYS CONF-BROO AP			E	4/03/2019	157.00 157.00	157.00CR	
			EFT				157.00 157.00	157.00CR 0.00	0.00

01-2632	ZIEGLER INC								
I	PC040326892	BACKHOE	AP		E	5/04/2019	22.40 22.40	22.40CR	
I	SW050316411	CONTROL PANEL FOR GENERATOR AP			E	5/02/2019	3,832.16 3,832.16	3,832.16CR	
			EFT				3,854.56 3,854.56	3,854.56CR 0.00	0.00

PACKET: 06803 EFT Payments

VENDOR SET: 01

=====
R E P O R T T O T A L S
=====

F U N D D I S T R I B U T I O N

FUND NO#	FUND NAME	AMOUNT
101	GENERAL FUND	47,932.84CR
207	PARKWAY ADDITION III & IV	16.62CR
230	TAX INCREMENT FINANCING	39.20CR
258	ASC ARENA	10,981.72CR
260	MARSHALL INDUSTRIAL FOUN	238.46CR
270	MERIT	707.36CR
495	PUBLIC IMPROVE REVOLVING	218.23CR
602	WASTEWATER OPERATING	30,664.56CR
609	LIQUOR	8,970.62CR
630	SURFACE WATER MGT UTILITY	4,906.25CR
** TOTALS **		104,675.86CR

---- TYPE OF CHECK TOTALS ----

	NUMBER	GROSS BALANCE	PAYMENT DISCOUNT	OUTSTANDING
HAND CHECKS		0.00	0.00	0.00
		0.00	0.00	
DRAFTS		0.00	0.00	0.00
		0.00	0.00	
REG-CHECKS		0.00	0.00	0.00
		0.00	0.00	
EFT		104,675.86	104,675.86CR	0.00
		104,675.86	0.00	
NON-CHECKS		0.00	0.00	0.00
		0.00	0.00	
ALL CHECKS		104,675.86	104,675.86CR	0.00
		104,675.86	0.00	

TOTAL CHECKS TO PRINT: 0

=====
ERRORS: 0 WARNINGS: 0
=====

VENDOR	NAME / I.D.	DESC	CHECK TYPE	CHECK DATE	DISCOUNT	AMOUNT	CHECK NO#	CHECK AMOUNT
4549	A & B BUSINESS, INC I-IN606211	04/06-05/05/19 CT2910-01	R	4/11/2019		58.50CR	112678	58.50
5813	ACE HOME & HARDWARE							
	I-89264	SUPPLIES	R	4/11/2019		13.18CR	112679	
	I-89519	VUCUUM FILTERS	R	4/11/2019		31.98CR	112679	
	I-89545	REPAIRS 2006 FORD	R	4/11/2019		9.57CR	112679	
	I-89550	CORD	R	4/11/2019		8.99CR	112679	
	I-89561	SUPPLIES	R	4/11/2019		14.00CR	112679	77.72
6128	ACTION CO LLC							
	I-100	03/19 SNOW HAULING	R	4/11/2019		4,646.25CR	112680	
	I-135	03/19 SNOW REMOVAL	R	4/11/2019		300.00CR	112680	4,946.25
5447	ARTISAN BEER COMPANY							
	I-3336108	.	R	4/11/2019		380.50CR	112681	
	I-3336109	.	R	4/11/2019		759.45CR	112681	1,139.95
0689	BEND RITE FABRICATION INC							
	I-41585	HOSE HOLDERS	R	4/11/2019		13.80CR	112682	
	I-41589	HOSE HOLDERS	R	4/11/2019		6.68CR	112682	20.48
0699	BEVERAGE WHOLESALERS							
	I-053612	.	R	4/11/2019		6,689.42CR	112683	6,689.42
5726	BOLLIG, MARK							
	I-201904083365	03826/19 COLL SYS CONF-BROOKLY	R	4/11/2019		157.00CR	112684	157.00
0018	BORDER STATES ELECTRIC SUPPLY							
	I-917435811	MATERIALS	R	4/11/2019		88.05CR	112685	
	I-917445311	MATERIALS	R	4/11/2019		49.31CR	112685	137.36
4457	BREAKTHRU BEVERAGE							
	C-2080226463	.	R	4/11/2019		43.00	112686	
	C-2080227322	.	R	4/11/2019		7.05	112686	
	C-2080230317	.	R	4/11/2019		40.00	112686	
	I-1080951157	.	R	4/11/2019		796.57CR	112686	
	I-1080951158	.	R	4/11/2019		448.00CR	112686	1,154.52
1	BREMER BANK							
	I-201904093379	SUBPOENA	R	4/11/2019		5.00CR	112687	5.00

VENDOR	NAME / I.D.	DESC	CHECK TYPE	CHECK DATE	DISCOUNT	AMOUNT	CHECK NO#	CHECK AMOUNT
6217	C & B OPERATIONS, LLC I-201904093380	PTO SHAFT	R	4/11/2019		600.00CR	112688	600.00
5352	CAMDEN INSURANCE AGENCY I-17321	2019 RENEWAL	R	4/11/2019		100.00CR	112689	100.00
0815	CATTOOR OIL COMPANY INC I-160767	GENERATOR FUEL	R	4/11/2019		1,300.50CR	112690	1,300.50
0818	CAUWELS, ROGER I-201904083366	03/24/19 COLL SYS CONF-BROOKLN	R	4/11/2019		138.00CR	112691	138.00
6294	CREDIT BUREAU OF ALEXANDRIA I-201904093381	PRE-EMPLOYMENT CREDIT CHECK	R	4/11/2019		87.00CR	112692	87.00
0919	CRYSTEEL I-LP189821	#10,#12 SANDER TRUCKS	R	4/11/2019		190.00CR	112693	190.00
1006	DOMINOS PIZZA I-201904083367	CONTRACTOR MTGS	R	4/11/2019		53.60CR	112694	53.60
1158	GALLS INC I-012338245	UNIFORMS-K SANDGREN	R	4/11/2019		169.98CR	112695	169.98
1201	GRAINGER INC C-9116277634 I-9126411520-1 I-9127219021-1 I-9127672773-1 I-9132598864	RETURN SOLENOID VALVE MANHOLE COVER HOOKS FILTERS SMALL TOOLS T KNOB	R R R R R	4/11/2019 4/11/2019 4/11/2019 4/11/2019 4/11/2019		233.81 204.09CR 100.80CR 107.63CR 2.43CR	112696 112696 112696 112696 112696	181.14
1243	HARDWARE HANK I-62341	BATHROOM SUPPLIES	R	4/11/2019		28.96CR	112697	28.96
4520	HARRISON TRUCK CENTERS I-X205030618:01 I-X205030741:01	#6 TRUCK BRAKE CHAMBER #10 SANDER	R R	4/11/2019 4/11/2019		68.52CR 68.52CR	112698 112698	137.04
1256	HAWKINS INC I-4471782	FERRIC CHLORIDE	R	4/11/2019		5,508.15CR	112699	5,508.15
1267	HEIMAN INC. I-34435	SVC FIRE EXTINGUISHERS	R	4/11/2019		148.00CR	112700	148.00

VENDOR	NAME / I.D.	DESC	CHECK TYPE	CHECK DATE	DISCOUNT	AMOUNT	CHECK NO#	CHECK AMOUNT
1271	HENLE PRINTING COMPANY							
	I-158924	ENVELOPES	R	4/11/2019		388.60CR	112701	
	I-159223	COMPLAINT FORMS	R	4/11/2019		58.73CR	112701	447.33
0435	HUBER, DORIS							
	I-201904083368	03/29/19 MAAP MTG-WILLMAR	R	4/11/2019		81.20CR	112702	81.20
1393	JH LARSON ELECTRICAL COMPANY							
	I-S101969980.001	A/D BULBS	R	4/11/2019		54.60CR	112703	
	I-S101970120.001	SHOP/HANGAR BULBS	R	4/11/2019		61.41CR	112703	116.01
1399	JOHNSON BROTHERS LIQUOR COMPANY							
	I-1258519	.	R	4/11/2019		5,705.79CR	112704	
	I-1258520	.	R	4/11/2019		3,931.70CR	112704	
	I-1258521	.	R	4/11/2019		112.25CR	112704	9,749.74
3564	KESTELOOT ENTERPRISES, INC							
	I-IN36047	KUBOTA BLOWER	R	4/11/2019		121.39CR	112705	121.39
4140	KRUSE FORD-LINCOLN-MERCURY, INC							
	I-122530	BATTERY	R	4/11/2019		129.95CR	112706	129.95
3653	LANGUAGE LINE SERVICES							
	I-4540179	03/19 SVC	R	4/11/2019		40.32CR	112707	40.32
1483	LEAGUE OF MINNESOTA CITIES INS TRUST							
	I-00076406	CLM# 00074606	R	4/11/2019		43.73CR	112708	
	I-13918	CLM# 00071192	R	4/11/2019		831.23CR	112708	874.96
1508	LOCKWOOD MOTORS INC.							
	I-44828	CHEV 1 TON	R	4/11/2019		130.60CR	112709	
	I-CW05662803	CAR WASHES	R	4/11/2019		39.68CR	112709	170.28
1531	LYON COUNTY AUDITOR-TREASURER							
	I-109	01/19-03/19 IT SVC	R	4/11/2019		2,500.00CR	112710	2,500.00
1555	LYON LINCOLN ELECTRIC COOPERATIVE INC							
	I-201904083369	02/27-03/30/19	R	4/11/2019		42.64CR	112711	42.64
6292	MADDEN, GALANTER, HANSEN, LLP							
	I-201904083370	03/19 SVC	R	4/11/2019		944.00CR	112712	944.00

VENDOR	NAME / I.D.	DESC	CHECK TYPE	CHECK DATE	DISCOUNT	AMOUNT	CHECK NO#	CHECK AMOUNT
1616	MARSHALL CONVENTION & VISITORS BUREAU							
	I-201904113389	01/19 LODGING TAX	R	4/11/2019		10,294.58CR	112713	
	I-201904113390	02/19 LADGING TAX	R	4/11/2019		11,274.05CR	112713	21,568.63
1623	MARSHALL INDEPENDENT, INC							
	I-051480	BLOCK 11 AD	R	4/11/2019		197.10CR	112714	197.10
1649	MARSHALL TRUCK SALVAGE INC.							
	I-62475	CABLE TIES	R	4/11/2019		28.00CR	112715	28.00
4980	MENARDS INC							
	I-37242	WIRE MOLD	R	4/11/2019		38.97CR	112716	
	I-37341	SUPPLIES	R	4/11/2019		6.59CR	112716	
	I-37357	SUPPLIES	R	4/11/2019		33.53CR	112716	79.09
6230	MILLNER HERITAGE VINEYARD & WINERY							
	I-1-4-3-19-1	.	R	4/11/2019		87.00CR	112717	87.00
1844	MN WEST COMMUNITY & TECH COLLEGE							
	I-201904083371	BPOILER CLASS, T CHAMPAGNE	R	4/11/2019		229.00CR	112718	
	I-201904083372	BOILER CLASS, L DEPESTEL	R	4/11/2019		229.00CR	112718	458.00
1864	MONTES ELECTRIC INC							
	I-17956	WATER HEATER-SHOP	R	4/11/2019		119.39CR	112719	
	I-17971	WASH BAY DOOR	R	4/11/2019		289.59CR	112719	408.98
1945	NORMS GTC							
	I-7480-93218	FILTER	R	4/11/2019		22.56CR	112720	22.56
1986	NORTH CENTRAL INTERNATIONAL, INC							
	C-CM353230	OSHKOSH PLOW	R	4/11/2019		30.94	112721	
	I-353284	OSHKOSH PLOW	R	4/11/2019		66.00CR	112721	
	I-353317	OSHKOSH BLOWER FILTER	R	4/11/2019		18.54CR	112721	
	I-353328	OSHKOSH PLOW	R	4/11/2019		91.76CR	112721	
	I-353369	SWEEPER	R	4/11/2019		21.72CR	112721	167.08
4166	OLSEN, JAKE							
	I-201904083373	03/15/19 FIRE SCHOOL, DULUTH	R	4/11/2019		704.14CR	112722	704.14
4060	PAGE, BRIAN							
	I-201904083374	03/26/19 COLL SYS CONF-BROOKLY	R	4/11/2019		157.00CR	112723	157.00

VENDOR	NAME / I.D.	DESC	CHECK TYPE	CHECK DATE	DISCOUNT	AMOUNT	CHECK NO#	CHECK AMOUNT
2036	PHILLIPS WINE AND SPIRITS INC							
	I-2532022	.	R	4/11/2019		9,729.19CR	112724	
	I-2532023	.	R	4/11/2019		2,499.31CR	112724	12,228.50
3557	POMP'S TIRE SERVICE, INC.							
	I-680042214	MOTORGRADER TIRES	R	4/11/2019		128.00CR	112725	128.00
1533	PRAIRIE PRIDE COOPERATIVE							
	I-120897	BULK FUEL	R	4/11/2019		1,880.00CR	112726	1,880.00
6166	PULVER MOTOR SVC, LLC							
	I-152401	TOW	R	4/11/2019		75.00CR	112727	
	I-152402	TOW	R	4/11/2019		75.00CR	112727	
	I-152403	TOW	R	4/11/2019		75.00CR	112727	
	I-152404	TOW	R	4/11/2019		75.00CR	112727	
	I-152405	TOW & STORAGE	R	4/11/2019		75.00CR	112727	
	I-152406	TOW	R	4/11/2019		75.00CR	112727	
	I-152407	TOW	R	4/11/2019		75.00CR	112727	
	I-152408	TOW	R	4/11/2019		75.00CR	112727	
	I-152409	TOW	R	4/11/2019		75.00CR	112727	
	I-154136	ICR# 19-1673	R	4/11/2019		495.00CR	112727	
	I-155075	ICR# 19-2612	R	4/11/2019		75.00CR	112727	1,245.00
2096	QUARNSTROM & DOERING, PA							
	I-M007-055,S71665	02/19 ACTION MANUFACTURING	R	4/11/2019		400.55CR	112728	400.55
6365	RJM DISTRIBUTING, INC							
	I-IND018392	.	R	4/11/2019		344.70CR	112729	344.70
2201	RUNNINGS SUPPLY INC							
	I-4614798	FLAG HOOKS	R	4/11/2019		9.54CR	112730	9.54
4855	SOUTHERN GLAZER'S OF MN							
	I-1804159	.	R	4/11/2019		2,466.45CR	112731	
	I-1804160	.	R	4/11/2019		411.60CR	112731	
	I-5040995	.	R	4/11/2019		8,575.40CR	112731	
	I-5040997	.	R	4/11/2019		1,422.50CR	112731	
	I-5040998	.	R	4/11/2019		267.60CR	112731	13,143.55
6324	HOOK, MATT							
	I-1635	03/26/19 SVC	R	4/11/2019		50.00CR	112732	50.00

VENDOR	NAME / I.D.	DESC	CHECK TYPE	CHECK DATE	DISCOUNT	AMOUNT	CHECK NO#	CHECK AMOUNT
2395	SWEDE'S SERVICE CENTER I-26111	SKIDLOADER	R	4/11/2019		50.16CR	112733	50.16
6137	TEIGS LAWN CARE & LANDSCAPING, LLC							
	I-201904103385	03/19 600 W MAIN ST	R	4/11/2019		50.00CR	112734	
	I-201904103386	03/19 407 W MAIN ST	R	4/11/2019		25.00CR	112734	
	I-201904103387	03/19 106 C ST	R	4/11/2019		25.00CR	112734	
	I-201904103388	03/19 WALK BRIDGES	R	4/11/2019		180.00CR	112734	280.00
2428	TITAN MACHINERY							
	C-12141671GP	PD 2X	R	4/11/2019		532.95	112735	
	I-10057743CL	321 REPAIRS	R	4/11/2019		213.40CR	112735	
	I-12184915GP	3 YR WAARANTY 321 LOADER	R	4/11/2019		1,127.00CR	112735	
	I-12192424GP	321F SNOW BUCKET	R	4/11/2019		432.06CR	112735	
	I-12208389GP	AUGER POWER UNIT	R	4/11/2019		4,797.00CR	112735	6,036.51
2477	UNIQUE PAVING MATERIALS CORPORATION							
	I-43084	POT HOLE PATCH	R	4/11/2019		1,810.43CR	112736	1,810.43
4118	WALMART BUSINESS							
	I-201904083376	SALES TAX	R	4/11/2019		0.47CR	112737	0.47
2591	WESTERN PRINT GROUP							
	I-00223	TICKET ENVELOPES	R	4/11/2019		397.61CR	112738	397.61
0522	WINTER, RICHARD							
	I-201904103383	RPZ TESTING	R	4/11/2019		370.00CR	112739	370.00
5237	YOUNGSMA, LUCAS							
	I-201904103384	AMAZON REIMBURSEMENT	R	4/11/2019		138.03CR	112740	138.03

* * T O T A L S * *	NO#	DISCOUNTS	CHECK AMT	TOTAL APPLIED
REGULAR CHECKS:	63	0.00	100,637.02	100,637.02
HANDWRITTEN CHECKS:	0	0.00	0.00	0.00
PRE-WRITE CHECKS:	0	0.00	0.00	0.00
DRAFTS:	0	0.00	0.00	0.00
VOID CHECKS:	0	0.00	0.00	0.00
NON CHECKS:	0	0.00	0.00	0.00
CORRECTIONS:	0	0.00	0.00	0.00
REGISTER TOTALS:	63	0.00	100,637.02	100,637.02

TOTAL ERRORS: 0 TOTAL WARNINGS: 0

VENDOR	NAME / I.D.	DESC	CHECK TYPE	CHECK DATE	DISCOUNT	AMOUNT	CHECK NO#	CHECK AMOUNT
--------	-------------	------	---------------	---------------	----------	--------	--------------	-----------------

** POSTING PERIOD RECAP **

FUND	PERIOD	AMOUNT
101	4/2019	47,173.70CR
208	4/2019	197.10CR
258	4/2019	1,758.50CR
260	4/2019	400.55CR
602	4/2019	6,248.07CR
609	4/2019	44,837.38CR
630	4/2019	21.72CR
=====		
ALL		100,637.02CR

VENDOR	I.D.	NAME	ITEM TYPE	ITEM DATE	DISCOUNT	AMOUNT	ITEM NO#	ITEM AMOUNT
4805		FURTHER						
	I-5FH201904173404	EMPLOYER CONTRIB FAM HSA 5000	D	4/19/2019		4,167.00	000838	
	I-5FV201904173404	EMPLOYER CONT FAM VEBA 5000	D	4/19/2019		750.00	000838	
	I-5SH201904173404	EMPLOYER CONTRIB SNGL HSA 5000	D	4/19/2019		1,812.50	000838	
	I-5SV201904173404	EMPLOYER CONT SINGL VEBA 5000	D	4/19/2019		729.19	000838	
	I-HEC201904173404	EMPLOYEE HSA CONTRIBUTION	D	4/19/2019		8,985.03	000838	16,443.72
1358		INTERNAL REVENUE SERVICE						
	I-T1 201904173404	FEDERAL W/H	D	4/19/2019		21,580.04	000839	
	I-T3 201904173404	SOCIAL SECURITY W/H	D	4/19/2019		24,180.54	000839	
	I-T4 201904173404	MEDICARE W/H	D	4/19/2019		7,246.42	000839	53,007.00
3669		MINNESOTA STATE RETIREMENT SYST						
	I-27A201904173404	HEALTH CARE SAVINGS PLAN	D	4/19/2019		941.91	000840	
	I-27B201904173404	HEALTH CARE SAVINGS PLAN	D	4/19/2019		170.00	000840	
	I-27L201904173404	HEALTH CARE SAVINGS PLAN	D	4/19/2019		1,200.00	000840	
	I-27N201904173404	HEALTH CARE SAVINGS PLAN	D	4/19/2019		2,418.71	000840	
	I-27S201904173404	HEALTH CARE SAVINGS PLAN	D	4/19/2019		100.00	000840	
	I-36 201904173404	MNDP - DEFERRED COMP	D	4/19/2019		1,160.00	000840	
	I-36R201904173404	MNDP - ROTH	D	4/19/2019		340.00	000840	6,330.62
1818		MN REVENUE						
	I-T2 201904173404	STATE W/H	D	4/19/2019		10,864.84	000841	10,864.84
2512		NATIONWIDE RETIREMENT						
	I-33 201904173404	USCM	D	4/19/2019		1,025.00	000842	1,025.00
2513		NATIONWIDE RETIREMENT-FIRE						
	I-34 201904173404	USCM FIRE DEPT	D	4/19/2019		843.98	000843	843.98
2028		PERA OF MINNESOTA REG						
	I-11 201904173404	PERA COUNCIL	D	4/19/2019		340.90	000844	
	I-12 201904173404	PERA POLICE AND FIRE	D	4/19/2019		16,493.64	000844	
	I-13 201904173404	PERA COORDINATED	D	4/19/2019		29,465.36	000844	46,299.90
3443		VALIC DEFERRED COMP						
	I-35 201904173404	VALIC DEFERRED COMP	D	4/19/2019		997.00	000845	
	I-35F201904173404	VALIC - FIRE DEPARTMENT	D	4/19/2019		114.07	000845	
	I-35R201904173404	VALIC ROTH	D	4/19/2019		1,250.00	000845	2,361.07
6085		VOYA - INVESTORS CHOICE						
	I-37D201904173404	VOYA DEFERRED	D	4/19/2019		350.00	000846	
	I-37R201904173404	VOYA ROTH PLAN	D	4/19/2019		850.00	000846	1,200.00

PACKET: 06813 04/19/2019 Payroll Entrie

VENDOR SET: 01 City of Marshall

*** DRAFT/OTHER LISTING ***

BANK: AP REG AP

VENDOR	I.D.	NAME	ITEM TYPE	ITEM DATE	DISCOUNT	AMOUNT	ITEM NO#	ITEM AMOUNT
--------	------	------	--------------	--------------	----------	--------	-------------	----------------

* * B A N K T O T A L S * *	NO#	DISCOUNTS	CHECK AMT	TOTAL APPLIED
REGULAR CHECKS:	0	0.00	0.00	0.00
HANDWRITTEN CHECKS:	0	0.00	0.00	0.00
PRE-WRITE CHECKS:	0	0.00	0.00	0.00
DRAFTS:	9	0.00	138,376.13	138,376.13
VOID CHECKS:	0	0.00	0.00	0.00
NON CHECKS:	0	0.00	0.00	0.00
CORRECTIONS:	0	0.00	0.00	0.00
BANK TOTALS:	9	0.00	138,376.13	138,376.13

PACKET: 06813 04/19/2019 Payroll Entry
VENDOR SET: 01 City of Marshall
BANK: ALL

*** DRAFT/OTHER LISTING ***

** REGISTER GRAND TOTALS *

* * T O T A L S * *	NO#	DISCOUNTS	CHECK AMT	TOTAL APPLIED
REGULAR CHECKS:	0	0.00	0.00	0.00
HANDWRITTEN CHECKS:	0	0.00	0.00	0.00
PRE-WRITE CHECKS:	0	0.00	0.00	0.00
DRAFTS:	9	0.00	138,376.13	138,376.13
VOID CHECKS:	0	0.00	0.00	0.00
NON CHECKS:	0	0.00	0.00	0.00
CORRECTIONS:	0	0.00	0.00	0.00
REGISTER TOTALS:	9	0.00	138,376.13	138,376.13

** POSTING PERIOD RECAP **

FUND	PERIOD	AMOUNT
101	4/2019	102,402.60CR
211	4/2019	9,849.09CR
258	4/2019	2,762.72CR
270	4/2019	1,009.16CR
602	4/2019	16,883.54CR
609	4/2019	5,469.02CR
ALL		138,376.13CR

TOTAL ERRORS: 0

TOTAL WARNINGS: 0

PACKET: 06819 EFT Payments

VENDOR SET: 01

VENDOR SEQUENCE

VENDOR	ITEM NO#	DESCRIPTION	BANK	EFT DATE/#	STAT	DUE DT DISC DT	GROSS BALANCE	PAYMENT DISCOUNT	OUTSTANDING

01-0688	BELLBOY CORPORATION								
I	0069105700	.	AP		E	5/12/2019	1,365.00 1,365.00	1,365.00CR	
I	0069169700	.	AP		E	5/12/2019	1,185.00 1,185.00	1,185.00CR	
I	0099274900	.	AP		E	5/03/2019	74.12 74.12	74.12CR	
I	0099292100	.	AP		E	5/12/2019	471.82 471.82	471.82CR	
I	0099312300	.	AP		E	5/12/2019	77.96 77.96	77.96CR	
				EFT			3,173.90 3,173.90	3,173.90CR 0.00	0.00

01-0384	COUDRON, DEAN								
I	4605797	WATER BOOTS	AP		E	5/01/2019	189.95 189.95	189.95CR	
				EFT			189.95 189.95	189.95CR 0.00	0.00

01-0934	D & G EXCAVATING INC								
I	81750	REPAIR PIPE	AP		E	5/09/2019	2,305.55 2,305.55	2,305.55CR	
				EFT			2,305.55 2,305.55	2,305.55CR 0.00	0.00

01-5731	DOLL DISTRIBUTING								
C	629423	.	AP		E	3/12/2019	44.53CR 44.53CR	44.53	
C	647398	.	AP		E	4/05/2019	161.15CR 161.15CR	161.15	
C	649133	.	AP		E	4/09/2019	14.91CR 14.91CR	14.91	

PACKET: 06819 EFT Payments

VENDOR SET: 01

VENDOR SEQUENCE

VENDOR	ITEM NO#	DESCRIPTION	BANK	EFT DATE/#	STAT	DUE DT DISC DT	GROSS BALANCE	PAYMENT DISCOUNT	OUTSTANDING

01-5731	DOLL	DISTRIBUTING				(CONT)			
C	652368	.	AP		E	4/12/2019	153.60CR 153.60CR	153.60	
I	054895	.	AP		E	4/16/2019	15,624.23 15,624.23	15,624.23CR	
I	647399	.	AP		E	4/05/2019	276.00 276.00	276.00CR	
I	649132	.	AP		E	4/09/2019	7,606.35 7,606.35	7,606.35CR	
I	652367	.	AP		E	4/12/2019	4,606.70 4,606.70	4,606.70CR	
I	654122	.	AP		E	4/16/2019	8,235.90 8,235.90	8,235.90CR	
				EFT			35,974.99 35,974.99	35,974.99CR 0.00	0.00

01-1090	FASTENAL	COMPANY							
I	96364	MATERIALS	AP		E	4/24/2019	45.67 45.67	45.67CR	
I	96532	.SUPPLIES	AP		E	5/09/2019	107.15 107.15	107.15CR	
I	96553	BOLTS	AP		E	5/05/2019	3.41 3.41	3.41CR	
I	96589	HELI COILS	AP		E	5/05/2019	7.84 7.84	7.84CR	
				EFT			164.07 164.07	164.07CR 0.00	0.00

01-1480	LAW ENFORCEMENT	LABOR SERVI							
I	80 201904173404	LELS UNION DUES	AP		E	4/19/2019	918.00 918.00	918.00CR	
				EFT			918.00 918.00	918.00CR 0.00	0.00

PACKET: 06819 EFT Payments

VENDOR SET: 01

VENDOR SEQUENCE

VENDOR	ITEM NO#	DESCRIPTION	BANK	EFT DATE/#	STAT	DUE DT DISC DT	GROSS BALANCE	PAYMENT DISCOUNT	OUTSTANDING

01-1635	MARSHALL NORTHWEST PIPE FIT								
I	430864	GASKET	AP		E	5/03/2019	67.94 67.94	67.94CR	
				EFT			67.94 67.94	67.94CR 0.00	0.00

01-1986	NORTH CENTRAL INTERNATIONAL								
C	CM353230	OSHKOSH PLOW	AP		E	4/04/2019	30.94CR 30.94CR	30.94	
I	353284	OSHKOSH PLOW	AP		E	5/04/2019	66.00 66.00	66.00CR	
I	353317	OSHKOSH BLOWER FILTER	AP		E	5/04/2019	18.54 18.54	18.54CR	
I	353328	OSHKOSH PLOW	AP		E	5/04/2019	91.76 91.76	91.76CR	
I	353369	SWEEPER	AP		E	5/04/2019	21.72 21.72	21.72CR	
I	353481	LIGHT DOMES	AP		E	5/11/2019	46.73 46.73	46.73CR	
				EFT			213.81 213.81	213.81CR 0.00	0.00

01-5891	ONE OFFICE SOLUTION								
C	C1855707-0	RETURNS	AP		E	3/28/2019	28.04CR 28.04CR	28.04	
I	1844328-0	SUPPLIES	AP		E	3/28/2019	35.90 35.90	35.90CR	
I	1887086-0	LABELS	AP		E	4/08/2019	24.25 24.25	24.25CR	
I	1888939-0	DRY ERASERS	AP		E	4/16/2019	5.00 5.00	5.00CR	
				EFT			37.11 37.11	37.11CR 0.00	0.00

PACKET: 06819 EFT Payments

VENDOR SET: 01

VENDOR SEQUENCE

VENDOR	ITEM NO#	DESCRIPTION	BANK	EFT DATE/#	STAT	DUE DT DISC DT	GROSS BALANCE	PAYMENT DISCOUNT	OUTSTANDING

01-2026	PEPSI COLA BOTTLING OF PIPE								
I 002192879	.		AP		E	5/10/2019	11.85 11.85	11.85CR	
				EFT			11.85 11.85	11.85CR 0.00	0.00

01-6126	UNITED COMMUNITY ACTION PAR								
I 5627	PROGRAMMING		AP		E	3/28/2019	20.00 20.00	20.00CR	
				EFT			20.00 20.00	20.00CR 0.00	0.00

01-2538	VIKING COCA COLA BOTTLING C								
I 2322848	.		AP		E	5/10/2019	128.00 128.00	128.00CR	
				EFT			128.00 128.00	128.00CR 0.00	0.00

01-2632	ZIEGLER INC								
I PC040327401	CLAM BUCKET		AP		E	5/10/2019	20.94 20.94	20.94CR	
				EFT			20.94 20.94	20.94CR 0.00	0.00

PACKET: 06819 EFT Payments

VENDOR SET: 01

===== R E P O R T T O T A L S =====

F U N D D I S T R I B U T I O N

FUND NO#	FUND NAME	AMOUNT
101	GENERAL FUND	1,310.50CR
602	WASTEWATER OPERATING	2,573.04CR
609	LIQUOR	39,320.85CR
630	SURFACE WATER MGT UTILITY	21.72CR
** TOTALS **		43,226.11CR

----- TYPE OF CHECK TOTALS -----

	NUMBER	GROSS BALANCE	PAYMENT DISCOUNT	OUTSTANDING
HAND CHECKS		0.00 0.00	0.00 0.00	0.00
DRAFTS		0.00 0.00	0.00 0.00	0.00
REG-CHECKS		0.00 0.00	0.00 0.00	0.00
EFT		43,226.11 43,226.11	43,226.11CR 0.00	0.00
NON-CHECKS		0.00 0.00	0.00 0.00	0.00
ALL CHECKS		43,226.11 43,226.11	43,226.11CR 0.00	0.00

TOTAL CHECKS TO PRINT: 0

ERRORS: 0 WARNINGS: 0

CITY OF MARSHALL, MINNESOTA
 PRIOR AND CURRENT YEARS CONSTRUCTION CONTRACTS
 4/18/2019

PROJECT #:	Coding	DATE	CONTRACTOR:	ORIGINAL CONTRACT AMOUNT:	CHANGE ORDERS	CURRENT CONTRACT AMOUNT	2017 PRIOR PAYMENTS	2018 Prior Payments	2019 Prior Payments	PYMTS THIS MEETING:	RETAINAGE	BALANCE:	PERCENT COMPLETE
Z47	475-70276-5520		Justice Park Bathroom	Doom & Cuypers Construction	117,867.00	460.00	118,327.00	0.00	46,762.80	37,260.90	4,422.30	29,881.00	74.75%
Z67	462-60211-5570	10/3/2017	Commerce Industrial Park/Michigan Road Imp	Midwest Contracting	4,004,847.25	26,544.00	4,031,391.25	1,644,399.13	1,598,388.75		170,673.05	617,930.32	84.67%
Z67	475-60211-5570	6/12/2018	Michigan Road/Superior Road Reonstruction	D & G Excavating	1,022,427.60	2,050.00	1,024,477.60	-	959,481.14		50,499.01	14,497.45	98.58%
Z64	475-60211-5570	6/1/2018	Saratoga Street Recon (4th - Southview)	R & G Construction	2,846,784.60	42,077.45	2,888,862.05	-	2,721,729.47	21,800.66	144,396.32	935.60	99.97%
					<u>7,991,926.45</u>	<u>71,131.45</u>	<u>8,063,057.90</u>	<u>1,644,399.13</u>	<u>5,326,362.16</u>	<u>0.00</u>	<u>369,990.68</u>	<u>663,244.37</u>	

VENDOR	NAME / I.D.	DESC	CHECK TYPE	CHECK DATE	DISCOUNT	AMOUNT	CHECK NO#	CHECK AMOUNT
4549	A & B BUSINESS, INC							
	I-IN603780	CT6544-01, 04/01-04/30/19	R	4/19/2019		394.73CR	112786	
	I-IN606083	CT2911-01, 04/06-05/05/19	R	4/19/2019		350.40CR	112786	745.13
5968	ABRASIVES INC							
	I-087369	SAND BLASTING SAND	R	4/19/2019		632.80CR	112787	632.80
5813	ACE HOME & HARDWARE							
	I-89477	SUPPLIES	R	4/19/2019		1.13CR	112788	
	I-89478	SUPPLIES	R	4/19/2019		43.87CR	112788	
	I-89581	SPRING SNAPS	R	4/19/2019		31.10CR	112788	
	I-89730	WASH BRUSH HANDLE	R	4/19/2019		8.59CR	112788	
	I-89803	LIGHT BULBS	R	4/19/2019		5.99CR	112788	
	I-89998	SUPPLIES	R	4/19/2019		7.74CR	112788	
	I-90029	SUPPLIES	R	4/19/2019		3.86CR	112788	102.28
0819	AMERICAN GARAGE DOOR CO.							
	I-MN21455	GARAGE DOOR REPAIR	R	4/19/2019		90.00CR	112789	90.00
0595	AMERIPRIDE SERVICES, INC							
	I-2801015534	DUST MOP, TOWELS	R	4/19/2019		77.35CR	112790	
	I-280105522	.	R	4/19/2019		138.14CR	112790	215.49
5880	AMERITAS LIFE INSURANCE CORP							
	I-29 201904033351	VISION INSURANCE	R	4/19/2019		17.85CR	112791	
	I-29 201904173404	VISION INSURANCE	R	4/19/2019		307.31CR	112791	325.16
0630	ARCTIC GLACIER							
	I-1947910002	.	R	4/19/2019		205.61CR	112792	205.61
0629	ARNOLD MOTOR SUPPLY							
	I-02NV017183	OIL FILTER	R	4/19/2019		27.43CR	112793	27.43
5447	ARTISAN BEER COMPANY							
	I-3337631	.	R	4/19/2019		834.25CR	112794	834.25
0648	AUTOMATIC SYSTEMS CO.							
	I-33307S	WIN911 MODEM	R	4/19/2019		502.10CR	112795	502.10
5876	BANK BREWING CO							
	I-185783	.	R	4/19/2019		464.00CR	112796	464.00

VENDOR	NAME / I.D.	DESC	CHECK TYPE	CHECK DATE	DISCOUNT	AMOUNT	CHECK NO#	CHECK AMOUNT
0699	BEVERAGE WHOLESALERS							
	C-051260	.	R	4/19/2019		26.00	112797	
	I-053904	.	R	4/19/2019		11,462.00CR	112797	
	I-054542	.	R	4/19/2019		4,669.00CR	112797	16,105.00
0018	BORDER STATES ELECTRIC SUPPLY							
	I-917489486	MATERIALS	R	4/19/2019		22.78CR	112798	22.78
4457	BREAKTHRU BEVERAGE							
	I-1080955369	.	R	4/19/2019		292.00CR	112799	
	I-1080955370	.	R	4/19/2019		4,325.04CR	112799	
	I-1080955371	.	R	4/19/2019		245.86CR	112799	4,862.90
0774	BUREAU OF CRIMINAL APPREHENSION							
	I-00000536443	Q1 2019 CJDN ACCESS FEE	R	4/19/2019		630.00CR	112800	630.00
0815	CATTOOR OIL COMPANY INC							
	I-160901	BULK FUEL	R	4/19/2019		2,099.50CR	112801	
	I-5246	#6 DEF FLUID	R	4/19/2019		11.25CR	112801	2,110.75
5860	CENTRAL STATES GROUP							
	C-7018370-00	RETURN	R	4/19/2019		105.00	112802	
	I-7018358-00	CLAMPS	R	4/19/2019		70.11CR	112802	
	I-7018358-01	CLAMPS	R	4/19/2019		77.90CR	112802	
	I-7018358-02	.	R	4/19/2019		7.79CR	112802	50.80
0836	CHARTER COMMUNICATIONS							
	I-201904163392	04/01-04/30/19	R	4/19/2019		11.99CR	112803	11.99
0920	CULLIGAN WATER CONDITIONING OF MARSHALL							
	I-201904163393	WATER	R	4/19/2019		6.30CR	112804	6.30
3819	DACOTAH PAPER CO							
	I-47131	SUPPLIES	R	4/19/2019		46.68CR	112805	46.68
6248	ENGAN ASSOCIATES P.A.							
	I-2019-050	MUNICIPAL BLDG-PHASE II	R	4/19/2019		16,736.94CR	112806	16,736.94
4753	ENTERPRISE LEASING CO							
	I-20717852	04/04/19 G OLSON	R	4/19/2019		48.83CR	112807	48.83
6127	GRANDVIEW VALLEY WINERY, INC							
	I-13416	.	R	4/19/2019		396.00CR	112808	396.00

VENDOR	NAME / I.D.	DESC	CHECK TYPE	CHECK DATE	DISCOUNT	AMOUNT	CHECK NO#	CHECK AMOUNT
5725	HADLEY LION'S CLUB I-201904163394	HADLEY BB TOURNAMENT	R	4/19/2019		50.00CR	112809	50.00
1267	HEIMAN INC. I-0877940-IN	TURNOUT REPAIR	R	4/19/2019		291.00CR	112810	291.00
1280	HP INC I-60897932	COMPUTERS	R	4/19/2019		8,433.48CR	112811	8,433.48
1325	ICMA RETIREMENT TRUST #300877 I-31 201904173404	ICMA DEFERRED COMP	R	4/19/2019		300.00CR	112812	300.00
1399	JOHNSON BROTHERS LIQUOR COMPANY I-1253892 I-1263683 I-1263684	. . .	R R R	4/19/2019 4/19/2019 4/19/2019		497.13CR 6,189.27CR 4,066.25CR	112813 112813 112813	10,752.65
1417	KENNEDY & GRAVEN, CHARTERED I-147621 I-147699	GENERAL PUBLIC FINANCE MATTERS GENERAL MATTERS	R R	4/19/2019 4/19/2019		288.00CR 1,357.50CR	112814 112814	1,645.50
1481	LEAGUE OF MINNESOTA CITIES I-291789	2019 LMC CONF-A STORM	R	4/19/2019		180.00CR	112815	180.00
1508	LOCKWOOD MOTORS INC. I-44914 I-CW040819	GUARD KIT CAR WASHES	R R	4/19/2019 4/19/2019		116.00CR 70.00CR	112816 112816	186.00
1531	LYON COUNTY AUDITOR-TREASURER I-201904173400 I-201904173401	Q1 2019 LEC OM CHGS 03/30/19-04/29/19	R R	4/19/2019 4/19/2019		20,715.20CR 643.80CR	112817 112817	21,359.00
5577	LYON COUNTY HAZARDOUS WASTE FACILITY I-0434428	TV DISPOSAL	R	4/19/2019		20.00CR	112818	20.00
1545	LYON COUNTY HIGHWAY DEPARTMENT I-201904163395 I-201904173403 I-201904173405	MERIT TRACK UTILITY PRMT SUP/HOR UTILITY PERMIT 03/19 FUEL	R R R	4/19/2019 4/19/2019 4/19/2019		50.00CR 450.00CR 17,097.74CR	112819 112819 112819	17,597.74
VOID	VOID CHECK		V	4/19/2019			112820	**VOID**

VENDOR	NAME / I.D.	DESC	CHECK TYPE	CHECK DATE	DISCOUNT	AMOUNT	CHECK NO#	CHECK AMOUNT
1552	LYON COUNTY RECORDER I-201945-1	03/19 LAREDO	R	4/19/2019		61.75CR	112821	61.75
1575	MAILBOXES & PARCEL DEPOT I-79869	STORMWATER TEST	R	4/19/2019		17.52CR	112822	17.52
6381	MARSARS WATER RESCUE SYSTEMS, INC I-11980	RESCUE ROPES/EQUIPMENT	R	4/19/2019		1,520.87CR	112823	1,520.87
1623	MARSHALL INDEPENDENT, INC I-051481	03/19 DISPLAY	R	4/19/2019		232.00CR	112824	232.00
1649	MARSHALL TRUCK SALVAGE INC. I-62476	SKIDLOADER	R	4/19/2019		32.00CR	112825	32.00
4611	MARTIN TRUCKING I-830902475	03/19 SVC	R	4/19/2019		2,374.30CR	112826	2,374.30
4980	MENARDS INC I-37528	CIRCULATING PUMP	R	4/19/2019		207.51CR	112827	207.51
3097	MINNEOTA PUBLIC SCHOOL I-201904163396	MN BASEBALL TOURNAMENT	R	4/19/2019		100.00CR	112828	100.00
1757	MN CHILD SUPPORT PAYMENT CENTER I-C12201904173404	#0014992937	R	4/19/2019		356.25CR	112829	356.25
5610	MN DEPT EMPLOYMENT & ECONOMIC DEVELOPMENT I-12641360	.	R	4/19/2019		137.84CR	112830	137.84
1813	MN POLLUTION CONTROL AGENCY I-10000069347	2019 PERMIT FEE	R	4/19/2019		5,900.00CR	112831	5,900.00
5857	MORRIS ELECTRONICS I-20151642	IT CONSULTATION	R	4/19/2019		80.00CR	112832	80.00
5724	MOTION PICTURE LICENSING CORP I-504211092	LICENSE 06/19-06/20	R	4/19/2019		336.91CR	112833	336.91
6380	MWOA LAB WORKSHOP I-201904173402	LAB WORKSHOP	R	4/19/2019		125.00CR	112834	125.00

VENDOR	NAME / I.D.	DESC	CHECK TYPE	CHECK DATE	DISCOUNT	AMOUNT	CHECK NO#	CHECK AMOUNT
1945	NORMS GTC							
	I-7480-93242	OSHKOSH PLOW	R	4/19/2019		57.97CR	112835	
	I-7480-93443	POWER STEERING FLUID	R	4/19/2019		87.96CR	112835	145.93
5461	NOTE GALLERY							
	I-201904173406	HELP WITH GUITAR CLASS	R	4/19/2019		105.00CR	112836	105.00
3809	O'REILLY AUTOMOTIVE STORES, INC							
	I-1538-196976	FILTER	R	4/19/2019		22.04CR	112837	22.04
2027	PERA OF MINNESOTA							
	I-129614	M LARSEN	R	4/19/2019		405.27CR	112838	405.27
2036	PHILLIPS WINE AND SPIRITS INC							
	C-326637	.	R	4/19/2019		110.75	112839	
	C-326638	.	R	4/19/2019		42.67	112839	
	I-2535795	.	R	4/19/2019		7,369.43CR	112839	
	I-2535796	.	R	4/19/2019		2,466.77CR	112839	9,682.78
2064	POWERPLAN							
	I-P59270	JD 770 BLADE	R	4/19/2019		91.80CR	112840	91.80
1533	PRAIRIE PRIDE COOPERATIVE							
	I-120975	#2 DIESEL ROAD TANK	R	4/19/2019		2,231.20CR	112841	2,231.20
2096	QUARNSTROM & DOERING, PA							
	I-M007-053,S71664	PKWY II -SWALBOSKI	R	4/19/2019		393.75CR	112842	
	I-M1951-100,S71667	MARSHALL HOTEL	R	4/19/2019		68.00CR	112842	461.75
2143	THOOFT ENTERPRISES LLC							
	I-4292	FURNACE CHECK	R	4/19/2019		65.00CR	112843	65.00
2201	RUNNINGS SUPPLY INC							
	I-4614823	SHOVELS/PLOW SHACKLES	R	4/19/2019		49.92CR	112844	
	I-4618170	SUPPLIES	R	4/19/2019		11.99CR	112844	61.91
4855	SOUTHERN GLAZER'S OF MN							
	I-1806792	.	R	4/19/2019		3.60CR	112845	
	I-1806793	.	R	4/19/2019		2,968.33CR	112845	
	I-1806794	..	R	4/19/2019		963.20CR	112845	
	I-5040996	.	R	4/19/2019		8,904.60CR	112845	12,839.73

VENDOR	NAME / I.D.	DESC	CHECK TYPE	CHECK DATE	DISCOUNT	AMOUNT	CHECK NO#	CHECK AMOUNT
2311	SOUTHWEST GLASS CENTER							
	I-103481	RESET LOCK CODE	R	4/19/2019		55.00CR	112846	
	I-103551	BLDG REPAIR	R	4/19/2019		333.00CR	112846	
	I-2311	DOOR LOCK REPAIR	R	4/19/2019		272.50CR	112846	660.50
2318	SOUTHWEST SANITATION INC.							
	I-201904163397	03/19 SVC	R	4/19/2019		13.10CR	112847	13.10
0147	TAHER FOOD SERVICE							
	I-1100	ASP SNACKS	R	4/19/2019		65.70CR	112848	65.70
5023	US GEOLOGICAL SURVEY							
	I-90717285	RDWD GAGING Q2 2019	R	4/19/2019		2,112.50CR	112849	2,112.50
5733	VAST BROADBAND							
	I-001744201-0419	04/06-05/05/19	R	4/19/2019		347.66CR	112850	
	I-002685901-0419	04/08-05/07/19	R	4/19/2019		88.04CR	112850	
	I-002687201-0419	04/08-05/07/19	R	4/19/2019		113.54CR	112850	
	I-005489701-0419	04/08-05/07/19	R	4/19/2019		106.95CR	112850	
	I-015038501-0419	04/08-05/07/19	R	4/19/2019		61.94CR	112850	
	I-015038601-0419	04/06-05/05/19	R	4/19/2019		59.13CR	112850	
	I-015044201-0419	04/06-05/05/19	R	4/19/2019		116.90CR	112850	
	I-015082101-0419	04/06-05/05/19	R	4/19/2019		285.33CR	112850	
	I-015187301-0419	04/06-05/05/19	R	4/19/2019		420.40CR	112850	
	I-015429901-0419	03/30-04/29/19	R	4/19/2019		180.08CR	112850	
	I-015511601-0419	04/10-05/09/19	R	4/19/2019		195.79CR	112850	
	I-015790801-0419	04/06-05/05/19	R	4/19/2019		13.53CR	112850	1,989.29
VOID	VOID CHECK		V	4/19/2019			112851	**VOID**
4489	VERIZON WIRELESS							
	I-9826758381	02/24-03/23/19	R	4/19/2019		35.01CR	112852	
	I-9827284705	03/02-04/01/19	R	4/19/2019		49.04CR	112852	
	I-9827748652	03/09-04/08/19	R	4/19/2019		480.18CR	112852	564.23
2583	WEST CENTRAL FIREFIGHTERS ASSOCIATION							
	I-201904163398	2019 DUES	R	4/19/2019		55.00CR	112853	55.00
5237	YOUNGSMA, LUCAS							
	I-201904163399	REIMBURSE FOR COMPUTER MOUNTIN	R	4/19/2019		138.03CR	112854	138.03

* * T O T A L S * *	NO#	DISCOUNTS	CHECK AMT	TOTAL APPLIED
REGULAR CHECKS:	67	0.00	149,181.30	149,181.30
HANDWRITTEN CHECKS:	0	0.00	0.00	0.00
PRE-WRITE CHECKS:	0	0.00	0.00	0.00
DRAFTS:	0	0.00	0.00	0.00
VOID CHECKS:	2	0.00	0.00	0.00
NON CHECKS:	0	0.00	0.00	0.00
CORRECTIONS:	0	0.00	0.00	0.00
REGISTER TOTALS:	69	0.00	149,181.30	149,181.30

TOTAL ERRORS: 0 TOTAL WARNINGS: 0

VENDOR	NAME / I.D.	DESC	CHECK TYPE	CHECK DATE	DISCOUNT	AMOUNT	CHECK NO#	CHECK AMOUNT
--------	-------------	------	---------------	---------------	----------	--------	--------------	-----------------

** POSTING PERIOD RECAP **

FUND	PERIOD	AMOUNT
101	4/2019	58,477.74CR
206	4/2019	393.75CR
211	4/2019	43.24CR
230	4/2019	288.00CR
258	4/2019	243.17CR
260	4/2019	450.00CR
270	4/2019	164.85CR
493	4/2019	50.00CR
494	4/2019	16,736.94CR
495	4/2019	68.00CR
602	4/2019	10,436.52CR
609	4/2019	59,498.97CR
630	4/2019	2,330.12CR
=====		
ALL		149,181.30CR



CITY OF MARSHALL AGENDA ITEM REPORT

Meeting Date:	Tuesday, April 23, 2019
Category:	NEW BUSINESS
Type:	INFO/ACTION
Subject:	Introduce the request for map amendment (rezone) of James Carr, Marshall, MN, at 701, 703, 705, 800, 801, 802, 803, 804, 805, 806, 807, 900, 901, 902, 903, 904 and 905 Andrew Street.
Background Information:	<p>This is a request by James Carr, Marshall, MN to rezone properties at 701, 703, 705, 800, 801, 802, 803, 804, 805, 806, 807, 900, 901, 902, 903, 904 and 905 Andrew Street from R-1 One Family Residential District to R-2 One to Four Family Residential District.</p> <p>To permit construction of tri-plex structures, as the owner desires, the lots must be rezoned to an R-2 One to Four Family Residential District. The adjacent land south of the zoning area is zoned R-2 One to Four Family Residential District.</p> <p>Rezoning procedures are described in Section 86-30 Amendments https://library.municode.com/mn/marshall/codes/code_of_ordinances?nodetd=PTIICOOR_CH86ZO_ARTIADEN_DIV1GE_S86-30AM. Attached are an aerial photo, and rezoned area extent for your reference.</p> <p>At the April 10, 2019, Planning Commission meeting, a public hearing was held, and a motion was made by Carstens, second by Steen to recommend approval to City Council to rezone the property as recommended by staff. Motion passed Fox abstained. Planning Commission minutes are attached under the “Information Only” agenda item.</p>
Fiscal Impact:	Costs are to be billed to applicant.
Alternative/Variations:	None recommended.
Recommendations:	that the Council introduce the attached ordinance to rezone 701, 703, 705, 800, 801, 802, 803, 804, 805, 806, 807, 900, 901, 902, 903, 904 and 905 Andrew Street from R-1 One Family Residential District to R-2 One to Four Family Residential District.

ORDINANCE NUMBER _____, SECOND SERIES

**ORDINANCE AMENDING CHAPTER 86
OF THE CITY CODE RELATING TO ZONING**

The Common Council of the City of Marshall does ordain as follows:

Section 1. Chapter 86 of the City Code and the City of Marshall Zoning Map referred to in Section 86-72, are hereby further amended as follows, to- wit:

**City of Marshall, County of Lyon, State of Minnesota
701, 703, 705, 800, 801, 802, 803, 804, 805, 806, 807, 900, 901, 902, 903, 904
and 905 Andrew Street
Lots 2, 3, 4, 5, 6, 7, 8, 9, 10 Block 3 Carr Subdivision 1 and Lots 14, 15, 16, 17, 18, 19, 20
Block 2 Carr Subdivision 1 and Lot 3 Block 1 Carr Subdivision II**

is hereby rezoned from R-1 One Family Residential District to R-2 One to Four Family Residential District.

Section 2. Within thirty (30) days after official publication of the Ordinance, the Zoning Administrator of said City is directed to record on the City of Marshall Zoning Map, the changes in zoning resulting from the passage of this ordinance.

Section 3. Except as amended herein, said Chapter 86, as heretofore amended, shall remain in full force and effect.

Section 4. This Ordinance shall take effect from and after its passage and publication.

Passed and adopted by the Common Council this 14th day of May, 2019.

THE COMMON COUNCIL

ATTEST:

Mayor of the City of Marshall, MN

City Clerk

This Instrument Drafted by:
Glenn J. Olson, P.E.
Director of Public Works/City Engineer

Introduced on: April 23, 2019

Final Passage on: May 14, 2019

Published in the Official Newspaper : _____

CONNECTExplorer

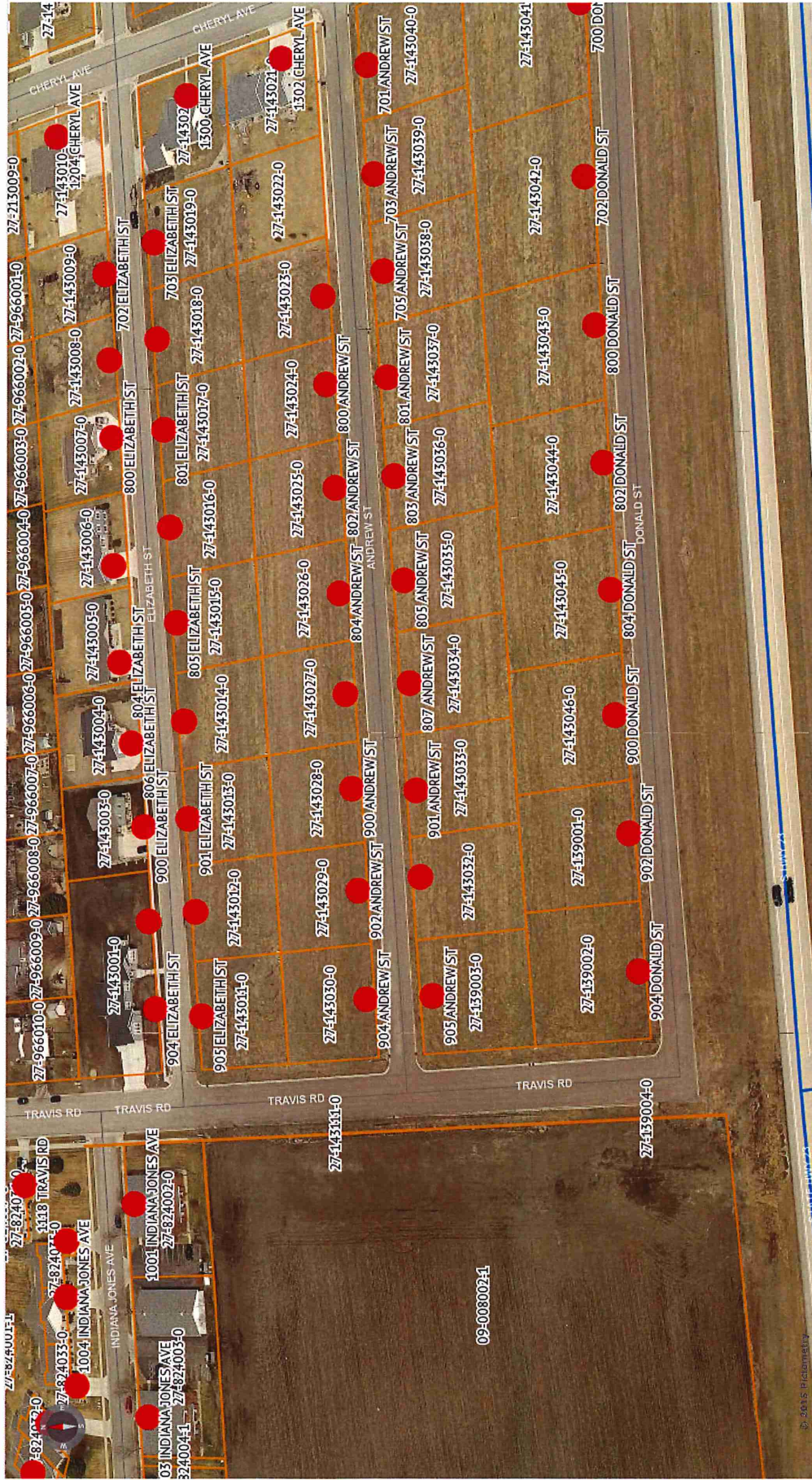

map: Auto (Oblique) Mar 2015 - Apr 2015 image 1 of 8 03/27/2015

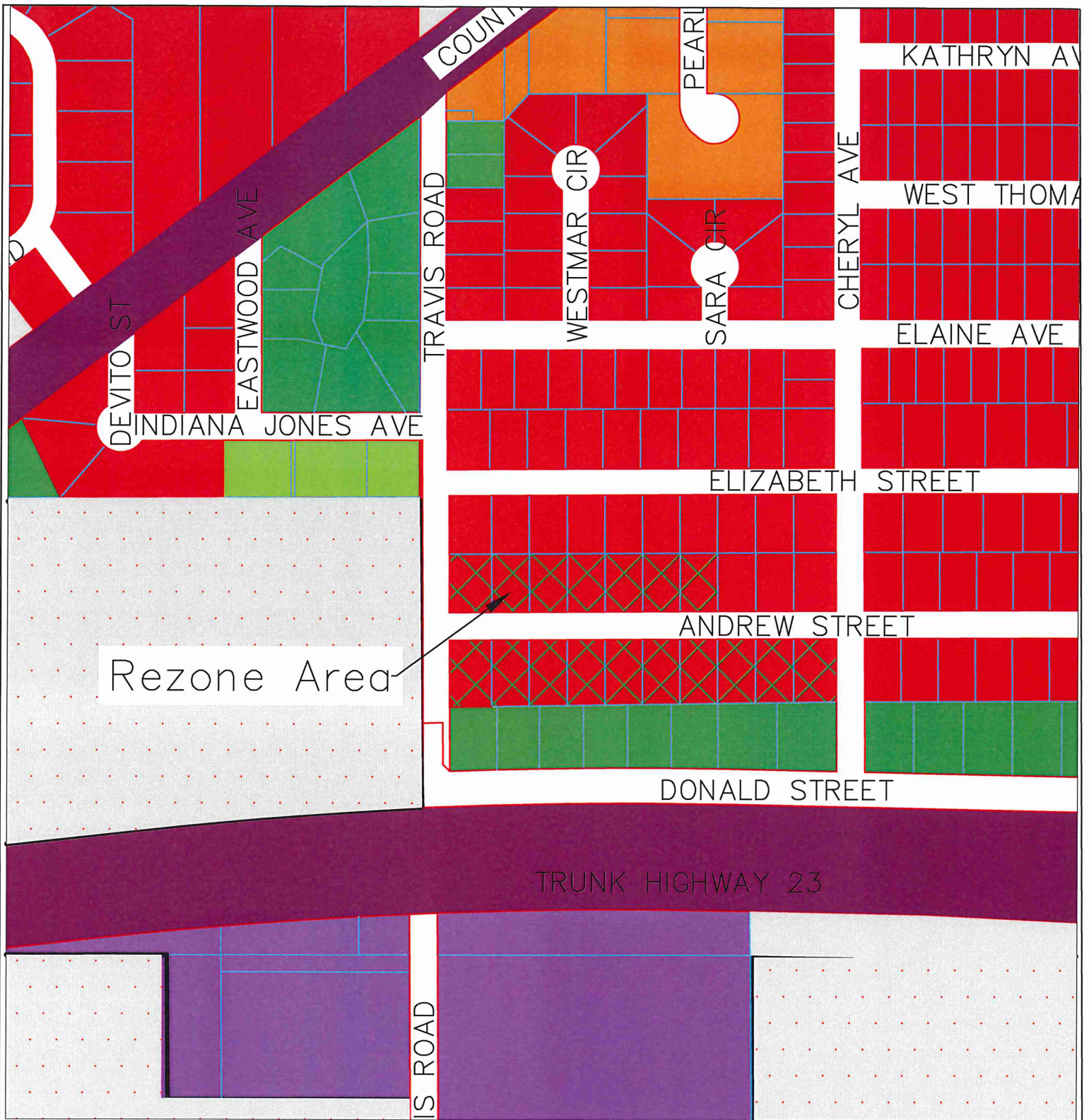

A		AGRICULTURAL	R-4		HIGHER DENSITY - MULTIPLE FAMILY RESIDENCE	B-3		GENERAL BUSINESS
R-1		ONE FAMILY RESIDENCE	R-5		MANUFACTURED HOME PARK	B-4		SHOPPING CENTER BUSINESS
R-2		ONE TO FOUR FAMILY RESIDENCE	B-1		LIMITED BUSINESS	I-1		LIMITED INDUSTRIAL
R-3		LOW TO MEDIUM DENSITY - MULTIPLE FAMILY RESIDENCE	B-2		CENTRAL BUSINESS	I-2		GENERAL INDUSTRIAL



COMMUNITY PLANNING DEPT.
344 WEST MAIN STREET
MARSHALL, MINNESOTA
56258

CARR SUBDIVISION I REZONE

APRIL 3, 2019

EXISTING ZONING MAP W/ PROPOSED REZONE AREA FROM R-1 TO R-2



CITY OF MARSHALL AGENDA ITEM REPORT

Meeting Date:	Tuesday, April 23, 2019
Category:	NEW BUSINESS
Type:	INFO/ACTION
Subject:	Request for map amendment (rezone) 1213, 1215 and 1217 West Main Street.
Background Information:	<p>This is a request by Douglas and Peggy Anderson, Marshall, MN to rezone properties at 1213, 1215 and 1217 West Main Street from B-3 General Business District to a I-2 General Industrial District. The owner intends to build an addition to his building (Marshall Machine Shop); that addition will be built on the north side and will extend into the lots along West Main Street. The use of the building is manufacturing, and it is not permitted in a B-3 General Business District, which the three lots to be rezoned currently are. To permit building an addition, they must be rezoned to an I-2 General Industrial District.</p> <p>The adjacent land south of these lots is presently zoned I-2 General Industrial District and the land across Main Street is zoned I-1 Limited Industrial District, so the requested rezoning is consistent with the zoning of surrounding areas. However, the 1996 City Comprehensive plan shows the corridor along Main Street as a commercial use rather than industrial. Nevertheless, the staff's opinion is that at this time the requested change is acceptable considering the age of the Comprehensive plan, the use of the neighboring properties and the location of major commercial development areas within the city.</p> <p>Rezoning procedures are described in Section 86-30 Amendments https://library.municode.com/mn/marshall/codes/code_of_ordinances?nodeId=PTIICOOR_CH86ZO_ARTIADEN_DIVIGE_S86-30AM. Attached are an aerial photo, and rezoned area extent for your reference.</p> <p>At the March 13, 2019, Planning Commission meeting, a public hearing was held, and a motion was made by Carstens, second by Ruud to recommend approval to City Council to rezone the property as recommended by staff. All voted in favor.</p> <p>The Ordinance Amendment to rezone 1213, 1215 and 1217 West Main Street from B-3 General Business District to I-2 General Industrial District was introduced at the March 26, 2019, City Council meeting.</p>
Fiscal Impact:	Costs are to be billed to applicant.
Alternative/Variations:	None recommended.
Recommendations:	that the Council adopt Ordinance Number XXX, Second Series to rezone 1213, 1215 and 1217 West Main Street from B-3 General Business District to I-2 General Industrial District.

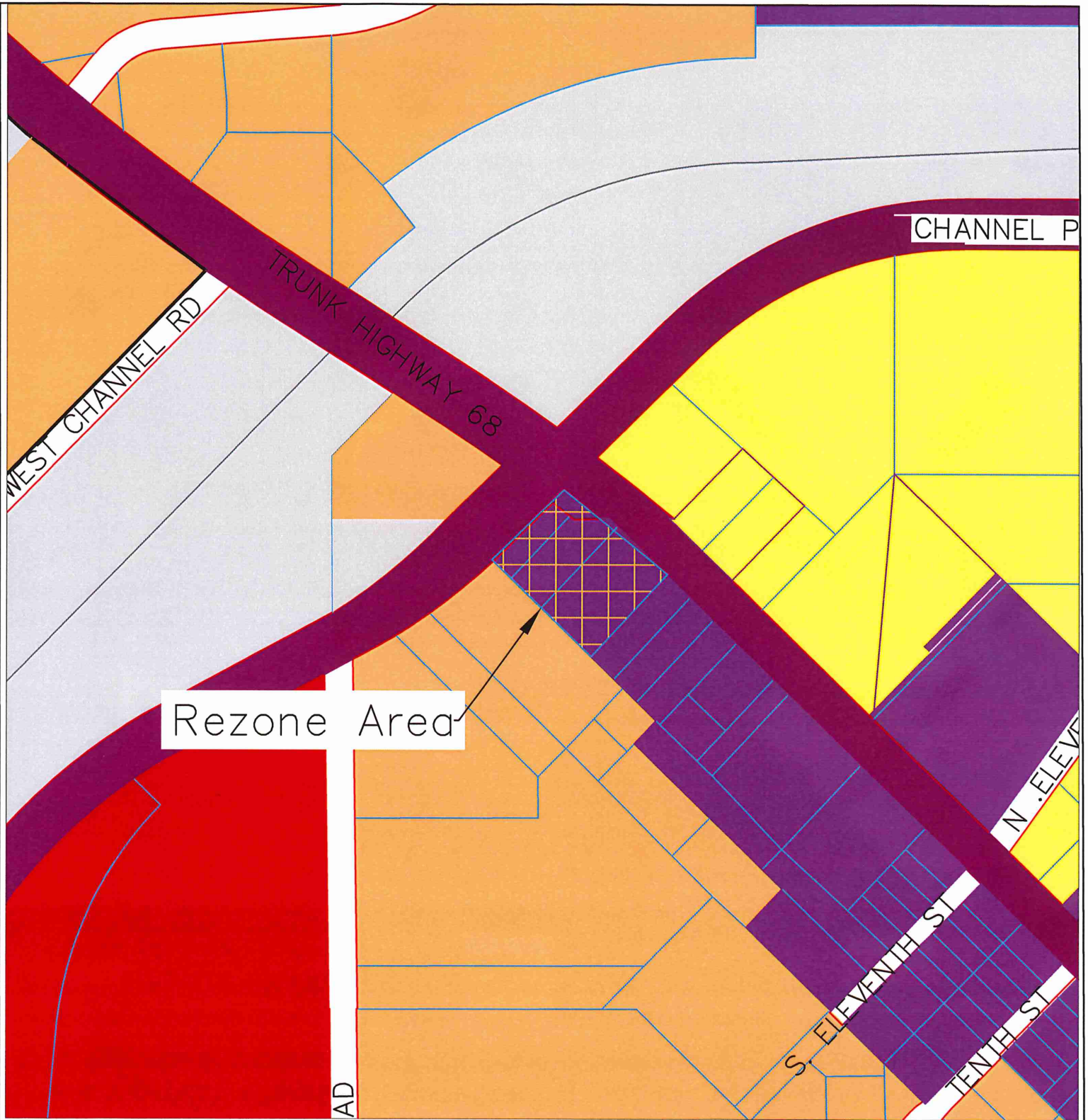

A		AGRICULTURAL	R-4		HIGHER DENSITY - MULTIPLE FAMILY RESIDENCE	B-3		GENERAL BUSINESS
R-1		ONE FAMILY RESIDENCE	R-5		MANUFACTURED HOME PARK	B-4		SHOPPING CENTER BUSINESS
R-2		ONE TO FOUR FAMILY RESIDENCE	B-1		LIMITED BUSINESS	I-1		LIMITED INDUSTRIAL
R-3		LOW TO MEDIUM DENSITY - MULTIPLE FAMILY RESIDENCE	B-2		CENTRAL BUSINESS	I-2		GENERAL INDUSTRIAL



COMMUNITY PLANNING DEPT.
344 WEST MAIN STREET
MARSHALL, MINNESOTA
56258

ANDERSON PROPERTY REZONE

MARCH 6, 2019

EXISTING ZONING MAP W/ PROPOSED REZONE AREA FROM B-3 TO I-2

CONNECTEXPLORER

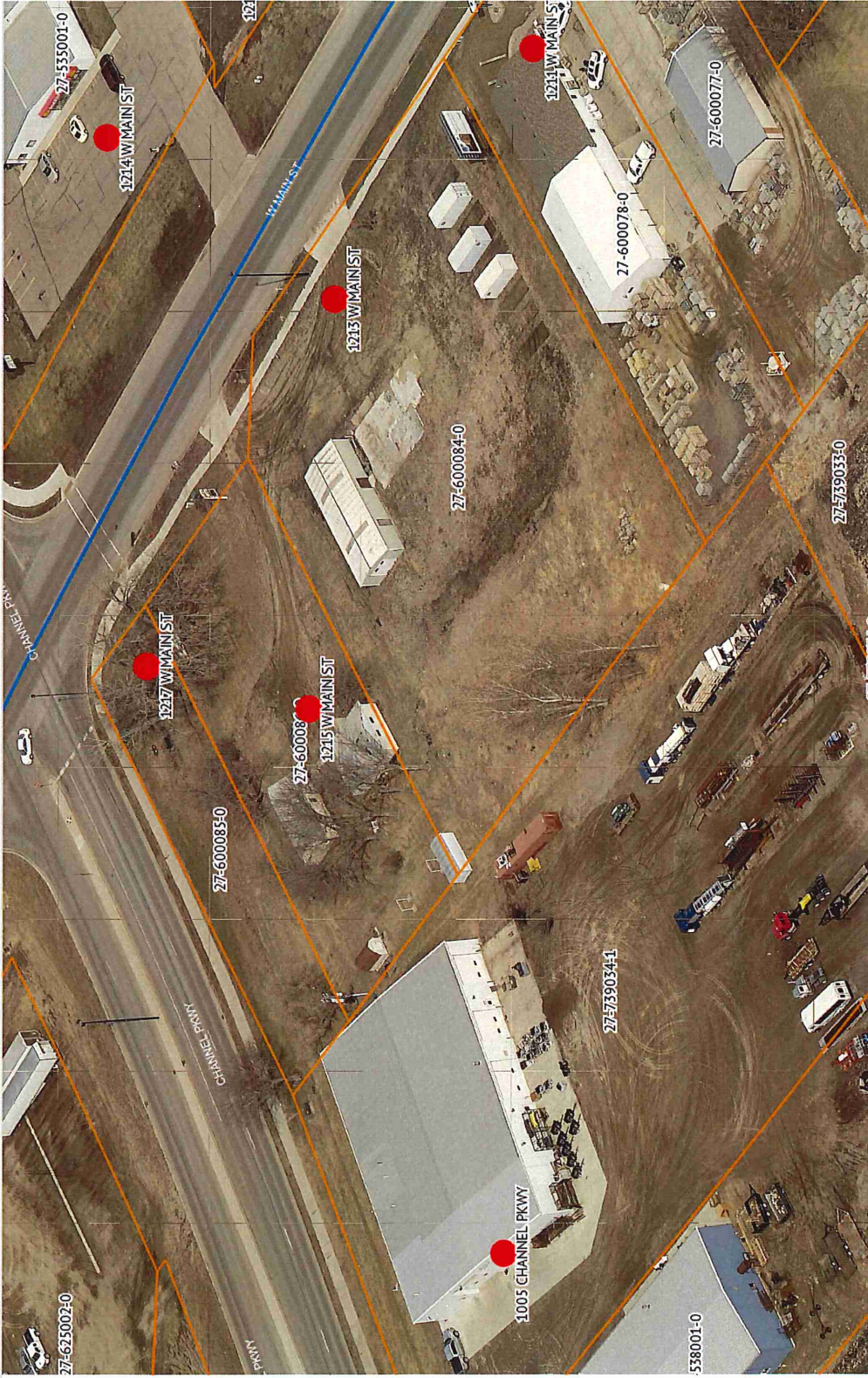

© 2015 Pictometry

map: Auto (Oblique) Mar 2015 - Apr 2015 image 1 of 11 03/27/2015

ORDINANCE NUMBER _____, SECOND SERIES

**ORDINANCE AMENDING CHAPTER 86
OF THE CITY CODE RELATING TO ZONING**

The Common Council of the City of Marshall does ordain as follows:

Section 1. Chapter 86 of the City Code and the City of Marshall Zoning Map referred to in Section 86-72, are hereby further amended as follows, to- wit:

**City of Marshall, County of Lyon, State of Minnesota
1213, 1215 and 1217 West Main Street
See Exhibit A**

is hereby rezoned from B-3 General Business District to I-2 General Industrial District.

Section 2. Within thirty (30) days after official publication of the Ordinance, the Zoning Administrator of said City is directed to record on the City of Marshall Zoning Map, the changes in zoning resulting from the passage of this ordinance.

Section 3. Except as amended herein, said Chapter 86, as heretofore amended, shall remain in full force and effect.

Section 4. This Ordinance shall take effect from and after its passage and publication.

Passed and adopted by the Common Council this 23th day of April, 2019.

THE COMMON COUNCIL

ATTEST:

Mayor of the City of Marshall, MN

City Clerk

This Instrument Drafted by:
Glenn J. Olson, P.E.
Director of Public Works/City Engineer

Introduced on: March 26, 2019

Final Passage on: April 23, 2019

Published in the Official Newspaper : _____



CITY OF MARSHALL AGENDA ITEM REPORT

Meeting Date:	Tuesday, April 23, 2019
Category:	NEW BUSINESS
Type:	ACTION
Subject:	Legion Field Stormwater Study - Report Update from Bolton & Menk, Inc.
Background Information:	<p>At the September 25, 2018 meeting, the City Council authorized entering a professional services agreement for Legion Field Road Stormwater Study with Bolton & Menk, Inc.</p> <p>The study proposed drainage improvements for the industrial and residential areas north of West College Drive and west of Legion Field Road and for the residential area east of Legion Field Road and generally north of the BNSF Railway, including Parkway III.</p> <p>Josh Stier of Bolton & Menk, Inc., the City's consultant will present the attached powerpoint relating to the study.</p>
Fiscal Impact:	None at this time.
Alternative/ Variations:	No alternative actions.
Recommendations:	Information only.



Real People. Real Solutions.

Legion Field Road Stormwater Study

City of Marshall April 23, 2019

Josh Stier, P.E.



Photo by (Resident) Karin Elton



Existing Conditions



Map Document: H:\MARSH\M18117079\CISE\ExistingConditions.mxd | Date Saved: 3/20/2019 4:10:16 PM

Existing Conditions

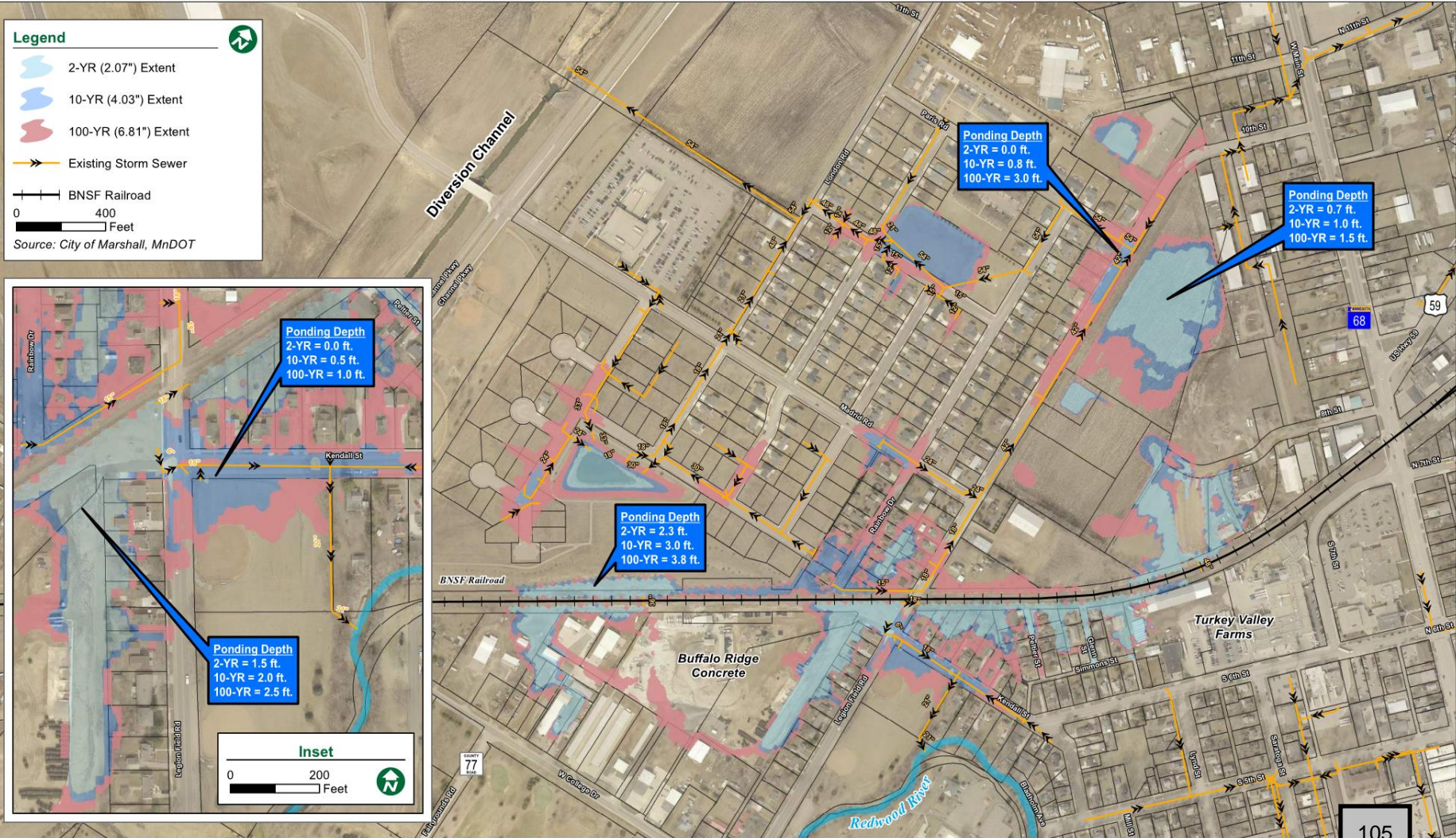

Map Document: H:\MARS\M1817076\GIS\ES\ExistingInundation.mxd | Date Saved: 3/20/2019 4:15:28 PM

Phase I Improvements

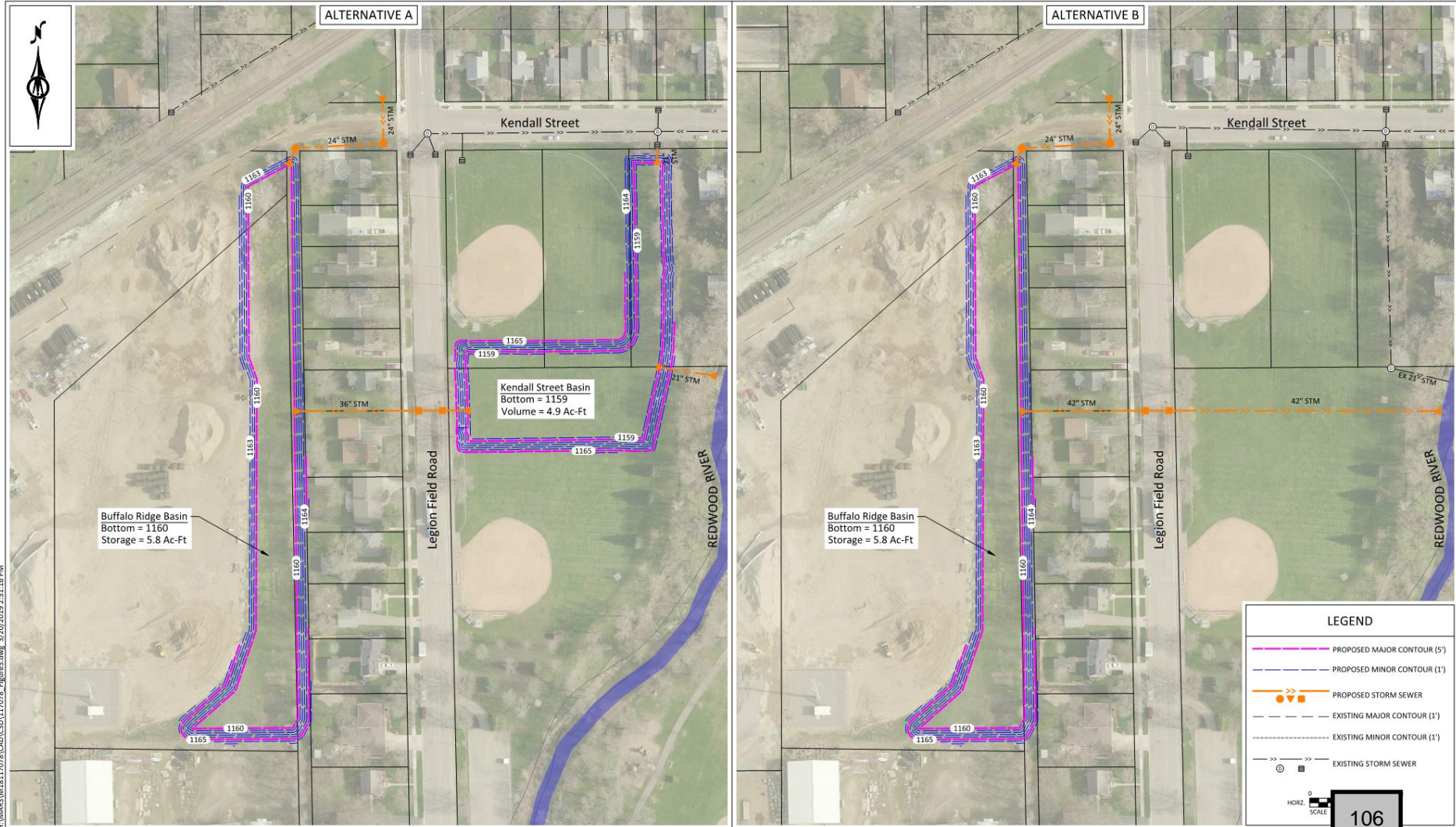

H:\MARSH\M1817078\CA\CD\CD\117078_Figures.dwg_3/20/2019 2:31:16 PM

Phase II Improvements

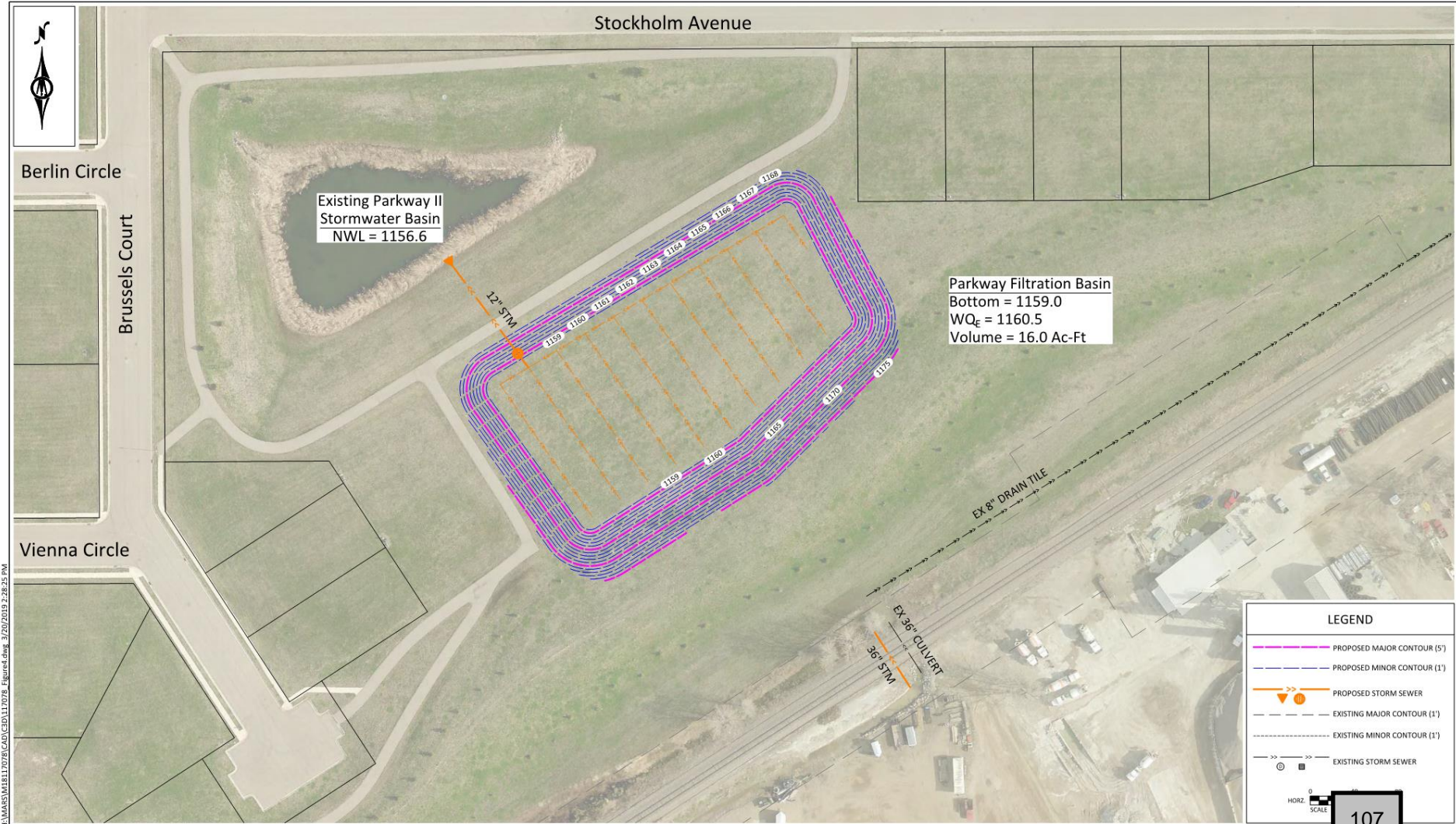

H:\MMS\117078\CAD\CID\117078_Figure4.dwg 3/20/2019 2:28:25 PM

Phase III Improvements



Legion Field Road Stormwater Study
City of Marshall, MN

Figure 5: Proposed Phase 3
March 2019

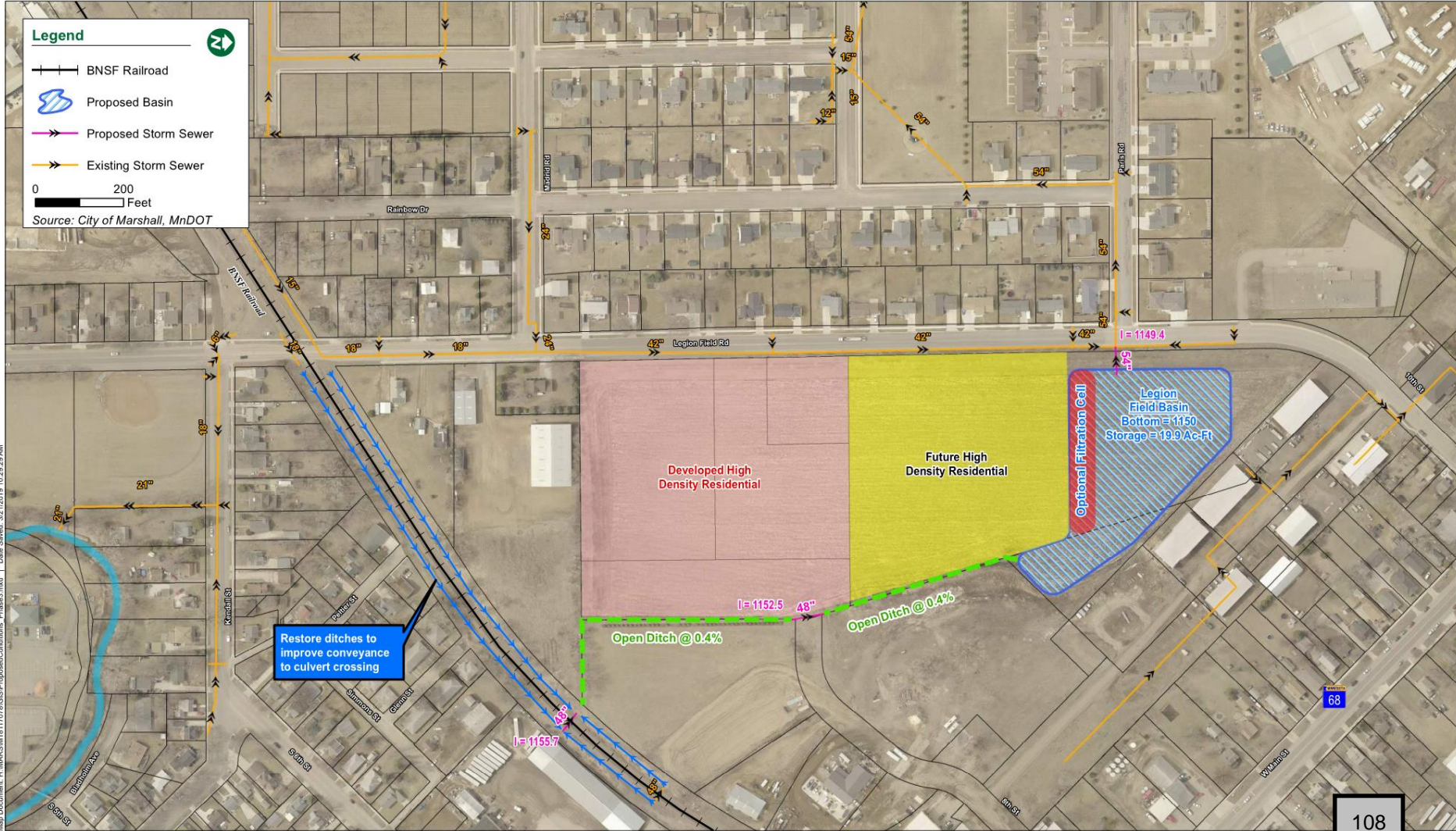

Map Document: H:\MARS\M1817076\GIS\ProposedConditions_Phase3.mxd | Date Saved: 3/21/2019 10:29:29 AM

Estimated Cost

- Phase I: Buffalo Ridge Basin
 - = \$405,000
- Phase II: Parkway Filtration Basin
 - = \$460,000
- Phase III: Legion Field Basin
 - = \$584,000
- Total Cost = \$1.45 Million

*Costs do not include temporary and permanent easement

Legion Field Road Stormwater Study Questions and Comments



Photo by (Resident) Karin Elton





CITY OF MARSHALL AGENDA ITEM REPORT

Meeting Date:	Tuesday, April 23, 2019
Category:	NEW BUSINESS
Type:	INFO
Subject:	2018 Marshall Area EDA Annual Report
Background Information:	Director of Economic Development Tara Onken will present the 2018 Annual Economic Development Authority Report
Fiscal Impact:	
Alternative/ Variations:	
Recommendations:	Information Only

MARSHALL AREA EDA ANNUAL REPORT

2018



TABLE OF CONTENTS

EDA PRESIDENT MESSAGE.....	3
EDA STAFF & BOARD OF DIRECTORS.....	3
FINANCIAL SUMMARY.....	4
ECONOMIC TRENDS ANALYSIS.....	5
Marshall Area Businesses	6
Business Development	7
Building Permit Activity	12
Local Sales & Use Tax	16
RETAIL TRADE ANALYSIS.....	17
Merchandise Category	18
Pull Factor	19
DEMOGRAPHIC ANALYSIS.....	20
Population Trends	21
Age & Gender Distribution	21
Household Income	22
Poverty Level	22
WORKFORCE ANALYSIS.....	23
Unemployment Rate	24
Industry Employment	24
Employment Occupation	25
Household Earnings	25
Job Vacancies	26
Regional Employment Projections	27
Major Employers	28
Commuting Patterns	29
EDUCATIONAL ANALYSIS.....	30
Educational Attainment	31
School Enrollment	31
Marshall Public Schools	32
Southwest Minnesota State University	33
HOUSING ANALYSIS.....	34
Housing Characteristics	35
Affordable Housing	36
Wages & Affordability	36
DEVELOPMENT OPPORTUNITIES.....	37
DISCOVER SOUTHWEST MN PARTNERSHIP.....	43
Lyon County Stats.....	48
Achievements.....	49

MARSHALL EDA

EDA PRESIDENT MESSAGE

Merriam-Webster defines progress as “gradual betterment” or “to move forward.” In 2018, Marshall experienced significant progress with the additional development at the MERIT Center, the addition of Aldi to Marshall’s grocery offerings, the Menards and Grace Life Church expansions and ongoing redevelopment at Furniture Mart USA. Renovations by several local restaurants, a resurgence in Marshall’s downtown area with the opening of several small businesses, the start of construction of a new apartment complex in Marshall’s Parkway III Addition, and the readying of parcels along East College Drive for future development enhances the economic vitality of the Marshall area. In the greater Marshall area, trū Shrimp Company completed a state-of-the-art expansion of its campus in Balaton, Meadowland Farmers Co-op opened a new agronomy center in Russell, Chasing Our Tails expanded its organization from New Hampshire into Tracy, and Dollar General has expanded into Minnesota. Our progress is the result of the efforts of many and provides opportunities for many, making Marshall stronger as a regional leader. Thank you to all who have contributed to the growth and progress in Marshall and the neighboring communities. We are becoming stronger together!

*Greg Bucher,
EDA President*



Sharon Hanson

EDA EXECUTIVE DIRECTOR
(507) 537-6760
sharon.hanson@ci.marshall.mn.us



Tara Onken

EDA DIRECTOR
(507) 337-0802
tara.onken@marshallmn.org



Marcia Loeslie

ASSISTANT EDA DIRECTOR
marcia.loeslie@ci.marshall.mn.us

EDA Board of Directors



Greg Bucher – President
Chet Lockwood - Vice President
Randy Serreyn -Treasurer
Stacy Frost
John DeCramer
Steven Meister
Dan Herrmann

FINANCIAL SUMMARY

	BEGINNING FUND BALANCE 1/1/18	ENDING FUND BALANCE 12/31/18
FUND 204 <i>LOCAL EDA CRIF</i>	559,547.71	556,776.36
FUND 205 <i>PARKWAY ADDITION</i>	219,460.12	219,205.71
FUND 206 <i>PARKWAY ADDITION II</i>	(641,787.57)	(18,811.08)
FUND 207 <i>PARKWAY ADDITION III & IV</i>	1,123,587.57	1,295,789.86
FUND 208 <i>EDA ADMIN</i>	65,609.11	54,707.51
FUND 212 <i>STATE EDA CRIF</i>	316,270.88	-
FUND 213 <i>FEDERAL EDA CRIF</i>	957,184.16	173,252.56
FUND 214 <i>EDA REVOLVING</i>	-	255,259.93
TOTAL	\$2,599,871.98	\$2,558,180.85



ECONOMIC TRENDS ANALYSIS

Marshall is a regional center for medical care, retail, trade, education, employment and business. The diverse economic base and strong foundation in agriculture has provided stability to the local economy over recent years. Recent studies illustrate a common labor and retail draw from approximately 40 miles from City. Marshall's current population of 13,710 doubles it's daytime population of 25,000 according to employment estimates.

116

AREA BUSINESSES

NEW BUSINESSES

- Elysian Chiropractic
- Anavah Consulting
- North Central Reforestation
- Coleman Management
- MG Home Inspections
- The Gym of Marshall
- Southwest Pest Pros
- Deutz Heritage Farm
- Evolution of Beauty
- Nettie's
- Nessa's Naturals
- Ali J Boutique
- Lynn Van Patten Yoga
- Highway 23 Storage
- Ton Kau Asian Grocery Store
- Aldi Corp
- ABC Daycare
- Deutz Brothers

RENAMED BUSINESSES

- H&L Orthodontics PLLC (Formerly Lecy Orthodontics)
- Main-Stay Cafe (Formerly The Daily Grind)
- North Risk Partners (Formerly Midwest United Insurance)
- AgCountry Farm Credit Services (Formerly United FCS)
- North Central International (Formerly Olson & Johnson)

CLOSED BUSINESSES

- Marshall Yoga Shala
- Literacy Volunteers of SW MN
- Duane Anderson Chartered
- Masterson Staffing
- BusinessWare Solutions
- Affiliated Community Medical Center (ACMC)
- Midwest Wellness Institute
- Mid-Continent Cabinetry

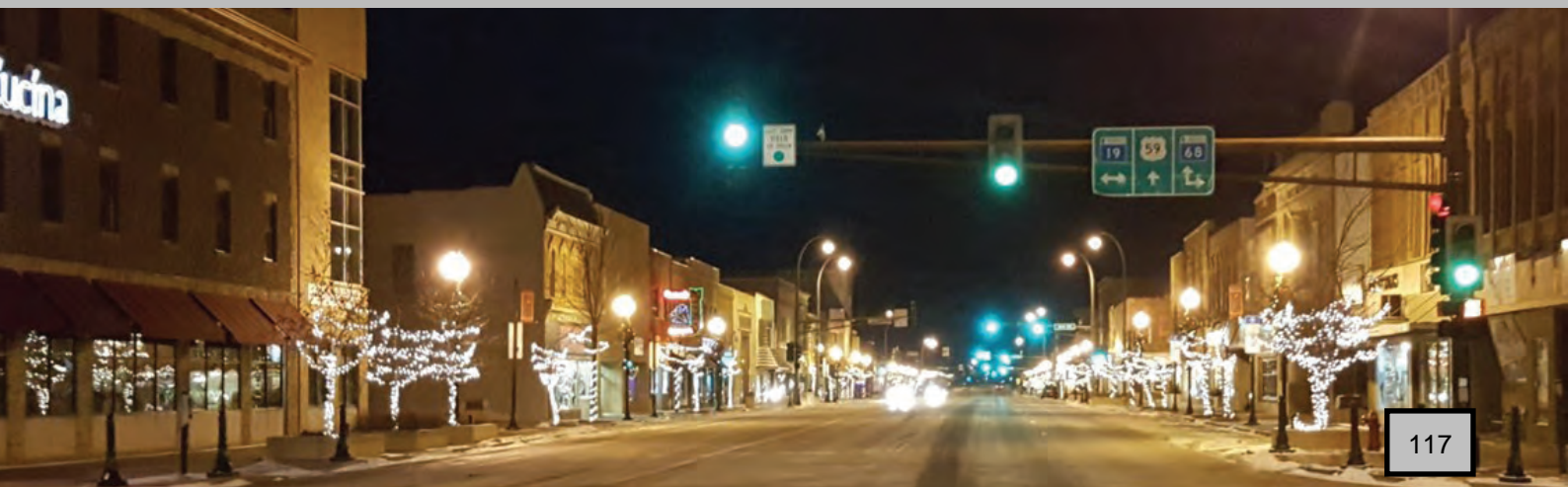

BUSINESS DEVELOPMENT



MERIT CENTER

The second phase of construction of the MERIT Center driving track broke ground at the end of October 2018. A bonding package approved by the Minnesota House of Representatives includes a \$3 million appropriation for the Minnesota Emergency Response and Industrial Training (MERIT) Center in Marshall. The project will add 1.5 miles of road, which will expand the types of training that can be done on the track.

AVERA - ACOMC ACQUISITION

Avera Marshall purchased Affiliated Community Medical Center after being sold to Carris Health. The 150 employees of Carris Health in Marshall became Avera employees. Avera Medical Group physicians and advanced practice providers (APPs) in the Marshall region now exceed 100.

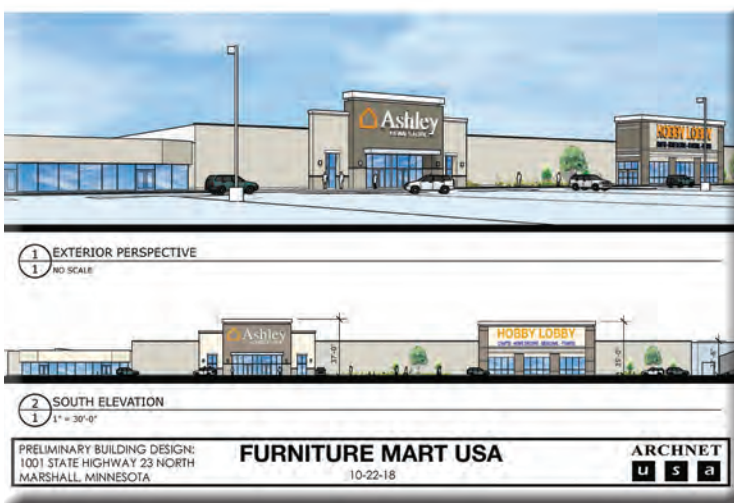

FURNITURE MART USA ASHLEY HOMESTORE

Furniture Mart has redeveloped the old K-mart building as a multi-tenant building, including a future Ashley HomeStore, among others to be announced.

UNIQUE OPPORTUNITIES

Unique Opportunities purchased 9 acres of Parkway III for up to a 107-unit apartment development project that could invest up to \$11 Million in the area. The first 36 unit building is currently underway. Amenities include stainless steel appliances, granite counter-tops, washers and dryers in each apartment.

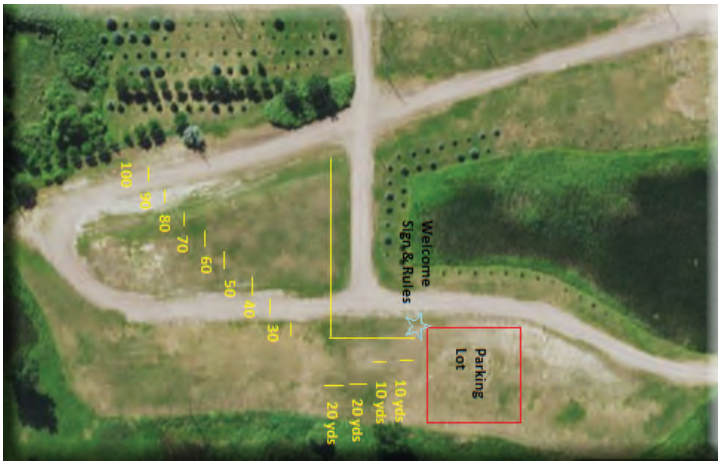

MARSHALL AREA PUBLIC ARCHERY RANGE

This archery range will be open to the public at no cost. The range targets will vary from 10 yards all the way out to 100 yards. The total cost of the project is estimated to be about \$8,500 and will offer a new recreational sporting option to residents of the Marshall area. It will be located adjacent to MERIT Center on Erie Road.



MENARDS

The Marshall expansion will include more product selection and displays, create more space for customer order pick-up for our growing online business, an additional warehouse in the outside lumberyard, expansion of the Garden Center, and a few changes to the store's interior.



GRACE LIFE/EAST SIDE CAMPUS EXPANSION

Grace Life Church Expansion was \$1.6 million. The addition is 15,000 SF, one story. The expansion includes an entryway, bathrooms, a coffee bar and a worship center, which is attached to the current building on the north side.



ALDI

Aldi Corp opened November 30th, 2018. This location has five aisles and 13,000 sq. ft. of retail space. The building permit was for \$2 Million dollars.



EDWARD JONES BUILDING

A newly constructed building on East College Drive is home to the new Edward Jones-Mike Leary. Two additional brand new office suites are available for rent. One rental suite is 1,800 sq. ft. and the other rental suite is 2,000 sq. ft. The site has ample parking and great visibility for a new or growing business.

COMMUNITY DEVELOPMENT



RED BARON USAGE

In 2018, the Red Baron Arena & Expo was in use for more than 3,500 hours, 953 of which were meetings, private parties, and public events. The Arena hosted 15 expos and community events this year along with 7 multi-day hockey tournaments, bringing approximately 1,500 hockey players to Marshall. The Red Baron Arena & Expo helps the community generate revenue through hotel stays, dining, and local shopping.

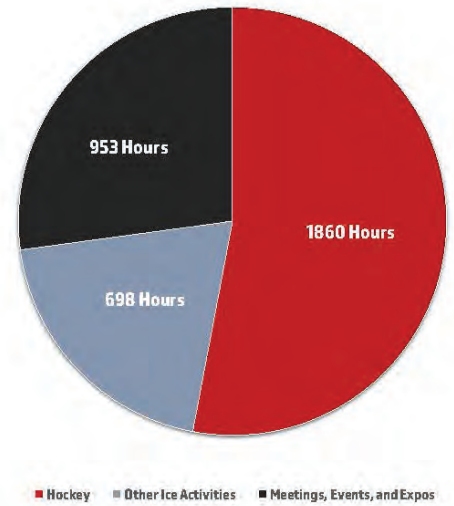

ELYSIAN CHIROPRACTIC

Elysian Chiropractic is a new business and tenant in the remodeled former liquor store location. Elysian Chiropractic is a family and pediatric wellness office.



North Central Reforestation, Inc.

NORTH CENTRAL REFORESTATION

Formerly located in Evansville, MN, North Central Reforestation began the process of relocating the entire facility to Marshall, MN in the fall of 2018.. North Central Reforestation, Inc. specializes in growing containerized tree seedlings.



DEUTZ HERITAGE FARM

Deutz Heritage raises antibiotic-free outdoor pork, grass-fed Red Angus Beef, and, seasonally, free range chickens. Deutz Heritage Farms is licensed for retail sales of pork, beef, and other inspected meats. Deutz Heritage also provides the Marshall area with the area's first Farm to Table specialty meats delivery service, providing customers quality local meats delivered right to their door step.

BICYCLE FRIENDLY COMMUNITY

The League of American Bicyclists recognized Marshall, MN on December 6, 2018 with a Bronze Level Bicycle Friendly Community (BFC) award, joining 464 communities from across the country. Marshall was awarded for improving conditions for bicycling through investment in bicycling promotion, education programs, infrastructure and pro-bicycling policies. Mayor Bob Byrnes said, "Being recognized as one of 25 communities in the great state of Minnesota is reflective of the progressive nature of our community and their commitment to an enriched quality of life.

SCHWAN'S COMPANY SALE

The Schwans Food Company sold their Food Service Business to CJ Cheiljedang (CJ), of Seoul, South Korea. The sale included 80% of Schwan's and subsidiaries that focus on foods sold in retail stores, grocery stores and food-service venues. The sale will also include the company's manufacturing and logistics operations. However, the Schwan family will keep 20% ownership of the businesses being sold, as well as 100% ownership of Schwan's Home Service, Inc.

HIGHWAY 23 TRANSPORTATION

MnDOT started the construction project to build a reduced-conflict intersection or "j-turn" at the intersection of Highway 23 and Lyon Street in early August. A restricted turn lane is also being built at the intersection of Clarice Avenue and Highway 23. The project goals are lower speed, safety and access improvements while staying within budget.

SAFE ROUTES TO SCHOOL

Marshall was awarded the Safe Routes to School/Transportation Alternatives Grant for School Zone Speed Limits and Traffic Calming Signage with a total project cost of \$424,800, a federal award of \$339,840 and a local match of \$84,960.

DEMOLITION PROJECTS



MARSHALL BOWL DEMOLITION

The previous Marshall Bowl was demolished and is vacant land for redevelopment. 1417 E College Drive



TAWAKAL BUILDING DEMOLITION

The previous Tawakal Store building was demolished and is vacant land for redevelopment. 1213 E College Drive

RENOVATION PROJECTS



MIKE'S CAFE RENOVATION

Interior and exterior renovations were completed to Mike's Cafe.



THE GYM OF MARSHALL

The Gym of Marshall is a local, family-owned sports bar and grill. A full bar and menu is available.



HOLY REDEEMER SCHOOL RENOVATION

The Holy Redeemer Education Center project consisted of HVAC, all new windows, and bathroom remodeling for boys and for girls both upstairs and down.



HITCHING POST NEW PATIO

The Hitching Post built a new patio to create an enjoyable outdoor seating experience. The original Hitching Post has been serving Marshall and surrounding community 14 years.



3RD STREET & DOWNTOWN BUSINESSES

Coleman Management purchased multiple buildings from Greig-Gregerson Management and renovated multiple spaces to open new businesses.



- **ALI J BOUTIQUE:** An expansion of its original store located in New London, MN, now also open in Marshall, MN. Ali is excited to provide a women's clothing boutique offering full outfits to women in their midlife. Her mission is to "Teach Women to Wear their Worthiness."



- **EVOLUTION OF BEAUTY:** Amanda Pudil opened for business in August. Amanda has been an esthetician for 15 yrs. Her goal with all her clients is to help them improve self-care and education as well as consistency. Most of all she enjoys watching the evolution into beauty. Offering a wide variety of facials, waxing, and make-up application.



- **NESSA'S NATURALS:** Vanessa Torke of rural Hanley Falls took her passion of "green beauty" to the next level by opening this shop. Nessa's Naturals is a green beauty boutique that focuses on self-care and pampering. Renovations were made to restore the beautiful original tin ceiling tiles, bringing back original charm to downtown Marshall.



- **NETTIE'S:** Nettie's is a shop that offers handcrafted items, new merchandise such as candles, florals, napkins, and other fun and unique décor, and reimagined vintage items. Jennifer Griebel wanted to open shop for the past 5 years and opened up this year.



- **MAIN-STAY CAFE & COFFEE CO:** (Formerly The Daily Grind) New ownership in April 2018 brought a facelift to the interior giving it a more updated, modern and cozy feel. Main-Stay is open daily serving delicious home-made food. They employ two full-time staff and 4-6 part-time staff. Main-Stay strives to be what its name means: "a very important part of something; provides support and makes it possible for something to exist or succeed."

☐ SHAY PHOTOGRAPHY

- **SHAY PHOTOGRAPHY:** Shay Photography has been in operation for a few years, but she opened the doors to her physical location in May 2018, after extensive renovations were completed. Her studio was a vacant raw space located on 3rd Street above Nessa's Naturals. Original hardwood floors were refinished, creating a charming studio space with open air 14ft ceilings.

BUILDING PERMIT ACTIVITY

of Residential Permits



380
RESIDENTIAL
PERMITS

Valuation of Residential Permits

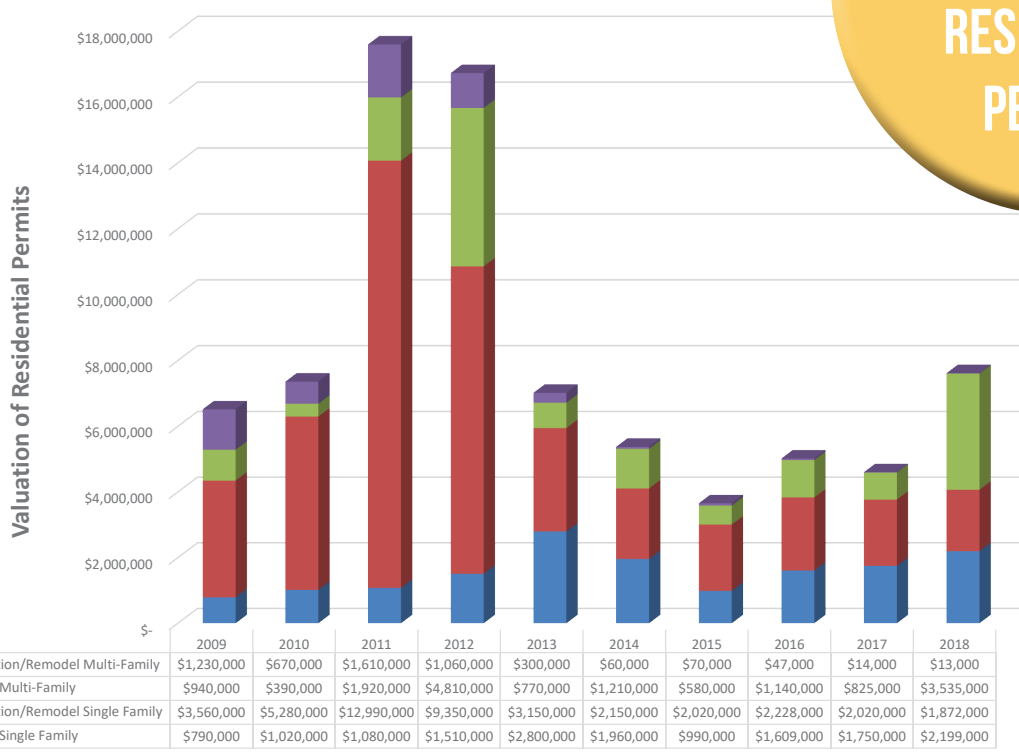

\$7.62M
RESIDENTIAL
PERMITS

91

COMMERCIAL PERMITS

of Commercial Permits

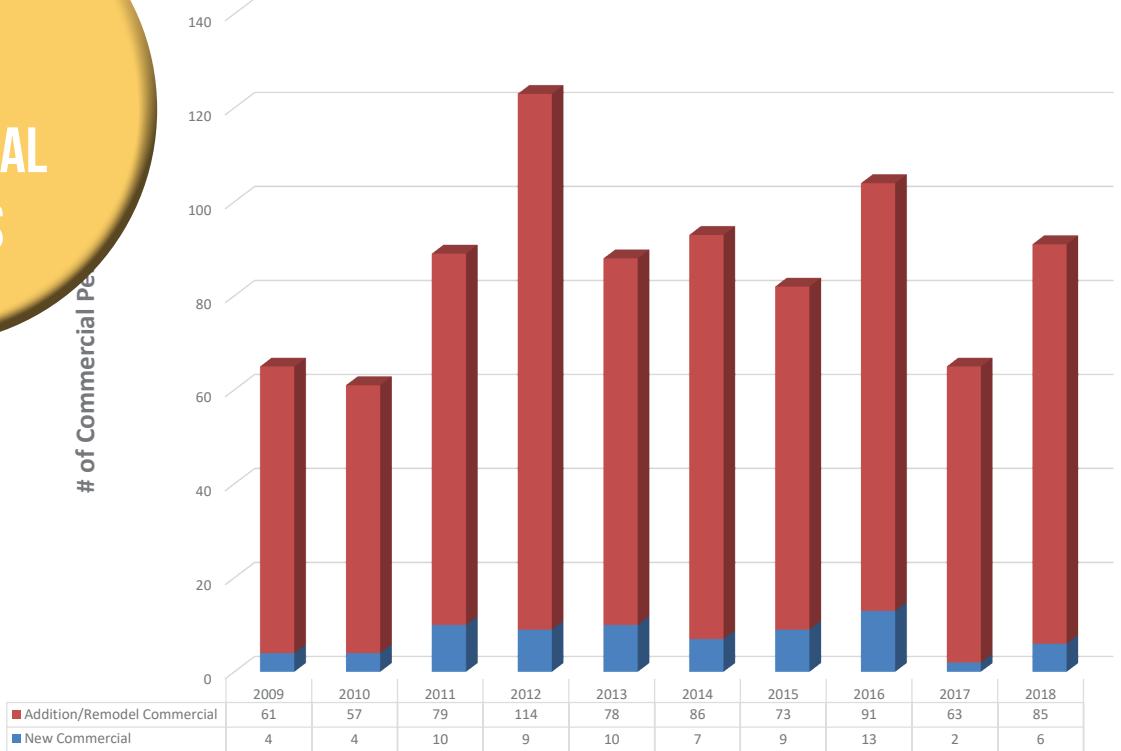

\$9.55M

COMMERCIAL PERMITS

Valuation of Commercial Permits

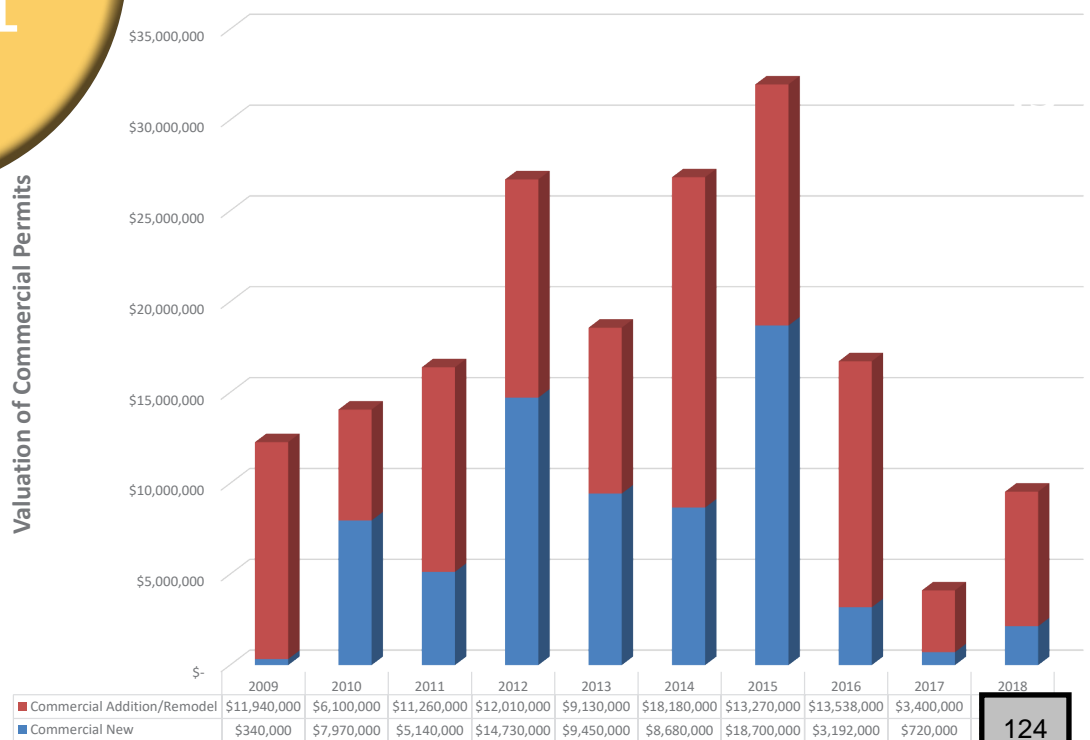

Total # of Signs



13
SIGN PERMITS

Total \$ of Signs

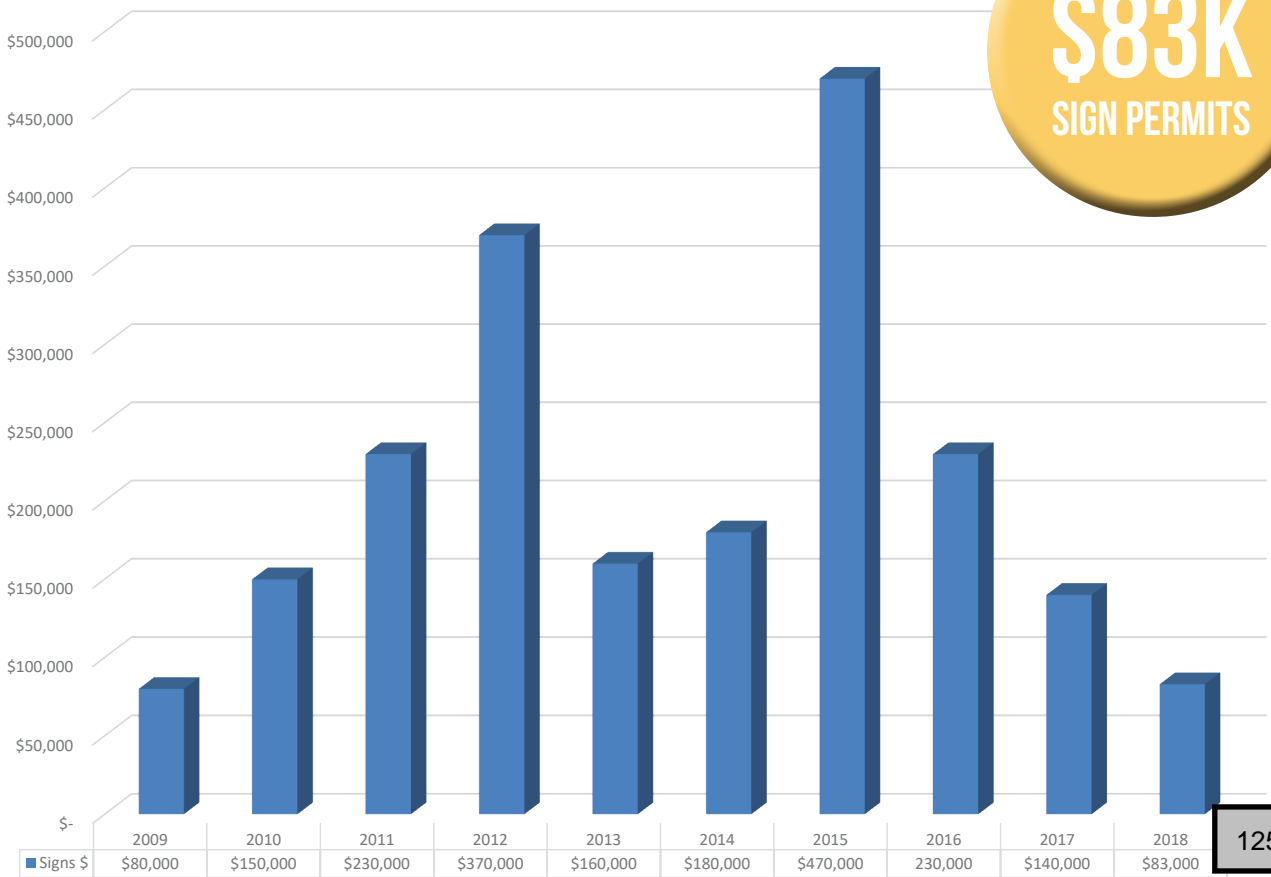

\$83K
SIGN PERMITS

125

BUILDING PERMIT ACTIVITY

Total # of Permits

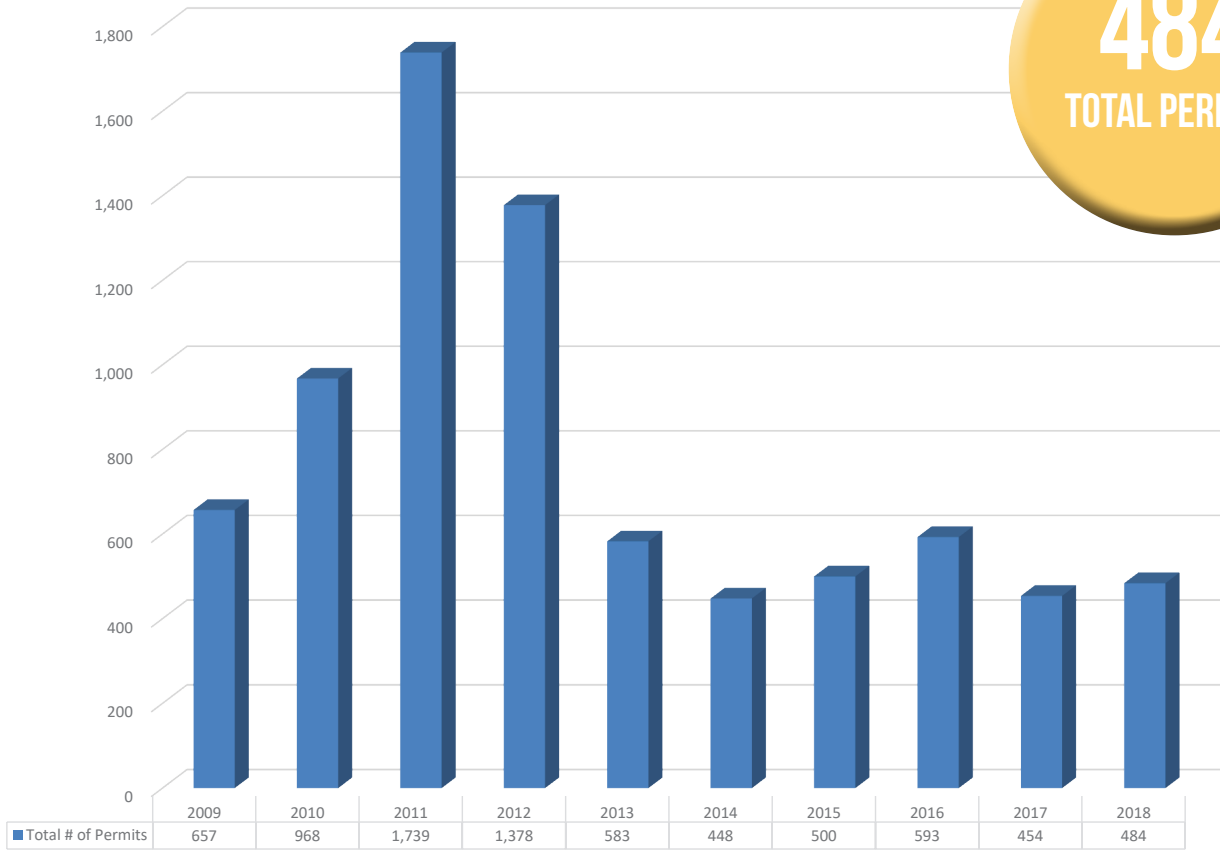

484
TOTAL PERMITS

Total Valuation of Permits

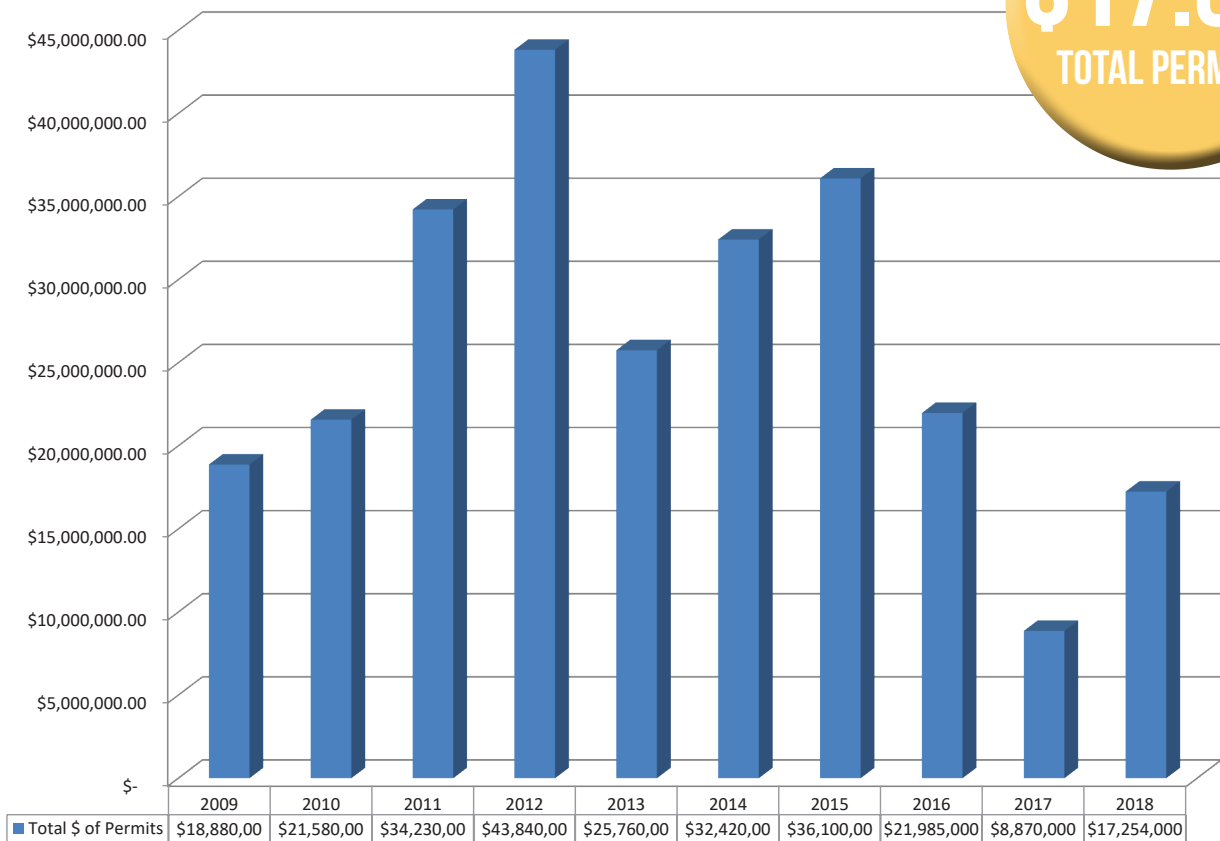

\$17.3M
TOTAL PERMITS

LOCAL SALES & USE TAX

\$2,003,096
2016 TOTAL TAX

\$1,812,078
2017 TOTAL TAX

\$2,033,370
2018 TOTAL TAX

Total of All Taxes Collected

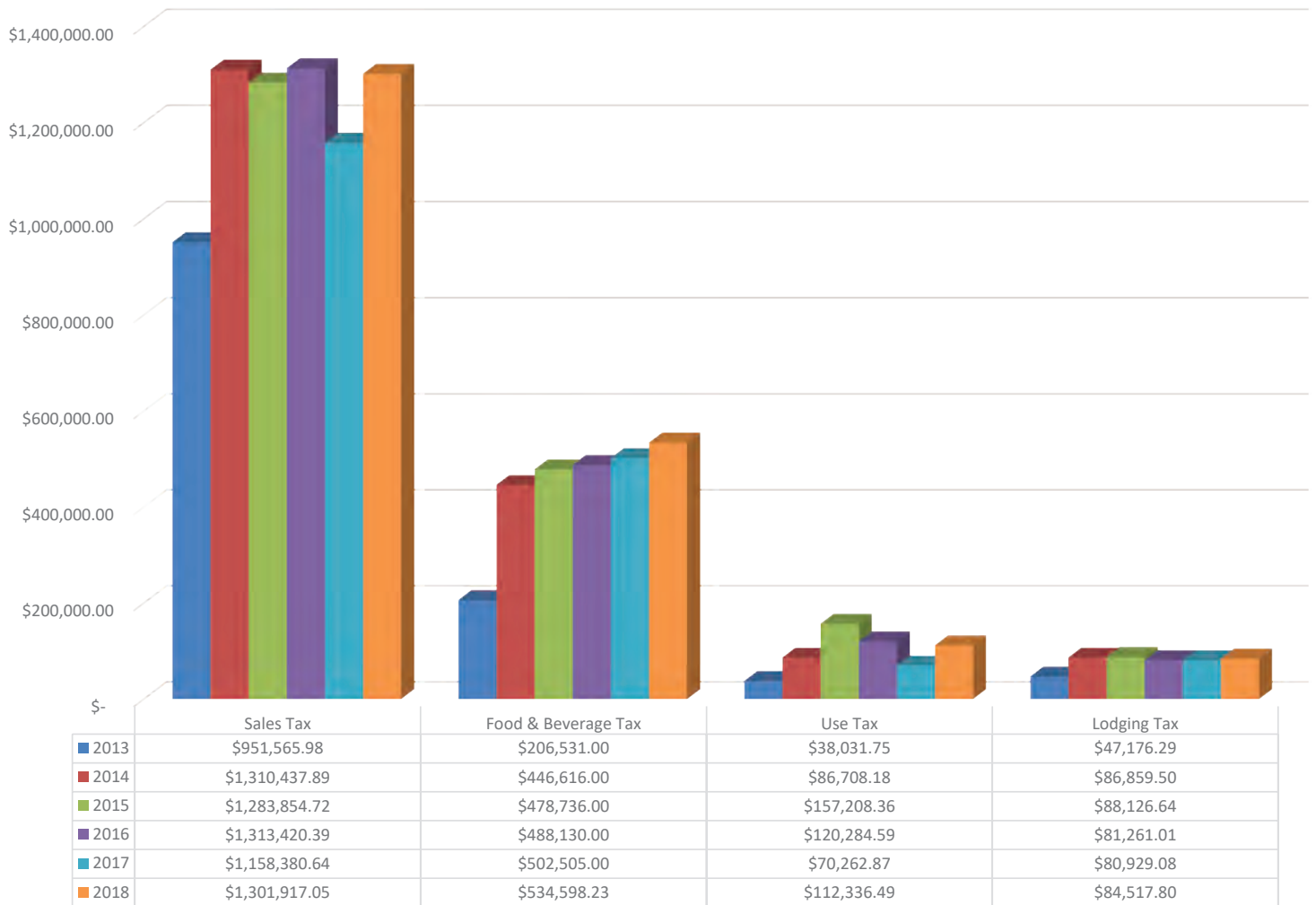



RETAIL TRADE ANALYSIS

According to the University of Minnesota Retail Trade Analysis report, the Minnesota Department of Revenue releases sales tax information each spring for the year that ended about 15 months earlier. The latest information indicates that Marshall's taxable retail and service sales increased 33% between 2009 and 2016, reaching an estimated total of \$196 million.

MERCHANDISE CATEGORY

Selected Categories	Taxable Sales 2013	Taxable Sales 2016	Dollar Change	Percent Change
Vehicles & Parts	\$11,301,083	\$13,034,843	+\$1,733,760	+15.34%
Furniture Stores	\$5,979,995	\$6,191,856	+\$211,861	+3.54%
Electronics	\$3,308,469	NA	NA	NA
Building Materials	\$64,988,798	\$58,594,742	-\$6,394,056	-9.84%
Food, Groceries	\$12,108,630	\$12,584,708	+\$476,078	+3.93%
Health, Personal Stores	\$348,941	\$176,711	-\$172,230	-49.36%
Gas/Convenience Stores	\$2,869,158	\$5,701,954	+\$2,832,796	+98.73%
Clothing	\$2,178,510	\$1,366,385	-\$812,125	-37.28%
Leisure Goods	\$3,605,050	\$3,101,113	-\$503,937	-13.98%
General Merchandise Stores	\$44,256,169	\$41,305,083	-\$2,951,086	-6.67%
Miscellaneous Retail	\$2,448,846	\$4,849,696	+\$2,400,850	+98.04%
Accommodations	\$5,580,302	\$4,976,273	-\$604,029	-10.82%
Eating & Drinking	\$30,273,254	\$32,185,543	+\$1,912,289	+6.32%
Total Retail and Services Sales	\$202,908,065	\$196,143,219	-\$6,764,846	-3.33%

* Figures not adjusted for inflation.

Marshall continues to be a destination for retail purchases in 2016. Without inflation adjustments, taxable sales in Marshall increased 33 percent from 2009 to 2016, while the number of firms rose 0.6 percent. Statewide, taxable sales increased 11.3 percent over the same time period and the number of firms fell 9.0 percent.

Merchandise Group	Variance Between Actual & Expected				Trade Area Pop. Gain or Loss	Number of Firms	Percent of Total Sales
	Expected Sales (\$millions)	Actual Sales (\$millions)	In Dollars (millions)	As % of Expected			
Vehicles & Parts	\$10.37	\$13.03	+\$2.66	+25.7%	3,543	11	6.6%
Furniture Stores	\$5.37	\$6.19	+\$0.82	+15.2%	2,100	9	3.2%
Electronics	\$5.79	NA	NA	NA	NA	NA	NA
Building Materials	\$19.85	\$58.59	+\$38.74	+195.2%	26,930	10	29.9%
Food, Groceries	\$13.77	\$12.58	-\$1.18	-8.6%	-1,184	7	6.4%
Health, Personal Stores	\$2.50	\$0.18	-\$2.32	-92.9%	-12,824	8	0.1%
Gas/Convenience Stores	\$4.49	\$5.70	+\$1.22	+27.1%	3,741	9	2.9%
Clothing	\$3.48	\$1.37	-\$2.12	-60.8%	-8,384	14	0.7%
Leisure Goods	\$4.58	\$3.10	-\$1.48	-32.3%	-4,454	11	1.6%
General Merchandise Stores	\$19.96	\$41.31	+\$21.35	+107.0%	14,763	5	21.1%
Miscellaneous Retail	\$5.70	\$4.85	-\$0.85	-14.9%	-2,053	26	2.5%
Amusement & Recreation	\$6.19	\$1.19	-\$5.01	-80.8%	-11,154	6	0.6%
Accommodations	\$8.05	\$4.98	-\$3.07	-38.2%	-5,269	8	2.5%
Eating & Drinking Places	\$32.25	\$32.19	-\$0.06	-0.2%	-26	43	16.4%
Repair, Maintenance	\$4.94	\$3.71	-\$1.23	-24.9%	-3,433	23	1.9%
Personal Services, Laundry	\$3.19	\$0.60	-\$2.59	-81.1%	-11,191	47	0.3%
Total Taxable Retail & Service*	\$181.27	\$196.14	+\$14.87	+8.2%	1,132	358	10

129

*All retail and service categories are included in Total Sales, including some categories not shown. Therefore, the merchandise groups shown here generally will not sum to Total Sales.

PULL FACTOR

According to the University of Minnesota Retail Trade Analysis report, there are several ways to measure performance other than dollars of sales. Economists expect cities of larger populations to have more sales since their potential customer base is larger. A pull factor index higher than 1.0 indicates that businesses are pulling in customers from outside their community. A lower pull factor usually indicates residents are leaving the community to make purchases. The 1.56 pull factor indicates that the City of Marshall is generating 56% more than expected based on population.

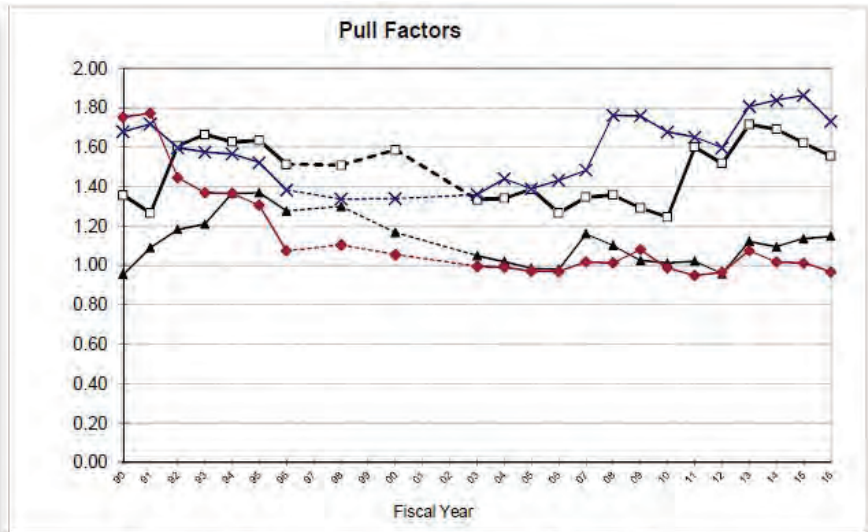

□ Marshall
▲ Redwood Falls
× Willmar
◆ Worthington

1.56
PULL FACTOR

Pull Factor

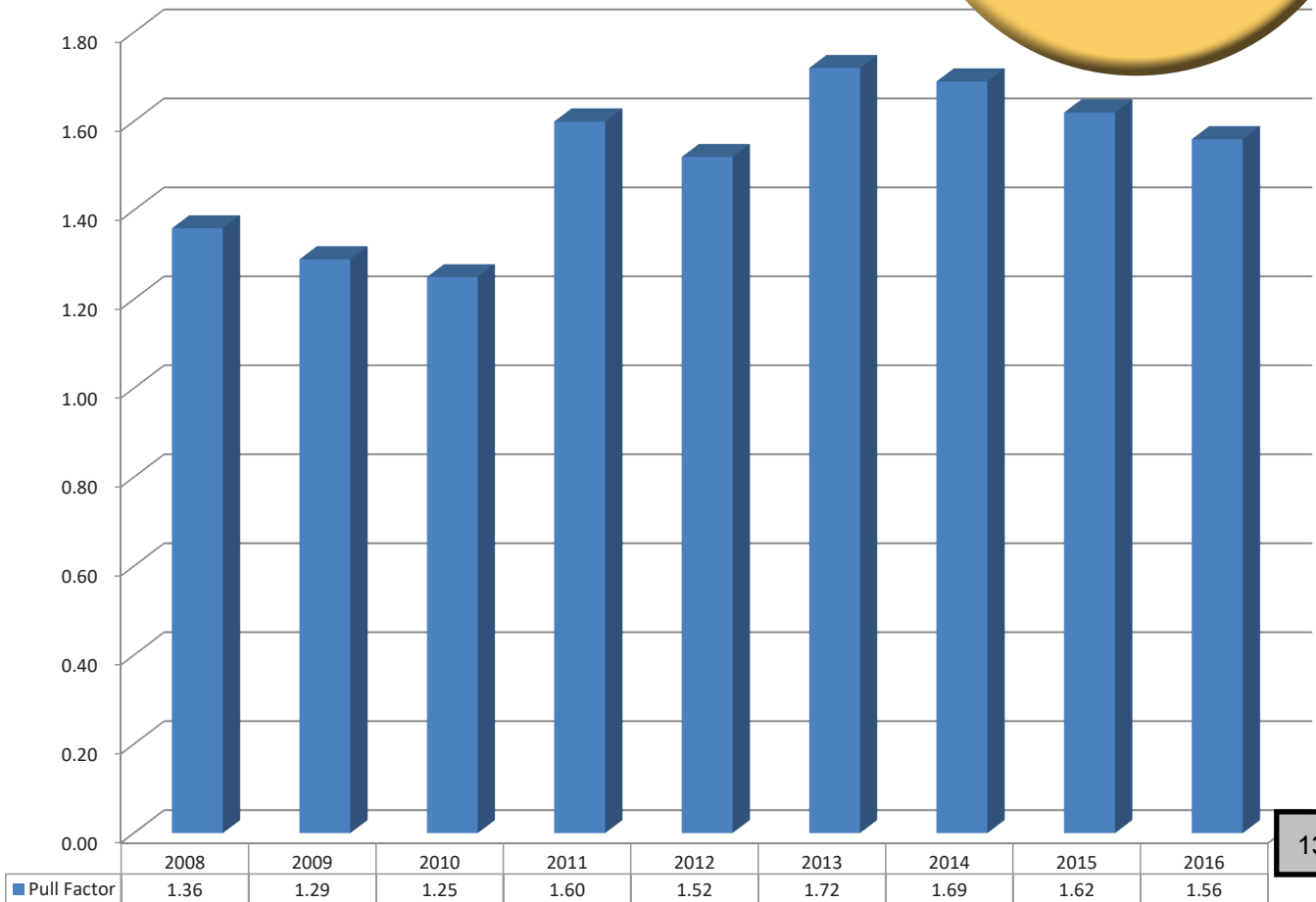

130



DEMOGRAPHIC ANALYSIS

Population and household data allow you to quantify the current market size and extrapolate future growth. Household income data is a good indicator of residents' spending power. Household income positively correlates with retail expenditures in many product categories. Age is an important factor to consider because personal expenditures change as individuals grow older.

Marshall's population continues to slowly increase. Marshall's median age is 31.6 years old. From 2010-2016, the age category with the largest estimated increase was Under 18 (199), and the age category with the largest estimated decrease was 18-34 (-450). Marshall's median household income comes in at \$44,561.

Data accuracy related to the graphs in this section is indicated as follows: **BLACK** indicates a coefficient of variation > 40%; **ORANGE** (preceded with one dot) indicates between 12 and 40%; and **RED BOLD** (preceded with two dots) indicates a coefficient of variation > 40%. This applies to all the graphs in this section, including Workforce Analysis, Educational Analysis, and Housing Analysis.

POPULATION TRENDS

Population

	Marshall city, MN	Lyon County, MN	U.S.
Population (2016*)	13,616	25,670	318,558,162
Population (2010*)	13,428	25,606	303,965,272
Population Change (2010*-2016*)	188	64	14,592,890
Population Pct. Change (2010*-2016*)	1.4%	0.2%	4.8%

Race

	Marshall city, MN	Lyon County, MN	U.S.
Total Population, 2016*	13,616	25,670	318,558,162
White alone	11,500	22,857	233,657,078
Black or African American alone	709	763	40,241,818
American Indian alone	118	139	2,597,817
Asian alone	567	902	16,614,625
Native Hawaii & Other Pacific Is. alone	0	0	560,021
Some other race alone	578	770	15,133,856
Two or more races	144	239	9,752,947

Percent of Total

White alone	84.5%	89.0%	73.3%
Black or African American alone	5.2%	3.0%	12.6%
American Indian alone	0.9%	0.5%	0.8%
Asian alone	4.2%	3.5%	5.2%
Native Hawaii & Other Pacific Is. alone	0.0%	0.0%	0.2%
Some other race alone	4.2%	3.0%	4.8%
Two or more races	1.1%	0.9%	3.1%

AGE/GENDER DISTRIBUTION

31.6
MEDIAN AGE

2016* Breakout

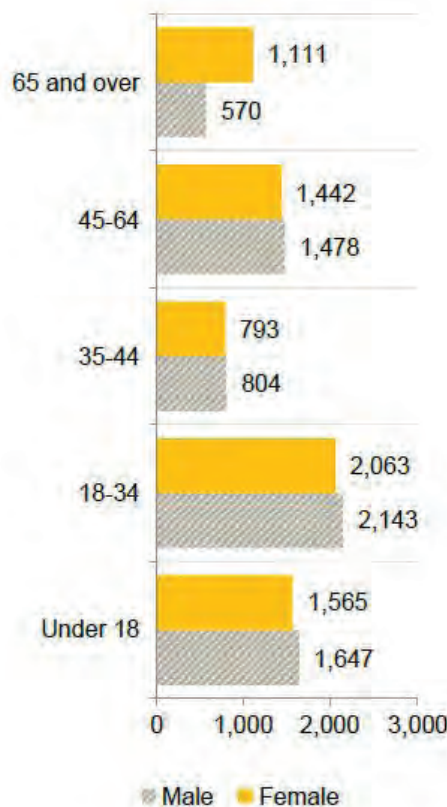

Change 2010*-2016*

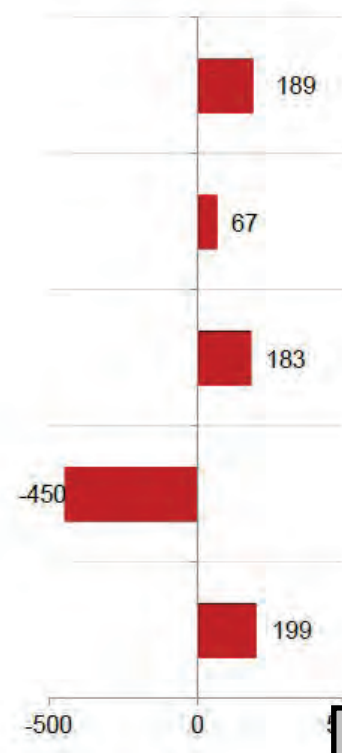

132

HOUSEHOLD INCOME

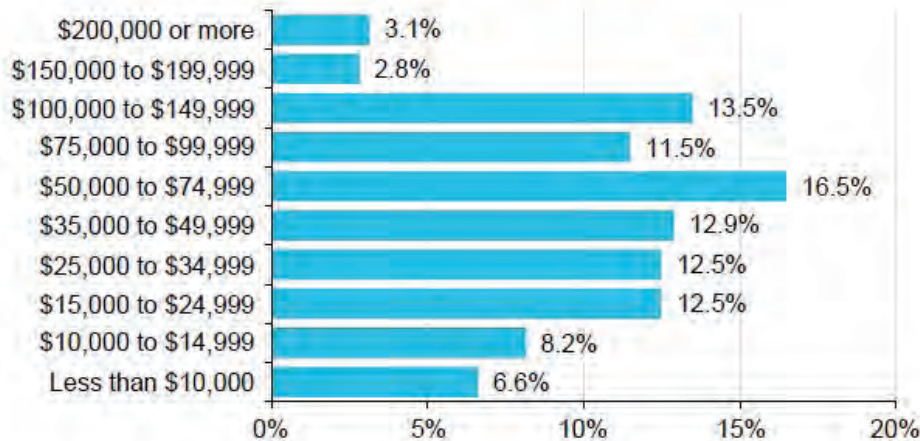

\$44,561
MARSHALL MEDIAN
HOUSEHOLD INCOME

POVERTY LEVEL

Poverty Prevalence

	Marshall city, MN	Lyon County, MN	U.S.
People, 2016*	12,685	24,497	310,629,645
Families, 2016*	3,074	6,420	77,608,829
People Below Poverty	2,414	3,396	46,932,225
Families below poverty	410	604	8,543,087

Percent of Total

People Below Poverty	19.0%	13.9%	15.1%
Families below poverty	13.3%	9.4%	11.0%

Poverty Rate by Age & Family Type~

	Marshall city, MN	Lyon County, MN	U.S.
People, 2016*	19.0%	13.9%	15.1%
Under 18 years	25.1%	18.8%	21.2%
65 years and older	11.1%	8.5%	9.3%
Families, 2016*	13.3%	9.4%	11.0%
Families with related children < 18 years	22.2%	16.3%	17.4%
Married couple families	4.2%	3.5%	5.5%
with children < 18 years	7.6%	6.1%	7.9%
Female householder, no husband present	48.1%	40.8%	29.9%
with children < 18 years	60.0%	49.4%	39.7%

~Poverty rate by age and family type is calculated by dividing the number of people by demographic in poverty by the total population of that demographic.

Individuals & Families Below Poverty, 2016*

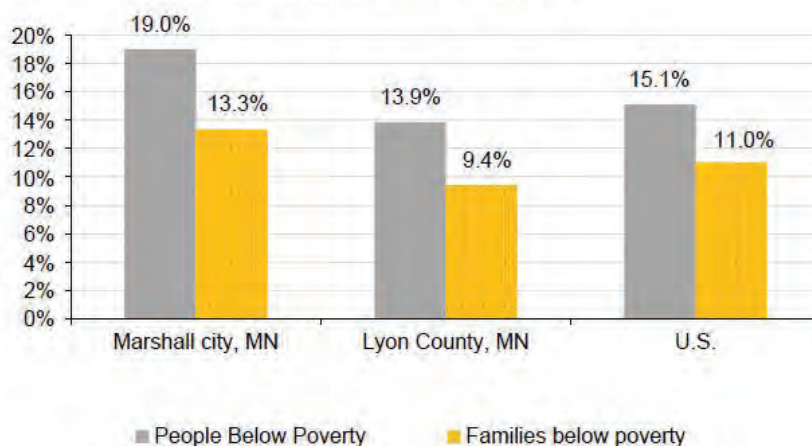

410
FAMILIES BELOW
POVERTY LEVEL



WORKFORCE ANALYSIS

The Schwan Food Company, one of Minnesota's largest private companies; US Bancorp Business Equipment Finance Group, a business equipment leasing company; Avera Marshall Regional Medical Center, a 49-bed regional hospital, a medical clinic and surgery center; Southwest Minnesota State University, the top-ranked public liberal arts college in the Midwest, along with many other public and private companies --- large and small --- call Marshall home. Marshall has consistently been below the state and county unemployment rate over the past ten years.

UNEMPLOYMENT RATE

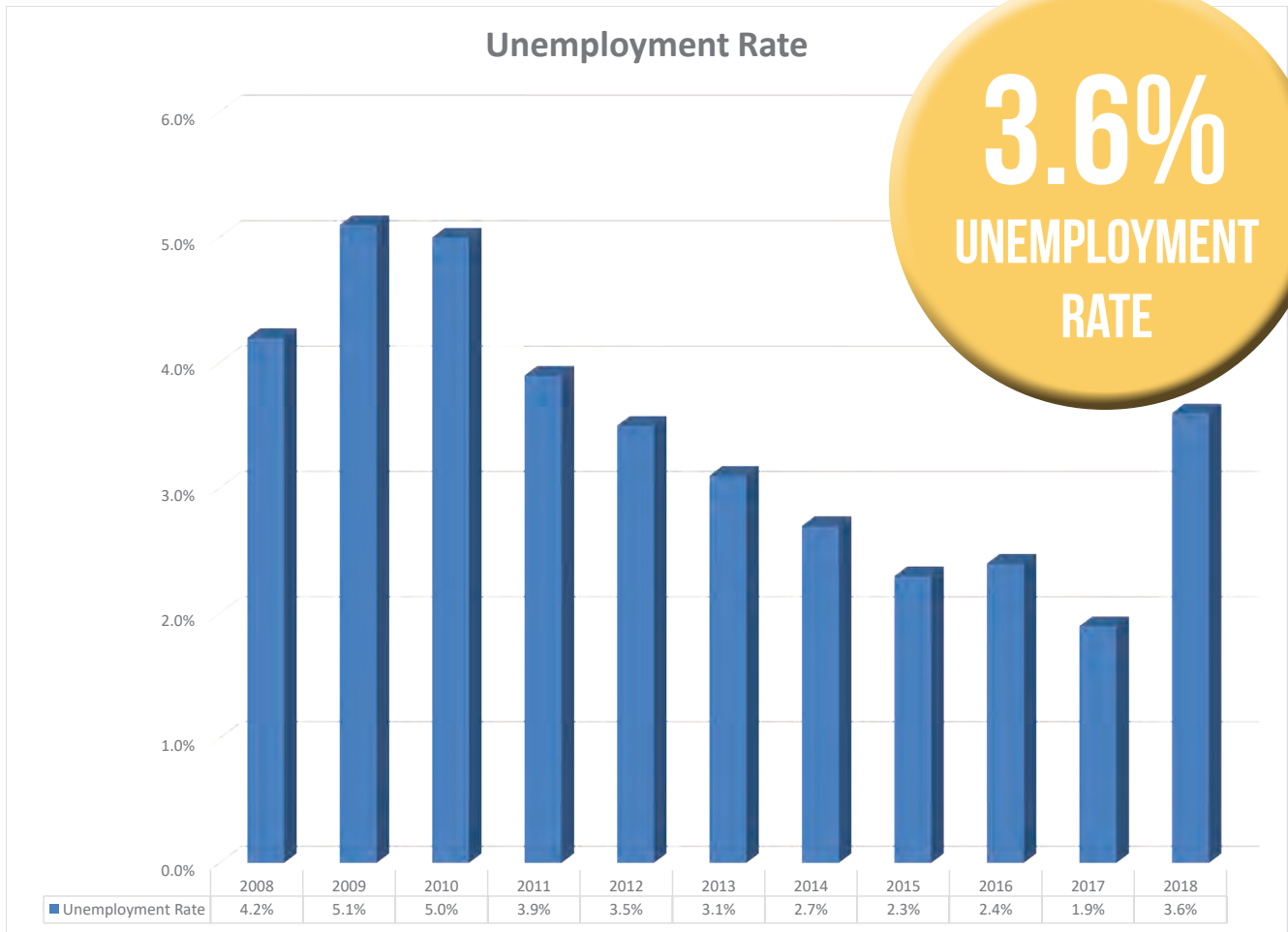

3.6%
UNEMPLOYMENT RATE

INDUSTRY EMPLOYMENT

	Marshall city, MN	Lyon County, MN	U.S.
Civilian employees > 16 years, 2016*	7,457	13,862	148,001,326
Ag, forestry, fishing & hunting, mining	260	1,029	2,843,703
Construction	401	831	9,256,637
Manufacturing	1,323	2,179	15,316,355
Wholesale trade	300	540	3,993,420
Retail trade	976	1,672	17,027,853
Transport, warehousing, and utilities	262	571	7,411,283
Information	40	124	3,131,838
Finance and ins, and real estate	748	1,246	9,731,609
Prof, mgmt, admin, & waste mgmt	377	659	16,516,075
Edu, health care, & social assistance	1,606	3,070	34,202,980
Arts, entertain, rec, accomod, & food	748	1,061	14,316,298
Other services, except public admin	142	420	7,275,839
Public administration	274	460	6,977,436

Percent of Total

Ag, forestry, fishing & hunting, mining	3.5%	7.4%	1.9%
Construction	5.4%	6.0%	6.3%
Manufacturing	17.7%	15.7%	10.3%
Wholesale trade	4.0%	3.9%	2.7%
Retail trade	13.1%	12.1%	11.5%
Transport, warehousing, and utilities	3.5%	4.1%	5.0%
Information	0.5%	0.9%	2.1%
Finance and ins, and real estate	10.0%	9.0%	6.6%
Prof, mgmt, admin, & waste mgmt	5.1%	4.8%	11.2%
Edu, health care, & social assistance	21.5%	22.1%	23.1%
Arts, entertain, rec, accomod, & food	10.0%	7.7%	9.5%
Other services, except public admin	1.9%	3.0%	4.9%
Public administration	3.7%	3.3%	4.7%

HOUSEHOLD EARNINGS

Household Earnings

	Marshall city, MN	Lyon County, MN	U.S.
Total households, 2016*	5,360	10,072	117,716,237
Labor earnings	4,372	8,247	91,496,981
Social Security (SS)	1,256	2,665	35,555,268
Retirement income	685	1,265	21,509,627
Supplemental Security Income (SSI)	149	315	6,355,071
Cash public assistance income	298	372	3,147,577
SNAP (previously Food Stamps)	619	956	15,360,951

Percent of Households Receiving Earnings, by Source, 2016*

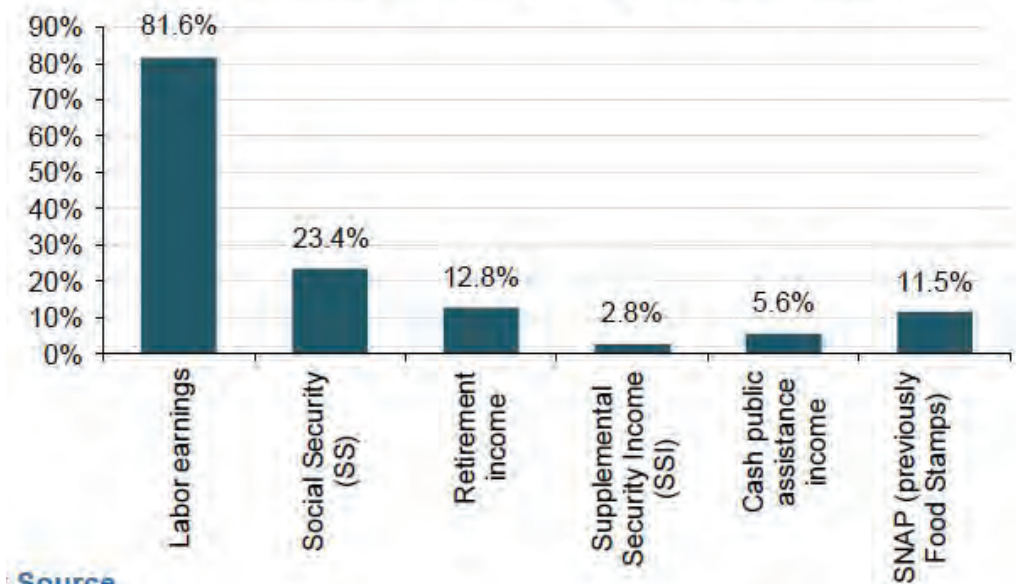

81.6%
LABOR EARNINGS

EMPLOYMENT OCCUPATION

	Marshall city, MN	Lyon County, MN	U.S.
Civilian employees > 16 years, 2016*	7,457	13,862	148,001,326
Management, professional, & related	2,404	4,806	54,751,318
Service	1,176	2,158	26,765,182
Sales and office	1,629	2,933	35,282,759
Farming, fishing, and forestry	192	329	1,057,193
Construction, extract, maint, & repair	357	679	7,404,356
Production, transportation	1,395	2,386	18,030,435

Percent of Total

Management, professional, & related	32.2%	34.7%	37.0%
Service	15.8%	15.6%	18.1%
Sales and office	21.8%	21.2%	23.8%
Farming, fishing, and forestry	2.6%	2.4%	0.7%
Construction, extract, maint, & repair	4.8%	4.9%	5.0%
Production, transportation	%	17.2%	

JOB VACANCIES (LYON COUNTY)

Table 30. Job Vacancy Survey Results, Qtr. 2 2018

Region 8	Number of Total Vacancies	Percent Part-time	Percent Temporary or Seasonal	Requiring Post-Secondary Education	Requiring 1 or More Years of Work Exp.	Requiring Certificate or License	Median Hourly Wage Offer	Job Vacancy Rate
Total, All Occupations	3,682	23%	19%	14%	46%	36%	\$12.83	6.8
Management	32	0%	0%	96%	100%	16%	\$35.00	1.4
Business & Financial Operations	24	4%	0%	72%	91%	38%	\$21.61	1.5
Computer & Mathematical	8	0%	0%	63%	82%	38%	\$28.41	2.3
Architecture & Engineering	27	0%	5%	82%	89%	9%	\$27.58	4.7
Life, Physical & Social Sciences	21	0%	0%	27%	44%	31%	\$18.70	6.2
Community & Social Service	12	22%	0%	82%	77%	72%	\$20.45	1.1
Legal	#N/A	#N/A	#N/A	#N/A	#N/A	#N/A	#N/A	#N/A
Education, Training & Library	111	40%	16%	93%	89%	95%	\$21.84	3.1
Arts, Design, Entertainment & Media	30	79%	24%	13%	27%	37%	\$11.44	9.5
Healthcare Practitioners & Technical	195	37%	0%	91%	60%	90%	\$27.05	6.2
Healthcare Support	91	57%	0%	1%	0%	87%	\$13.14	3.4
Protective Service	12	65%	8%	13%	2%	77%	\$11.04	1.6
Food Preparation & Serving Related	429	24%	2%	0%	32%	0%	\$10.38	9.1
Building, Grounds Cleaning & Maint.	265	29%	20%	1%	10%	5%	\$10.67	15.2
Personal Care & Service	71	50%	79%	23%	1%	83%	\$11.73	2.8
Sales & Related	422	20%	1%	6%	72%	0%	\$12.44	8.1
Office & Administrative Support	317	46%	28%	20%	24%	48%	\$10.00	4.4
Construction & Extraction	537	0%	16%	0%	91%	2%	\$11.97	22.3
Installation, Maintenance & Repair	147	1%	63%	14%	28%	70%	\$14.81	6.1
Production	159	9%	1%	11%	20%	9%	\$11.10	2.2
Transportation & Material Moving	663	25%	39%	2%	30%	84%	\$14.47	15.2
Internships	#N/A	#N/A	#N/A	#N/A	#N/A	#N/A	#N/A	#N/A

Source: DEED Job Vacancy Survey, Qtr. 2 2018

Figure 16. Job Vacancies by Industry, Qtr. 2 2018

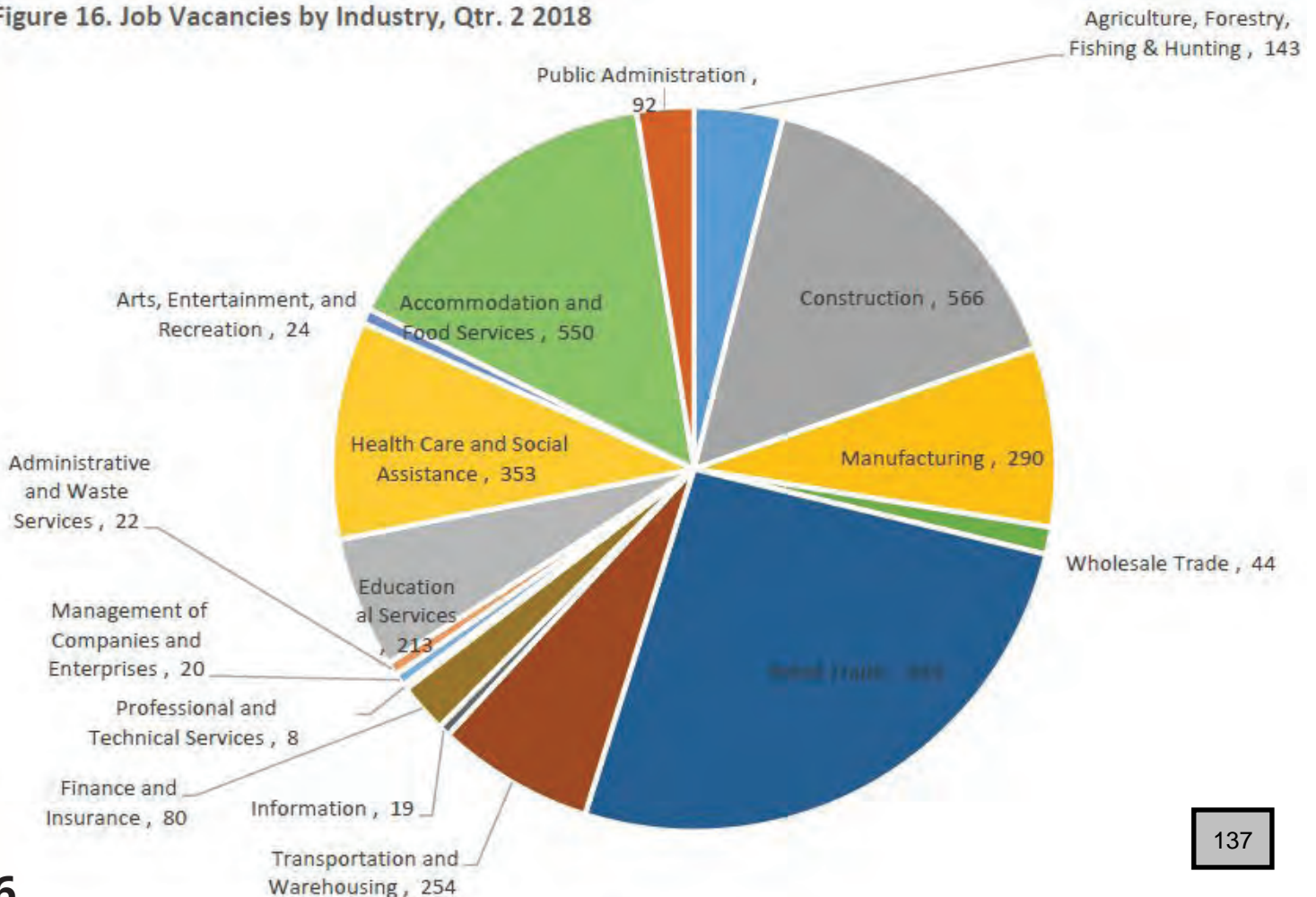

EMPLOYMENT PROJECTIONS

Table 31. Regional Employment Projections, 2016-2026

Occupational Group	Southwest						
	2016 Estimate	2026 Projection	2016-2026 Percent Change	Total Change	Labor Force Exit Openings	Transfer Openings	2016-2026 Total Hires
Total, All Occupations	211,618	213,503	0.9%	1,885	103,553	128,512	233,950
Management	24,465	24,215	-1.0%	-250	10,908	7,305	17,963
Business & Financial Operations	6,489	6,876	6.0%	387	1,989	3,844	6,220
Computer & Mathematical	2,177	2,186	0.4%	9	391	1,049	1,449
Architecture & Engineering	2,382	2,612	9.7%	230	646	1,172	2,048
Life, Physical, & Social Science	1,462	1,522	4.1%	60	383	910	1,353
Community & Social Service	4,113	4,324	5.1%	211	1,763	2,895	4,869
Legal	835	850	1.8%	15	205	271	491
Education, Training, & Library	12,206	12,406	1.6%	200	5,243	5,092	10,535
Arts, Design, Entertainment, & Media	3,039	2,886	-5.0%	-153	1,290	1,501	2,638
Healthcare Practitioners & Technical	10,007	10,414	4.1%	407	2,771	2,768	5,946
Healthcare Support	6,503	6,671	2.6%	168	3,848	3,531	7,547
Protective Service	2,932	2,889	-1.5%	-43	1,191	1,418	2,566
Food Preparation & Serving Related	15,692	15,278	-2.6%	-414	11,361	14,976	25,923
Building, Grounds Cleaning & Maint.	6,991	7,081	1.3%	90	4,287	4,481	8,858
Personal Care & Service	11,380	11,707	2.9%	327	8,833	7,548	16,708
Sales & Related	19,876	19,571	-1.5%	-305	12,249	15,354	27,298
Office & Administrative Support	25,579	24,376	-4.7%	-1,203	12,990	14,676	26,463
Farming, Fishing, & Forestry	3,824	4,625	20.9%	801	1,551	4,684	7,036
Construction & Extraction	9,760	10,374	6.3%	614	3,573	6,397	10,584
Installation, Maintenance, & Repair	7,796	8,343	7.0%	547	2,746	4,718	8,011
Production	19,287	18,761	-2.7%	-526	7,829	13,681	20,984
Transportation & Material Moving	19,188	20,669	7.7%	1,481	9,962	13,458	24,901

Source: DEED 2016-2026 Employment Outlook



MAJOR EMPLOYERS

- The Schwan Food Company - 1,100
- Avera Marshall - 800
- U.S. Bancorp Business Equipment Finance Group - 550
- Turkey Valley Farms - 450
- Southwest Minnesota State University - 440
- Marshall Public Schools - 420
- Hy-Vee Food Store - 400
- Wal-Mart - 225
- Archer Daniels Midland - 230
- Runnings - 195
- North Star Mutual Insurance Company - 195
- Vishay HiRel Systems LLC - 145
- REM Southwest Services - 150
- Menards - 135
- Cliff Viessman Inc. - 125
- City of Marshall - 110
- Ralco Nutrition - 110
- United Community Action Partnership - 90
- Reinhart Food Service - 90
- BH Electronics - 75



17
100+ EMPLOYEES

Marshall is strongly positioned and well-diversified across many business sectors including healthcare, education, manufacturing, retail, agriculture, and service related industries. This makes Marshall a strong, well-rounded, and resilient community with a balanced local economy. With easy access to quality healthcare, utilities, transportation and amenities, Marshall is a great place to start or grow your business. SW Minnesota one of the fastest growing regions in rural Minnesota and Marshall is the hub of it all.

COMMUTING PATTERNS

Marshall is a labor importer – drawing workers from surrounding cities and counties. In addition, Marshall is home to four major highways intersecting: Highway 59, Highway 23, Highway 19, Highway 68. The population of 13,664 residents grows daily to 25,000 people as a result of a multitude of opportunities for employment, education, and retail shopping in the City of Marshall.

7,387
MARSHALL
WORKERS

88.6%
LESS THAN 24
MINUTES

57.7%
LESS THAN 10
MINUTES

	Marshall city, MN	Lyon County, MN	U.S.
Workers 16 years and over, 2016*	7,387	13,701	145,861,221
PLACE OF WORK:			
Worked in county of residence	6,972	12,568	105,598,812
Worked outside county of residence	415	1,133	40,262,409
TRAVEL TIME TO WORK:			
Less than 10 minutes	4,264	5,797	17,927,517
10 to 14 minutes	1,499	2,322	19,223,448
15 to 19 minutes	518	1,435	21,399,796
20 to 24 minutes	265	1,386	20,377,556
25 to 29 minutes	35	482	8,749,447
30 to 34 minutes	175	683	19,027,315
35 to 39 minutes	24	84	4,014,655
40 to 44 minutes	25	55	5,315,984
45 to 59 minutes	156	248	11,080,144
60 or more minutes	157	356	12,083,467
Mean travel time to work (minutes)	11.6	13.8	25.0
Percent of Total			
PLACE OF WORK:			
Worked in county of residence	94.4%	91.7%	72.4%
Worked outside county of residence	5.6%	8.3%	27.6%
TRAVEL TIME TO WORK:			
Less than 10 minutes	57.7%	42.3%	12.3%
10 to 14 minutes	20.3%	16.9%	13.2%
15 to 19 minutes	7.0%	10.5%	14.7%
20 to 24 minutes	3.6%	10.1%	14.0%
25 to 29 minutes	0.5%	3.5%	6.0%
30 to 34 minutes	2.4%	5.0%	13.0%
35 to 39 minutes	0.3%	0.6%	2.8%
40 to 44 minutes	0.3%	0.4%	3.6%
45 to 59 minutes	2.1%	1.8%	7.6%
60 or more minutes	2.1%	2.6%	8.3%

Competing makes us strong, working together makes us stronger.



EDUCATIONAL ANALYSIS

Marshall is well known for its high quality education. Marshall is home to Marshall Public Schools, 3 Parochial Schools (True Light Christian School, Holy Redeemer School and Samuel Lutheran S and Southwest Minnesota State University. Marshall is well known for its high quality education. All students are provided countless opportunities and services to develop them into successful men and women in our community.

EDUCATIONAL ATTAINMENT

Educational attainment can be used as a measure of the quality of the resident labor force, and Minnesota is well known for the quality of education. Unlike the other counties in Southwest Minnesota, Lyon County has competitive educational attainment rates with the state of Minnesota, thanks to the presence of Southwest Minnesota State University in Marshall. Estimated 92.3% of the adult population had at least a high school diploma or GED, while estimated 31.3% had a bachelor's degree or higher.

2,470

**MARSHALL PUBLIC
SCHOOL ENROLLMENT**

83.5%

**HIGH SCHOOL
GRADUATION RATE**

6,910

**SMSU
ENROLLMENT**

SCHOOL ENROLLMENT

	Marshall city, MN	Lyon County, MN	U.S.
Total Population over 3 years old, 2016*	13,084	24,620	306,924,139
Enrolled in school:	4,396	7,152	82,148,370
Enrolled in nursery school, preschool	340	597	4,959,823
Enrolled in kindergarten	168	329	4,181,764
Enrolled in grade 1 to grade 4	689	1,366	16,342,506
Enrolled in grade 5 to grade 8	723	1,431	16,489,244
Enrolled in grade 9 to grade 12	582	1,212	16,985,786
Enrolled in college	1,894	2,217	23,189,247
Not enrolled in school	8,688	17,468	224,775,769

Percent of Total

Enrolled in school:	33.6%	29.0%	26.8%
Enrolled in nursery school, preschool	2.6%	2.4%	1.6%
Enrolled in kindergarten	1.3%	1.3%	1.4%
Enrolled in grade 1 to grade 4	5.3%	5.5%	5.3%
Enrolled in grade 5 to grade 8	5.5%	5.8%	5.4%
Enrolled in grade 9 to grade 12	4.4%	4.9%	5.5%
Enrolled in college	14.5%	9.0%	7.6%
Not enrolled in school	66.4%	71.0%	73.2%

	Marshall city, MN	Lyon County, MN	U.S.
Total Population 25 yrs or older, 2016*	8,198	16,448	213,649,147
No high school degree	635	1,251	27,818,380
High school graduate	7,563	15,197	185,830,767
Associates degree	902	1,923	17,469,724
Bachelor's degree or higher	2,565	4,404	64,767,787
Graduate or professional	763	1,207	24,577,867

Percent of Total

No high school degree	7.7%	7.6%	13.0%
High school graduate	92.3%	92.4%	86.9%
Associates degree	11.0%	11.7%	14.2%
Bachelor's degree or higher	31.3%	26.8%	30.5%
Graduate or professional	9.3%	7.3%	11.5%

MARSHALL PUBLIC SCHOOLS

Our growing student enrollment is one of the biggest factors in completing our budget each year. At the end of the 2017-2018 year, we received funding for 2,470 students in kindergarten through 12th grade. At the start of January for the 2018-2019 year, there were 2,470 students enrolled in those same grades, which is even with student enrollment last year. We have had an increase of 331 students in the last 7 years, that is a 15.5% increase. The enrollment growth has created space challenges for our district. A building bond referendum will be held in May 2019.

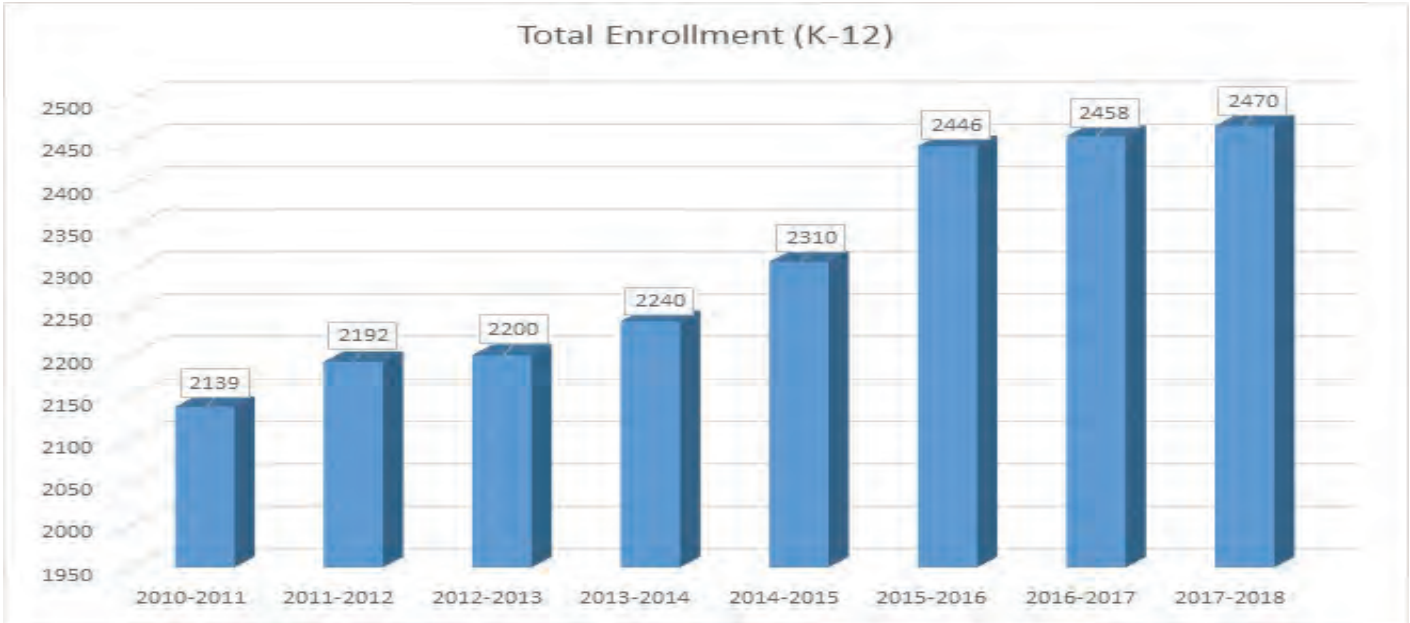

As shown in the graph above, student enrollment in kindergarten through grade twelve has grown significantly over the past seven years. Based on several factors, we anticipate that this enrollment growth will continue.

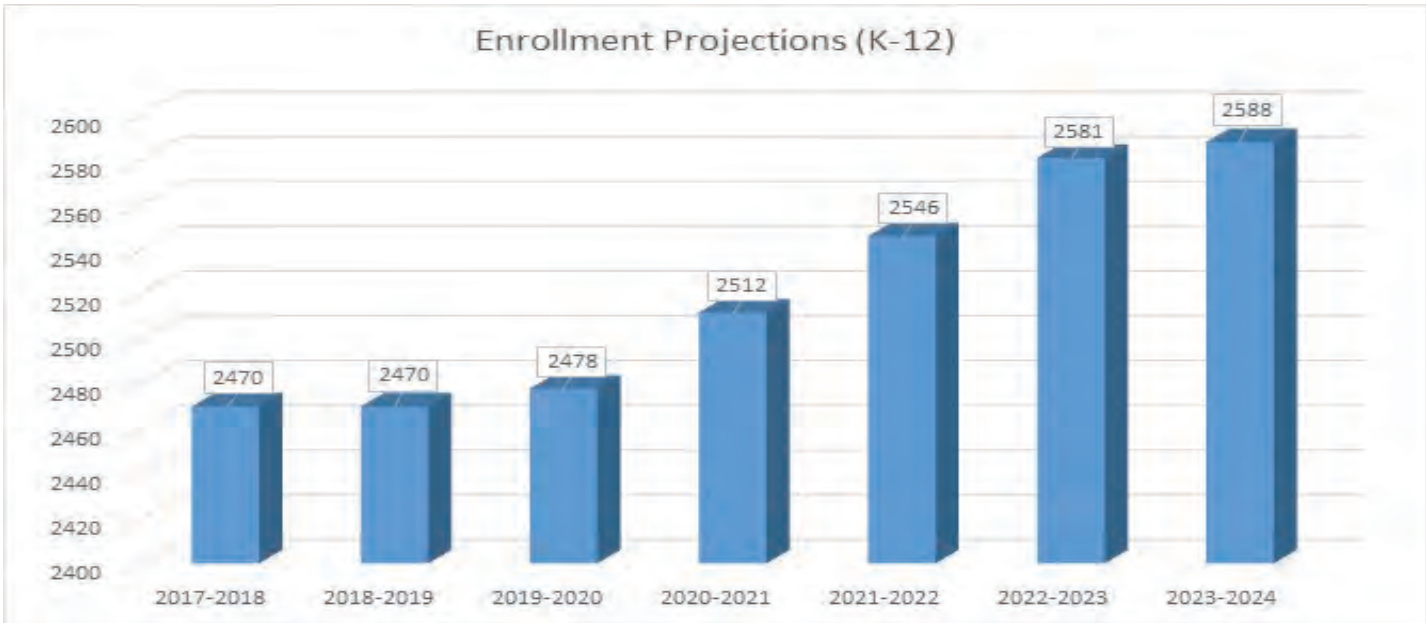

As shown in the graph above, student enrollment in kindergarten through 12th grade is projected to continue to increase from a low of 2,470 students in 2017-2018 to a forecasted enrollment high of 2,588 in 2023-2024. For the 2017-2018 school year we are at record enrollment numbers for the school district. In 2014, at the request of the school district, Hazel Reinhardt, a former Minnesota State Demographer, studied enrollment history and other factors to develop a comprehensive enrollment projection based on a variety of factors. Ms. Reinhardt's projections include births, kindergarten 'capture' rate, and incoming 9th grade increases due to tuitioned in and non-public schools/students. Her projections indicated an increase of anywhere between 18.6% and 23.3% from 2013-2014 and 2023-2024. Interestingly, Ms. Reinhardt's most aggressive projection for 17-18 was 2,446 students and our actual enrollment exceeded her most aggressive projection by 24 students. The increasing enrollment, along with the district's commitment to manageable student to teacher ratios, has created a need for additional classroom and learning space.

SOUTHWEST MN STATE UNIVERSITY

Southwest Minnesota State University serves approximately 6,910 students across the State of Minnesota and throughout the upper Midwest through a variety of undergraduate, graduate and concurrent enrollment programs. Approximately 2,122 undergraduate degree seeking students are served on-campus. SMSU is recognized for its affordability, quality and lifetime return on investment.

Enrollment Figures from Fall 2017

Total Headcount	6,910
Degree-seeking (undergrad)	2,122
Non-degree seeking	4,357
Graduate	431
Female	57.7%
Male	42.2%

Minnesota Residents	77.5%
Counties Represented	75
Out of State	22.5%
States Represented	38
International	6.1%
Countries Represented	27

SMSU Head Count

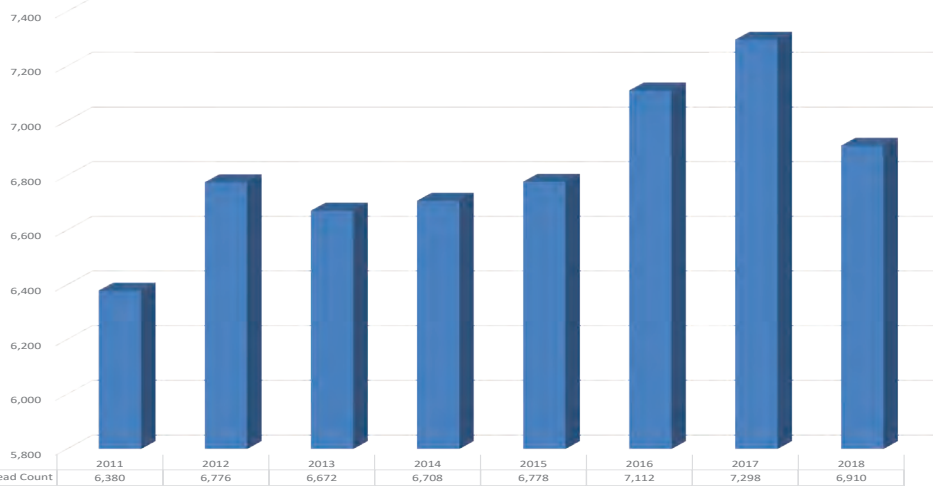

14%
CONTINUING THEIR
EDUCATION

97%
EMPLOYED IN FIELD
OF STUDY

99%
EMPLOYED SMSU
GRADUATES

Impact of Southwest Minnesota State University

Southwest Minnesota State University generates **\$173.1M** in economic impact per year



\$9.6M in state and local revenue

\$2.4M in community contributions

649 graduates annually

SOUTHWEST
MINNESOTA STATE UNIVERSITY

A member of the Minnesota State system

Supports and sustains **1,421** JOBS



HOUSING ANALYSIS

According to the Marshall Comprehensive Housing Needs Analysis report, the demographic characteristics of Marshall and the Primary Market Area show a growing demand for a variety of housing products, including: rental housing targeting the young adult (25 to 34) age group as well as the empty nester population (55 to 74 age group); entry-level ownership housing for first-time home buyers (25 to 39); move-up housing for the 35 to 44 age group; and, senior housing. In total, we find demand to supply 608 general occupancy housing units between 2015 and 2025. Demand is expected to favor rental housing, with 371 rental units and 237 for-sale housing units needed in Marshall by 2025.

HOUSING CHARACTERISTICS

Housing Characteristics

	Marshall city, MN	Lyon County, MN	U.S.
Total Housing Units, 2016*	5,804	11,179	134,054,899
Occupied	5,360	10,072	117,716,237
Vacant	444	1,107	16,338,662
For rent	219	369	2,855,844
Rented, not occupied	29	29	616,696
For sale only	129	185	1,395,797
Sold, not occupied	0	45	636,952
Seasonal, recreational, occasional	0	75	5,368,085
For migrant workers	0	0	35,398
Other vacant	67	404	5,429,890
Year Built			
Built 2010 or later	75	118	3,098,053
Built 2000 to 2009	755	1,214	19,705,347
Built 1990 to 1999	733	1,098	18,762,073
Built 1980 to 1989	940	1,311	18,355,676
Built 1970 to 1979	992	1,932	20,901,765
Built 1940 to 1969	1,747	3,155	35,773,834
Median year structure built [^]	1976	1970	1977

Percent of Total

Occupancy			
Occupied	92.4%	90.1%	87.8%
Vacant	7.6%	9.9%	12.2%
For rent	3.8%	3.3%	2.1%
Rented, not occupied	0.5%	0.3%	0.5%
For sale only	2.2%	1.7%	1.0%
Sold, not occupied	0.0%	0.4%	0.5%
Seasonal, recreational, occasional	0.0%	0.7%	4.0%
For migrant workers	0.0%	0.0%	0.0%
Other vacant	1.2%	3.6%	4.1%
Year Built			
Built 2010 or later	1.3%	1.1%	2.3%
Built 2000 to 2009	13.0%	10.9%	14.7%
Built 1990 to 1999	12.6%	9.8%	14.0%
Built 1980 to 1989	16.2%	11.7%	13.7%
Built 1970 to 1979	17.1%	17.3%	15.6%
Built 1940 to 1969	30.1%	28.2%	26.7%

■ Occupied ■ Vacant

92.4%

OCCUPIED

3.8%

FOR-RENT VACANT

2.2%

FOR-SALE VACANT

AFFORDABLE HOUSING

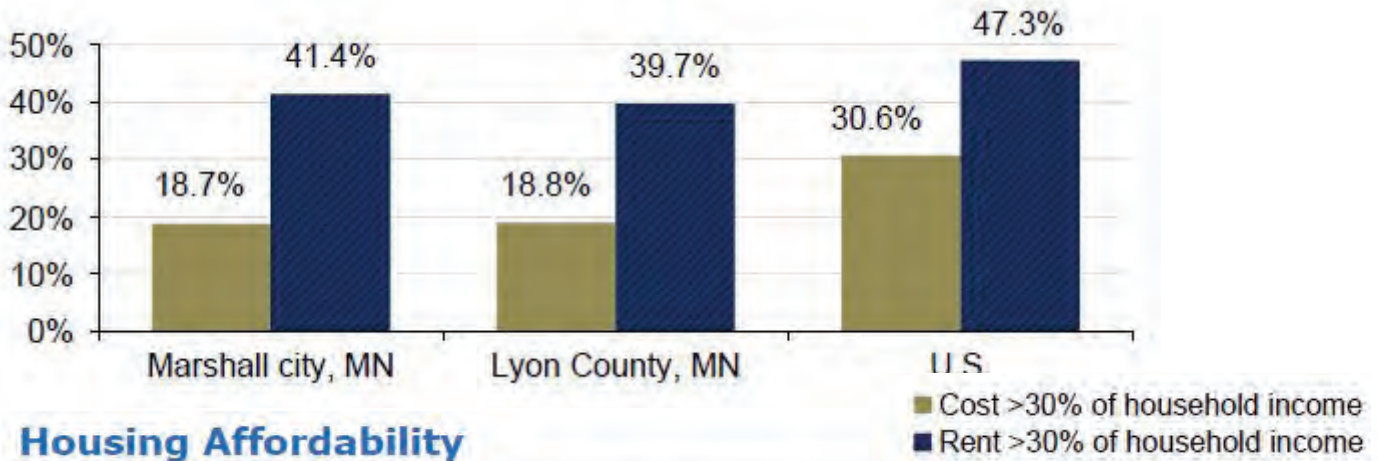

Housing Affordability

	Marshall city, MN	Lyon County, MN	U.S.
Owner-occupied mortgaged homes, 2016*	1,849	3,953	48,016,540
Cost >30% of household income	346	744	14,700,932
Specified renter-occupied units, 2016*	2,425	3,254	42,835,169
Rent >30% of household income	1,003	1,292	20,246,745
Median monthly mortgage cost [^] , 2016*	\$1,179	\$1,162	\$1,491
Median gross rent [^] , 2016*	\$615	\$614	\$949
Percent of Total			
Cost >30% of household income	18.7%	18.8%	30.6%
Rent >30% of household income	41.4%	39.7%	47.3%

[^] Median monthly mortgage cost and median gross rent are not available for metro/non-metro or regional aggregations.

1,849
OWNER OCCUPIED
HOUSING WITH MORTGAGE

\$1,179
MEDIAN MONTHLY
MORTGAGE

\$615
MEDIAN GROSS
RENT

WAGES & AFFORDABILITY

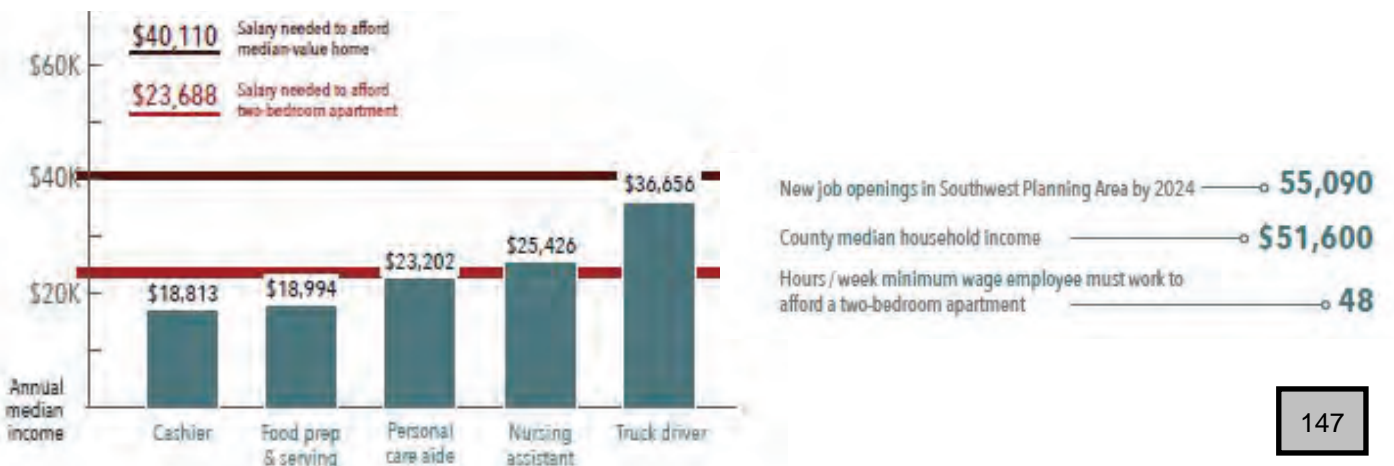



DEVELOPMENT OPPORTUNITY!

Prime Real Estate for Sale
Marshall EDA
507-337-0802

www.ci.marshall.mn.us
@CityofMarshallMN

www.discoversouthwestmn.com
@DiscoverSouthwestMN

Located in federally designated Opportunity Zone.
Inquire for details.

DEVELOPMENT OPPORTUNITIES

The City of Marshall has over 200+ acres of industrial park land available for development opportunities. In addition, the City of Marshall also has redevelopment projects available for interested parties.

COMMERCE PARK

Commerce Park spans across 136.03 developable acres and can be subdivided into as little as 5 acre lots. Commerce Park is located west of Highway 59 North and is centrally located in the industrial district of Marshall.

Commerce Park is currently zoned agriculture, but will transition to general industrial district.

The City of Marshall was awarded a \$2 Million Business Development Public Infrastructure Grant to build out Michigan Road. In addition, Commerce Park is located in the federally designated Opportunity Zone.

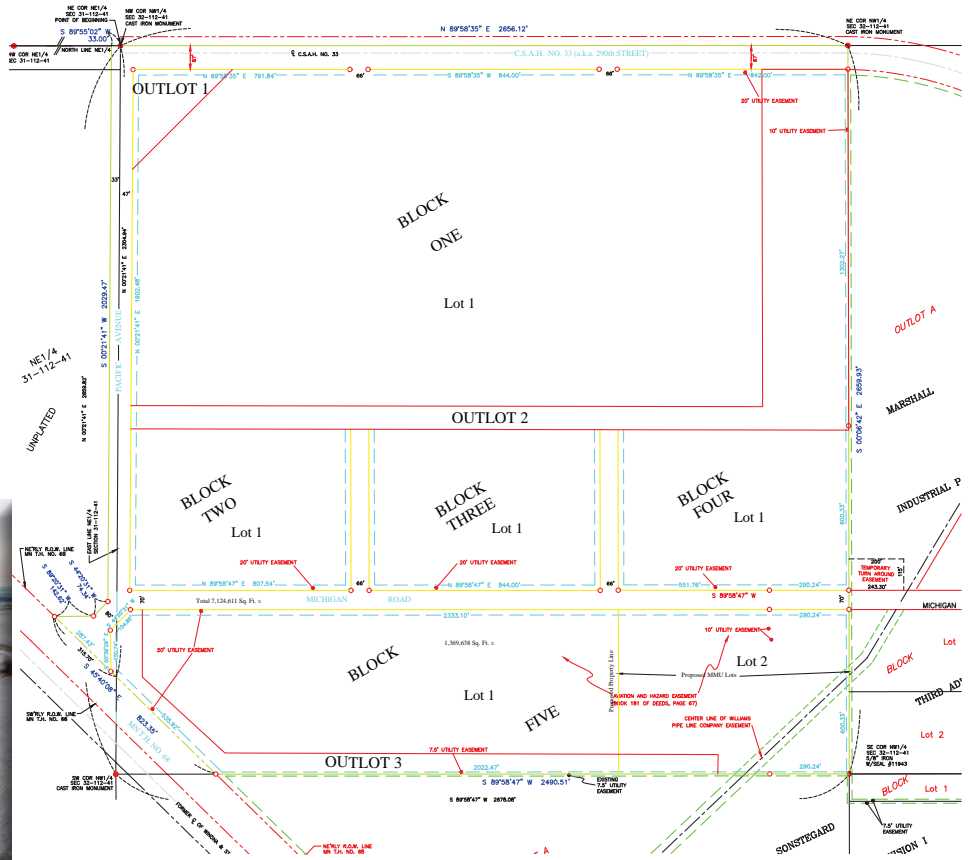

OPPORTUNITY ZONES

Opportunity Zones are a new community development program established by Congress in the Tax Cut and Jobs Act of 2017 to encourage long-term investments in low-income and urban communities nationwide. Opportunity Funds allow U.S. investors holding unrealized gains in stocks and mutual funds to pool their resources in projects located in Opportunity Zones, which will be invested in rebuilding low-income communities.

Minnesota Census Tract: 27083360500 was designated as an Opportunity Zone which includes Commerce Park and Victory Park (Amateur Sports Complex area).

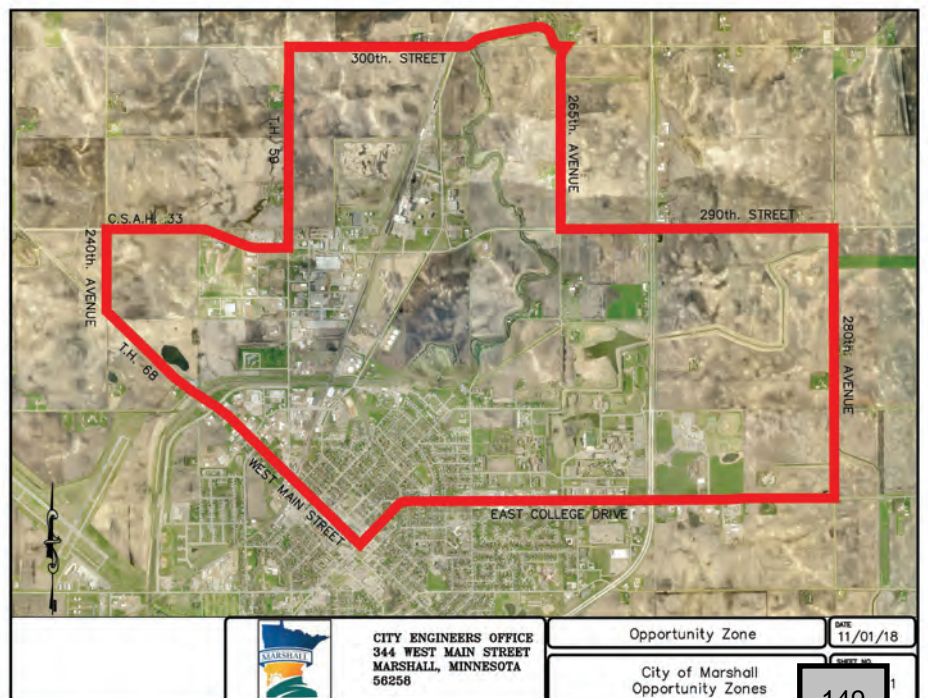

SONSTEGARD SUBDIVISION II

Sonstegard Subdivision II was initially 64.266 acres. The majority of the industrial park was filled within two years. Only one 1.2810 acre parcel is still available for development.

Sonstegard Subdivision II is located between Trunk Highway 68 and County Road 33 and is located at the heart of Marshall's industrial district. It is currently zoned general industrial.

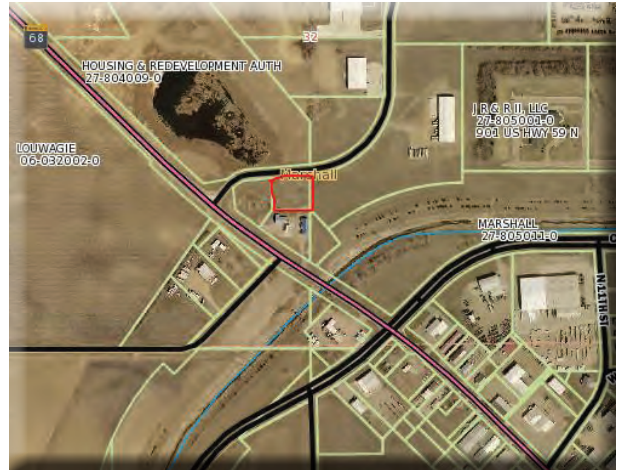

AIRPARK EAST

The Southwest Minnesota Regional Airport-Marshall/Ryan Field is a growing area and at present has over 25 developable acres. Located within easy access to air transportation, railroads, and the interstate, the airpark offers a prime location for businesses.

Located within easy access to air transportation, railroads, and highway systems, the airpark offers a prime location for businesses. We encourage developers and businesses to explore the development opportunities on the airpark and in the airport environs.

Southwest Minnesota Regional Airport-Marshall/Ryan Field's features include:

- 7,220-foot primary runway in length to handle corporate/commercial aircraft and possible future scheduled air service
- 4,000-foot crosswind runway
- BEACON, VOR/DME, ILS, weather computer
- Flight training and repair service
- Charter flights available to any point in North America and Canada



PARKWAY II

Parkway II Addition provides single-family housing opportunities of all kind. Parkway II is zoned single family residential and has a variety of building options for home buyers. Parkway II has 25 lots available from \$11,500-\$15,500/lot. Inquire about Tax Abatement Incentives as both the City of Marshall and Lyon County recently passed Tax Abatement Incentives for building new homes.

LOTS FOR SALE



PARKWAY II ADDITION

Edina Realty
 a Berkshire Hathaway affiliate

BILL ARCHBOLD
 Realtor
 507-829-5407
 BillArchbold@EdinaRealty.com

MOLLY ARCHBOLD
 Realtor
 507-530-6036
 MollyArchbold@EdinaRealty.com

thearchboldteam.edinarealty.com
 877-270-1289 • 1301 E. College Drive • Marshall, MN 56258

INQUIRE ABOUT TAX ABATEMENT INCENTIVES

PARKWAY III

Parkway III currently consists of 8.835 acres of city-owned land located on Legion Field Road/10th Street. Unique Opportunities purchased 9 acres of Parkway III for a 107-unit apartment development project that would invest around \$11 million. Amenities include stainless steel appliances, granite countertops, washers and dryers in each apartment. Hess Concrete also purchased .57 acres of Parkway III adjacent to their current property for potential future expansion projects.

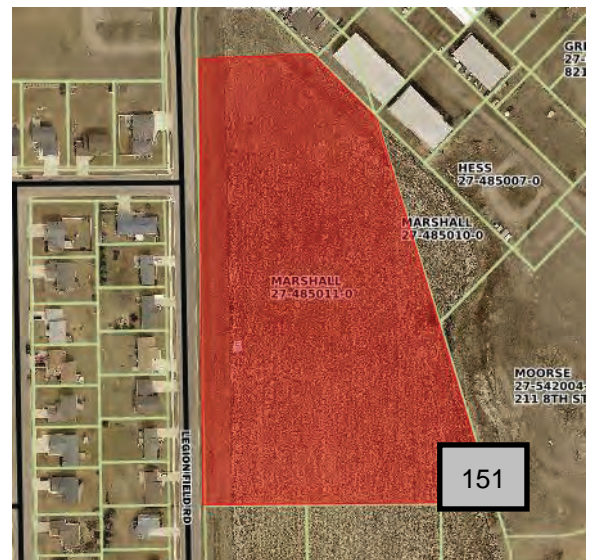

PARKWAY IV

Parkway IV consists of 31.10 acres located on London Road. Parkway IV is currently zoned general business and single-family residence. The City of Marshall has considered rezoning the property to light industrial. Parkway IV's recent infrastructure can be designated for high tech or bio businesses.



AMATEUR SPORTS COMPLEX

Building off of our newly constructed Red Baron Arena & Expo, which features two sheets of ice and an exposition center, the competition baseball/softball complex opened in Summer 2017. Victory Park has adjacent properties available for retail and restaurant development opportunities. Marshall is seeking hospitality, restaurant and retail enterprises that would complement each other and reach the amateur sports crowd along with the Southwest Minnesota State University population and our own community members. In addition, Victory Park is located in the federally designated Opportunity Zone.



Tiger Park Development

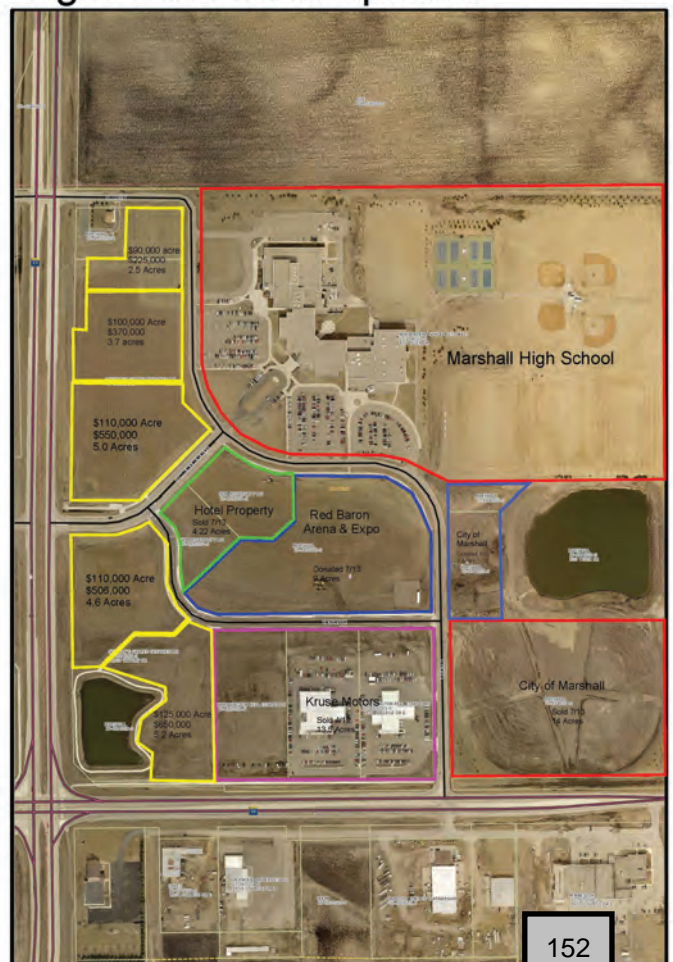

This map is drawn using Geo-Centric, GIS Interactive Mapping. This drawing is neither a legally recorded map nor a survey and is not intended to be used as one. This map is to be used for reference only and does not constitute a warranty.

TALL GRASS LIQUOR OUTLOT

Tall Grass Out Lot consists of .937 acres. It is located near the busy corner of Highway 59 and Boyer Drive. The City of Marshall would be willing to sell all or a portion of the cross-hatched area.



FOR SALE .937 Acres

Marshall EDA: 507.337.0802

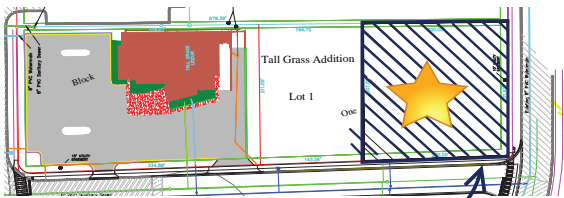

Liquor Store Out Lot



BLOCK 11

Block 11 consists of 11 parcels located on one of the busiest corners of Marshall at the intersection of College Drive and Main Street. Block 11 is within limits of the Downtown Central Business District.

Block 11 is part of the Central Business District which intends to preserve and enhance the city's central business district as the prime center for office and government employment, shopping and cultural activities.

The City of Marshall last year demoed two buildings on this site and purchased two additional parcels in which they intend to demo. The City is currently seeking proposals for the purchase and redevelopment of the eleven parcels of land totaling approximately 1.41 acres. Proposals due April 30th, 2019.





DISCOVER SW MN PARTNERSHIP

The City of Marshall has contracted with the Marshall Area Chamber of Commerce to provide staff to lead the marketing, recruitment and retention efforts for economic development in Marshall. The goal of the partnership is to create operational efficiencies, maximize limited financial resources, and create a more coordinated community effort to retain and grow the Marshall area. Another purpose is to foster relationships which allow contribution of our individual skills toward the common goal, and promote the individual strengths and unique characteristics of each entity to best match potential development prospects with sites and services to fit their needs.

BALATON

Largest Employers

Colonial Manor Nursing Home
City of Balaton
Ralco
trū Shrimp Company
Western Mutual

www.balatonmn.com

628
POPULATION



MUSTARD SEEDS KIDS

Mustard Seed Kids is a new child care center located in Balaton.

TRU SHRIMP COMPANY

trū Shrimp Company works to raise a safe and abundant food supply with a sustainable and environmentally responsible approach. Their work in Balaton includes a state of the art Balaton Bay Reef facility which is central point for training, research and development. They have received global accolades for their advancements in the aquaculture industry.

BROADBAND AND NATURAL GAS

2018 was a busy year in Balaton, as natural gas service (Minnesota Energy Resources) and fiber broadband (Woodstock Communications) was delivered to the entire community. With easy access to this critical infrastructure, Balaton is able to recruit and retain its citizens and businesses.

COTTONWOOD



1,239
POPULATION

Largest Employers

North Star Insurance
Lakeview Public Schools

www.cityofcottonwoodmn.com



The newly renovated Cottonwood Community Center provides an updated, more open facility, to better host large gatherings from wedding receptions, parties, meetings and community events.

FLORENCE



38
POPULATION

GARVIN



**BITTON'S
ROADHOUSE**
Restaurant & Bar with
a Banquet Hall and
Off-Sale Liquor Store.
Opened on
September 1, 2017.

133
POPULATION

GHENT



369
POPULATION

KB'S BAR & GRILL

Serves lunch, dinner, coffee and drinks. KB's Bar & Grill is known for their pizza and customer service.

LYND



LYNDWOOD CENTER is comprised of Southwest School of Dance, Prestige Gymnastics and Trev's Kitchen. Southwest School of Dance and Prestige Gymnastics offer a wide variety of classes for students of all ages. Trev's Kitchen, which offers organic food, specialty coffee and a selection of beer and wine in a relaxing atmosphere.

461
POPULATION

MINNEOTA



Photo by Byron Higgin Mascot Publisher

VETERAN'S PARK IN MINNEOTA

Veterans Park in Minneota stands in remembrance and honor of those who have served, or are currently serving, our country through their military service. The project was led by Legion Commander Jim Fink with assistance of the Minneota Legion and VFW.

1,371
POPULATION

Largest Employers

Minneota Manor Health Care
Minneota Public School District
Universal Forest Products

www.minneota.com



DOLLAR GENERAL

A new building was constructed and Dollar General opened its doors in 2018.

RUSSELL



MEADOWLAND

Meadowland Farmers Co-op has opened an agronomy location in Russell. Meadowland offers Technical support for seed placement and Service Calls including Corn, Soybean, Alfalfa, Small Grains, Specialty mixes, Lawn seed and Seed Treatments. In addition, they offer Bulk Seed handling and delivery, Custom Seed Treating, Yield checks, Data Processing, Variety plot data collection, and Variable rate seeding setup.

338
POPULATION

Largest Employers

First Independent Bank
Meadowland
Russell Municipal Liquor Store

www.cityofrussell.org

TAUNTON

DUKE'S CAFE

Brad and Courtney Norcutt became the new owners of Rusty's Café in Taunton. It is now called Duke's Corner Café. Along with some new specials, they will be keeping the menu mostly the same at the cafe. They will also continue offering catering for all occasions.



135
POPULATION

Largest Employer

State Bank of Taunton

TRACY

Largest Employer

Tracy Area Schools
Sandford Tracy Medical Center
City of Tracy
Premium Plant Services, Inc
Minnwest Bank South
Prairie View Health Care

www.tracymn.org

2,056
POPULATION

RED ROOSTER DEMOLITION -TRACY DEVELOPMENT CORPORATION FORMED

The Red Rooster restaurant closed its' doors in 2015. The Tracy Development Corp (TDC) was formed as a 501c4. The TDC, whose board is comprised of the highest levels of local leadership, is dedicated to the economic growth and vitality of the Tracy area to benefit their youth and citizens. The TDC purchased the 2.5-acre Red Rooster property in 2017 and then razed the building to pave the way for new development for the prime Highway 14 location. The TDC has also assisted with removing blighted homes to help improve community curb appeal. They also have their sights set on other exciting projects that will make a significant impact in their community.



Photo by Tracy Headlight Herald

 **TDC**
TRACY DEVELOPMENT CORPORATION

LYON COUNTY STATS

\$51,600
MEDIAN
HOUSEHOLD INCOME

25,699
LYON COUNTY
POPULATION

35.1
MEDIAN AGE

79.8%
LESS THAN 24
MINUTE COMMUTE

9,958
TOTAL
HOUSEHOLDS

81.1%
LABOR
EARNINGS



ACHIEVEMENTS

-  Minnesota ranked **#2** as **Best State** and ranked **#2** for **Quality of Life**.
—US News and World Report
www.usnews.com/news/best-states/minnesota
-  As a leader in industry, education, and technology, Marshall enjoys a regional reputation for economic vitality.
-  Marshall is taking an active role in developing strategies for hiring, retaining, and training the workers who will give businesses a competitive advantage by strengthening industry and education partnerships.
-  We boast many big-city amenities without the hassles. In Marshall, you'll find a safe community, cultural and recreational activities, and most importantly, the time to enjoy them all, because there is no such thing as commute time in this town we call one of the biggest small towns in Minnesota.
-  Our business community is more wired than most metropolitan areas and we have competitive services. Southwest MN is a forward thinking, business-friendly region with shovel ready sites welcoming you to join us.
-  WCCO **Best Hockey Rink** in Minnesota in 2017

STRONGER TOGETHER





CITY OF MARSHALL AGENDA ITEM REPORT

Meeting Date:	Tuesday, April 23, 2019
Category:	CONSENT AGENDA
Type:	ACTION
Subject:	Consider the annual adoption of a Resolution Declaring the Sounds of Summer as a Community Festival.
Background Information:	Sounds of Summer Committee has submitted a letter requesting that the City declare "The Sounds of Summer" celebration as a Community Festival. The Sounds of Summer is scheduled for Thursday, August 15, 2019 through Sunday, August 18, 2019.
Fiscal Impact:	None
Alternative/ Variations:	None Recommended
Recommendations:	Consider adoption of RESOLUTION NUMBER XXXX, SECOND SERIES, a resolution declaring the Sounds of Summer as a Community Festival.

RESOLUTION NUMBER _____, SECOND SERIES

AUTHORIZATION TO DECLARE SOUNDS OF SUMMER AS A COMMUNITY FESTIVAL

WHEREAS, the Sounds of Summer Committee is planning to entertain the residents of Marshall and the surrounding area; and

WHEREAS, everyone enjoys a great parade, open-air concerts, fun and exciting activities for all ages; and

WHEREAS, due to the fantastic community event and celebration that was held in the past by Schwan's the Chamber of Commerce did determine that we need to celebrate our home town of Marshall with a summer festival; and

WHEREAS, the Sounds of Summer Committee will be holding the Community Festival in August, 2018.

NOW, THEREFORE, BE IT RESOLVED, that the City Council declares the Sounds of Summer Community event scheduled for August 15, 2019 through August 18, 2019 as a "Community Festival".

Passed and adopted by the Common Council this 23rd day of April, 2019.

Mayor of the City of Marshall

ATTEST:

City Clerk



March 2019

To: Honorable Mayor and Council Members
Cc: Sharon Hanson, City Administrator

From: Marshall Sounds of Summer

We hereby request that you declare the Sounds of Summer celebration scheduled for Thursday August 15 thru Sunday August 18, 2019, A Community Festival.

Now in our eleventh year, our mission remains the same; family, friendly, free events that the entire family can enjoy. As our community celebration continues to grow, more and more families, organizations, and individuals are asking how they can become involved. For the past couple years, a new event called "Culture Fest" was held on Friday evening. This group of individuals are extremely happy to see the increases in participation as well as attendance.

Our grand festival parade will be on Saturday afternoon, and the free outdoor concert featuring two national bands, Matt Vee and the Killer Vees and then Pablo Cruise highlighting Saturday evening. On Sunday, the festival will conclude with a community wide praise service, and the always popular Marshall Fire Department splash party held at the Marshall Aquatic Center We encourage and thank you for your support of Sounds of Summer 2018!

Sincerely,

A handwritten signature in blue ink that reads "Carrie Jones".

Brock Klaith, Carrie Jones, Marc Klaith

Sounds of Summer Committee Officers

Two handwritten signatures in blue ink. The first signature reads "Brock Klaith" and the second signature reads "Marc Klaith".



CITY OF MARSHALL AGENDA ITEM REPORT

Meeting Date:	Tuesday, April 23, 2019
Category:	CONSENT AGENDA
Type:	ACTION
Subject:	Call for Public Hearing for Private Use of Public Streets and Parking Lots for Sounds of Summer – August 16-18, 2019.
Background Information:	<p>Attached is a request from the Sounds of Summer Committee requesting permission for the following:</p> <ul style="list-style-type: none"> - Entire Celebration: Closure of West College Drive (TH 19) from the corner of Main Street to Saratoga Street, and also closure of Marvin Schwan Memorial Drive from West College Drive (TH 19) to South 1st Street on Friday, August 16, 2019 from 3:00 p.m. to approximately 10:00 pm, and again on Saturday, August 17, 2019 from 6:00 am to Sunday, August 18, 2019, to approximately 3:00 am. to allow adequate time for clean up after the Saturday evening activities. Please see attached “Exhibit A”. - Closure of gravel parking lot adjacent to the Varsity Pub on Saturday, August 17, 2019 from approximately 6:00 am to approximately 6:00 pm. Please see attached “Exhibit A”. - Parade Line-Up: Closure of East Lyon Street, beginning at the corner of East Lyon Street and South Bruce Street to Jewett Street on Saturday, August 17, 2019 starting at approximately 12:00 noon to approximately 5:00 pm. Line-up would begin at 2:00 pm. Please see attached “Exhibit B”. - Parade: Closure of East Lyon Street from South Bruce Street to Main Street and closure of Main Street from East Lyon Street to North 6th Street Saturday, August 17, 2019 from 3:00 pm to approximately 6:00 pm. Parade would start at 4:00 pm with an estimated 5:30 pm end time. Please see attached “Exhibit B”. <p>In accordance with Section 62-6 of the Marshall City Code, any private use of public streets and parking lots on either a temporary or permanent basis should be considered by the Marshall City Council. Due to the magnitude of the proposed event and potential impact to the businesses adjacent to the areas that are being requested to be blockaded, City Staff would recommend that the City Council hold a public hearing on this request prior to granting final approval. In the past, the City’s Public Safety and Public Works Departments have been worked with applicants on the issues and public safety concerns that would have to be addressed as part of this request. In addition, it would be City Staff’s intent to have a representative from the Committee present at the hearing to provide a brief overview of the activities and events that are going to occur during the celebration.</p>
Fiscal Impact:	There will be costs involved for overtime for personnel for set-up and take-down of the detours, barricades, traffic control and street sweeping. Staff is proceeding with plans not to charge fees for this event based on past practice. Costs for operations attributed to the parade only are estimated at less than \$5,000.
Alternative/Variations:	City Council may direct to require fees for these operations to be billed by rates according to the Resolution of Fees and Rates as an amendment to the proposed “Action Recommendation”.
Recommendations:	that the Council call for a public hearing to be held on May 14, 2019 for the private use of public streets and parking lots for Sounds of Summer (August 16-18, 2019).

March 2019

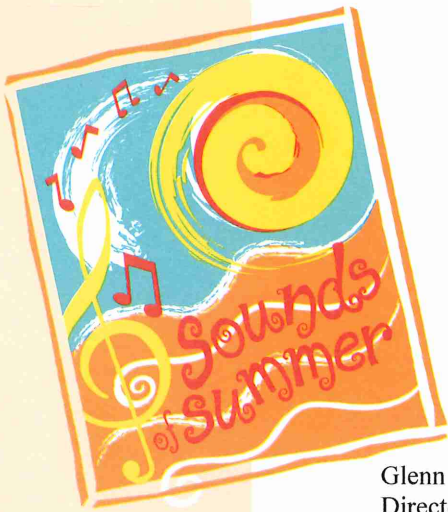

Glenn J. Olson P.E.
Director of Public Works
City of Marshall
344 W. Main St.
Marshall, MN 56258

Dear Glenn,

As members of the Marshall Sounds of Summer Planning Committee, we hereby request permission to close West College Drive from the corner of Main and College to Saratoga Street, and also Marvin Schwan Drive from College Drive to South 1st Street on Friday August 16, 2019 from 3:00 p.m. to 10:00 p.m., and on Saturday August 17, 2019 from 6:00 a.m. to Sunday August 18, 2019 to approximately 3:00 a.m. Please see exhibit "A." This would allow us adequate time for clean up after the Saturday evening activities. We would also like to request the closure of the gravel parking lot adjacent to the Varsity Pub on Saturday August 17th from 6:00 am to approximately 6:00 pm.

Our second request is to have permission to hold our Sounds of Summer Parade on Saturday August 17, 2019, along the same route as prior years. Line-up would begin at Jewett Street and East Lyon Street to Bruce Street, the start of the parade. It would proceed to East Main Street (TH59) in a Northwestern path to downtown Marshall and ending between 5th and 6th Streets. Line up would begin at 2:00 p.m. Parade would start at 4:00 p.m. with an estimated 5:30 p.m. end time, or if exceptionally large parade, could be 6:00 p.m. Please see exhibit "B." In the past it has been requested that we secure your permission as well as working with City and County Law Enforcement to temporarily close TH59 and TH68 through the parade route and to coordinate that with MNDOT. Again this year we would request to close Lyon Street, beginning at the corner of Lyon and Bruce to Jewett Street starting at 12:00 noon to approximately 5:00 p.m. Past years we have had numerous safety issues with traffic on this street while the parade units are lining up.

Please respond at your earliest convenience so we may proceed planning the remainder of our Sounds of Summer 2019 celebration. We would also be available to discuss these requests with you.

Any additional information you may need, please let us know.

Sincerely,
  

Brock Klaith, Carrie Jones, Marc Klaith
Marshall Sounds of Summer Committee Officers

cc. Jim Marshall, Marshall Chief Public Safety
Eric Wallen, Lyon County Sheriff
Dean Coudron, Public Works Superintendent

Sounds of Summer Exhibit "A"

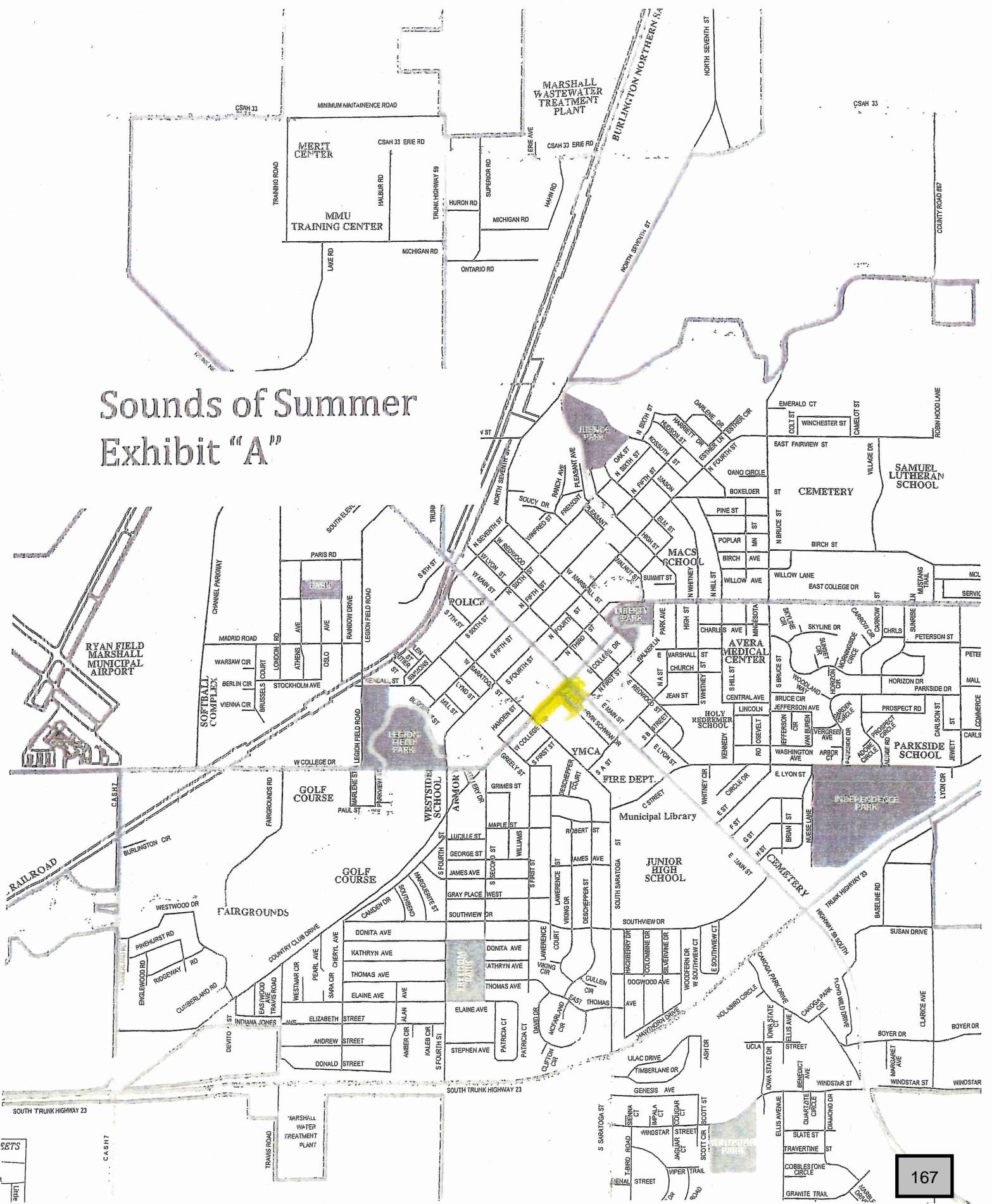

Sounds of Summer Exhibit "B"

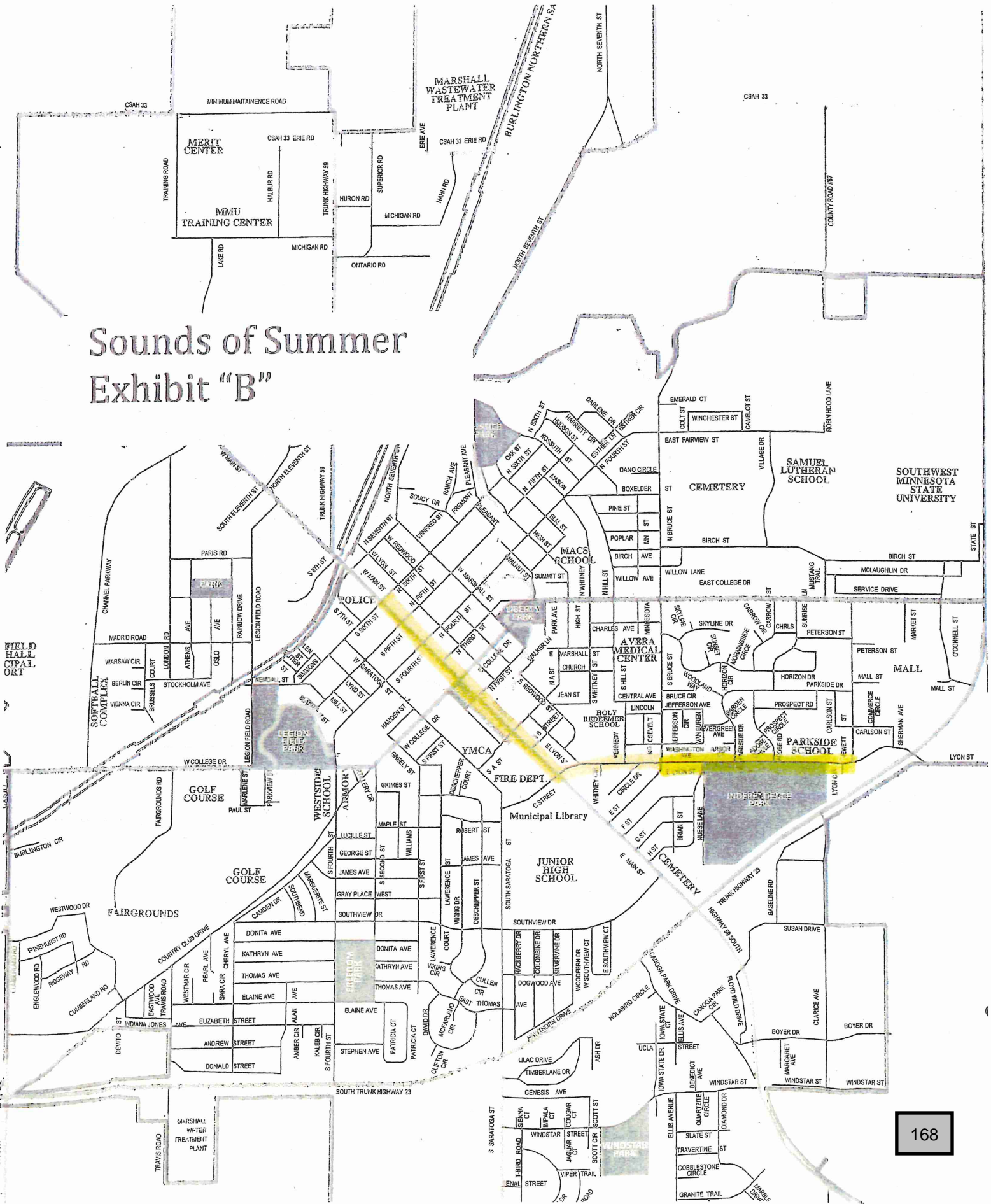

DETOUR SIGNING PLAN

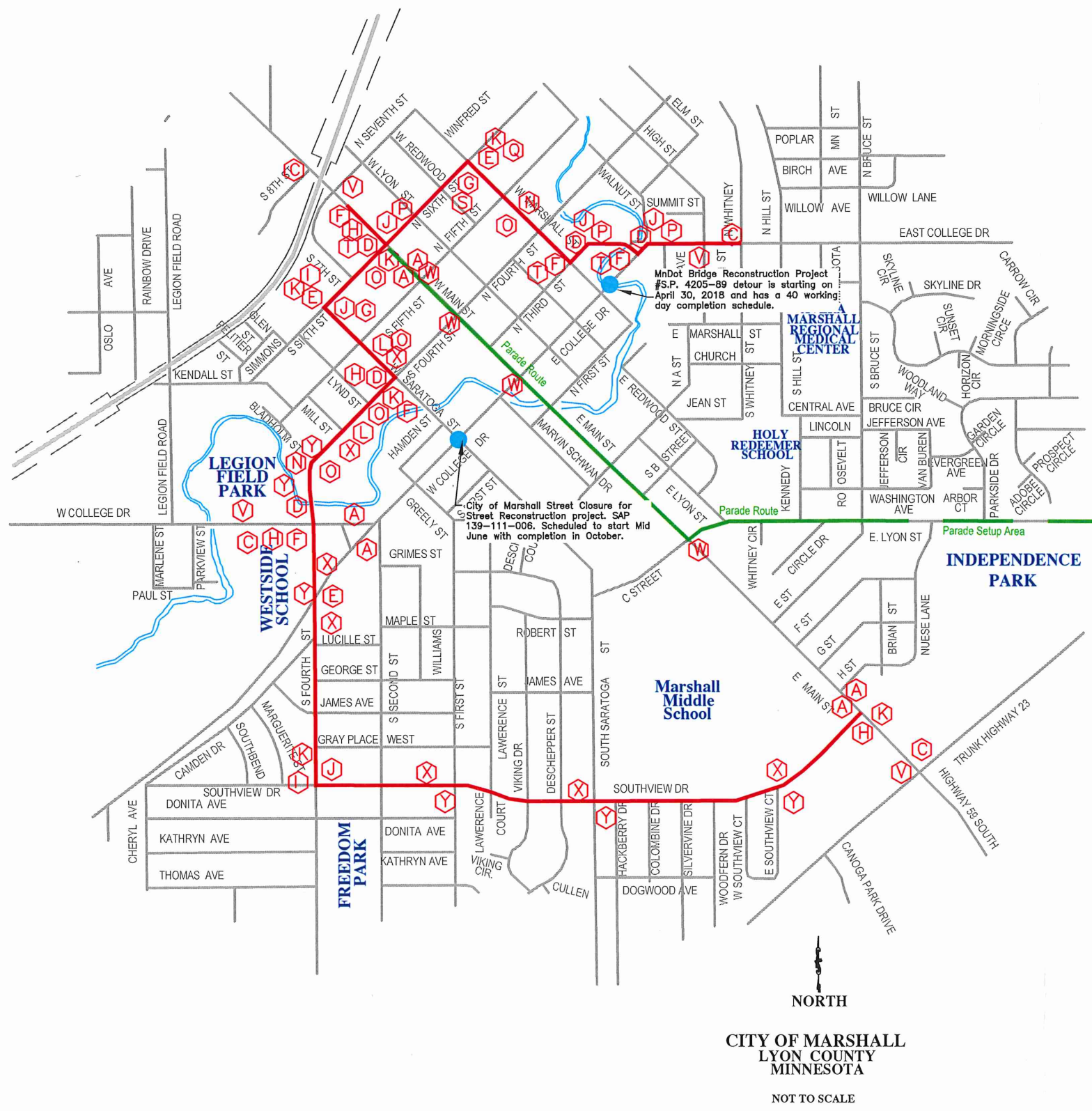

	R11-2 G20-2		M4-8 M3-1 M1-4 M5-1a (LEFT)		M4-8 M3-4a M1-5a M5-1a (LEFT)
FLASHERS NOT SHOWN					
	G20-2		M4-8 M3-1 M1-4 M5-1a (RIGHT)		M4-8 M3-4a M1-5a M5-1a (RIGHT)
FLASHERS NOT SHOWN					
	W20-2		M4-8 M3-4a M1-5a M6-3a		M4-8 M3-4a M1-5a M6-3a
*1500' FROM INT.			M4-8 M3-2a M1-5a M6-3a		M4-8 M3-2a M1-5a M5-1a (LEFT)
	M4-8 M3-4a M1-5a M5-1a (RIGHT)		M4-8 M3-4a M1-5a M6-3a		M4-8 M3-2a M1-5a M5-1a (RIGHT)
	M4-8 M3-4a M1-5a M5-1a (LEFT)		M4-8 M3-2a M1-5a M6-3a		M4-8 M3-2a M1-5a M6-3a
	M4-8 M3-2a M1-5a M5-1a (LEFT)		M4-8 M3-1 M1-4 M6-3		M4-8a
	M4-8 M3-2a M1-5a M5-1a (RIGHT)		M4-8 M3-3 M1-4 M5-1 (LEFT)		
	M4-8 M3-3 M1-4 M5-1 (RIGHT)				
	M4-8 M3-3 M1-4 M5-1 (LEFT)				
					Police
					*500' FROM INT.

ALL TRAFFIC CONTROL DEVICES SHALL CONFORM TO THE LATEST EDITION OF THE MINNESOTA MANUAL ON UNIFORM TRAFFIC CONTROL DEVICES, INCLUDING THE LATEST FIELD MANUAL FOR TEMPORARY TRAFFIC CONTROL ZONE LAYOUTS

ALL NECESSARY TRAFFIC CONTROL DEVICES AND DETOUR DEVICES ON THIS PROJECT SHALL BE THE RESPONSIBILITY OF THE CITY OF MARSHALL.
ALL TRAFFIC CONTROL DEVICES SHALL HAVE RETROREFLECTIVE SHEETING.

CITY ENGINEERS OFFICE
344 WEST MAIN STREET
MARSHALL, MINNESOTA
56258

Sounds of Summer Parade

Detour Plan **169**

DATE	REVISIONS
	DESCRIPTION

I HEREBY CERTIFY THAT THIS PLAN, SPECIFICATION OR REPORT WAS PREPARED BY ME OR UNDER MY DIRECT SUPERVISION AND THAT I AM A DULY LICENSED ENGINEER UNDER THE LAWS OF THE STATE OF MINNESOTA.

DATE _____ REGISTRATION NO. _____ 41557

DATE 4/26/2018	S.P. NO.
DRAWN BY K.R.J.	SHEET NO.



CITY OF MARSHALL AGENDA ITEM REPORT

Meeting Date:	Tuesday, April 23, 2019
Category:	NEW BUSINESS
Type:	ACTION
Subject:	Consider approval of a letter of support for the Marshall Cemetery Association
Background Information:	The Marshall Cemetery Association is requested a letter of support from the City Council regarding Minnesota House of Representatives Bill H.F. 2620 and Minnesota senate Bill S.F. 2647 – Charitable Farmland Property Tax Exemption.
Fiscal Impact:	The potential for the Marshall Cemetery to be exempt from property taxes.
Alternative/ Variations:	
Recommendations:	To approve and submit a letter of support for the Marshall Cemetery Association.

Marshall Cemetery Association
703 Lawrence Street
Marshall, MN 56258

April 15, 2019

Marshall City Council
Marshall City Hall
Marshall, MN 56258

Dear Council Members,

We are the Board of Directors of the non-profit Marshall Cemetery Association, which owns and operates the Marshall Cemetery. The Cemetery is a public cemetery, serving the communities in and around Marshall, MN. The cemetery owns a total of 47 acres, 20 acres of which are currently used for the cemetery proper. Twelve acres are maintained in grassed buffers and 15 acres are used for cropland. In the 122 years since the Marshall Cemetery Association was incorporated, those acres not needed for burials have always been farmed and the proceeds used solely to operate and maintain the cemetery.

In 2013, for the first time, the Marshall City Assessor determined that the cropland was subject to local property taxes. The assessed taxes, based on property classifications determined by the assessor, have been as high as 95% of the rental income we received from the cropland. Even with the increase in rent we were able to negotiate this year, the property taxes will be over to 75% of our rental income.

Minnesota House of Representatives Bill **H.F. 2620** and Minnesota Senate Bill **S. F. 2647 - Charitable Farmland Property Tax Exemption Established** directly address this issue, making property owned by a public hospital, house of worship or cemetery and used for the production of agricultural products exempt from property taxes, provided that any proceeds from the sale of the agricultural products are used to support the mission of the public hospital, house of worship or cemetery.

The assessed property taxes have had a significant negative impact on our immediate and long-term ability to operate and maintain the cemetery. If we are unable to continue, by law the cemetery would become the responsibility of either the city of Marshall or Lyon County (or both)—at a much higher annual cost than the few thousand dollars collected in property taxes.

Financially, we believe it would be in the long-term best interests of both the Cemetery Association and our local governments if the cemetery was not assessed property taxes on that portion of the cemetery used for cropland. Unfortunately, current law does not allow it. House Bill **H.F. 2620** and Senate Bill **SF. 2647** would correct that, and as representatives of the Marshall Cemetery Association, we strongly urge you to support passage of these bills.

Thank you for your support.

Sincerely,

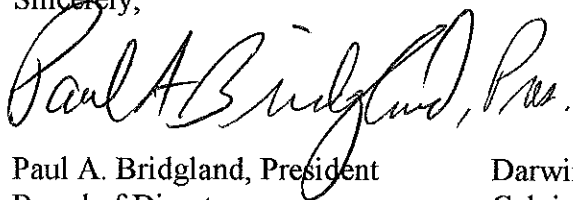

Paul A. Bridgland, President
Board of Directors
Marshall Cemetery Association

Darwin Leek, Vice-President
Calvin Barnett
James Jacobson
Ellie Sprik

Lyle Moseng, Secretary-Treasurer
Willard Engel
David Sprik
Randal Thordson

This Document can be made available in alternative formats upon request

State of Minnesota

HOUSE OF REPRESENTATIVES

NINETY-FIRST SESSION

H. F. No. 2620

03/20/2019 Authored by Drazkowski
The bill was read for the first time and referred to the Committee on Taxes

1.1 A bill for an act
1.2 relating to taxation; property; establishing property tax exemption for charitable
1.3 farmland; amending Minnesota Statutes 2018, section 272.02, by adding a
1.4 subdivision.

1.5 BE IT ENACTED BY THE LEGISLATURE OF THE STATE OF MINNESOTA:

1.6 Section 1. Minnesota Statutes 2018, section 272.02, is amended by adding a subdivision
1.7 to read:

1.8 Subd. 102. Charitable farmland. Property owned by an organization exempt under
1.9 subdivision 4, 6, or 58 and used in the production of agricultural products as defined in
1.10 section 273.13, subdivision 23, is exempt, provided that any proceeds from the sale of the
1.11 agricultural products are used to support the mission of an organization exempt under
1.12 subdivision 4, 6, or 58.

1.13 EFFECTIVE DATE. This section is effective beginning with property taxes payable
1.14 in 2020.



CITY OF MARSHALL AGENDA ITEM REPORT

Meeting Date:	Tuesday, April 23, 2019
Category:	NEW BUSINESS
Type:	ACTION
Subject:	Commerce Industrial Park Second Addition Dedication of Public Roadway and Utility Easements
Background Information:	<p>The background information was previously provided and summarized for the Housing and Redevelopment Authority action item. Recent as-built survey has indicated slight discrepancies between the location of the constructed roadway and the roadway as previously platted. It appears that the intersections with Michigan Road and the various avenues within Commerce Industrial Park Second Addition do not meet at true 90° angles. There is a slight curvature at each intersection. As such, it is necessary to require a land transfer and subsequent dedication of public roadway and street uses.</p> <p>HRA has previously executed a deed describing land descriptions and easement descriptions. HRA has deeded the described property to the City of Marshall with the understanding that the property would be dedicated for public roadway and utility easement purposes.</p> <p>City staff is recommending that the appropriate resolution be approved dedicating roadway and utilities and requiring that the resolution be recorded in the office of the Lyon County Recorder for verification of dedicated roadway and utilities.</p>
Fiscal Impact:	The applicant will be billed for all direct costs related to the roadway and utility dedication process.
Alternative/ Variations:	None recommended.
Recommendations:	Consider and approve Resolution No. ____, Second Series authorizing dedication of City-owned property for public roadway and street use purposes forever and dedicating utility easements for public use forever.

Certificate of Survey

A part of the Blocks 4 & 5, Commerce Park 2nd Addition
in the City of Marshall, Lyon County, Minnesota.

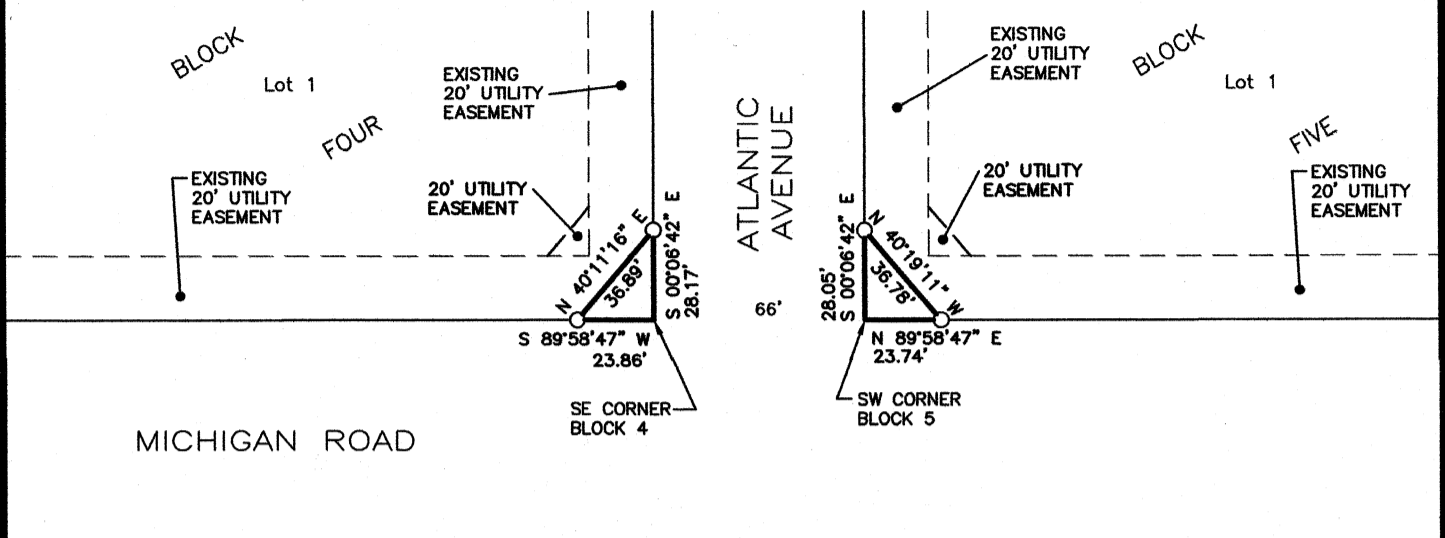

LAND DESCRIPTION IN BLOCK 4

All that part of Lot 1, Block 4 of Commerce Industrial Park Second Addition, in the City of Marshall, as filed and recorded in the office of the County Recorder in and for Lyon County, Minnesota, being more particularly described as follows:

Beginning at the southeast corner of said Block 4; thence South 89 degrees 58 minutes 47 seconds West, bearing based on Lyon County Coordinate System (1996 Adj.), along the south line of said Block 4, a distance of 23.86 feet; thence North 40 degrees 11 minutes 16 seconds East a distance of 36.89 feet, to a point on the east line of said Block 4; thence South 00 degrees 06 minutes 42 seconds East, along said east line a distance of 28.17 feet, to the point of beginning.

EASEMENT DESCRIPTION IN BLOCK 4

A 20 foot utility easement located in Lot 1, Block 4 of Commerce Industrial Park Second Addition, in the City of Marshall, as filed and recorded in the office of the County Recorder in and for Lyon County, Minnesota, lying northwesterly and adjacent to the following described line:

Commencing at the southeast corner of said Block 4; thence South 89 degrees 58 minutes 47 seconds West, bearing based on Lyon County Coordinate System (1996 Adj.), along the south line of said Block 4, a distance of 23.86 feet, to the point of beginning of said line to be described; thence North 40 degrees 11 minutes 16 seconds East a distance of 36.89 feet, to a point on the east line of said Block 4, said line there terminating.

LAND DESCRIPTION IN BLOCK 5

All that part of Lot 1, Block 5 of Commerce Industrial Park Second Addition, in the City of Marshall, as filed and recorded in the office of the County Recorder in and for Lyon County, Minnesota, being more particularly described as follows:

Beginning at the southwest corner of said Block 5; thence North 89 degrees 58 minutes 47 seconds East, bearing based on Lyon County Coordinate System (1996 Adj.), along the south line of said Block 5, a distance of 23.74 feet; thence North 40 degrees 19 minutes 11 seconds West a distance of 36.78 feet, to a point on the west line of said Block 5; thence South 00 degrees 06 minutes 42 seconds East, along said west line, a distance of 28.05 feet, to the point of beginning.

EASEMENT DESCRIPTION IN BLOCK 5

A 20 foot utility easement located in Lot 1, Block 5 of Commerce Industrial Park Second Addition, in the City of Marshall, as filed and recorded in the office of the County Recorder in and for Lyon County, Minnesota, lying northeasterly and adjacent to the following described line:

Commencing at the southwest corner of said Block 5; thence North 89 degrees 58 minutes 47 seconds East, bearing based on Lyon County Coordinate System (1996 Adj.), along the south line of said Block 5, a distance of 23.74 feet, to the point of beginning of said line to be described; thence North 40 degrees 19 minutes 11 seconds West a distance of 36.78 feet, to a point on the west line of said Block 5, said line there terminating.

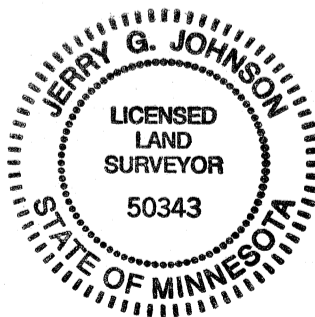

SURVEYOR'S CERTIFICATION

I hereby certify that this plan, specification, or report was prepared by me or under my direct supervision and that I am a duly Licensed Land Surveyor under the laws of the State of Minnesota.

[Signature]
JERRY G. JOHNSON LICENSE NO: 50343

DATE: APRIL 17, 2019

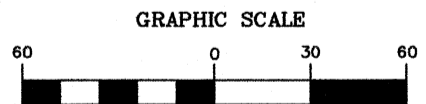

(IN FEET)
1 inch = 60 feet

LEGEND

These standard symbols will be found in the drawing.

- MONUMENTS FOUND
- MONUMENTS SET- 5/8" IRON W/SEAL #50343

Prepared for City of Marshall

Prepared by
Bueltel-Moseng Land Surveying, Inc.
Marshall, MN 56258 Ph. 507-532-9043
PROJECT NO. 18-2761A-1

Certificate of Survey

A part of the Blocks 5 & 6, Commerce Park 2nd Addition
in the City of Marshall, Lyon County, Minnesota.

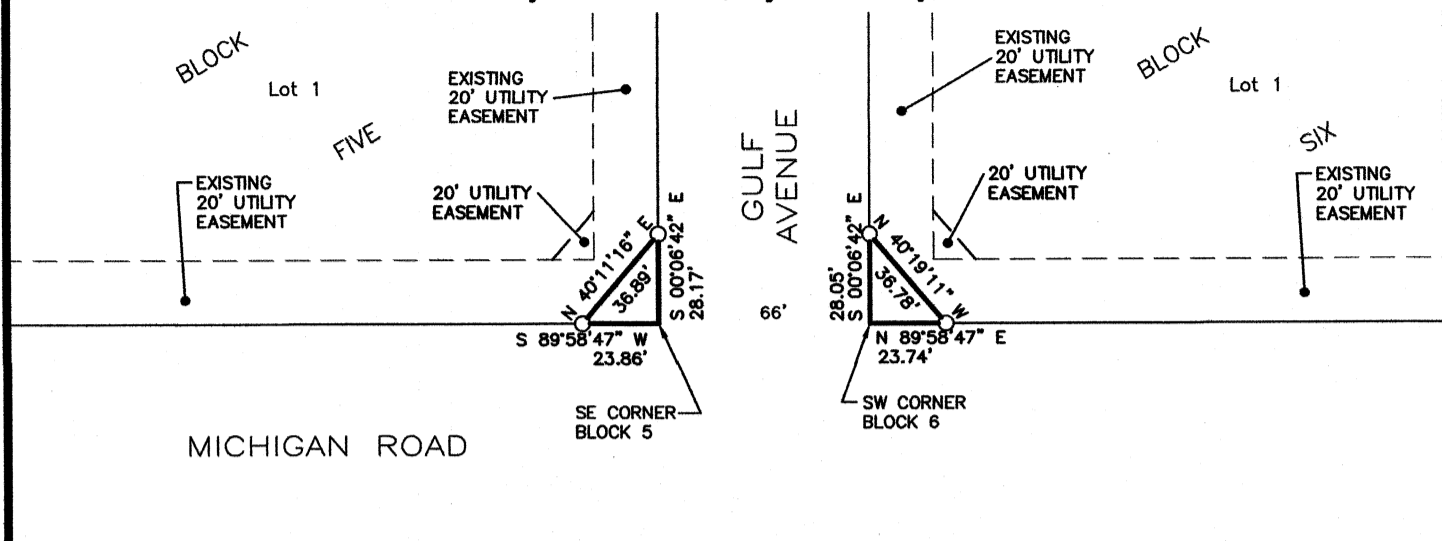

LAND DESCRIPTION IN BLOCK 5

All that part of Lot 1, Block 5 of Commerce Industrial Park Second Addition, in the City of Marshall, as filed and recorded in the office of the County Recorder in and for Lyon County, Minnesota, being more particularly described as follows:

Beginning at the southeast corner of said Block 5; thence South 89 degrees 58 minutes 47 seconds West, bearing based on Lyon County Coordinate System (1996 Adj.), along the south line of said Block 5, a distance of 23.86 feet; thence North 40 degrees 11 minutes 16 seconds East a distance of 36.89 feet, to a point on the east line of said Block 5; thence South 00 degrees 06 minutes 42 seconds East, along said east line a distance of 28.17 feet, to the point of beginning.

EASEMENT DESCRIPTION IN BLOCK 5

A 20 foot utility easement located in Lot 1, Block 5 of Commerce Industrial Park Second Addition, in the City of Marshall, as filed and recorded in the office of the County Recorder in and for Lyon County, Minnesota, lying northwesterly and adjacent to the following described line:

Commencing at the southeast corner of said Block 5; thence South 89 degrees 58 minutes 47 seconds West, bearing based on Lyon County Coordinate System (1996 Adj.), along the south line of said Block 5, a distance of 23.86 feet, to the point of beginning of said line to be described; thence North 40 degrees 11 minutes 16 seconds East a distance of 36.89 feet, to a point on the east line of said Block 5 said line there terminating.

LAND DESCRIPTION IN BLOCK 6

All that part of Lot 1, Block 6 of Commerce Industrial Park Second Addition, in the City of Marshall, as filed and recorded in the office of the County Recorder in and for Lyon County, Minnesota, being more particularly described as follows:

Beginning at the southwest corner of said Block 6; thence North 89 degrees 58 minutes 47 seconds East, bearing based on Lyon County Coordinate System (1996 Adj.), along the south line of said Block 6, a distance of 23.74 feet; thence North 40 degrees 19 minutes 11 seconds West a distance of 36.78 feet, to a point on the west line of said Block 6; thence South 00 degrees 06 minutes 42 seconds East, along said west line, a distance of 28.05 feet, to the point of beginning.

EASEMENT DESCRIPTION IN BLOCK 6

A 20 foot utility easement located in Lot 1, Block 6 of Commerce Industrial Park Second Addition, in the City of Marshall, as filed and recorded in the office of the County Recorder in and for Lyon County, Minnesota, lying northeasterly and adjacent to the following described line:

Commencing at the southwest corner of said Block 6; thence North 89 degrees 58 minutes 47 seconds East, bearing based on Lyon County Coordinate System (1996 Adj.), along the south line of said Block 6, a distance of 23.74 feet, to the point of beginning of said line to be described; thence North 40 degrees 19 minutes 11 seconds West a distance of 36.78 feet, to a point on the west line of said Block 6, said line there terminating.

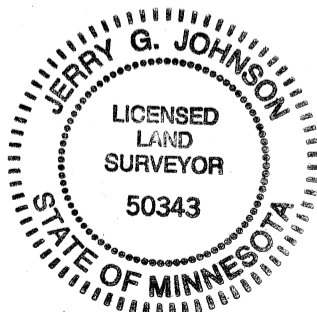

SURVEYOR'S CERTIFICATION

I hereby certify that this plan, specification, or report was prepared by me or under my direct supervision and that I am a duly Licensed Land Surveyor under the laws of the State of Minnesota.

[Signature]
JERRY G. JOHNSON LICENSE NO: 50343

DATE: APRIL 17, 2019

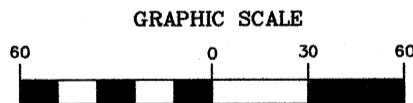

(IN FEET)
1 inch = 60 feet

LEGEND

These standard symbols will be found in the drawing.

- MONUMENTS FOUND
- MONUMENTS SET- 5/8" IRON W/SEAL #50343

Prepared for City of Marshall

Prepared by
Bueltel-Moseng Land Surveying, Inc.
Marshall, MN 56258 Ph. 507-532-9043
PROJECT NO. 18-2761A-2

Certificate of Survey

A part of Lot 1, Block 4, and Outlot E of Commerce Industrial Park 2nd Addition in the City of Marshall, Lyon County, Minnesota.

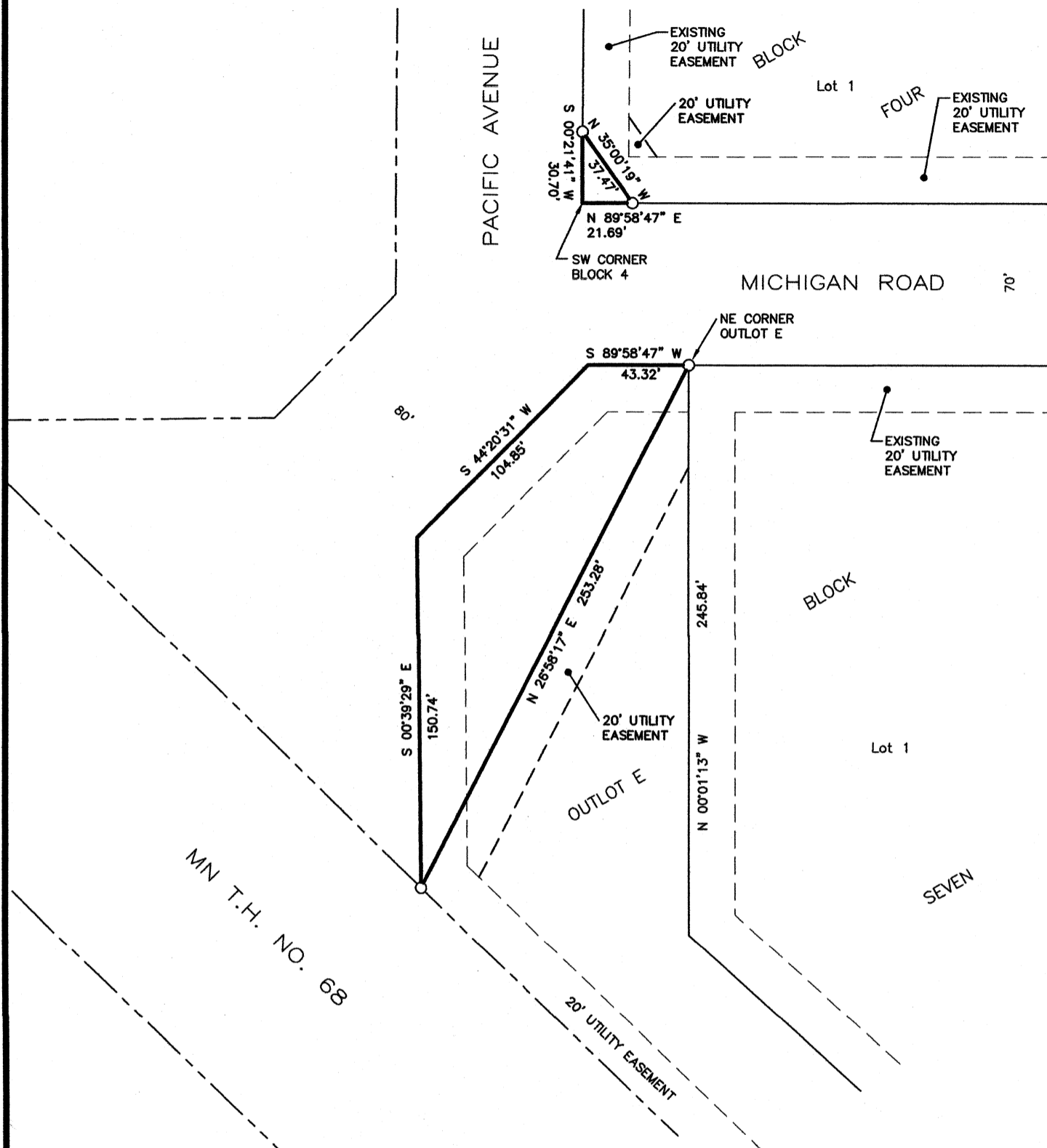

MN T.H. NO. 68

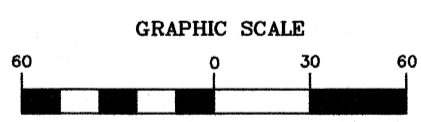
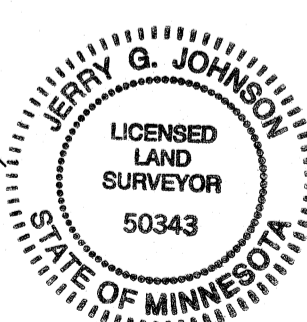

(IN FEET)
1 inch = 60 feet

LEGEND

- These standard symbols will be found in the drawing.
- MONUMENTS FOUND
 - MONUMENTS SET- 5/8" IRON W/SEAL #43844

Prepared for City of Marshall

Prepared by
Bueltel-Moseng Land Surveying, Inc.
Marshall, MN 56258 Ph. 507-532-9043
PROJECT NO. 18-2761B

SURVEYOR'S CERTIFICATION

I hereby certify that this plan, specification, or report was prepared by me or under my direct supervision and that I am a duly Licensed Land Surveyor under the laws of the State of Minnesota.

[Signature]
JERRY G. JOHNSON LICENSE NO: 50343

DATE: APRIL 17, 2019

SHEET 1 OF 2

Certificate of Survey

A part of Lot 1, Block 4, and Outlot E of Commerce Industrial Park 2nd Addition in the City of Marshall, Lyon County, Minnesota.

LAND DESCRIPTION IN BLOCK 4

All that part of Lot 1, Block 4 of Commerce Industrial Park Second Addition, in the City of Marshall, as filed and recorded in the office of the County Recorder in and for Lyon County, Minnesota, being more particularly described as follows:

Beginning at the southwest corner of said Block 4; thence North 89 degrees 58 minutes 47 seconds East, bearing based on Lyon County Coordinate System (1996 Adj.), along the south line of said Block 4, a distance of 21.69 feet; thence North 35 degrees 00 minutes 19 seconds West a distance of 37.47 feet, to a point on the west line of said Block 4; thence South 00 degrees 21 minutes 41 seconds West, along said west line, a distance of 30.70 feet, to the point of beginning.

EASEMENT DESCRIPTION IN BLOCK 4

A 20 foot utility easement located in Lot 1, Block 4 of Commerce Industrial Park Second Addition, in the City of Marshall, as filed and recorded in the office of the County Recorder in and for Lyon County, Minnesota, lying northeasterly and adjacent to the following described line:

Commencing at the southwest corner of said Block 4; thence North 89 degrees 58 minutes 47 seconds East, bearing based on Lyon County Coordinate System (1996 Adj.), along the south line of said Block 4, a distance of 21.69 feet, to the point of beginning of said line to be described; thence North 35 degrees 00 minutes 19 seconds West a distance of 37.47 feet, to a point on the west line of said Block 4, said line there terminating.

LAND DESCRIPTION IN OUTLOT E

All that part of Outlot E of Commerce Industrial Park Second Addition, in the City of Marshall, as filed and recorded in the office of the County Recorder in and for Lyon County, Minnesota, being more particularly described as follows:

Beginning at the northeast corner of said Outlot E; thence South 89 degrees 58 minutes 47 seconds West, bearing based on Lyon County Coordinate System (1996 Adj.), along the north line of said Outlot E, a distance of 43.32 feet, to a corner of said Outlot E; thence South 44 degrees 20 minutes 31 seconds West, along the northwest line of said Outlot E, a distance of 104.85 feet, to a corner of said Outlot E; thence South 00 degrees 39 minutes 29 seconds East, along the west line of said Outlot E, a distance of 150.74 feet, to a corner of said Outlot E; thence North 26 degrees 58 minutes 17 seconds East a distance of 253.28 feet, to the point of beginning.

EASEMENT DESCRIPTION IN OUTLOT E

A 20 foot utility easement located in Outlot E of Commerce Industrial Park Second Addition, in the City of Marshall, as filed and recorded in the office of the County Recorder in and for Lyon County, Minnesota, lying southeasterly and adjacent to the following described line:

Beginning at the northeast corner of said Outlot E; thence South 26 degrees 58 minutes 17 seconds West, bearing based on Lyon County Coordinate System (1996 Adj.), a distance of 253.28 feet, to a corner of said Outlot E, said line there terminating.

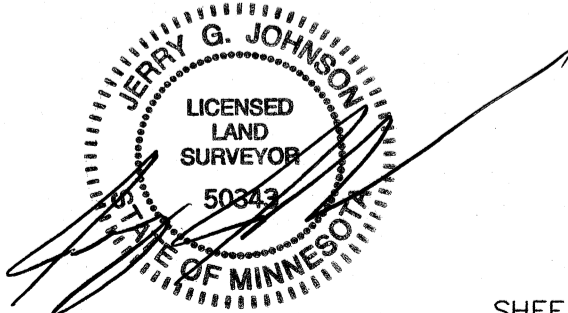

Prepared for City of Marshall

Prepared by
Bueltel-Moseng Land Surveying, Inc.
Marshall, MN 56258 Ph. 507-532-9043
PROJECT NO. 18-2761B

SHEET 2 OF 2

RESOLUTION NO. _____, SECOND SERIES

RESOLUTION DEDICATING CITY-OWNED PROPERTY FOR PUBLIC ROADWAY AND STREET USE PURPOSES FOREVER AND DEDICATING UTILITY EASEMENTS FOR PUBLIC USE FOREVER

WHEREAS, the City of Marshall has recently received real property pursuant to Quit Claim Deed from the City of Marshall Housing and Redevelopment Authority, also known as Housing and Redevelopment Authority in and for the City of Marshall, Minnesota, as Grantor; and

WHEREAS, the Quit Claim Deed referenced above transferred property as described on surveys attached to said deed to transfer land descriptions and utility easement descriptions therein; and

WHEREAS, the maps attached to said Quit Claim Deed are hereby attached to this resolution describing the property conveyed therein; and

WHEREAS, said deed requested that the land descriptions for said premises be dedicated for public roadway and street use purposes forever. Further, said descriptions defining the utility easements also requested that the easements be dedicated for public use forever; and

WHEREAS, the City Council for the City of Marshall hereby deems the request for dedication of public roadway and public utilities to be reasonable.

NOW, THEREFORE, BE IT RESOLVED, as follows:

1. Officials of the City of Marshall hereby dedicate the land described properties as attached are hereby dedicated and donated for public roadway and public street use purposes forever. The utility easement described property as attached hereto are hereby dedicated and donated for public use forever.
2. That a certified copy of this resolution be filed with the office of the Lyon County Recorder and that the resolution be recorded to confirm the dedication of property as herein described.

Passed and Adopted by the Common Council this 23rd day of April, 2019.

CITY OF MARSHALL

By: Robert J. Byrnes
Its: Mayor

ATTEST:

By: Kyle Box
Its: City Clerk

THIS INSTRUMENT WAS DRAFTED BY:

QUARNSTROM & DOERING, P.A.
MARSHALL CITY ATTORNEY
By: Dennis H. Simpson
109 South Fourth Street
Marshall, MN 56258
(507) 537-1441



CITY OF MARSHALL AGENDA ITEM REPORT

Meeting Date:	Tuesday, April 9, 2019
Category:	COUNCIL REPORTS
Type:	INFO
Subject:	Commission/Board Liaison Reports
Background Information:	<p>Byrnes - Fire Relief Association and Regional Development Commission</p> <p>Schafer - Airport Commission, MERIT Center Board, City Council-County Board/Library Agreement & Operations Southwest Minnesota Amateur Sports Commission and SW Minnesota Emergency Communication Board</p> <p>Meister -Community Services Advisory Board, Cable Commission and Economic Development Authority</p> <p>Bayerkohler - Public Housing Commission, Planning Commission and Capital Equipment Review Committee</p> <p>DeCramer – Economic Development Authority and Utilities Commission</p> <p>Labat - Library Board, Police Advisory Board and Convention and Visitors Bureau</p> <p>Lozinski - Adult Community Center Commission and Joint Law Enforcement Center Management Committee and Marshall Area Transit</p>
Fiscal Impact:	
Alternative/ Variations:	
Recommendations:	



Rescuer

Southview Drive



Wiking



BUILDING PERMIT LIST

April 23, 2019

APPLICANT	LOCATION ADDRESS	DESCRIPTION OF WORK	VALUATION
Countrywide Contracting, Inc	507 ELIZABETH ST	EXTERIOR REMODEL	38,900.00
FURN USA MN MARSHALL LLC	1001 HIGHWAY 23 N	BUILDING ADDITION & REMOI	360,000.00
VANLEEUEW CONSTRUCTION LLC	703 ELAINE AVE	RE-ROOFING	9,900.00
VANLEEUEW CONSTRUCTION LLC	406 GENESIS AVE	RE-ROOFING	8,500.00
VANLEEUEW CONSTRUCTION LLC	504 MERCEDES DR	RE-ROOFING	16,800.00
YVONNE & RONALD LOUWAGIE TRSTE, YVONN	234 HILL ST N	EXTERIOR REMODEL	9,500.00
VELDHUISEN, KEVIN R & ANNE T	103 HIGH ST S	WINDOWS / DOORS	10,000.00
LINDSAY, DEAN T & MARY G	600 KOSSUTH AVE	OVERHEAD GARAGE DOOR	2,500.00
KNIEFF, BRUCE A & KATHLEEN A	506 BLADHOLM AVE	Windows	1,500.00
MIKE BUYSSE CONSTRUCTION, INC.	1102 CHERYL AVE	RE-ROOFING	6,000.00
GARY VLAMINCK CONSTRUCTION	407 7TH ST N	INTERIOR & EXTERIOR REMC	7,000.00
POSSAIL, CLARENCE & GLENYCE	1221 PATRICIA CT	OVERHEAD GARAGE DOOR	1,400.00
CARLA A. ROHLIK (HAMMER'S AWAY, INC.	605 THOMAS AVE W	RE-ROOFING	5,900.00
JOHNSON, AMANDA J & LANCE D	613 LAWERENCE ST	RE-ROOFING	11,400.00
GLADIS PROPERTIES LLC, JEFF	100 HILL ST S	RE-SIDING	10,000.00
CARLA A. ROHLIK (HAMMER'S AWAY, INC.	602 CADILLAC RD	RE-ROOFING	8,400.00
BABCOCK CONSTRUCTION	110 RANCH AVE	INTERIOR & EXTERIOR REMC	16,200.00
Straight-up Builders LLC	410 LYON ST E	INTERIOR & EXTERIOR REMC	10,000.00
BRANDT, TRAVIS & NICOLE	303 JAMES AVE W	RE-ROOFING	7,000.00
MICHAEL SLAGEL CONSTRUCTION LLC	1304 ELLIS AVE	OVERHEAD GARAGE DOOR	1,100.00
RAASCH, PATRICK A	232 HILL ST N	INTERIOR & EXTERIOR REMC	1,500.00
BLADHOLM CONSTRUCTION, INC.	1105 LAKE RD	INTERIOR REMODEL	10,000.00



PLUMBING PERMIT LIST
April 23, 2019

APPLICANT	LOCATION ADDRESS	DESCRIPTION OF WORK	VALUATION
TRIO PLUMBING & HEATING	103 HIGH ST S	INTERIOR REMODEL	3,500.00

City of Marshall, Minnesota
Investments
3/31/2019

	Amount	Interest Rate
OTHER INVESTMENTS:		
ACCOUNTS PAYABLE	13,513,878.00	0.00%
ACCOUNTS PAYABLE INTEREST BEARING - SWEEP	4,454,628.28	2.31%
GENERAL FUND/EDA/FIRE DEPT. SCHOLARSHIP	7,437,236.10	2.13%
GENERAL FUND AGENCY ACCT.	2,585,757.91	
WASTEWATER - CAPITAL RES. TRUST ACCT.	2,722,109.36	
ENDOWMENT FUND - AVERA	2,062,020.14	
CAPITAL PROJECTS - MONEY MARKET	2,031,983.21	2.00%
MSA/LIQUOR/SURFACE WATER - MONEY MKT.	2,080,087.34	2.00%
SPECIAL REVENUE - TIF - MONEY MARKET	4,011,365.99	2.00%
DEBT SERVICE - MONEY MARKET	4,089,558.90	2.00%
SPECIAL REVENUE - MONEY MARKET	2,282,598.39	2.00%
TOTAL OTHER INVESTMENTS	<u>47,271,223.62</u>	

VENDOR	NAME / I.D.	DESC	CHECK TYPE	CHECK DATE	DISCOUNT	AMOUNT	CHECK NO#	CHECK AMOUNT
0658	AP DESIGN I-70244	BOARD NAME PLATE	R	4/09/2019		15.00CR	112653	15.00
0875	COMPUTER MAN INC I-280730 I-280732	RECEIPTPRINTERMD UPGRADEOUTREACHLAPTOP	R	4/09/2019		315.00CR 179.00CR	112654 112654	494.00
1271	HENLE PRINTING COMPANY I-158966 I-158967	DIGITALBKMARKS MNDRIVERSMANUAL	R	4/09/2019		90.87CR 68.94CR	112655 112655	159.81
1545	LYON COUNTY HIGHWAY DEPARTMENT I-201904083361	VANGASMARCH	R	4/09/2019		62.61CR	112656	62.61
1958	NORTHERN BUSINESS PRODUCTS, INC I-3864390	SUPPLIES	R	4/09/2019		88.67CR	112657	88.67
2318	SOUTHWEST SANITATION INC. I-201904083363	SRVC03/01-03/31	R	4/09/2019		74.42CR	112658	74.42
2351	STAR TRIBUNE I-201904083360	SRVC04/14/19-04/1219	R	4/09/2019		512.72CR	112659	512.72
3597	PAAPE DISTRIBUTING CO I-006464	SNOWMELTSIDEWALK	R	4/09/2019		47.50CR	112660	47.50
3819	DACOTAH PAPER CO I-34034 I-37147 I-40492	BLDG. SUPPLIES BLDG SUPPLIES BLDG SUPPLIES	R	4/09/2019		52.62CR 53.62CR 127.20CR	112661 112661 112661	233.44
4118	WALMART BUSINESS I-908400148350 I-909300557877	FRIENDSPROGRAMS EARLYLEARNINGKITS GRANT	R	4/09/2019		47.22CR 169.14CR	112662 112662	216.36
4489	VERIZON WIRELESS I-9825710798	SRVC03/09-04/08	R	4/09/2019		60.88CR	112663	60.88
4549	A & B BUSINESS, INC I-IN600281	SRVC03/21-04/20	R	4/09/2019		412.06CR	112664	412.06
4552	INGRAM LIBRARY SERVICES I-39077688 I-39152625 I-39162358 I-39195217 I-39209646 I-39263473 I-39296307 I-39336323 I-39365909 I-39378657	MATERIALS MATERIALS MATERIALS MATERIALS MATERIALS MATERIALS MATERIALS MATERIALS MATERIALS MATERIALS	R	4/09/2019		91.41CR 172.34CR 75.05CR 99.50CR 54.24CR 96.86CR 212.24CR 1,867.48CR 182.28CR 39.90CR	112665 112665 112665 112665 112665 112665 112665 112665 112665 112665	

VENDOR	NAME / I.D.	DESC	CHECK TYPE	CHECK DATE	DISCOUNT	AMOUNT	CHECK NO#	CHECK AMOUNT
	I-39457692	MATERIALS	R	4/09/2019		256.49CR	112665	
	I-39467613	MATERIALS	R	4/09/2019		71.98CR	112665	3,219.77
VOID	VOID CHECK		V	4/09/2019			112666	**VOID**
4570	AMAZON							
	I-453345984495	DVD	R	4/09/2019		18.17CR	112667	18.17
4573	DEMCO							
	I-6579560	PROCESSINGSUPPLIES/FRIENDS	R	4/09/2019		1,179.68CR	112668	1,179.68
4740	WELLS FARGO-LIBRARY							
	I-201904083356	WELLS FARGO-LIBRARY	R	4/09/2019		395.10CR	112669	395.10
4980	MENARDS INC							
	I-36877	BLDGSUPPLIES	R	4/09/2019		11.47CR	112670	
	I-37203	STAFF COATRACK	R	4/09/2019		16.78CR	112670	28.25
5384	WALL STREET JOURNAL							
	I-201904013336	1YR SUBSCRIPTIOIN	R	4/09/2019		233.94CR	112671	233.94
5504	RASMUSSEN, EMILIROSE							
	I-201904083364	LIBRARYTECHNOLOGY ARCHIVE GRAN	R	4/09/2019		305.27CR	112672	305.27
5733	VAST BROADBAND							
	I-201904013335	SRVC03/26-04/25	R	4/09/2019		89.94CR	112673	89.94
5891	ONE OFFICE SOLUTION							
	I-18674140	SUPPLIES	R	4/09/2019		1.81CR	112674	
	I-1876798-0	GENSUPPLIES	R	4/09/2019		32.10CR	112674	
	I-1880020-0	BALATON RECYCL	R	4/09/2019		18.86CR	112674	52.77
6072	LUND, CHELSEA							
	I-MLCL18	ANNUALREPORT/LYONCOLOGO	R	4/09/2019		485.00CR	112675	485.00
6246	MARSHALL MUNICIPAL UTILITIES **							
	I-201904083362	SRVC02/27-03/28	R	4/09/2019		3,060.08CR	112676	3,060.08
6299	IZQUIERDO, CHRISTINA							
	I-201904083357	LYND/GHENT DAYCARES	R	4/09/2019		16.24CR	112677	
	I-201904083358	COTTONWOOD/GHENT/MINNEOTA	R	4/09/2019		41.18CR	112677	
	I-201904083359	MINNEOTA/COTTONWOOD	R	4/09/2019		34.80CR	112677	92.22

VENDOR	NAME / I.D.	DESC	CHECK TYPE	CHECK DATE	DISCOUNT	AMOUNT	CHECK NO#	CHECK AMOUNT
* * T O T A L S * *								
				NO#	DISCOUNTS	CHECK AMT	TOTAL APPLIED	
		REGULAR CHECKS:		24	0.00	11,537.66	11,537.66	
		HANDWRITTEN CHECKS:		0	0.00	0.00	0.00	
		PRE-WRITE CHECKS:		0	0.00	0.00	0.00	
		DRAFTS:		0	0.00	0.00	0.00	
		VOID CHECKS:		1	0.00	0.00	0.00	
		NON CHECKS:		0	0.00	0.00	0.00	
		CORRECTIONS:		0	0.00	0.00	0.00	
		REGISTER TOTALS:		25	0.00	11,537.66	11,537.66	
TOTAL ERRORS: 0		TOTAL WARNINGS: 0						

VENDOR	NAME / I.D.	DESC	CHECK TYPE	CHECK DATE	DISCOUNT	AMOUNT	CHECK NO#	CHECK AMOUNT
--------	-------------	------	---------------	---------------	----------	--------	--------------	-----------------

** POSTING PERIOD RECAP **

FUND	PERIOD	AMOUNT
211	4/2019	11,537.66CR
=====		
ALL		11,537.66CR

**MINUTES OF THE
MARSHALL PLANNING COMMISSION MEETING
APRIL 10, 2019**

MEMBERS PRESENT: Fox, Ruud, Knieff, Steen, Edblom, Lee and Carstens

MEMBERS ABSENT: Ilya Gutman, Jason Anderson and Glenn Bayerkohler

OTHERS PRESENT:

1. The meeting was called to order by Chairman Edblom. He asked for the approval of the minutes of the March 28, 2019, special meeting of the Marshall Planning Commission. Steen MADE A MOTION, SECOND BY Fox, to approve the minutes as written. ALL VOTED IN FAVOR OF THE MOTION.
2. Gutman said this is a request by James Carr, Marshall, MN to rezone properties at 701, 703, 705, 800, 801, 802, 803, 804, 805, 806, 807, 900, 901, 902, 903, 904 and 905 Andrew Street from R-1 One Family Residential District to R-2 One to Four Family Residential District. To permit construction of tri-plex structures, as the owner desires, they must be rezoned to an R-2 One to Four Family Residential District. The adjacent land south of the zoning area is zoned R-2 One to Four Family Residential District. Staff recommends a motion to recommend approval to the City Council of the request to rezone 701, 703, 705, 800, 801, 802, 803, 804, 805, 806, 807, 900, 901, 902, 903, 904 and 905 Andrew Street from R-1 One Family Residential District to R-2 One to Four Family Residential District. Mike Schmidt, 703 Elaine Avenue, said that it appears that lots along Donald Street are all zoned R-2 One to Four Family and that is not developed so why do we want to rezone others. Carr said it is the progression of building in that direction. Schmidt said when the apartment complex was built on 4th Street, it was said at that time that the rest of this area would all be single family dwellings and that was assured. Carr said he did not own the land at that time. Schmidt said that doesn't make a difference; that is what was said that it would all be single family and now it is going to change. Carr said things change. Marshall used to be a working-class community and now Marshall is pushing business away and refuses to help businesses. Schmidt asked if building multifamily dwellings along that street will help that? Carr said people are aging in place. They want to buy a condo, get the snow removal done, the lawn work done, and right now Marshall has very few of these. If you want to see what is planned, go down Windstar Street; they have a couple of them there. Schmidt asked if they will be exactly like the white buildings. Fox said no, they are tan on the 900 block of Windstar. It would be like the tri-plex that is being built now. Carr said that he would take two lots and put a tri-plex in there. So, on one side where you have 7 single family lots, there might be 10 houses instead of 7 houses. Schmidt asked if Carr wants both sides of Andrew rezoned. Carr confirmed yes. Greg Labat, 705 Elaine Avenue, asked about parking on the street. He said in the winter time it is terrible over there. You get a car that is plowed around, and it sits there for a day or a day and half and there is only one lane traffic. Fox said it shouldn't be an issue; the tri-plex's will all have double car garage with driveway. Schmidt asked about a park in this area. At the time the apartment was going in, they said this would be a park. Fox said he doesn't know anything about that. Anderson said there is no park planned for that area at this point and time. Schmidt said the park was supposed to go in the Southwest corner. Anderson said that wasn't in the final plat. Gutman said it is in the comprehensive plan, but it is shown where it is already R-2 so it is not where we are rezoning. Anderson said there is no park in this development and there is not one scheduled to be in there currently. Susan Krenz, 1300 Cheryl Avenue, said that it seems to her there is a market for single family homes and there is a need in town. So, if these are already slotted to be single family, why not leave it. The other area is already

--UNAPPROVED --

zoned for R-2 so leave it the way it is, and one can still put tri-plex's just a little farther out. Anderson clarified that it is zoned R-1 but in an R-1 one can build up to a duplex in its current state; one can build a single family and up to a duplex and in an R-2 one can build a single family and up to a four-plex. Krenz said the letter said single family. Anderson said the duplex is by conditional use. Gutman said that is correct: you would have to have a Conditional Use Permit to have a duplex, but it is possible. Carr said you could have two units per lot so in 2 lots you could have four units. We are taking two lots and making 3 units. Schmidt asked what that means by conditional use. Anderson explained the process to obtain a Conditional Use Permit. Schmidt said it means you wouldn't be able to buy one of those lots and put up a duplex without getting permission. Anderson said that is correct. Schmidt asked if these units will be income based. Carr said no. Fox said these will be too high end for income based. He said the approximate cost is \$265,000 to \$275,000 per unit so they are upper end. Marie Sample, 1302 Cheryl Avenue, said we have 2 lots out there at the corner lot and the one behind us and when our neighbors moved out they were selling in the price range \$275,000 to \$300,000 or a little over; they are hard to find here in Marshall, so they looked at the house and they bought it. It was not on the market very long so why can't we keep those as single-family homes along Andrew Street; they are filling up rather quickly. There is a need for that in town, so we should maintain that at least for that block. Fox said there is a stronger demand right now for these tri-plex units. Sample said as soon as new houses go up on Elizabeth Street, they are sold just that fast. Anderson said that is important but we, as the Planning Commission and the City, are here to consider and evaluate whether it meets the City's Comprehensive Plan and good zoning practice. It is ultimately up to the private sector and developers to determine how they want to use the land within the zoning. Edblom said it is fair to say that over time the City has tried to work duplex and tri-plex in with single family development to make it work and you can look around the City and see that it does work. Krenz said she can see the point, but you already have a row lined up and you can leave Andrew as single family. Carr said that in talking to the realtor, they think it is easier to sell this plan. Schmidt asked if it is the sale of the units that is driving this. Fox said yes. Krenz said we should look at the good for the whole community that is there and not just the seller of the units. Carr said the good of the community is to put housing on the streets, and get the taxes the housing generates to better the City than to have nothing there. Krenz said these houses are being sold as quick as they are built too. Carr said they are not sold as easy as what people are saying they are. We build those spec houses when we sell them. Anyone can do it, but no one is doing it. Schmidt asked if this is the final say. Edblom advised it will go to the City Council for final decision. Carr said if your concerned about what they will look like, look at the ones on Windstar; it might ease the concerns. Edblom asked if the property on Windstar was Carr's. Carr confirmed yes. Lee MADE A MOTION, SECOND BY Steen, to close the public hearing. Fox abstained MOTION PASSED. Carstens said he lives at one of the 4 plex's on Windstar Street and it is a nice area. Carstens MADE A MOTION, SECOND BY Steen to recommend to City Council an approval as recommend by staff. Fox abstained. MOTION PASSED.

3. A MOTION WAS MADE BY Carstens, SECOND BY Lee to adjourn the meeting. ALL VOTED IN FAVOR. Chairman Edblom declared the meeting adjourned.

Respectfully submitted,
Chris DeVos, Recording Secretary

April 2019

Sun	Mon	Tue	Wed	Thu	Fri	Sat
	1	2 4:30 p.m. Airport Commission	3	4	5	6
7	8 3:30 p.m. Public Housing Commission 4:00 p.m. Library Board	9 5:30 p.m. Regular City Council Meeting	10 5:30 p.m. Planning Commission	11	12	13
14	15 5:30 PM Local Board of Appeal and Equalization	16 4:30 p.m. Marshall Municipal Utilities Commission	17 12:00 p.m. EDA	18 2:00 p.m. CVB Board Meeting	19	20
21	22	23 5:00 p.m. Local Board of Appeal and Equalization 5:30 p.m. Regular City Council Meeting	24	25	26	27
28	29	30				

May 2019

Sun	Mon	Tue	Wed	Thu	Fri	Sat
			1 4:45 p.m. Community Services Advisory Board	2	3	4
5	6	7 4:30 p.m. Airport Commission	8 5:30 p.m. Planning Commission	9	10	11
12	13 3:30 p.m. Public Housing Commission 4:00 p.m. Library Board	14 5:30 p.m. Regular City Council Meeting	15 12:00 p.m. EDA	16 2:00 p.m. CVB Board Meeting	17	18
19	20	21 4:30 p.m. Marshall Municipal Utilities Commission	22	23	24	25
26	27 City Hall Closed – Memorial Day	28 5:30 p.m. Regular City Council Meeting	29	30	31	

June 2019

Sun	Mon	Tue	Wed	Thu	Fri	Sat
						1
2	3	4 4:30 p.m. Airport Commission	5	6	7	8
9	10 3:30 p.m. Public Housing Commission 4:00 p.m. Library Board	11 5:30 p.m. Regular City Council Meeting	12 12:00 p.m. Adult Community Center 5:30 p.m. Planning Commission	13	14	15
16	17	18 4:30 p.m. Marshall Municipal Utilities Commission	19 12:00 p.m. EDA	20 2:00 p.m. CVB Board Meeting	21	22
23	24	25 5:30 p.m. Regular City Council Meeting	26	27	28	29
30						